



Test Plan for Wireless Device Over-the-Air Performance

CTIA 01.41 Test Methodology, MIMO, Static Channel
Model, Radiated Two Stage

Version 7.0.0

April 2024

© 2001 - 2024 CTIA Certification. All Rights Reserved.

Any reproduction, modification, alteration, creation of a derivative work, or transmission of all or any part of this publication ("Test Plan"), in any form, by any means, whether electronic or mechanical, including photocopying, recording, or via any information storage and retrieval system, without the prior written permission of CTIA Certification, is unauthorized and strictly prohibited by federal copyright law. This Test Plan is solely for use within the CTIA Certification Program. Any other use of this Test Plan is strictly prohibited unless authorized by CTIA Certification or its assigns in writing.

Use Instructions

All testing shall be performed in a CTIA Certification Authorized Test Lab and shall be initiated through one of the following methods:

1. By submitting a PTCRB or IoT Network Certified device certification request at <https://certify.ptcrb.com/>
2. By submitting an OTA Test Plan use request at <https://certify.ctiacertification.org/>

CTIA Certification LLC
1400 16th Street, NW
Suite 600
Washington, DC 20036

1.202.785.0081

programs@ctiacertification.org

ctiacertification.org/test-plans/

Table of Contents

| | | |
|-----------|--|----|
| Section 1 | Introduction | 6 |
| 1.1 | Purpose | 6 |
| 1.2 | Scope..... | 6 |
| 1.3 | MIMO OTA Test Overview | 6 |
| 1.4 | Over-the-Air Test System | 6 |
| 1.4.1 | Radiated Two Stage (RTS) | 6 |
| 1.5 | Acronyms and Definitions | 8 |
| 1.6 | Referenced Documents | 10 |
| Section 2 | MIMO Receiver Performance Assessment (Open-Loop Spatial Multiplexing)..... | 11 |
| 2.1 | RTS General Description..... | 11 |
| 2.2 | RTS System Setup | 11 |
| 2.2.1 | RTS Ripple Test | 11 |
| 2.2.2 | RTS Calibration | 11 |
| 2.2.2.1 | Input Calibration for RTS utilizing external channel emulator with analog RF interface | 11 |
| 2.2.2.2 | Output Calibration for RTS utilizing external channel emulator with analog RF interface . | 12 |
| 2.2.2.3 | Channel Emulator Input Phase Calibration for RTS utilizing external channel emulator with analog RF interface..... | 12 |
| 2.3 | DUT Positioning within the RTS Test Volume | 12 |
| 2.3.1 | SIR Validation within the RTS Test Zone | 12 |
| 2.4 | MIMO OTA Test Methodology | 13 |
| 2.4.1 | SIR-Controlled Test Procedure Using the RTS..... | 13 |
| 2.4.2 | Applicability of RTS..... | 15 |
| Section 3 | Receiver Performance Uncertainties..... | 16 |
| 3.1 | Summary of Common Uncertainty Contributions for MIMO Receiver Performance | 16 |
| 3.2 | Combined and Expanded Uncertainties for Overall MIMO Receiver Performance | 17 |
| 3.2.1 | Compliance Criteria for the Overall MIMO Receiver Performance Uncertainty for RTS.... | 17 |
| Section 4 | Validation and Verification of Test Environments and Test Conditions (Normative)..... | 18 |
| 4.1 | Measurement Instrument Overview..... | 18 |
| 4.1.1 | Measurement Instruments and Setup | 18 |
| 4.1.2 | Setup with Internal Channel Emulator | 18 |
| 4.1.3 | Spectrum Analyzer (SA) Setup with External Channel Emulator | 19 |
| 4.2 | Validation of the RTS MIMO OTA Test Environment and Test Conditions..... | 19 |
| 4.2.1 | Validation of SIR-Controlled RTS Test Environment..... | 19 |
| 4.2.1.1 | Validation of RTS Power Delay Profile (PDP) | 19 |
| 4.2.1.2 | Power Delay Profile Result Analysis | 20 |
| 4.2.1.3 | Measurement Antenna | 20 |
| 4.2.1.4 | Pass/Fail Criteria | 21 |
| 4.2.2 | Validation of Doppler/Temporal Correlation for RTS..... | 21 |
| 4.2.2.1 | RTS Doppler/Temporal Correlation Method of Measurement..... | 21 |

| | | |
|------------|--|----|
| 4.2.2.2 | RTS Doppler/Temporal Correlation Measurement Antenna | 22 |
| 4.2.3 | Validation of RTS Spatial Correlation | 22 |
| 4.2.3.1 | RTS Spatial Correlation Method of Measurement..... | 22 |
| 4.2.3.2 | RTS Spatial Correlation Measurement Results Analysis | 24 |
| 4.2.3.3 | RTS Spatial Correlation Measurement Antenna | 24 |
| 4.2.4 | Validation of Cross-Polarization for RTS | 25 |
| 4.2.4.1 | RTS Cross Polarization Method of Measurement | 25 |
| 4.2.4.2 | RTS Cross Polarization Measurement Procedure | 25 |
| 4.2.4.3 | Cross Polarization Expected Measurement Results | 26 |
| 4.2.5 | Input Phase Calibration Validation (Normative) | 26 |
| Section 5 | Variable RMC MIMO Throughput Test (Informative)..... | 27 |
| Appendix A | Revision History | 28 |

List of Figures

| | |
|--|----|
| Figure 1.4.1-1 Block Diagram of an Example Radiated Two-Stage RF Environment Simulation System .. | 8 |
| Figure 2.3.1-1 Typical Setup for Verifying SIR Level in the Anechoic Chamber Multi-Probe MIMO OTA Test System..... | 13 |
| Figure 4.1.2-1 Setup for RTS With Internal Channel Emulator..... | 19 |
| Figure 4.1.3-1 Setup for Spectrum Analyzer Measurements with External Channel Emulator | 19 |
| Figure 4.2.3.1-1 RX Antenna Position Configurations | 23 |

List of Tables

| | |
|--|----|
| Table 3.1-1 Common Uncertainty Contributions for MIMO DUT Receiver Performance Measurement | 16 |
| Table 3.2.1-1 Expanded Uncertainty Maximum Limit for MIMO Receiver Performance for the RTS Methodology | 17 |
| Table 4.1.1-1 Required Measurement Equipment..... | 18 |
| Table 4.2.1.1-1 RTS PDP Measurement Parameter Settings | 20 |
| Table 4.2.1.1-2 RTS PDP Channel Model Specification | 20 |
| Table 4.2.2.1-1 RTS Doppler/Temporal Correlation Signal Generator Settings..... | 21 |
| Table 4.2.2.1-2 RTS Doppler/Temporal Correlation Spectrum Analyzer Settings | 21 |
| Table 4.2.2.1-3 Doppler Channel Model Specification | 22 |
| Table 4.2.3.1-1 RTS Spatial Correlation Settings | 23 |
| Table 4.2.3.1-2 RTS Spatial Correlation Channel Model Specification | 23 |
| Table 4.2.3.2-1 RTS Reference Spatial Correlation Function for SCME Urban Macro..... | 24 |
| Table 4.2-9 RTS Cross-Polarization Spectrum Analyzer Settings..... | 25 |
| Table 4.2-10 RTS Cross-Polarization Channel Model Specification | 25 |

Section 1 Introduction

1.1 Purpose

The purpose of this document is to define the CTIA Certification program test methodology for radiated performance measurements of LTE 2x2 downlink MIMO wireless devices. Future revisions of this test plan may also include methodologies for assessing radiated performance during non-MIMO operation using transmit diversity.

1.2 Scope

This test plan defines general requirements for test systems, test conditions, equipment configurations, laboratory techniques, test methodologies, and evaluation criteria that must be met in order to ensure the accurate, repeatable, and uniform testing of wireless devices capable of supporting LTE 2x2 downlink MIMO. Future revisions of this document may include the equipment configurations, test methodologies, and evaluation criteria required to assess the DUT's transmit diversity performance.

This test plan provides high level test procedures and basic test equipment configuration information but does not include detailed test instructions by which to execute certification testing. Such documentation and procedures must be presented by the CTIA Certification Authorized Test Lab (ATL) as part of the CTIA authorization process and subsequently employed and maintained by the ATL to remain authorized to perform certification testing.

1.3 MIMO OTA Test Overview

The scope and overview of the MIMO OTA Test Plan is outlined in Section 1.3 and specifically in Section 1.3.3 of *CTIA 01.01* [1].

1.4 Over-the-Air Test System

The tests described in this document require a test system capable of emulating reproducible multi-path over-the-air propagation channels meeting all specifications of the required spatial channel models. In this test plan, the test system currently specified is capable of producing the required test conditions for all of the required test cases listed in the following sections, with certain limitations associated with the UE antenna spacing as described in Section 2.2.2. Calibration and validation methodologies are provided as well.

1.4.1 Radiated Two Stage (RTS)

The basic concept of the Radiated Two-Stage MIMO OTA method is to divide the OTA test into two stages: The first stage is to acquire the DUT's complex antenna pattern, the second stage is to do perform the throughput measurements using a downlink signal generated by convolving the antenna pattern with the desired spatial channel model and then transmitting it through a radiated connection. The resulting test signal generated by the channel emulator and coupled back into the DUT receivers represents the signal that the DUT receivers would have seen if the DUT had been placed in the desired environment. Thus, an ideal implementation of the radiated two-stage method provides the same results as an ideal implementation of the boundary antenna array method.

In order to accurately measure the antenna pattern of the uncompromised device in the first stage, the DUT chipset needs to support received amplitude and the phase difference between each receiver branch. These two UE measurements are part of the Antenna Test Function (ATF) and are commonly referred to as Reference Signal Antenna Power (RSAP) and Reference Signal Antenna Relative Phase

(RSARP). These measurements are defined in *3GPP TS 36.509* [2]. The validity of antenna pattern measurement is predicated on the assumption that for the frequency being tested, the DUT antenna pattern is static. Devices that can alter their antenna pattern in real time as a function of the radiated environment – sometimes referred to as active antennas – are currently not applicable as noted in [Section 2.4.2](#). The method of coupling the base station and channel emulator to the DUT is done using a specially calibrated radiated connection and fully captures radiated desensitization.

In the second stage, the desired antenna pattern is loaded into a channel emulator and convolved with the spatial channel model being used to evaluate the DUT performance. The generated downlink signal can be fed into the DUT receiver by using a radiated connection. The radiated connection method used in RTS is achieved by transmitting the wanted test signals over the air in the anechoic chamber. To create the desired situation where one stream is received only by one DUT receiver and the other stream is received only by the other DUT receiver, it is necessary to determine the transmission properties between the test system's downlink antenna and the input of the DUT's receiver. This transmission matrix, commonly referred to as channel matrix, is then inverted and applied in the channel emulator which emulates a conducted test in the radiated environment. The establishment of the radiated connection is explained as follows: Assume x_1 and x_2 are the transmitted signals from the base station emulator, after applying the desired channel model and convolution with the complex antenna pattern we get $f(x_1)$ and $f(x_2)$.

The radiated channel matrix between the probe antennas and the DUT antennas is $\begin{pmatrix} h_{11} & h_{12} \\ h_{21} & h_{22} \end{pmatrix}$.

If the channel emulator applies the inverse of the radiated channel matrix $H^{-1} = \begin{pmatrix} \alpha & \beta \\ \gamma & \delta \end{pmatrix}$ to $f(x_1)$ and $f(x_2)$, the signal received after the DUT antennas is the same as a conducted test while taking desense effects into account:

$$\begin{pmatrix} y_1 \\ y_2 \end{pmatrix} = \begin{pmatrix} h_{11} & h_{12} \\ h_{21} & h_{22} \end{pmatrix} \begin{pmatrix} \alpha & \beta \\ \gamma & \delta \end{pmatrix} \begin{pmatrix} f(x_1) \\ f(x_2) \end{pmatrix} = \begin{pmatrix} 1 & 0 \\ 0 & 1 \end{pmatrix} \begin{pmatrix} f(x_1) \\ f(x_2) \end{pmatrix} = \begin{pmatrix} f(x_1) \\ f(x_2) \end{pmatrix}$$

Due to test system and measurement limitations, a finite isolation between streams can be observed. Generally, 15dB of isolation were found to be sufficient with negligible impact in throughput. The isolation that can be achieved is optimized by using orthogonal polarizations from the same probe antenna or two polarizations from two separate antennas careful selection of the DUT orientation in the second stage. Once the channel has been isolated, the DUT's position/orientation is fixed throughout the measurements in the 2nd stage and the device orientations as defined in Section 3 of *CTIA 01.71* [6] are emulated by rotating the antenna patterns in the channel emulator.

The RTS method is illustrated in [Figure 1.4.1-1](#). The minimum requirement for the RTS system is the use of a SISO OTA chamber with a single dual-polarized probe. Alternatively, as shown in [Figure 1.4.1-1](#), two probe antennas can be used which would also allow a potential extension to 4x4 MIMO.

The channel emulator used for RTS could be internal (integrated within the base station emulator) or external (connected to the base station emulator via digital I/Q or analog RF interface).

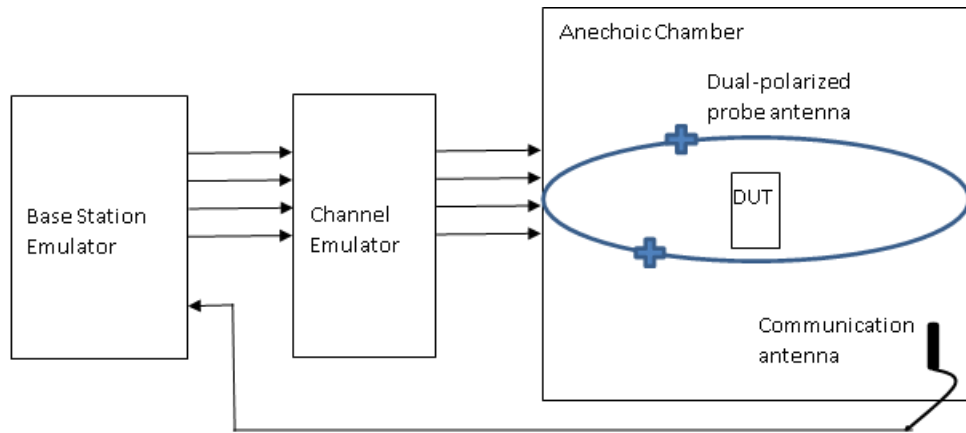

Figure 1.4.1-1 Block Diagram of an Example Radiated Two-Stage RF Environment Simulation System

1.5 Acronyms and Definitions

The following specialized terms and acronyms are used throughout this document.

| Acronym/Term | Definition |
|--------------------|--|
| AS | Angular Spread |
| ATF | Antenna Test Function |
| ATL | Authorized Test Lab |
| BS | Base Station |
| CIR | Channel Impulse Response |
| DML | Data Mode-Landscape |
| DMP | Data Mode-Portrait |
| DMSU | Data Mode Screen Up |
| DUT | Device Under Test |
| FS | Free Space |
| FDD | Frequency Division Duplexing |
| IFFT | Inverse Fast Fourier transform |
| MARSS | MIMO Average Radiated SIR Sensitivity |
| MIMO | Multiple Input Multiple Output |
| Measurement Points | The individual data points collected during execution of the requisite test methodology. |

| Acronym/Term | Definition |
|-------------------------|--|
| MPAC | Multi-Probe Anechoic Chamber, utilized for the assessment of MIMO-capable devices. |
| PDSCH-EPRE | Packet Downlink Shared Channel-Energy Per Resource Element |
| PDP | Power Delay Profile |
| RSAP | Reference Signal Antenna Power |
| RSARP | Reference Signal Antenna Relative Phase |
| RS-EPRE | Reference Signal-Energy Per Resource Element |
| RTS | Radiated Two Stage |
| RX | Receive |
| SA | Spectrum Analyzer |
| SCME | Spatial Channel Model Extension |
| SIR | Signal to Interference Ratio |
| Test Condition | The emulated propagation conditions utilized within the test system. In this version of this test specification, the SCME UMa channel model is the only valid test condition. The test condition is only seen in the validated test volume of the test system. |
| Test System | The controlled propagation environment used for evaluation of the DUT. In the context of this version of this test plan, the Multi Probe Anechoic Chamber (MPAC) and Radiated Two-Stage are the only valid test systems. |
| Test Methodology | The process used to execute tests against the DUT using the Test System(s) and Test Condition(s) specified by this document. |
| Test Volume | The useable volume within the test system in which the DUT can be placed. The test volume is assumed to have a uniform power distribution within the uncertainty specified by the site validation. |
| Test Zone | The portion of the test volume in which the test condition criteria are met within the applicable uncertainty limits. |
| TDD | Time Division Duplexing |
| UMa | Urban Macro |

1.6 Referenced Documents

The following documents are referenced in this document:

| | |
|------|---|
| [1] | CTIA 01.01, <i>Test Scope, Requirements, and Applicability</i> |
| [2] | 3GPP TS 36.509, <i>Evolved Universal Terrestrial Radio Access (E-UTRA) and Evolved Packet Core (EPC); Special conformance testing functions for User Equipment (UE)</i> |
| [3] | CTIA 01.73, <i>Ancillary Procedures</i> |
| [4] | 3GPP TS 36.508, <i>Evolved Universal Terrestrial Radio Access (E-UTRA) and Evolved Packet Core (EPC); Common test environments for User Equipment (UE) conformance testing</i> |
| [5] | CTIA 01.40, <i>Test Methodology MIMO Multi-Probe Anechoic Chamber</i> |
| [6] | CTIA 01.71, <i>Positioning Guidelines</i> |
| [7] | 3GPP TS 36.521-1, <i>Evolved Universal Terrestrial Radio Access (E-UTRA); User Equipment (UE) conformance specification; Radio transmission and reception; Part 1: Conformance testing</i> |
| [8] | CTIA 01.03, <i>Normative Reporting Tables</i> |
| [9] | CTIA 01.70, <i>Measurement Uncertainty</i> |
| [10] | 3GPP TS 36.213, <i>Evolved Universal Terrestrial Radio Access (E-UTRA); Physical layer procedures</i> |
| [11] | 3GPP TR 37.977, <i>Universal Terrestrial Radio Access (UTRA) and Evolved Universal Terrestrial Radio Access (E-UTRA); Verification of radiated multi-antenna reception performance of User Equipment (UE)</i> |
| [12] | 3GPP TR 37.901, <i>User Equipment (UE) application layer data throughput performance</i> |
| [13] | CTIA 01.72, <i>Near-Field Phantoms</i> |
| [14] | CTIA 01.20, <i>Test Methodology, SISO, Anechoic Chamber.</i> |

Section 2 MIMO Receiver Performance Assessment (Open-Loop Spatial Multiplexing)

2.1 RTS General Description

The tests in this section assess the DUT's MIMO OTA throughput performance when the serving eNodeB is utilizing Open-Loop Spatial Multiplexing (OL-SM). During execution of OL-SM tests, the DUT shall be illuminated with an average RS-EPRE that is maintained constant while the on-channel AWGN interferer is varied. All OL-SM tests shall be executed in the RTS where the spatial and temporal characteristics of the SCME channel may be emulated and controlled.

2.2 RTS System Setup

This test procedure currently assumes the use of an RTS test system for generation of the desired test conditions. In addition to qualifying the implementation of the channel model to be used as specified in [Section 4.2](#) each system installation shall be calibrated and validated to ensure proper operation.

2.2.1 RTS Ripple Test

For the RTS methodology, the standard phi-axis and theta-axis ripple tests described in Section 5 of *CTIA 01.73* [3] shall be used. The Notebook PC sized test volume is not required to be measured. The tests shall be performed at the frequencies outlined in Section 3 of *CTIA 01.73* [3].

2.2.2 RTS Calibration

Calibration of the RTS system is the same as the range reference measurement described in Section 4 of *CTIA 01.73* [3].

For the purposes of calibration of an external channel emulator, it can be thought of as a variable gain stage (e.g., variable attenuator) with level adjustments at both inputs and outputs as well as an internal loss component associated with the chosen channel model. The ability to selectively enable specific inputs and outputs allow it to be used as a splitter/switch combination to enable specific signal paths for calibration.

While traditional sensitivity measurements like those used in TIS testing only require one absolute power reference at the communication tester, the addition of Signal to Interference Ratio (SIR) based testing requires a second power reference at the interferer source. A typical approach for introducing interference is to inject the noise at each output of the channel emulator, thus requiring the determination of the difference in path losses between the communication tester output and channel emulator output, in addition to the net path loss from the communication tester to the center of the test volume. For systems utilizing completely independent noise sources, the path loss from that noise source to the center of the test volume must be determined independently.

The test frequencies to be used when calibrating the RTS system shall correspond to the frequency of the downlink for mid-range from *3GPP TS 36.508* [4] as required per band for the normative bands defined in Table 2.3 1 and Table 2.3 2 of *CTIA 01.40* [5].

2.2.2.1 Input Calibration for RTS utilizing external channel emulator with analog RF interface

For RTS systems utilizing internal channel emulators or external channel emulators using baseband I/Q interface, this input calibration is not applicable. RTS implementations utilizing external channel emulator with an analog RF interface shall follow the procedures outlined in Section 2.2.2.1 of *CTIA 01.40* [5].

2.2.2.2 Output Calibration for RTS utilizing external channel emulator with analog RF interface

For RTS systems utilizing internal channel emulators or external channel emulators using baseband I/Q interface, this output calibration is not applicable.

RTS implementations utilizing external channel emulator with an analog RF interface shall follow the procedures outlined in Section 2.2.2.2 of *CTIA 01.40* [5].

2.2.2.3 Channel Emulator Input Phase Calibration for RTS utilizing external channel emulator with analog RF interface

Unlike the MPAC boundary array approach, the RTS methodology does not require the input phase calibration as phase differences are calibrated out during the isolation stage. However, the combination of base station emulator and channel emulator needs to guarantee phase stability as the isolation will otherwise deteriorate.

2.3 DUT Positioning within the RTS Test Volume

In order to minimize measurement uncertainty, it's important that ATLS ensure the DUT is oriented within the chamber's test zone in a standardized manner. Section 3.4 of *CTIA 01.71* [6] provides a preliminary set of normative DUT orientation conditions and the informative DUT orientation conditions are found in Section 3.5 of *CTIA 01.71* [6]. MIMO Average Radiated SIR Sensitivity (MARSS)

Section 2.4 of *CTIA 01.40* [5] applies except when superseded by the following subsections.

2.3.1 SIR Validation within the RTS Test Zone

The interference level necessary to achieve a given SIR inside the test zone shall be generated as an independent process at each antenna probe with equal power, regardless of the signal power transmitted through that probe. The SIR is defined at resource element level as per *3GPP TS 36.521-1* [7] clause 8.1.1. [Figure 2.3.1-1](#) illustrates a typical configuration for measuring the power levels within the test volume. This may be used to determine the net power produced after balancing the output paths and in validating the SIR generated by the system.

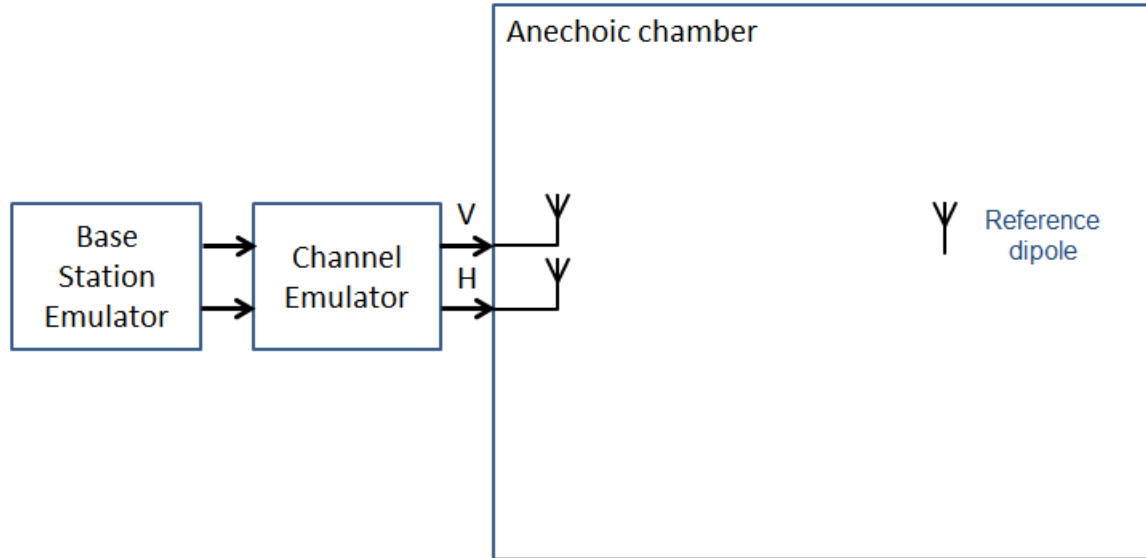

Figure 2.3.1-1 Typical Setup for Verifying SIR Level in the Anechoic Chamber Multi-Probe MIMO OTA Test System

The power and SIR validation shall be performed to ensure that all of the system corrections have been applied properly. Since the test essentially measures the residual error term in the system, and any measured error should be corrected for, the validation process may also be used as a final path loss correction. While the power validation process has a measurement uncertainty of its own, defined primarily by the reference antenna gain uncertainty, the cable loss correction uncertainty, and the receiver uncertainty, this may be smaller than the net uncertainty of the signal source components and path loss corrections applied. The results of the power and SIR validation may be used to correct for system-level offset(s) to further reduce measurement uncertainty if the validation uncertainty is less than the path loss measurement uncertainty. Note however that especially when determining the SIR, the interference level can easily be biased by the noise floor of the instrumentation. Care should be taken not to introduce invalid offsets due to noise in the validation test.

2.4 MIMO OTA Test Methodology

Section 2.5 of *CTIA 01.40* [5] applies except when superseded by the following subsections.

2.4.1 SIR-Controlled Test Procedure Using the RTS

The following pre-tests and pre-conditions need to be met before performing an OL-SM SIR-controlled test using the RTS, position the DUT within the test zone according to Section 2.3.1 with the azimuth positioner at zero degrees.

1. Measure the DUT RX complex antenna pattern at a nominal -60 dBm downlink power as described in Section 1.4.1 (first stage).
2. Select an appropriate orientation from the measured antenna pattern and establish a radiated MIMO connection to the DUT using the V and H probes as described in Section 1.4.1 (second stage). Measure the transmission matrix in the chamber and apply the

- inverse matrix to the MIMO signal. The DUT orientation at which this is done is selected to optimize the achievable isolation.
3. With the desired channel model applied, measure the isolation in dB between each stream as seen by the DUT receiver and ensure it is at least 15 dB averaged over at least 200 RSAP measurements.
 4. Using the calibrated radiated connection validate monotonicity of the DUT RSAP and RSARP measurements over the range -60 dB, to -80 dBm and +/- 180 degrees. The step size for RSAP shall be 1 dB and the step size for RSARP shall be 5 degrees.
 5. Once monotonicity has been validated, check the linearity of RSAP at the orientation of the peak antenna gain over the range -60 dBm to -80 dBm is < 1 dB. Check the linearity of RSARP is within 5 degrees over the range +/- 180 degrees. If the uncorrected RSAP or RSARP results do not meet the linearity requirements, calculate and apply a transfer function to the measured patterns to ensure the necessary linearity.
 6. Convolve the antenna patterns from stage 1 with the channel model in the channel emulator and perform the throughput test.

Note: In this test plan, SIR refers to the SIR illuminating the DUT in the test volume, as opposed to the SIR seen by the DUT's receiver.

Establish a connection to the DUT with the specified SCME UMa channel model and an SIR setting of 30 dB. Beginning with the initial orientation of the DUT at 0 degrees azimuth within the channel emulator, determine the SIR values associated with the 95%, 90%, and 70% outage levels based on the theoretical throughput rate using the specified minimum number of subframes and the maximum theoretical throughput called for in Table 2.4-1 of *CTIA 01.40* [5] (for FDD devices) or Table 2.4-2 of *CTIA 01.40* [5] (for TDD devices).

Note: Ensure that the transmitted power available from the DUT is sufficient to support error-free operation on the uplink. To ensure that any impact due to the DUT uplink power and/or the downlink omni-directional interferer is minimal, the percentage of DTX subframes over the measurement period shall be less than 0.25%.

When performing this measurement, the desired SIR result may be determined by interpolating to an SIR level between two throughput points measured within 0.5 dB of each other, or by reporting the last passing (higher) measured throughput point within 0.5 dB of the target. Algorithms that use fewer subframes and/or larger step sizes are acceptable provided the final reported data for each level is based on the result of two throughput measurements within 0.5 dB of each other and with the specified number of subframes. Due to the nature of the faded signal, early exit statistical measurement techniques are not allowed. Repeat the SIR sensitivity measurement described above every 30 degrees in azimuth, rotating the DUT clockwise, for a total of twelve positions. The SIR associated with each throughput outage point and azimuthal orientation shall be documented in Table RC.2-1 of *CTIA 01.03* [8].

If the DUT is unable to reach the throughput point(s) defined in Section 2.5.2 of *CTIA 01.40* [5] at an SIR of 30 dB, the lab shall document one of the following in Table RC.2-1 of *CTIA 01.03* [8] for each azimuthal orientation where the DUT failed to meet the target throughput:

- An SIR value of 30 dB, or
- The linear average of the remaining SIR values where the DUT was able to reach the throughput point(s), plus 10 dB

The SIR substitution value employed for failing azimuthal orientations shall be the maximum SIR obtained from the two options above.

2.4.2 Applicability of RTS

The applicability criteria of the RTS method are:

- The RTS method requires device support for the antenna test function (ATF)
- The RTS method is only applicable to devices which do not change their antenna pattern or configuration in response to the radio environment.
- The RTS method can only be used if the isolation between channels is above 15dB.

Section 3 Receiver Performance Uncertainties

3.1 Summary of Common Uncertainty Contributions for MIMO Receiver Performance

Table 3.1-1 lists common uncertainty contributions for the MIMO DUT receiver performance measurement defined in this test plan.

Table 3.1-1 Common Uncertainty Contributions for MIMO DUT Receiver Performance Measurement

| No | Uncertainty Contribution | Reference | Comment |
|-----|---|-------------------------------------|---|
| 1. | Range Loss Measurement(s) | See Table 3.2 1 of CTIA 01.40 [5] | Net path loss measurement MU from signal reference to DUT. |
| 2. | Mismatch: communication tester | See Section 2.1 of CTIA 01.70 [9] | Final system side mismatch between instrumentation and system. |
| 3. | Signal Source Absolute Power Reference or Stability: communication tester | See Section 2.5 of CTIA 01.70 [9] | Depends on SIR Implementation |
| 4. | Receiver Stability: Channel Emulator | See Section 2.4 of CTIA 01.70 [9] | |
| 5. | Signal Source Linearity: Channel Emulator | See Section 2.5 of CTIA 01.70 [9] | Applies for variable power control. |
| 6. | Signal Source Stability: Channel Emulator | See Section 2.5 of CTIA 01.70 [9] | Applies for variable interference control. |
| 7. | Signal Source Absolute Power Reference or Linearity and Relative Error: AWGN Source | See Section 2.5 of CTIA 01.70 [9] | Contribution type depends on whether AWGN source is a separate generator or part of existing test equipment. |
| 8. | Range Loss Measurement(s): AWGN Source | See Section 2.5 of CTIA 01.70 [9] | Applies to the associated portion of the path if a separate AWGN source with all or partially separate path to test volume is used. |
| 9. | Mismatch: AWGN Generator(s) | See Section 2.1 of CTIA 01.70 [9] | Final system side mismatch between instrumentation and system. Applies if separate AWGN generator is used, requiring a separate calibration path. |
| 10. | Measurement Antenna Cable Factor | See Section 2.2 of CTIA 01.70 [9] | |
| 11. | Blocking Effect of the DUT on the Measurement Antenna (if too close) | See Section 2.9.3 of CTIA 01.70 [9] | |
| 12. | Influence of the ambient temperature on the test equipment | See Section 2.12 of CTIA 01.70 [9] | |
| 13. | Miscellaneous uncertainty | See Section 2.22 of CTIA 01.70 [9] | |
| 14. | Minimum downlink/interference power step size uncertainty | See Section 2.20 of CTIA 01.70 [9] | |

| No | Uncertainty Contribution | Reference | Comment |
|-----|---|--------------------------------------|---------|
| 15. | Stability | See Section 2.7 of CTIA 01.70 [9] | |
| 16. | Linearity | See Section 2.7 of CTIA 01.70 [9] | |
| 17. | Amplifier Noise | See Section 2.7 of CTIA 01.70 [9] | |
| 18. | DUT Positioning Uncertainty Relative to Phantoms and Fixtures | See Section 2.13 of CTIA 01.70 [9] | |
| 19. | Measurement Setup Repeatability | See Section 2.19 of CTIA 01.70 [9] | |
| 20. | Effect of Ripple on DUT Measurements | See Section 2.10.2 of CTIA 01.70 [9] | |
| 21. | Test System Frequency Flatness Uncertainty | See Section 2.28 of CTIA 01.70 [9] | |
| 22. | Impact of ATF pattern error on TP | See Section 2.42 of CTIA 01.70 [9] | |
| 23. | Impact of non-ideal isolation between streams in radiated 2nd stage | See Section 2.43 of CTIA 01.70 [9] | |

3.2 Combined and Expanded Uncertainties for Overall MIMO Receiver Performance

After calculation the combined standard uncertainties in CTIA 01.70 [9], they should be combined as follows to derive the overall combined standard uncertainty:

Equation 3.2-1

$$u_c = \sqrt{u_c^2 \text{ contribution from the EUT measurement} + u_c^2 \text{ contribution from the reference measurement}}$$

Next, the expanded uncertainty, U , is calculated as outlined in Section 2 of CTIA 01.70 [9]. The resulting value for expanded uncertainty for MIMO receiver performance should be stated in the results sheet.

3.2.1 Compliance Criteria for the Overall MIMO Receiver Performance Uncertainty for RTS

Table 3.2.1-1 Expanded Uncertainty Maximum Limit for MIMO Receiver Performance for the RTS Methodology

| Test Configuration | Expanded Uncertainty Max Limit (dB) |
|--------------------|-------------------------------------|
| Free Space | 2.25 |

Section 4 Validation and Verification of Test Environments and Test Conditions (Normative)

This section describes the MIMO OTA validation measurements required to ensure that the test conditions are correctly implemented and hence capable of generating the propagation environment, as described by the model. Within the designated test zone, measurements are performed mainly with a spectrum analyzer and a BS emulator. Two suitable channel model validation setups are described further in this section depending on whether the internal channel emulator or external emulator are used. The system provider shall perform the validation tests at the frequency of the downlink for mid-range from *3GPP TS 36.508* [4] as required per band for the normative bands defined in Table 2.3-1 and Table 2.3-2 of *CTIA 01.40* [5].

4.1 Measurement Instrument Overview

4.1.1 Measurement Instruments and Setup

The measurement setup includes the following equipment:

Table 4.1.1-1 Required Measurement Equipment

| Item | Quantity | Item |
|------|----------|--|
| 1 | 1 | Channel Emulator |
| 2 | 1 | Signal Generator |
| 3 | 1 | Spectrum Analyzer |
| 4 | 1 | Dual-polarized antenna with at least 15dB polarization isolation |

4.1.2 Setup with Internal Channel Emulator

The simplest RTS system setup utilizes a BS emulator with internal channel emulators or external channel emulators using baseband I/Q interface. An example set of equipment required for this set-up is shown in [Figure 4.1.2 1](#). One dual-polarized antenna with at least 15 dB polarization isolation is installed in the center of the test zone to receive the signals. The received signals from test antenna can be captured by the BS emulator. This setup can be used to measure PDP, spatial correlation, Doppler spectrum/temporal correlation and polarization of the SCME UMa channel model defined in Section 2.4.3 of *CTIA 01.40* [5].

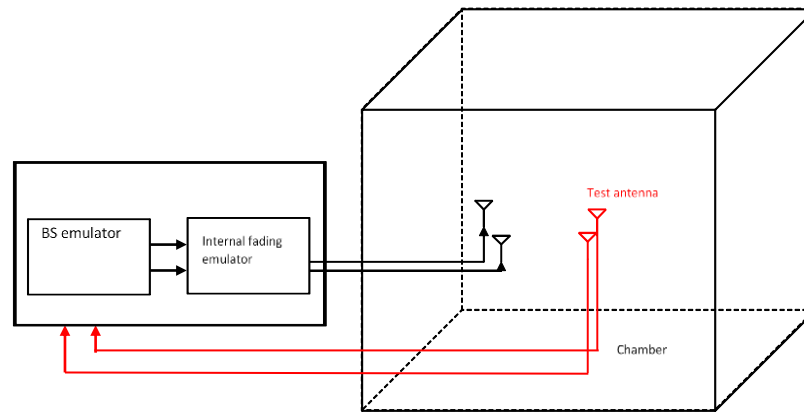

Figure 4.1.2-1 Setup for RTS With Internal Channel Emulator

4.1.3 Spectrum Analyzer (SA) Setup with External Channel Emulator

A spectrum analyzer setup with external channel emulator is shown in [Figure 4.1.3-1](#). In this case a signal generator transmits a CW signal through the test system. The signals are received by test antenna with two polarizations within the test area. Finally, the signals are captured by a spectrum analyzer with two ports and the SW can do the post processing on the captured signal to output analysis results. This setup can be used to measure PDP, spatial correlation, Doppler spectrum/temporal correlation and polarization of the SCME UMa channel model defined in Section 2.4.3 of *CTIA 01.40* [5].

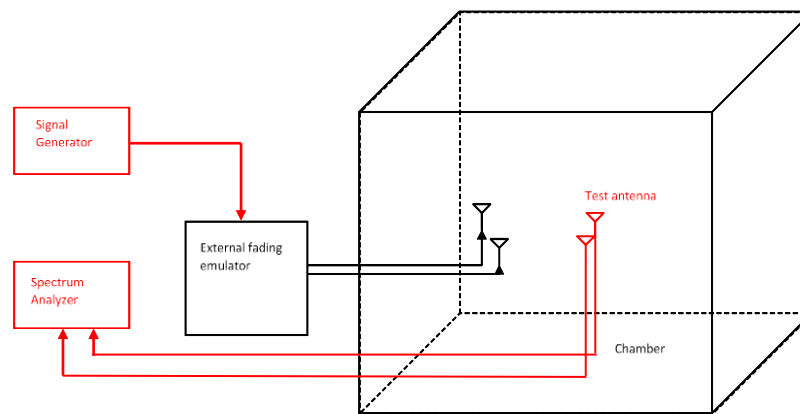

Figure 4.1.3-1 Setup for Spectrum Analyzer Measurements with External Channel Emulator

4.2 Validation of the RTS MIMO OTA Test Environment and Test Conditions

4.2.1 Validation of SIR-Controlled RTS Test Environment

4.2.1.1 Validation of RTS Power Delay Profile (PDP)

This measurement checks that the resulting power delay profile (PDP) is in-line with the PDP defined for the channel model using the setup in [Figure 4.1.2-1](#).

Method of measurement: configure BS emulator to send out the multi-tone signal, the multi-tone signal passes the configured fading channel and then is received by the test antenna, calculate the channel impulse response (CIR). Table 4.2.1.1-1 gives the parameter settings for PDP test.

Table 4.2.1.1-1 RTS PDP Measurement Parameter Settings

| Item | Unit | Value |
|------------------------------|------|--|
| Center frequency | MHz | Downlink Center Frequency in 3GPP TS 36.508 [4] as required per band |
| Interpolation factor for CIR | | 16 |
| Transmission RF power | dBm | -10 |
| Number of CIR averaging T | | 1000 |

Table 4.2.1.1-2 RTS PDP Channel Model Specification

| Item | Unit | Value |
|--------------------------|------|--|
| Center frequency | MHz | Downlink Center Frequency in 3GPP TS 36.508 [4] as required per band |
| Channel model | | As specified in Section 2.4.3 of CTIA 01.40 [5] |
| RX antenna configuration | | Two omni-directional antennas with arbitrary separation |

4.2.1.2 Power Delay Profile Result Analysis

The channel frequency response $H(t, f)$ as linear relative voltage can be measured by the captured received symbols. The analysis is performed by taking the Inverse Fast Fourier transform (IFFT) of each frequency response to generate impulse responses $h(t, \tau)$ for each multi-tone symbol. The resulting impulse responses are averaged in power over the total number of CIR, T , as shown in Equation 4.2.1.2 1 below:

Equation 4.2.1.2 1

$$P(\tau) = \frac{1}{T} \sum_{t=1}^T |h(t, \tau)|^2$$

The resulting time domain data does not have enough resolution to resolve individual taps. In order to obtain an adequate representation of the relative power in each cluster, when applying the IFFT from frequency response to CIR, interpolation is adopted. Parameter of interpolation factor is used to control the delay domain resolution for CIR.

Finally, the resulting PDP is shifted in delay, such that the first tap is on delay zero and normalized so that the peak value is one (zero dB). Finally, convert the PDP relative power to dB.

4.2.1.3 Measurement Antenna

The measurement antenna shall be vertically polarized antenna element of the test antenna.

4.2.1.4 Pass/Fail Criteria

See Section 4.2.1.4 of *CTIA 01.40* [5].

4.2.2 Validation of Doppler/Temporal Correlation for RTS

This measurement checks the Doppler/temporal correlation.

4.2.2.1 RTS Doppler/Temporal Correlation Method of Measurement

Use the setup in [Figure 4.1.3 1](#) to inject single tone signal as specified in [Table 4.2.2.1-1](#) into the input of the internal channel emulator. The channel emulator is configured as specified in [Table 4.2.2.1-2](#). The vertically polarized antenna element of test antenna is used to probe the generated field structure in the center of the test volume and feed that signal to BS emulator RX port. The Doppler power spectrum is measured using the settings provided in [Table 4.2.2.1-3](#) and the result is recorded.

Table 4.2.2.1-1 RTS Doppler/Temporal Correlation Signal Generator Settings

| Item | Unit | Value |
|------------------|------|---|
| Center frequency | MHz | Downlink Center Frequency in <i>3GPP TS 36.508</i> [4] as required per band |
| Modulation | | OFF |

Table 4.2.2.1-2 RTS Doppler/Temporal Correlation Spectrum Analyzer Settings

| Item | Unit | Value |
|-------------------|------|---|
| Center frequency | MHz | Downlink Center Frequency in <i>3GPP TS 36.508</i> [4] as required per band |
| Sampling rate | Hz | 8000 |
| Number of samples | | 8000 |
| Averaging | | 100 |

Table 4.2.2.1-3 Doppler Channel Model Specification

| Item | Unit | Value |
|---|------|--|
| Center frequency | MHz | Downlink Center Frequency in 3GPP TS 36.508 [4] as required per band |
| Channel model | | As specified in Section 2.4.3 of CTIA 01.40 [5] |
| RX antenna configuration | | Two omni-directional antennas with arbitrary separation |
| Mobile speed | km/h | 100 (Note 1) |
| Note 1: Or the maximum achievable value. | | |

The measurement result analysis is performed by taking the Fourier transformation of the Doppler power spectrum measured. The resulting temporal correlation function $R_t(\Delta t)$ is normalized such that $\max(\text{Re}(R_t(\Delta t))) = 1$ and the x -axis is scaled by the mobile speed divided by the wavelength at the center frequency in order to convert the axis from time to wavelengths. The results from the normalized peak of the curve to five wavelengths after that point are then recorded for comparison to the reference curves. The measured results shall fall within the upper and lower limits for the temporal correlation shown in Table 4.2-7 of CTIA 01.40 [5] and plotted in Figure 4.2-1 of CTIA 01.40 [5].

4.2.2.2 RTS Doppler/Temporal Correlation Measurement Antenna

The measurement antenna shall be a vertical-polarized antenna element of the test antenna.

4.2.3 Validation of RTS Spatial Correlation

This measurement checks whether the measured correlation curve follows the theoretical curve.

4.2.3.1 RTS Spatial Correlation Method of Measurement

The method to determine the spatial correlation measurement for RTS does not move and separate antennas in the chamber but emulated the different RX antennas with given antenna separations in the channel emulator, and then generate the channel model coefficients for different positions. Then, the received signals for different antenna configurations are captured and the spatial correlation analysis can be performed.

To emulate the spatial correlation effects caused by different antenna separations between two RX antennas shown in Figure 4.1.3 1, configure a 2x2 channel model with two Tx antenna patterns as suggested in Section 2.4.3 of CTIA 01.40 [5], and configure two RX antennas as vertically polarized omni-directional antenna with different antenna separations. Fix the 1st RX antenna on the position of ($X = 0, Y = 0$), and change the 2nd RX antenna positions from -0.5 to +0.5 wavelengths as ($X = 0, Y = [-0.5: 0.1: 0.5]$) with a step size of 0.1 wavelength.

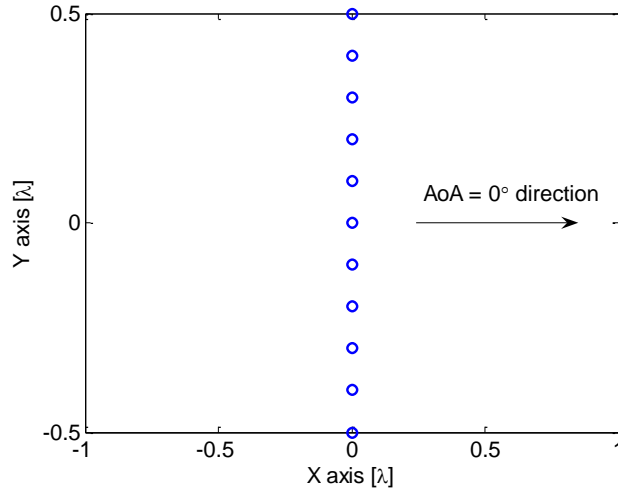

Figure 4.2.3.1-1 RX Antenna Position Configurations

Table 4.2.3.1-1 RTS Spatial Correlation Settings

| Item | Unit | Value |
|--------------------------------------|------|--|
| Center frequency | MHz | Downlink Center Frequency in 3GPP TS 36.508 [4] as required per band |
| Bandwidth | MHz | 30.72 |
| Number of multi-tone symbols | | 10 |
| Number of points in frequency domain | | 512 |
| Averaging | | 1 |

Table 4.2.3.1-2 RTS Spatial Correlation Channel Model Specification

| Item | Unit | Value |
|------------------|------|---|
| Center frequency | MHz | Downlink Center Frequency in 3GPP TS 36.508 [4] as required per band |
| Channel model | | As specified in Section 2.4.3 of CTIA 01.40 [5] |
| Mobile speed | km/h | 30 |
| RX antenna | | Two vertically polarized omni-directional antennas with one on the fixed position (X=0, Y=0), and another on the changed positions (X= 0, Y = [- 0.5: 0.1:0.5]) in 0.1 lambda as the step) |

4.2.3.2 RTS Spatial Correlation Measurement Results Analysis

Calculate correlation of matrix $H1(f)$ and $H2(f)$ of frequency response samples with 11 different antenna separations, where $H1(f)$ and $H2(f)$ are the frequency response samples measured for two test antennas. The procedure for each RX antenna setup is to correlate the two vectors, e.g., using Matlab function `corrcoef`.

```
for posIdx = 1:11;
    Corr (: , : posIdx) = abs(corrcoef(H1(: , posIdx),H2(: , posIdx)));
end

Correlation = squeeze(Corr(1, 2, :));
```

The reference spatial correlation data for the channel model and BS antenna assumptions defined in Sections 2.4.3 and 2.4.4 of *CTIA 01.40* [5] as shown in [Table 4.2.3.2-1](#). The measured spatial correlation data shall fall within the upper and lower limits specified.

Table 4.2.3.2-1 RTS Reference Spatial Correlation Function for SCME Urban Macro

| Separation Distance (Wavelengths) | Ideal Free Space Correlation | Lower Limit | Upper Limit |
|-----------------------------------|------------------------------|-------------|-------------|
| 0.0 | 1.000 | 0.990 | 1.000 |
| 0.1 | 0.952 | 0.925 | 0.975 |
| 0.2 | 0.828 | 0.770 | 0.870 |
| 0.3 | 0.683 | 0.615 | 0.735 |
| 0.4 | 0.583 | 0.530 | 0.640 |
| 0.5 | 0.543 | 0.493 | 0.595 |
| 0.6 | 0.517 | 0.465 | 0.575 |
| 0.7 | 0.467 | 0.410 | 0.540 |
| 0.8 | 0.401 | 0.350 | 0.510 |
| 0.9 | 0.355 | 0.300 | 0.460 |
| 1.0 | 0.342 | 0.290 | 0.450 |

4.2.3.3 RTS Spatial Correlation Measurement Antenna

The measurement antenna shall be a dual-polarized antenna with at least 15dB polarization isolation.

4.2.4 Validation of Cross-Polarization for RTS

This measurement checks how well the measured vertically or horizontally polarized power levels follow expected values.

4.2.4.1 RTS Cross Polarization Method of Measurement

Configure the channel emulator with proper RX antenna and play the emulation. Measure the signal power received by vertically polarized test antenna and horizontally polarized test antenna, then compare the power ratio.

Table 4.2-1 RTS Cross-Polarization Spectrum Analyzer Settings

| Item | Unit | Value |
|------------------|------|--|
| Center frequency | MHz | Downlink Center Frequency in 3GPP TS 36.508 [4] as required per band |
| Span | MHz | 20 |
| Averaging | | 1000 |

Table 4.2-2 RTS Cross-Polarization Channel Model Specification

| Item | Unit | Value |
|--------------------------|------|---|
| Center frequency | MHz | Downlink Center Frequency in 3GPP TS 36.508 [4] as required per band |
| Channel model | | As specified in Section 2.4.3 of CTIA 01.40 [5] |
| Mobile speed | km/h | 30 |
| RX antenna configuration | | Co-located omni-directional antennas, one with vertical polarization and another with horizontal polarization |

4.2.4.2 RTS Cross Polarization Measurement Procedure

- 1 Configure the 2x2 UMa channel model and configure RX antennas in the channel emulator as the co-located omni-directional antennas with orthogonal polarization, 1st RX antenna is vertically polarized and 2nd RX antenna is horizontally polarized. Then play the channel emulation.
- 2 Before the power measurement check the polarization alignment between probe antenna and test antenna, calibrate the pathloss for these two polarizations.
- 3 Measure the absolute power received by the vertically polarized test antenna and the horizontal polarized test antenna at the center of the test zone after path loss compensation, averaged over a statistically significant number of fades.
- 4 Calculate the V/H ratio.
- 5 Compare it with the theoretical value of 8.13 dB for UMa.

4.2.4.3 Cross Polarization Expected Measurement Results

See Section 4.2.4.3 of *CTIA 01.40* [5].

4.2.5 Input Phase Calibration Validation (Normative)

For RTS systems utilizing internal channel emulators or external channel emulators using baseband I/Q interface, multiple output RF channels share the same LO, and the BS downlink signal injected to the internal channel emulator is the baseband signal, so input phase calibration is not necessary.

For RTS systems utilizing external channel emulators, Section 4.2.4 of *CTIA 01.40* [5] applies.

Section 5 Variable RMC MIMO Throughput Test (Informative)

See Section 6 of *CTIA 01.40* [5].

Appendix A Revision History

| Date | Version | Description |
|---------------|---------|--|
| February 2022 | 4.0.0 | Initial release of RTS MIMO OTA test plan. |
| December 2022 | 5.0.0 | No changes in this release. |
| March 2023 | 6.0.0 | No changes in this release. |
| April 2024 | 7.0.0 | No changes in this release. |