



Test Plan for Wireless Device Over-the-Air Performance

CTIA 01.20 Test Methodology, SISO, Anechoic Chamber

Version 6.0.2

June 2024

© 2001 – 2024 CTIA Certification. All Rights Reserved.

Any reproduction, modification, alteration, creation of a derivative work, or transmission of all or any part of this publication ("Test Plan"), in any form, by any means, whether electronic or mechanical, including photocopying, recording, or via any information storage and retrieval system, without the prior written permission of CTIA Certification, is unauthorized and strictly prohibited by federal copyright law. This Test Plan is solely for use within the CTIA Certification Program. Any other use of this Test Plan is strictly prohibited unless authorized by CTIA Certification or its assigns in writing.

Use Instructions

All testing shall be performed in a CTIA Certification Authorized Test Lab and shall be initiated through one of the following methods:

1. By submitting a PTCRB or IoT Network Certified device certification request at <https://certify.ptcrb.com/>
2. By submitting an OTA Test Plan use request at <https://certify.ctiacertification.org/>

CTIA Certification LLC
1400 16th Street, NW
Suite 600
Washington, DC 20036

1.202.785.0081

programs@ctiacertification.org

ctiacertification.org/test-plans/

Table of Contents

Section 1	Introduction	7
1.1	Test Overview	7
1.2	Acronyms and Definition	8
1.3	Referenced Documents	11
Section 2	Scope of Measurements	12
2.1	Transmitter Measurements	12
2.2	Receiver Measurements	12
2.3	General Measurements Details	13
2.4	Conical Cut Test Method	13
2.5	Great Circle Test Method	15
2.6	Special Positioning Considerations for the SAM Phantom Head	18
2.7	Theta Dependent Phi Step Size Optimization	19
Section 3	Test Procedure—Transmitter Performance	20
3.1	Test Procedure for TRP Test	20
3.2	Single Point Offset Test	21
3.3	Multi-point Offset Test	22
3.4	Spiral Scan Procedure for TRP	22
3.5	TRP Measurement of Low Transmit Duty-Cycle Devices	23
3.6	Relative Power on Intermediate Channel Measurements	24
Section 4	Test Procedure—Receiver Performance	26
4.1	Test Procedure for TIS Test	26
4.2	Test Procedure for Intermediate Channel Test	27
4.3	LAA Un-Licensed Degradation (LUD) Test	31
4.4	Single Point Offset Test	33
4.5	Multi-point Offset Test	34
4.6	Alternate Test Procedure for GSM TIS Using Less Than Maximum TX Power	35
4.7	Alternate TIS Test Procedure based on Receive Signal Strength (RSS)	35
4.7.1	RSS Pattern Measurement	36
4.7.2	RSS Pattern Linearization	36
4.7.3	Sensitivity Search	37
4.7.4	RSS Data Format	37
4.7.5	Error Rate Data Format	39
4.7.6	Final TIS Calculation	40
4.8	TIS Measurement of Low Transmit Duty-Cycle Devices	40
4.9	Testing of Cellular Desensitization due to Simultaneous Operation of 802.11 Radios for Integrated Devices	41

4.9.1	Testing Overview	41
4.9.2	Testing Procedure	42
4.9.3	Additional Measurement Uncertainty.....	43
Section 5	Measurement Uncertainty	44
5.1	Introduction	44
5.2	TRP Tests	45
5.2.1	DUT Measurement	45
5.2.2	Reference Measurement	47
5.2.3	Calculation of the Combined and Expanded Uncertainties for the Overall TRP Measurement	48
5.3	TIS Tests	48
5.3.1	DUT Measurement	49
5.3.2	Reference Measurement	50
5.3.3	Calculation of the Combined and Expanded Uncertainties for the Overall TIS Measurement	51
5.4	Alternate Test Procedures for TRP Measurements	52
5.4.1	Single/Multi-point Offset TRP Test	52
5.5	Alternate Test Procedures for TIS Measurements	53
5.5.1	Single/Multi-point Offset TIS Test Procedure	53
5.6	Criteria—Measurement Uncertainty	56
Section 6	Test Set-up Configurations	57
6.1	Test Systems Set-up	57
6.2	Test Setup—Instrumentation	58
Appendix A	Revision History	64

List of Figures

Figure 2.4-1 Conical Cuts and Measurement Points (For a 15 Degree Grid).....	15
Figure 2.5-1 Great Circle Cuts and Measurement Points (For a 15 Degree Grid)	17
Figure 2.5-2 Overlay of Conical Cut and Great Circle Cuts Showing They Produce the Same Measurement Points (For a 15 Degree Grid).....	18
Figure 3.4-1 Spiral Scan Measurement Points (Left) and Standard (Equally Spaced) Measurement Points (Right).....	23
Figure 4.2-1 Illustration Of Relative Sensitivity On Intermediate Channels Test.....	31
Figure 6.1-1 Typical Setup for a Combined-Axes System.....	57
Figure 6.1-2 Typical Setup for a Distributed-Axes System	58
Figure 6.2-1 Simplified Block Diagram Showing a Common Configuration for the Use Of A Communication Tester for TRP Measurements	59
Figure 6.2-2 Simplified Block Diagram Showing a Common Configuration for TIS Measurements.....	59
Figure 6.2-3 Simplified Block Diagram for TRP Measurements Using a Spectrum Analyzer	60
Figure 6.2-4 Simplified Block Diagram for TRP Measurements Using a Spectrum Analyzer with a Power Divider	60
Figure 6.2-5 Simplified Block Diagram Illustrating a Method with External Amplifiers	61
Figure 6.2-6 Simplified Block Diagram for TRP Measurements Using Dual Spectrum Analyzers	61
Figure 6.2-7 Simplified Block Diagram for TRP Measurements Using Dual Spectrum Analyzers and a Power Divider.....	62
Figure 6.2-8 Simplified Block Diagram for TRP Measurements on Dual Connectivity Using a Spectrum Analyzer.....	62
Figure 6.2-9 Simplified Block Diagram Showing a Common Configuration for Tis Measurements on Dual Connectivity	63

List of Tables

Table 1.2-1 Acronyms and Definitions	8
Table 2.5-1: Number of Great Circle Cuts Required for Various Degree Intervals for the Great Circle Test Method.....	16
Table 2.7-1: Illustration of the Theta-Dependent Phi Step Size Optimization (With Optimized ϕ Starting Angles)	19
Table 3.1-1: Applicability of TRP Measurement Grids	20
Table 4.1-1: Applicability of TIS Measurement Grids	27
Table 5.1-1 Standard Uncertainty Conversion Factors.....	44
Table 5.2.2-1 Standard Uncertainties for the Contributions to the Reference Measurement.....	47
Table 5.3.2-1 Standard Uncertainties for the Contributions to the Reference Measurement.....	51
Table 5.4.1-1 Additional Uncertainties Between Relative Measurement vs. Full TRP Measurement.....	52
Table 5.5.1-1 Additional Uncertainties Between Relative Measurement vs. Full TIS Measurement	55
Table 5.6-1 Expanded Uncertainty Maximum Limits for Different Configurations for TRP and TIS.....	56

Section 1 Introduction

1.1 Test Overview

This test plan presents the individual test procedures organized by type of test (Transmitter, Receiver) and/or technology (LTE, NR, etc.).

The testing requirements fall into 3 categories:

1. Measuring the basic performance of the test chamber,
2. Measuring the path loss of the test system, and
3. Measuring the performance of the wireless device.

The basic performance of the test chamber is covered in Section 5 of *CTIA 01.73* [1], and includes a site validation method used to determine the uncertainty contribution of the test system.

Corrections for the path loss of the test system, including range length, measurement antenna, cables, amplifiers, etc. are determined using the range reference measurement described in Section 2 *Range Reference Requirements* in *CTIA 01.73* [1]. This measurement uses a calibrated reference antenna to determine a relative correction value that can then be applied to measurement instrument readings in order to determine the performance of the wireless device relative to a theoretical isotropic radiator or receiver.

The measurement of the wireless device is covered in *CTIA 01.50* [2] for Wireless Technology, 3GPP Radio Access Technologies, *CTIA 01.51* [3] for Location Based Technologies, and *CTIA 01.52* [4] for Non-3GPP Radio Access Technologies. The testing of cellular desensitization due to simultaneous operation of 802.11 radios is covered in Section 4.9. The test procedures for Radiated Power and Receiver Performance are covered in Section 3 and Section 4. On completion of the three measurement categories, the results are processed as described in Section 3 in *CTIA 01.90* [9], Calculating Spatially Averaged Quantities.

The overall measurement uncertainty is calculated in the manner described in Section 5 (using *CTIA 01.70* [5] as a guide).

The test report requirements are defined in *CTIA 01.01* [6].

1.2 Acronyms and Definition

The following specialized terms and acronyms are used throughout this document.

Table 1.2-1 Acronyms and Definitions

Acronym/Term	Definition
A-GNSS	Assisted GNSS
ASCII	American Standard Code for Information Interchange
ATL	Authorized Test Lab
BER	Bit Error Rate
BHHR	Beside Head and Hand Right Side (Head and Hand Phantom)
BLER	Block Error Ratio
CA	Carrier Aggregation
C-TIS	Combined Total Isotropic Sensitivity
dB	decibel
dBm	decibel milliwatts
DUT	Device Under Test
EGPRS	Enhanced GPRS
EIRP	Effective Isotropic Radiated Power
EIS	Effective Isotropic Sensitivity
ETSI	European Telecommunications Standards Institute
FER	Frame Error Rate
FS	Free Space
GNSS	Global Navigation Satellite System
GPRS	General Packet Radio Services
GPS	Global Positioning System
GPS L1	GPS L1 navigation signal with carrier frequency of 1575.420 MHz
GSM	Global System for Mobiles
HL	Hand Left (Hand Phantom Only)
HR	Hand Right (Hand Phantom Only)

Acronym/Term	Definition
ISO	International Organization for Standardization
I-TIS	Individually measured TIS
LAA	License Assisted Access
LTE	Long Term Evolution
LUD	LAA Un-Licensed Degradation
MBS	Metropolitan Beacon System
MU	Measurement Uncertainty
mW	milliwatts
NHPIS	Near-Horizon Partial Isotropic Sensitivity
NHPRP	Near-Horizon Partial Radiated Power
NR	New Radio
PCS	Personal Communications Service
PIGS	Partial Isotropic GNSS Sensitivity
PRP	Partial Radiated Power
RAM	Random Access Memory
RB	Resource Block
RBER	Residual Bit Error Rate
RF	Radio Frequency
RMS	Root Mean Square
RSS	Receive Signal Strength
RSSI	Receive Signal Strength Indicator
RX	receive
SAM	Specific Anthropomorphic Mannequin
SISO	Single Input Single Output
SME	Subject Matter Expert
SPOT	Single Point Offset Testing
TIS	Total Isotropic Sensitivity

Acronym/Term	Definition
TRP	Total Radiated Power
TX	transmit
UE	User Equipment
UHS	Upper Hemisphere Isotropic Sensitivity
UMTS	Universal Mobile Telecommunications System
VSWR	Voltage Standing Wave Ratio
WCDMA	Wideband Code Division Multiple Access

1.3 Referenced Documents

The documents in this list are either cited (indicated by hyperlink references) or relevant to this test plan.

Document Number, Name	
[1]	CTIA 01.73, Ancillary Procedures
[2]	CTIA 01.50, Wireless Technology, 3GPP Radio Access Technologies
[3]	CTIA 01.51, Wireless Technology, Location Based Technologies
[4]	CTIA 01.52, Wireless Technology, Non-3GPP Radio Access Technologies
[5]	CTIA 01.70, Measurement Uncertainty
[6]	CTIA 01.01, Test Scope, Requirements, and Applicability
[7]	CTIA 01.71, Positioning Guidelines
[8]	CTIA 01.72, Near-Field Phantoms
[9]	CTIA 01.90, Informative Reference Material
[10]	CTIA 01.03, Reporting Tables
[11]	3GPP TS 36.521-1, Evolved Universal Terrestrial Radio Access (E-UTRA); User Equipment (UE) conformance specification; Radio transmission and reception; Part 1: Conformance testing
[12]	Guide to the Expression of Uncertainty in Measurement published by the International Organization for Standardization (ISO) Geneva, Switzerland 1995.
[13]	ETSI TR 102 273-2, Electromagnetic compatibility and Radio spectrum Matters (ERM); Improvement on Radiated Methods of Measurement (using test site) and evaluation of the corresponding measurement uncertainties; Part 2: Anechoic chamber
[14]	ETSI TR 100 028, Electromagnetic compatibility and Radio spectrum Matters (ERM); Uncertainties in the measurement of mobile radio equipment characteristics Part 1
[15]	3GPP TS 36.101, Evolved Universal Terrestrial Radio Access (E-UTRA); User Equipment (UE) radio transmission and reception

Section 2 Scope of Measurements

Good radiated performance is critical to the effective operation of a wireless device in today's networks. As devices become smaller, radiated performance can often become compromised. For example, achieving an efficient antenna in a small size and over multiple frequency bands is a difficult task. A comprehensive and accurate characterization of radiated performance will enable carriers and manufacturers to determine how well wireless devices will work within the constraints of a specific cellular network design.

Generally, peak EIRP (Effective Isotropic Radiated Power) is not a good indication of wireless performance in the field. For example, if the radiation pattern of the Device Under Test (DUT) 's antenna system is highly directive, the peak EIRP would be high (since the antenna gain is high in one direction), but coverage would be poor in other directions. In a cellular environment it is best to maximize the spatial coverage of the antenna system so that the user does not have to point the antenna in one particular direction to get good call performance. Further, the human head and/or hand can alter the shape and peak value of the DUT radiation pattern. Losses due to the head and/or hand can vary significantly with frequency, device size, and antenna design implemented. From a field performance perspective, measurement of the average EIRP on a head and/or hand model is more meaningful than measurement of peak EIRP in free-space conditions. This test plan requires average spherical effective isotropic radiated power (termed Total Radiated Power, TRP) to be measured.

Receiver performance, or EIS (Effective Isotropic Sensitivity) is as important to the overall system performance as transmitter performance. The downlink receive path is integral to the quality of the device's operation. Poor receiver radiated performance will cause the user of the subscriber unit to hear a low-quality voice signal. This can also cause the subscriber unit to lose the base station signal resulting in abrupt termination of the call. This test plan requires average spherical effective radiated receiver sensitivity (termed, in the general sense, Total Isotropic Sensitivity, TIS) to be measured. A frequent cause of poor sensitivity on a single channel, or a small number of channels, is due to receiver in-band noise, or spurious signals from the transmitter itself being radiated back into the receiver. The receiver sensitivity will be measured with the transmitter set to the maximum power output allowed by the particular DUT and technology combination.

The procedures defined herein will a) evaluate the inherent performance of the test chamber used for the measurements; b) detail the measurements of the transmitter performance (as TRP) and receiver performance (as TIS) for the wireless device (measuring wireless performance in free-space and/or with phantoms where appropriate); c) detail the method for calculation of the associated measurement uncertainty.

2.1 Transmitter Measurements

The transmitter performance of the DUT is measured by sampling the radiated transmit power of the mobile at various locations surrounding the device. A three-dimensional characterization of the 'transmit' performance of the DUT is pieced together by analyzing the data from the spatially distributed measurements in spherical coordinates (see Section 5.2 in *CTIA 01.73 [1]* for an introduction to spherical coordinates).

2.2 Receiver Measurements

The receiver performance of the DUT is measured utilizing Bit Error Rate (BER), Block Error Rate (BLER), or other error criteria. This test specification uses the appropriate error criteria to evaluate effective radiated receiver sensitivity at each spatial measurement location. A three-dimensional characterization of the receiver performance of the DUT is pieced together by analyzing the data from the spatially distributed measurements in spherical coordinates (see Section 5.2 in *CTIA 01.73 [1]* for an introduction to spherical coordinates).

Some digital technologies and/or DUT s may not allow the measurement of error criteria without special procedures for controlling the DUT. In this case, external cables and manual test commands may be applied to the DUT for setup purposes only. All such cables must be removed and the DUT operated in stand-alone battery powered mode during the data collection process.

2.3 General Measurements Details

There are two common measurement sequences used to cover the surface of a sphere around the DUT with a uniformly spaced angular resolution. Each of these may be more or less practical for a given positioning system, and the measurement antenna may be moved relative to the DUT by moving either the DUT or the measurement antenna, or both, in one or both axes of the spherical coordinate system. In the case of the measurement antenna, “motion” may occur either by mechanical means to reposition the measurement antenna or by electronic means to switch between different measurement antennas. See Section 5.4 in *CTIA 01.73* [1] for additional information on common positioning system architectures. In the “conical” cut method, the measurement antenna is moved relative to the DUT, first in theta and then through all phi positions for that theta position. In the “great circle” cut method, the measurement antenna is moved relative to the DUT, stepping through all theta positions for each phi position. Section 2.4 describes the conical cut method; Section 2.5 describes the great circle cut method. The test configurations detailed in *CTIA 01.71* [7] are suggested testing methods; alternative positioning methods that yield data samples at the specified angular locations with similar polarization properties are acceptable. Alternately, data point reduction methods that reduce the measured data points near $\theta = 0^\circ$ and $\theta = 180^\circ$ while maintaining the effective surface resolution required for a given test may be used, although additional uncertainty contributions may be required.

TRP, TIS, and all near the horizon or partially integrated quantities in this test plan shall use the constant step size grid except when using the spiral scan procedure or the theta-dependent-phi step size optimization. More detailed information is in Section 2.7 and Section 3.4 of this document and in Section 3 of *CTIA 01.90* [9]. Each cut will be measured along the theta axis for the great circle cut method, and along the phi axis for the conical cut method. Although the data is gathered in a different order, the resultant data from both methods is measured at the same (θ, ϕ) points and is processed in the same manner. The measurement antenna should be capable of measuring in two orthogonal linear polarizations, E-phi and E-theta. These two polarizations may be measured during a single DUT rotation or during subsequent rotations.

The overall measurement of the DUT makes use of the data obtained from *CTIA 01.73* [1] to normalize the measured performance of the DUT performed over a spherical surface with the DUT ‘s antenna centered in the sphere. A communication tester is used to establish a wireless signaling connection to the DUT and to request reports of signal strength that the DUT is measuring on the ‘receive’ frequency of the call. These two measurements may be taken individually or together as part of a single set of sampling scans. Data is collected and stored during the measurement step for delivery with the test report for each device tested.

The overall test requirements are defined in Section 2.1 in *CTIA 01.01* [6]. Coordinate systems and positioning requirements for all configurations are described in *CTIA 01.71* [7]. Special care should be taken to ensure the center of rotation is set appropriately for each test case (see *CTIA 01.71* [7]) (e.g., about the ear reference point for testing of phones in free space and with the head phantom). The requirements for the near-field phantoms are defined in *CTIA 01.72* [8].

2.4 Conical Cut Test Method

Figure 2.4-1 shows a diagram of the conical cut measurement method. The number of conical cuts required to capture data at various degree intervals are tabulated in Table 2.4-1; with the top (theta = 0 degrees) and bottom (theta = 180 degrees) positions only requiring the measurement of a single data point each.

Table 2.4-2: Number of conical cuts required for various degree intervals for the conical cut test method

Degree Intervals [°]	Number of Conical Cuts
15	11
30	5
45	3

For systems that are unable to reach the $\theta = 180$ degree position (i.e. for devices mounted to a pedestal which prevents the measurement antenna from reaching $\theta = 180$ degrees), the value at that point may be extrapolated from the average of the neighboring conical cut or from two opposing points adjacent to the 180 degree position. Typically, the DUT will be mounted to a low loss dielectric structure and positioned in the center of the test volume. The measurement antenna will be positioned at a starting θ angle (e.g. zero degrees) relative to the DUT. The DUT will then be rotated relative to the measurement antenna around the full 360 degrees of ϕ rotation. The measurement antenna will then be positioned at the next θ angle relative to the DUT, and the process repeated until all conical cuts have been measured. Note that there is no particular requirement on the test system as to whether the DUT moves in both axes, the DUT moves in one and the measurement antenna in the other, or the measurement antenna moves in both axes.

Measurements of the radiated transmit power and receiver sensitivity should be recorded in both E- θ and E- ϕ polarizations simultaneously to reduce measurement uncertainties due to DUT repositioning. The DUT will report the power it measures in the receive-band by sending a message to the communication tester (for technologies that support this function).

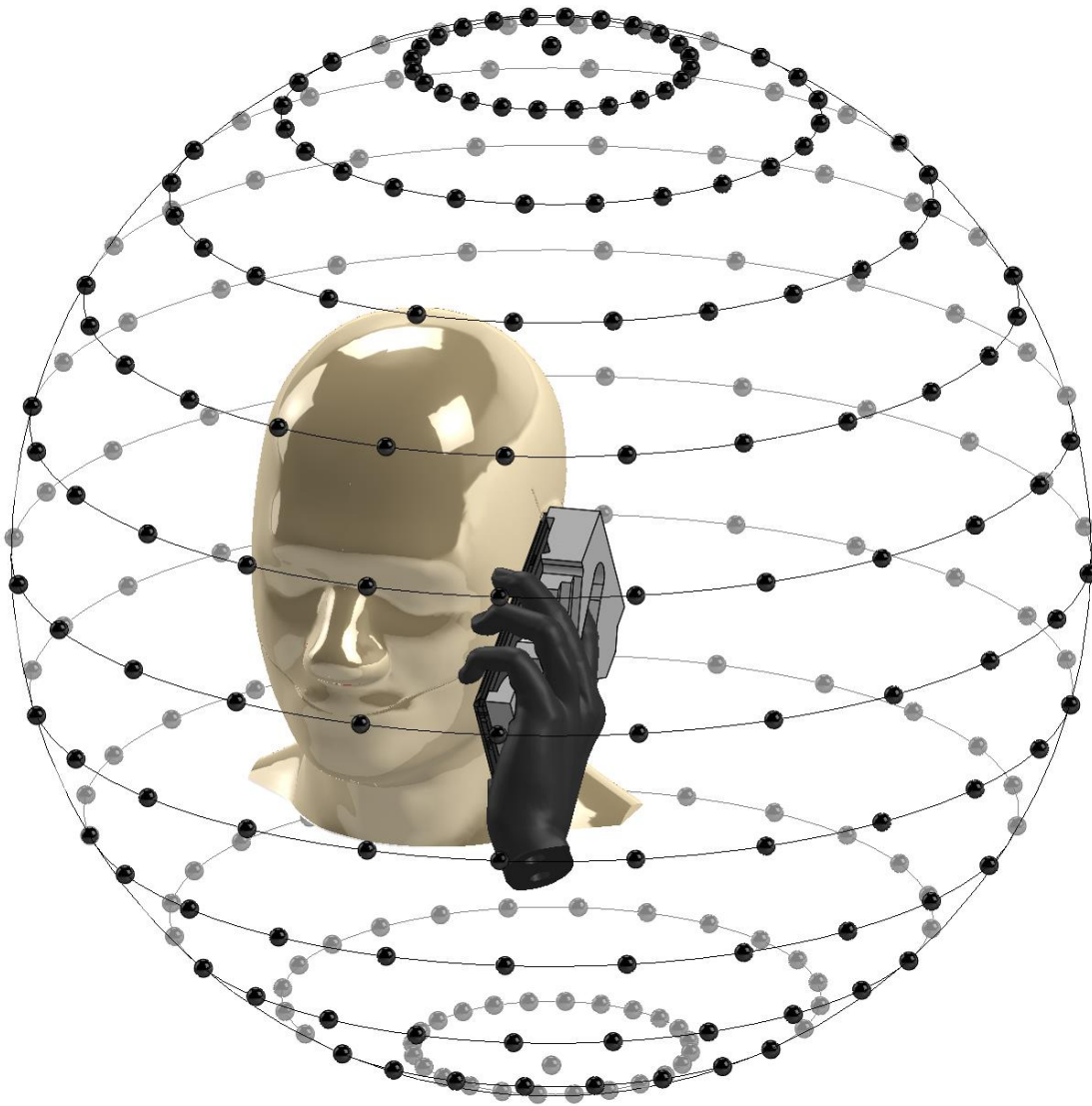

Figure 2.4-1 Conical Cuts and Measurement Points (For a 15 Degree Grid)

2.5 Great Circle Test Method

Figure 2.5-1 shows a diagram of the great circle cut measurement method. While originally envisioned as an approach for manually adjusting the phi position for an DUT on a turntable positioner serving as the theta axis, today, this method is primarily used for automated test systems where positioning in theta is faster than rotating the positioner in phi. The number of great circle cuts required to capture data at various degree intervals are tabulated in Table 2.5-1.

Table 2.5-2: Number of Great Circle Cuts Required for Various Degree Intervals for the Great Circle Test Method

Degree Intervals [°]	Number of Great Circle Cuts
15	12
30	6
45	4

The points at the top (theta = 0 degrees) and bottom (theta = 180 degrees) positions only need to be measured once. If they are measured repeatedly for each great circle cut, they may be averaged together as all other phi cuts in post processing. For systems that are unable to reach the theta = 180 degree position (i.e. for devices mounted to a pedestal which prevents the measurement antenna from reaching theta = 180 degrees), the value at that point may be extrapolated from the average of the neighboring two points, or the neighboring conical cut value in post processing.

Note that the great circle cut test method will measure exactly the same (theta, phi) points as those measured by the conical cut method (see [Figure 2.5-2](#)), and although the data is captured in the great circle cut order, the calculation of the spatially averaged quantities described in Section 3 in *CTIA 01.90 [9]* will require the results to be reordered into conical cuts.

Wherever possible, measurements of the radiated transmit power and receiver sensitivity should be recorded in both E-theta and E-phi polarizations simultaneously to reduce measurement uncertainties due to DUT repositioning. The DUT will report the error criteria or the measurements needed to calculate the error criteria that it measures in the receive-band by sending a message to the communication tester (for technologies that support this function).

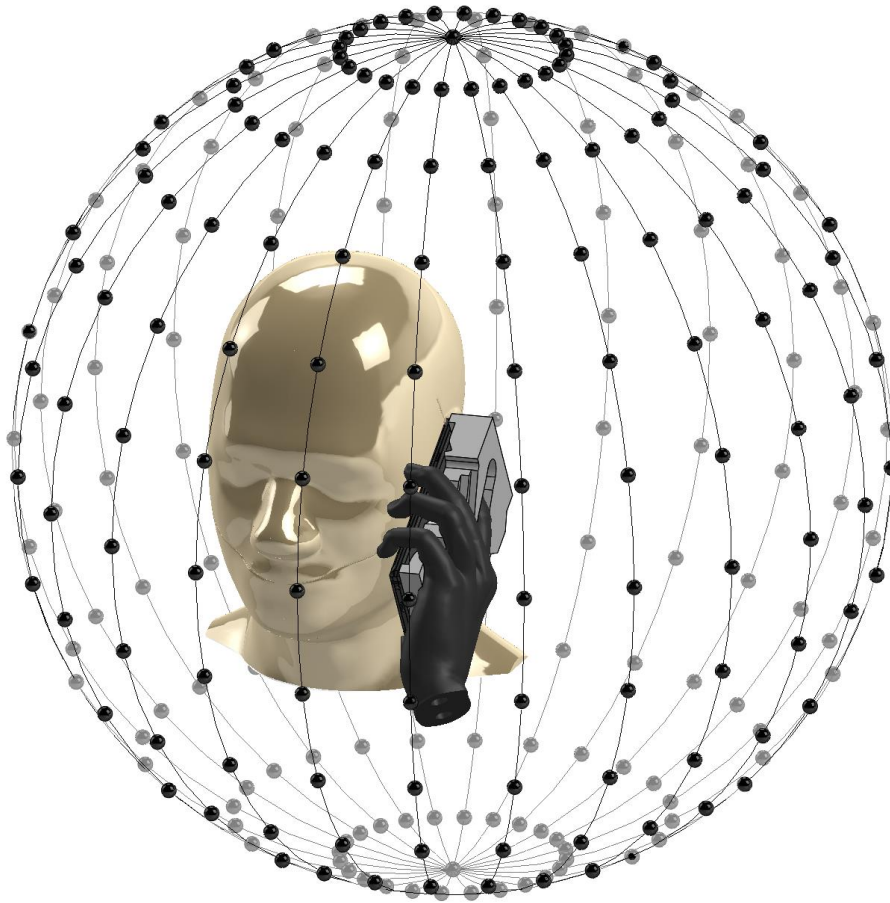

Figure 2.5-1 Great Circle Cuts and Measurement Points (For a 15 Degree Grid)

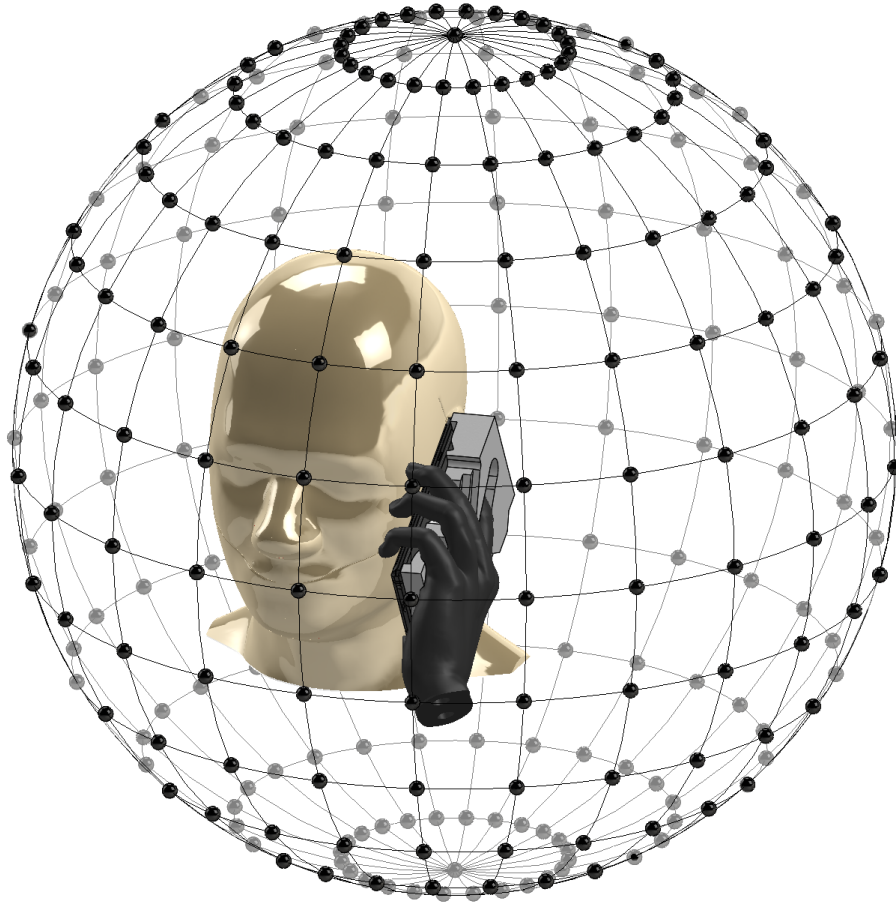

Figure 2.5-2 Overlay of Conical Cut and Great Circle Cuts Showing They Produce the Same Measurement Points (For a 15 Degree Grid)

2.6 Special Positioning Considerations for the SAM Phantom Head

Measurement variability may also be attributed to the level of fluid in the head phantom; especially when the head phantom is positioned horizontally (e.g. combined axis positioning systems). To minimize measurement uncertainties, air bubbles in the head phantom should be eliminated by completely filling the head phantom with fluid (see Section 2.1.3 in *CTIA 01.72* [8] for more details on requirements on the air bubbles in the head phantom).

While gel filled phantoms are common today, for liquid filled phantoms used with positioning systems that mount the phantom head sideways (e.g. combined axis positioning systems), special care should be taken to avoid a situation where a bubble in the phantom fluid impacts the measurement. Using great circle acquisition mode, selecting great circle cuts with the DUT near the bottom will ensure that the air bubble remains at the top away from the DUT, and the test will not be influenced by the presence of an air bubble. In conical cut case, a bubble could move near the DUT on each phi axis cut. In this case it can be ensured that the test will not be influenced by the presence of an air bubble, provided a regular maintenance procedure for checking (and refilling if necessary) the head phantom is in place and a hard limit on the size of the air bubble is imposed. See *CTIA 01.72* [8] Section 2.1.3 for air bubble requirements. As long as this requirement is met, both the great circle or conical cut methodology may be used on a head phantom with orientations other than vertical.

2.7 Theta Dependent Phi Step Size Optimization

An optional data point reduction optimization can be used for measurements performed using a conical cut acquisition process in order to improve test time by as much as 25-35%. In this case, the ϕ angle step size can be varied as a function of the θ position according to the formula:

$$N_{\phi}(\theta) = 1 + \text{int}\{[N_{\phi}(90^{\circ}) - 1] \sin(\theta)\}$$

where $N_{\phi}(\theta)$ is the minimum number of points at any given θ position, $N_{\phi}(90^{\circ})$ is defined as 360° divided by the chosen ϕ angle step size, and $\text{int}()$ refers to taking the integer portion of the result within the parentheses. The ϕ angle step size for this θ angle is then given by $360^{\circ}/N_{\phi}(\theta)$. The target positions may be rounded to the nearest whole degree if desired. It is also allowable to increase the number of steps for any given θ angle over the minimum defined above in order to align the angular ϕ positions to even positions for one or more ϕ cut(s), allowing the optimization to be used for great circle cuts as well.

The number of unique measurement grid points for a grid with 15, 30, and 45-degree intervals in θ is 182, 46, and 20, respectively, which are visualized in Table 2.7-1.

Table 2.7-1: Illustration of the Theta-Dependent Phi Step Size Optimization (With Optimized ϕ Starting Angles)

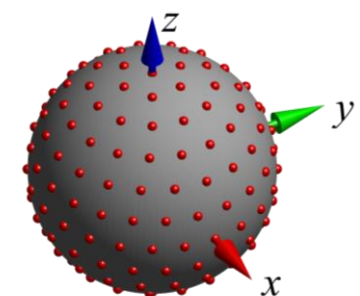
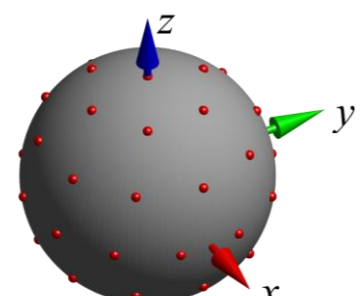
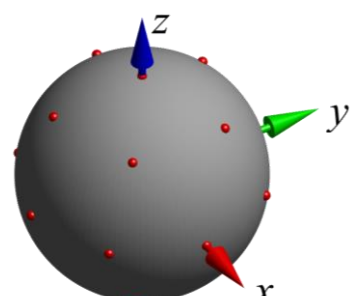
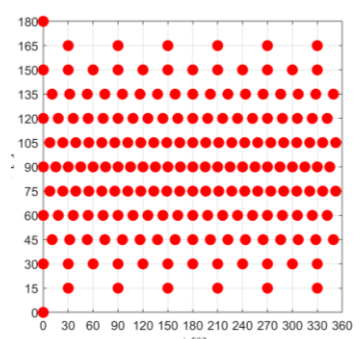
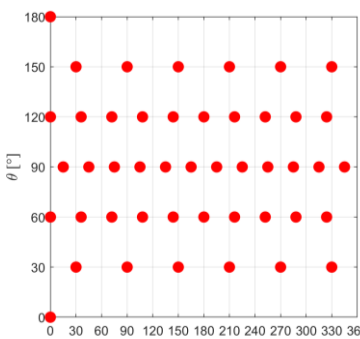
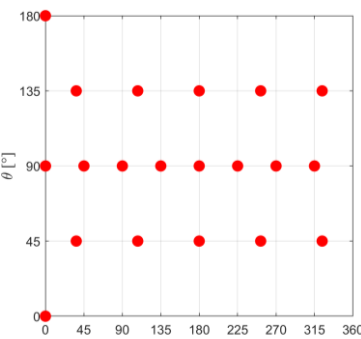
	182 grid points ($\Delta\theta = 15^{\circ}$)	46 grid points ($\Delta\theta = 30^{\circ}$)	20 grid points ($\Delta\theta = 45^{\circ}$)
3D View			
2D View			

Section 3 Test Procedure—Transmitter Performance

DUTs shall be tested in free-space and/or with phantoms as defined in *CTIA 01.72* [8] as required in *CTIA 01.01* [6] using the positioning guidelines described in *CTIA 01.71* [7] for all the test procedures mentioned in this section. The calculation of the figures of merit for transmitter performance are defined in Section 3 in *CTIA 01.90* [9].

3.1 Test Procedure for TRP Test

Unless otherwise noted, all evaluations shall be performed at maximum transmit power.

Products supporting multiple air-interface technologies shall be tested in accordance with all relevant test procedures. Test results shall be provided for each test performed in the format defined.

It is recommended that one of the two following steps be taken to properly characterize the impact of transmit power drift due to thermal heating.

1. Perform the TRP test concurrently with the TIS test, except where different configurations are used for TRP and TIS (e.g. LTE and NR).
2. Allow the phone to warm up by turning the transmitter to maximum power for 5 minutes prior to conducting the TRP test.

The TRP measurement grid applicability, i.e., the step size taken in the theta (θ) and in the phi (ϕ) axes deemed sufficient to fully characterize the DUT 's Far-Field radiation pattern and Total Radiated Power, is outlined in [Table 3.1-1](#). Selecting finer measurement grids is not precluded All of the measured power values will be integrated to give a single figure of merit referred to as TRP.

Table 3.1-2: Applicability of TRP Measurement Grids

Applicability Condition	Measurement Grid Step Size $\Delta\theta$ [°]	Unique Number of Measurement Points with Constant Angular Step Size, Section 3.1.1 of <i>CTIA 01.90</i> [9] $\Delta\theta = \Delta\phi$ [°]	Unique Number of Measurement Points with Theta Dependent Phi Optimization, Section 2.7 and Section 3.1.2 of <i>CTIA 01.90</i> [9]
Below 3 GHz and Device Size \leq 30 cm	30	62	46
Below 3 GHz and Device Size $>$ 30 cm	15	266	182
Above 3 GHz	15	266	182

The goal of the transmitter test is to measure TRP with a measurement uncertainty of no more than the values specified in [Table 5.6-1](#).

Following alternate test procedures can significantly reduce the test time for TRP.

Use of these alternate test methods may require additional measurement uncertainty calculations, which are discussed in [Section 5.4](#).

The calculation of the figures of merit for transmitter performance are defined in Section 3 in *CTIA 01.90* [9].

3.2 Single Point Offset Test

This offset test procedure significantly reduces the test time for TRP for multi-protocol phones, which have more than one protocol in the same frequency band. This offset test procedure can be used to determine the offset in TRP between different protocols on equivalent channels. “Equivalent channels” assumes that the two channels are close enough in frequency that the pattern does not change. This method may be used between stand-alone LTE and LTE CA or one LTE CA combination and another, when the same band, channel and RB allocation combination is evaluated in both LTE combinations if single point offset testing (SPOT) is allowed for the CA combination as specified in the operator CA combination priority list identified in *CTIA 01.01* [6].

This offset test procedure for TRP cannot be used with an antenna which uses a different physical radiator, or different aperture tuning (e.g. matching on parasitic elements or matching components on the ground or within the radiator) between the reference protocol and the protocol being evaluated. This offset test procedure cannot be used in this case because the antenna pattern will generally be different between the 2 protocols.

This offset test procedure for TRP can be used with an antenna which uses the same physical radiator, the same aperture tuning (e.g. matching on parasitic elements or matching components on the ground or within the radiator) but uses different impedance matching (e.g. matching components on the RF feed) between the reference protocol and the protocol being evaluated,

The manufacturer must declare to the ATL when antennas are implemented in such a way that this offset test procedure for TRP cannot be used, when single point offset tests are considered.

It is recommended that voice digital protocols be given priority when doing full TRP measurements. For purposes of clarity for the following test procedure, test configuration A will be the reference protocol for which a full TRP measurement is performed. Test configuration B will be the other protocol to be tested using the single point radiated test.

Either test sequence is repeated for each channel specified in the appropriate part of *CTIA 01.50* [2]. Either test sequence shall be repeated for each DUT antenna configuration (free space, head and hand phantom, hand phantom only, whip extended, whip retracted). The single/multi point radiated power for both test configurations, the difference, and the calculated TRP for test configuration B shall be recorded.

The TRP test for test configuration A shall be completed first according to the appropriate part of *CTIA 01.50* [2].

After identifying the position and polarization for which the DUT has its maximum radiated power for one channel, the DUT should be placed in the same configuration. A radiated power measurement shall be first performed in test configuration A according to the relevant procedures in *CTIA 01.50* [2]. If possible without touching the phone, initiate a hand-off or change to test configuration B at the equivalent channel. Otherwise, initiate a call in test configuration B and go to the equivalent channel. If the phone must be handled in order to initiate a call in test configuration B, then an additional repositioning uncertainty must be included to account for positioning repeatability. Following that, a radiated power measurement shall be performed in test configuration B according to the relevant procedures in *CTIA 01.50* [2]. The two measurements shall be conducted as close in time as possible. The difference between these radiated tests shall then be used as an offset to the TRP for test configuration A in order to calculate the TRP for test configuration B.

Note: *This test procedure is well suited for pairs of test configurations where hand-offs to and from each test configuration are both not possible.*

3.3 Multi-point Offset Test

This offset method has similar benefits as the Single-Point Offset Test in Section 3.2 and has the same restrictions as discussed in Section 3.2.

Multiple positions and polarizations shall be predetermined for comparing test configurations A and B. The test positions and polarizations shall be selected such that they are spread relatively evenly in time throughout the TRP test and are spread relatively evenly in space over the sphere. While the TRP test for test configuration A is being performed, measurements for test configuration B will be performed at those predetermined positions and polarizations. This is accomplished at those predetermined positions and polarizations by:

1. Measuring the radiated power for test configuration A.
2. Handing-off or changing to test configuration B.
3. Measuring the radiated power for test configuration B.
4. Handing-off or changing to test configuration A.
5. And finally continuing the TRP test until another predetermined position and polarization is to be tested, at which time, steps 1 to 5 are repeated.

The handset shall not be moved between handoffs between configuration A and B and back. Exclude measurement points, which are less than 20 dB above the noise floor, for use in this multi-point test. The difference between the averages of the radiated tests at the predetermined positions and polarizations shall then be used as an offset to the TRP for test configuration A in order to calculate the TRP for test configuration B.

Note: *This test procedure is well suited for pairs of test configurations where hand-offs to and from each test configuration are both possible.*

Note: *More than four test positions/polarizations are recommended to keep the measurement uncertainty low.*

Note: *This test procedure using multiple test positions/polarizations will have lower uncertainty than the test procedure using a single test position/polarization.*

3.4 Spiral Scan Procedure for TRP

Editor's Note: Spiral scan procedure with coarser measurement grid is for future study.

This alternate test procedure significantly reduces the test time for TRP when used in conjunction with appropriate measurement systems. This method relies on continuous rotation of both the theta and phi positioner during the collection of data points. Power measurements on the measurement antenna for both the theta and phi polarizations may be taken simultaneously or in rapid succession. Alternately, each polarization may be measured for a complete spiral and the computed spherical quantities for each polarization may then be combined to obtain the total metrics. In either case, the measurement location (theta, phi) shall be recorded for each measurement point along with the measurement value.

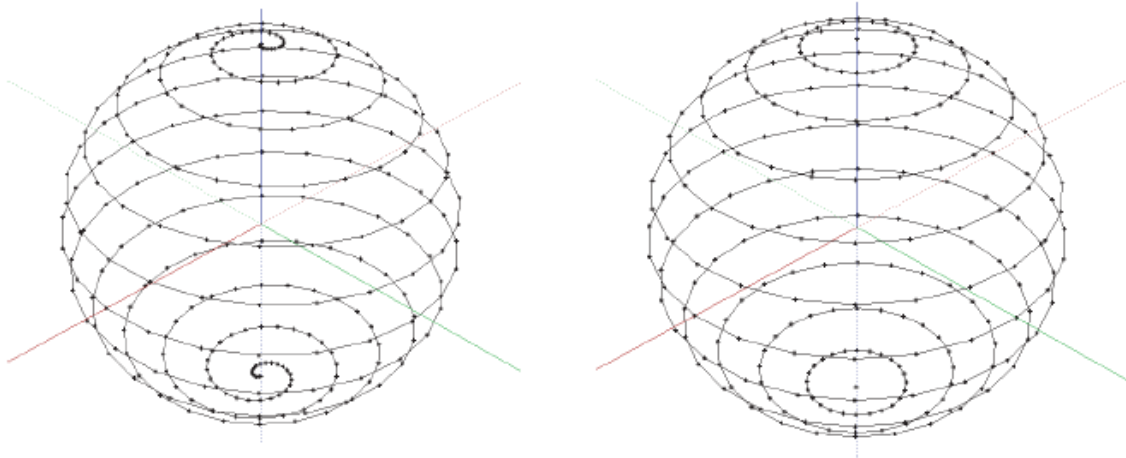

Figure 3.4-1 Spiral Scan Measurement Points (Left) and Standard (Equally Spaced) Measurement Points (Right)

The spiral scan TRP procedure may be used without respect to communication protocol.

Due to the nature of the test systems being used, it is not required that point spacing when using the spiral scan be exactly 15 degrees. However, equal spacing of the test points shall be prioritized and the following criteria shall be achieved:

1. The maximum theta rotation between subsequent turns in the spiral at the same phi angle shall be 15 degrees for each polarization.
2. The maximum spacing between adjacent points in phi for each polarization shall be 15 degrees.
3. Points shall be oversampled relative to the standard 15 degree spacing, such that the minimum number of total measurement locations shall be 350 (x 2 polarizations = 700 total data points).

This alternate test method does not require additional measurement uncertainty calculations.

3.5 TRP Measurement of Low Transmit Duty-Cycle Devices

An underlying assumption in the TRP test methodologies described in *CTIA 01.50* [2]. Is that the DUT is capable of supporting a moderate to high transmit duty-cycle during normal operation. However, some DUTs are designed to transmit at full power for only a fraction of each hour, and as a result, typically have a very small heatsink for the power amplifier and a relatively low-capacity battery. Attempts to measure TRP using the current CTIA methodology will, in many cases, cause the DUT to be damaged due to excessive heat.

The TRP test methodology described below applies only to DUTs which have insufficient power/thermal capacity to maintain the cellular link for at least 50% of the execution time of a single-channel TRP or TIS test. This methodology applies regardless of cellular radio mode, so it may be utilized, as applicable, for any DUT which would otherwise be tested according to *CTIA 01.50* [2].

1. If the DUT supports multiple cellular radio modes, determine which cellular radio mode includes the highest number of CTIA normative bands. If more than one cellular radio mode supports the same number of bands, the highest-order supported cellular radio mode (e.g. LTE > UMTS) shall be selected to begin this TRP test procedure.

2. Configure the network simulator so that the DUT output power will be approximately 10 dB below full output power. It's not necessary to set the uplink power to exactly 10 dB below full-power, it's only necessary to ensure that the DUT 's uplink power setting on the network simulator is known and maintained through the execution of all subsequent tests, except as noted. The recommended device warm up time described in Clause 5 of this document should be applied to the reduced output power.
3. With the network simulator set to command the DUT to operate at a reduced output power as noted in Step 2, execute the TRP measurement process in one of the DUT 's supported bands following the CTIA procedure for the airlink under test. This TRP is called *TRP_{protocol tested with reduced power}*.
4. Once radiated power data from all measurement points have been collected, determine the peak in the DUT 's antenna pattern and orient the measurement antenna(s) to the peak associated with the low-frequency measurement channel.
5. With the measurement antennas at the low-frequency antenna pattern peak as described in Step 4, obtain a single radiated power measurement at reduced power (*EIRP_{red.power}*). Document the DUT 's radiated power at this measurement location for reduced power.
6. Command the DUT to transmit at full-power only long enough to obtain a single radiated power measurement on the low-frequency reference channel. Document the radiated power at this measurement location for full power (*EIRP_{full power}*).
7. Repeat Step 5 and 6 for all other cellular radio modes supported by the DUT in this band and which are required to be tested.
8. Repeat Steps 3 through 7 for the remaining reference channels in the selected band, using the measurement antenna locations corresponding to the peak in the DUT 's antenna pattern at each reference frequency.
9. If any subsequent cellular radio modes include bands not tested in Steps 2 through 8, follow a similar TRP measurement methodology for the previously-untested band(s) or cellular radio mode(s).
10. Once all EIRP measurement data have been obtained, compare the EIRP at the peak of the antenna pattern while operating at full power (*EIRP_{full power protocol X}*) in each of the reference channels to the power measured at these measurement antenna positions (corresponding to the peak in the DUT's pattern) at reduced power (*EIRP_{red.power protocol X}*). Document the reduction in radiated power (if any, in dB) between full and reduced power. This is done for all tested protocols.
11. Calculate TRP for the DUT in the following way for all protocols and reference channels.

$$TRP_{protocol X} = TRP_{protocol tested with reduced power} + EIRP_{full power protocol X} - EIRP_{protocol tested with red.power}$$

Only one protocol is tested for TRP with reduced power per band. The TRP for all other protocols is determined using the above equation.

3.6 Relative Power on Intermediate Channel Measurements

For wide frequency TDD bands, EIRP measurements will be repeated per channel for the specified list of intermediate channels as described in *CTIA 01.50 [2]*, Table 5.1.1.1.1-1.

The procedure for measuring EIRP on intermediate channels:

1. Set DUT as defined in *CTIA 01.50* [2] to ensure maximum output power during the test.
2. Move the DUT and chamber positioner(s) to the location and polarization resulting in the best radiated free-space EIRP measured for the closest, in frequency, fully measured channel (low, lower mid, mid, upper mid, high), now used as a reference channel. Note the best radiated EIRP value for the reference channel, i.e. EIR_{pref} . Note that the lower mid and upper mid reference channels are only applicable for certain wider frequency bands per *CTIA 01.50* [2].
3. Change the frequency of the communication tester such that it is operating on a defined intermediate channel.
4. Measure the EIRP for the intermediate channel at the location determined from the reference channel. If the EIRP measured for the intermediate channel (EIR_{IC}) is greater than or equal to ($EIR_{pref} - 2.0\text{ dB}$), then the given intermediate channel is considered a pass. Otherwise, the given intermediate channel is considered a fail.
5. Repeat steps 1 through 4 for all remaining intermediate channels. Report the free-space pass/fail status of each intermediate channel. For both the full TRP test and the intermediate channel tests, free-space testing shall be conducted based on device type, as specified in *CTIA 01.01* [6]. Perform each test on all specified frequencies with the DUT antenna extended and retracted, as applicable.
6. Repeat steps 1 through 5 for all applicable use cases for relative power on intermediate channel testing as specified in *CTIA 01.01* [6].

Section 4 Test Procedure—Receiver Performance

DUTs shall be tested in free-space and/or with phantoms as defined in *CTIA 01.72* [8] as required in *CTIA 01.01* [6] using the positioning guidelines described in *CTIA 01.71* [7] for all the test procedures mentioned in this section. The calculation of the figures of merit for receiver performance are defined in Section 3 in *CTIA 01.90* [9]

4.1 Test Procedure for TIS Test

Products supporting multiple air-interface technologies shall be tested in accordance with all relevant test procedures. Test results will be provided for each test performed in the format defined in *CTIA 01.01* [6].

Receiver sensitivity procedures will utilize the same spherical measurement procedure as specified for the transmitter power measurements in Section 3 with the exception of angular step size. Receiver performance measurements may be made simultaneously with tests performed in Section 3. For measurements not made in conjunction, test setups and frequencies designated CHn-Rx and given in the tables within *CTIA 01.50* [2], *CTIA 01.51* [3], and *CTIA 01.52* [4] should be used.

TIS shall be fully measured as described above and calculated pursuant to Section 3.3 in *CTIA 01.90* [9] for the channel(s) specified in *CTIA 01.50* [2], *CTIA 01.51* [3], and *CTIA 01.52* [4] for all frequency bands supported by the DUT and required to be tested per this test plan. All of the remaining intermediate channels must each be evaluated for relative sensitivity or fully measured TIS. In the case of fully measured TIS, the same limit as that channel's reference channel shall be applied with a 3 dB margin as per the intermediate channel test procedure. Regardless of test method, intermediate channel results shall be reported as PASS/FAIL per *CTIA 01.03* [10] Table RA.3-4. The intermediate channel test is to be performed by comparison of the fully measured channel(s) with the intermediate channels measured. Since some digital technologies have a very large number of intermediate channels, some channels may be omitted from actual testing. The combination of intermediate channels that must be evaluated will be specific to each different air interface. In the case of GNSS testing, the intermediate channels are utilized to determine if the wireless operation of the DUT interferes with the GNSS sensitivity performance of the DUT. Refer to *CTIA 01.90* [9] for details on TIS. Refer to *CTIA 01.50* [2]. For details on the intermediate channels to be tested for each air interface.

For all air interfaces and devices, TIS shall be measured with all receivers active. This measurement method and result is referred to as Combined Total Isotropic Sensitivity, or C-TIS. The C-TIS test is agnostic to whether the device under test actually has only one or multiple receivers; all that matters is that the receivers are all active during the test. The performance metrics (pass/fail criteria) are given in terms of C-TIS for all device types. Different categories of devices, having differing performance expectations based on e.g., number of receivers, may be defined, each having its own appropriate pass/fail criteria expressed in terms of C-TIS.

To accommodate the possibility that special cases may arise where an operator or manufacturer may want to measure a device with multiple receivers with measuring one receiver at a time (other receivers disabled), individually measured TIS, referred to as I-TIS, may be reported as supplemental information. I-TIS results can be mathematically combined to produce an estimated C-TIS value for a device, following the equation shown below.

Equation 4.1-1

$$\frac{1}{TIS_c} = \frac{1}{TIS_0} + \frac{1}{TIS_1}$$

This approach shall not be used for certification purposes.

For a device supporting multiple receivers, all receivers shall be enabled during the test procedure described in the remainder of this section. In this way, C-TIS is the test result, regardless whether the

device supports one or multiple receivers. In the special case that I-TIS is the desired quantity of interest, the same procedure is followed, except that all but the specified receiver-under-test on the device are disabled.

A communication tester appropriate for the air-interface is required for these tests and will be used to report the digital error rate found by the DUT. The DUT will be placed in an active call on the specified test channel(s), and in the specified test conditions. The RF power level of the communication tester will then be adjusted to achieve the desired digital error rate at each measured location on the sphere. The digital error rate from the DUT will be extracted from the communication tester or directly from the DUT, where applicable. In general, a sufficient number of bits, packets or frames will be sampled such that the confidence interval in digital error rate is 95% or better.

Typically, the maximum deviation in receive level measurements from peak to null of any one channel does not exceed 30 dB. Therefore, the test facility may elect to initiate each sensitivity measurement starting with the base station power set 30 dB above the lowest sensitivity level measured in order to reduce the time required to search for the sensitivity floor. For points where this setting is below the target sensitivity level, the sensitivity may be considered negligible for that location and the initial value used in place of an actual measurement.

The TIS measurement grid applicability, i.e., the step size taken in the theta (θ) and in the phi (ϕ) axes deemed sufficient to fully characterize the DUT 's total isotropic sensitivity is outlined in [Table 4.1-1](#). Selecting finer measurement grids is not precluded. All of the measured sensitivity values for each DUT test condition will be integrated to give a single figure of merit referred to as TIS.

Table 4.1-1: Applicability of TIS Measurement Grids

Applicability Condition	Measurement Grid Step Size $\Delta\theta$ [°]	Unique Number of Measurement Points with Constant Angular Step Size, Section 3.1.1 of CTIA 01.90 [9] $\Delta\theta = \Delta\phi$ [°]	Unique Number of Measurement Points with Theta Dependent Phi Optimization, Section 2.7 and Section 3.1.2 of CTIA 01.90 [9]
Below 3 GHz and Device Size \leq 30 cm	45	26	20
Below 3 GHz and Device Size $>$ 30 cm	30	62	46
Above 3 GHz	30	62	46

The goal of the receiver test is to measure TIS with a measurement uncertainty of no more than the values specified in [Table 5.6-1](#) with a confidence of 95%. The measurement grids listed in [Table 4.1-1](#) are not considered acceptable for accurately capturing peak field quantities at these frequencies (only integrated quantities like TIS), but that is not what is required for this test.

4.2 Test Procedure for Intermediate Channel Test

Relative sensitivity measurements or fully measured TIS will be repeated per channel on a specified list of intermediate channels as shown in [CTIA 01.50 \[2\]](#) for respective RAT.

When full TIS measurements are performed on intermediate channels, the intermediate channel passes if the full TIS result is better than 1) the TIS limit or 2) the TIS result at either of the neighboring reference channels plus 1 dB. The full TIS results at the intermediate channels may be included as additional data and marked as supplemental in the test report.

Procedure for measuring relative sensitivity on intermediate channels:

1. Set DUT as defined in *CTIA 01.50* [2] to ensure maximum output power during the test
2. Move the DUT and chamber positioner(s) to the location & polarization resulting in the best-radiated free-space sensitivity measured for the closest, in frequency, fully measured channel (low, lower mid, mid, upper mid, high), now used as a reference channel. Note that the lower mid and upper mid reference channels are only applicable for certain wider frequency bands per *CTIA 01.50* [2].
3. Note the downlink power level which corresponds to the DUT’s peak free-space radiated sensitivity as described in step 2 above, which will be referred to as $FS\ EIS_{(peak\ low)}$. Next, determine the margin, $M1_{low}$, in dB, between the DUT’s measured TIS and the corresponding TIS limit in *CTIA 01.01* [6] Section 3. If the device doesn’t meet the required TIS limit, then set $M1_{low} = 0$. Adjust the digital call simulator to the RF power level calculated by the following formula:

Equation 4.2-1

$$Downlink\ Signal\ Power_{low}\ (dBm) = FS\ EIS_{(peak\ low)}\ (dBm) + M1_{low}\ (dB) + 3\ (dB)$$

For example, if the DUT’s $FS\ EIS_{(peak\ low)}$ was -108 dBm on the low-frequency reference channel, the DUT’s low-frequency reference channel $FS\ TIS_{low}$ was -104 dBm, and the FS TIS limit is -100 dBm, we have:

$$(-108\ (dBm) + 4\ (dB) + 3\ (dB))\ dBm = -101\ dBm$$

In this example, the signal generator would be set to -101 dBm for all intermediate channels associated with the low-frequency reference channel. Similar evaluations are performed for lower mid, mid, upper mid, and high reference channels. Note that $M1_{low}$, $M1_{lower\ mid}$, $M1_{mid}$, $M1_{upper\ mid}$, and $M1_{high}$ can vary depending on how much the FS TIS of each channel exceeds the FS TIS limit.

4. Without changing the RF signal level at the DUT, change the frequency of the communication tester such that it is operating on a defined intermediate channel.
5. Determine pass/fail according to the threshold defined in *CTIA 01.50* [2].

RAT	Sensitivity Threshold	Duration
GSM	Class II RBER 2.44%	95% confidence or 135 frames
GPRS	BLER 10%	95% confidence or 2000 blocks
EGPRS	BLER 10%	95% confidence or 2000 blocks
UMTS (WCDMA)	BER 1.2%	95% confidence or 20000 bits
LTE, NR FR1	95% max throughput	95% confidence

6. Repeat steps 4 through 5 of this procedure for all remaining intermediate channels listed in *CTIA 01.50* [2]. If the reference channel changes, move to the location and polarization of the next reference channel, see step 2, and take the DUT’s measured FS TIS and BHHR TIS on the low, lower mid, mid, upper mid, and high-frequency reference channels into account when calculating the downlink signal power level according to [Equation 4.2-1](#) in step 3.

7. Report the free-space pass/fail status of each intermediate channel listed in *CTIA 01.50* [2]. For both the full TIS test and the intermediate channel tests, free-space testing shall be conducted based on device type, as specified in *CTIA 01.01* [6]. Perform each test on all specified frequencies with the DUT antenna extended and retracted, as applicable.
8. If the device must be tested in the BHHR position, then move the DUT and chamber positioner(s) to the location and polarization resulting in the best-radiated BHHR sensitivity measured for the closest, in frequency, fully measured channel (low, lower mid, mid, upper mid, high), now used as a Reference Channel. Note that the lower mid and upper mid reference channels are only applicable for certain wider frequency bands per *CTIA 01.50* [2].
9. Devices which must be tested in the BHHR position shall be evaluated for intermediate channel performance using a Pass/Fail limit provided by the following formula:

Equation 4.2-2

$$BHHR\ TIS\ Pass/Fail\ limit_{low}\ (dBm) = FS\ TIS\ Pass/Fail\ limit\ (dBm) + (DUT\ BHHR\ TIS_{low}\ (dBm) - DUT\ FS\ TIS_{low}\ (dBm))$$

For example, if the FS TIS limit is -100 dBm, the DUT BHHR TIS_{low} on the low-frequency reference channel is -99 dBm, and the DUT FS TIS_{low} on the low-frequency reference channel is -104 dBm, we have:

$$(-100\ (dBm) + (-99\ (dBm) - (-104\ (dBm))))\ dBm = -95\ dBm$$

In this example, -95 dBm would be the BHHR $TIS\ Pass/Fail\ Limit_{low}$ used when repeating steps 2 through 7 above with the DUT in the BHHR position for all intermediate channels associated with the low-frequency reference channel.

Similar evaluations are performed for lower mid, mid, upper mid, and high reference channels. Note that $BHHR\ TIS\ Pass/Fail\ limit_{low}$, $BHHR\ TIS\ Pass/Fail\ limit_{lower\ mid}$, $BHHR\ TIS\ Pass/Fail\ limit_{mid}$, $BHHR\ TIS\ Pass/Fail\ limit_{upper\ mid}$, and $BHHR\ TIS\ Pass/Fail\ limit_{high}$ can be different.

10. Note the downlink power level which corresponds to the DUT's peak BHHR radiated sensitivity as described in step 8 above, which will be referred to as BHHR $EIS_{(peak\ low)}$. Since the BHHR $TIS\ Pass/Fail\ limit_{low}$ is directly derived from the FS limit and the TIS difference, see Equation 4.2-2, the same margin $M1_{low}$ is to be used. Adjust the digital call simulator to the RF power level calculated by the following formula:

Equation 4.2-3

$$Downlink\ Signal\ Power_{low}\ (dBm) = BHHR\ EIS_{(peak\ low)}\ (dBm) + M1_{low}\ (dB) + 3\ (dB)$$

For example, if the DUT's BHHR $EIS_{(peak\ low)}$ was -100 dBm on the low-frequency reference channel, the DUT's low-frequency reference channel $BHHR\ TIS_{low}$ was -96 dBm, and the $BHHR\ TIS_{low\ limit}$ is -92 dBm, we have:

$$(-100\ (dBm) + 4\ (dB) + 3\ (dB))\ dBm = -93\ dBm$$

In this example, the signal generator would be set to -93 dBm for all intermediate channels associated with the low-frequency reference channel. Similar evaluations are performed for mid and high reference channels.

11. Without changing the RF signal level, change the frequency of the communication tester such that it is operating on a defined intermediate channel.
12. Determine pass/fail according to the threshold defined in step 5.
13. Repeat steps 11 through 12 of this procedure for all remaining intermediate channels. If the reference channel changes, move to the location and polarization of the next reference channel, see step 8, and take the DUT's measured FS TIS and BHR TIS on the low, lower mid, mid, upper mid, and high-frequency reference channels into account when calculating the downlink signal power level according to [Equation 4.2-3](#) in step 10.
14. Report the BHR pass/fail status of each intermediate channel listed in [CTIA 01.50 \[2\]](#). For both the full TIS test and the intermediate channel tests, head/hand testing shall be conducted based on device type, as specified in [CTIA 01.01 \[6\]](#). Refer to [CTIA 01.72 \[8\]](#) for head/hand testing requirements. Perform each test on all specified frequencies with the DUT antenna extended and retracted, as applicable.
15. The methodology in step 9 shall be applied to determine the TIS Pass/Fail Limits for all non-primary mechanical modes, if applicable, for the purpose of performing the intermediate channel desensitization test.

[Figure 4.2-1](#) is an illustration of relative sensitivity on intermediate channels test. The green lines indicate a pass-fail test performed (margin + 3) dB above the corresponding EIS level of the nearest channel for which a full TIS measurement was performed.

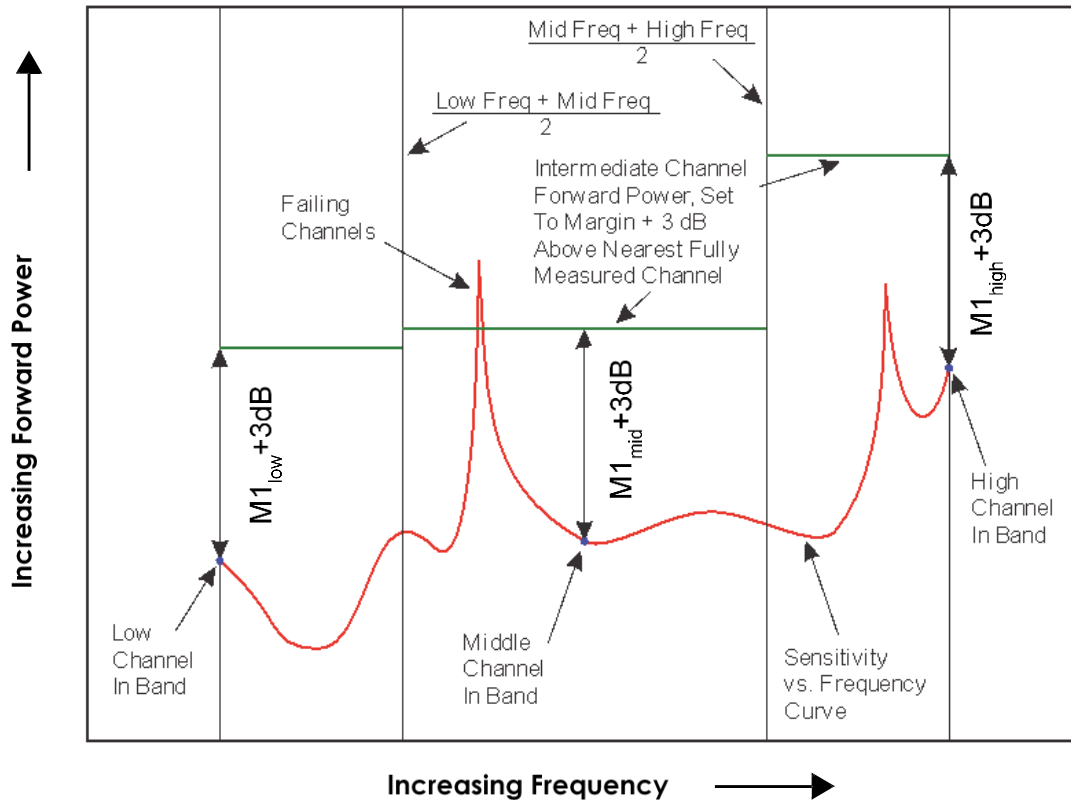

Figure 4.2-1 Illustration Of Relative Sensitivity On Intermediate Channels Test

For the intermediate channel tests, head and hand phantom and free-space test configurations shall be conducted based on device type, as specified in *CTIA 01.01* [6]. Refer to *CTIA 01.72* [8] for head/hand testing requirements. Perform each test on all specified frequencies with the DUT antenna extended and retracted, as applicable.

4.3 LAA Un-Licensed Degradation (LUD) Test

For the LAA un-licensed degradation test, the Band 46 reference TIS is defined as follows:

- For $FS\ TIS_{ref}$, -83 dBm, assuming the -90 dBm conducted REFSENS value in *3GPP TS 36.101* [15] and an antenna efficiency of -7 dB.
- For $HR/HL\ TIS_{ref}$, -80 dBm, assuming the -90 dBm conducted REFSENS value in *3GPP TS 36.101* [15] and an antenna efficiency of -10 dB.

Procedure for evaluating Band 46 radiated sensitivity using the LAA un-licensed degradation test for a given LAA CA combination:

1. Move the DUT and chamber positioner(s) to the location & polarization resulting in the best-radiated free-space sensitivity measured for the full Band 46 TIS test for the low Band 46 test frequency, now used as a Reference Channel. Set the PCC to the corresponding channel settings in Table 4.4-1 and Table 4.4-2 of *CTIA 01.50* [2] for the case where the Band 46 SCC is set to the low Band 46 test frequency for the LAA CA combination under test.
2. Note the downlink power level which corresponds to the DUT's peak free-space radiated sensitivity as described in Step 1 above, which will be referred to as $FS\ EIS_{peak\ ref\ low}$. Next, determine the margin, $M1_{low}$, in dB, between the DUT's measured TIS (for the full Band 46 TIS

test) and the corresponding $FS\ TIS_{ref}$. If the device doesn't meet the $FS\ TIS_{ref}$ (for the full Band 46 TIS test), then set $M1_{low} = 0$. Adjust the digital call simulator to the RF power level calculated by the following formula:

$$FS\ Downlink\ Signal\ Power_{low}\ (dBm) = FS\ EIS_{(peak\ ref\ low)}\ (dBm) + M1_{low}\ (dB) + 3\ (dB)$$

For example, if the DUT's $FS\ EIS_{(peak\ ref\ low)}$ was -106 dBm on the reference channel and the FS TIS (for the full Band 46 TIS test on the reference channel) was -85 dBm, we have:

$$(-106\ (dBm) + 2\ (dB) + 3\ (dB))\ dBm = -101\ dBm$$

In this example, the signal generator would be set to -101 dBm for the low test channel for all LAA CA combinations in Table 4.4-1 and 4.4-2 of *CTIA 01.50* [2] that are tested in free space using the LAA Un-Licensed Degradation Test.

3. Throughput of the DUT shall be measured using the test procedure in Section 7.3A.3 of *3GPP TS 36.521-1* [11] using the downlink and uplink reference measurement channels defined in Annexes A.2.2, A.2.3, and A.3.2 of *3GPP TS 36.521-1* [11] and Table 4.4-1 and Table 4.4-2 of *CTIA 01.50* [2] (the data throughput rate is as defined in Section 7.3A.3 of *3GPP TS 36.521-1* [11]). For LTE Band 13, the settings in Table 4.1-3 of *CTIA 01.50* [2] shall take precedence over the settings in Annexes A.2.2, A.2.3, and A.3.2 of *3GPP TS 36.521-1* [11]. The LTE communication tester shall send continuous uplink power control "up" commands to the DUT to ensure the DUT's transmitter is at maximum output power. The measured throughput rate shall be greater than or equal to 95% of the maximum throughput of the reference measurement channel. Care must be taken to ensure that the duration of the throughput measurement is sufficient to achieve statistical significance according to Annex G.2 of *3GPP TS 36.521-1* [11]. If the throughput test fails, increase FS Downlink Signal Power low in 1 dB steps until the throughput test passes.
4. Repeat steps 1 through 3 of this procedure for the mid and high test channels per Table 4.4-1 and Table 4.4-2 of *CTIA 01.50* [2].
5. Report the free-space pass/fail status of each test channel for the LAA CA combination under test. For test channels which failed, report the value of FS Downlink Signal Power required to pass the test. Free-space testing shall be conducted based on device type, as specified in *CTIA 01.01* [6]. Perform each test on all specified frequencies with the DUT antenna extended and retracted, as applicable.
6. If the device must be tested in the HR and HL positions, then move the DUT and chamber positioner(s) to the location & polarization resulting in the best-radiated HR sensitivity measured for the full Band 46 TIS test for the low Band 46 test frequency, now used as a Reference Channel. Set the PCC to the corresponding channel settings in Table 4.4-1 and Table 4.4-2 of *CTIA 01.50* [2] for the case where the Band 46 SCC is set to the low Band 46 test frequency for the LAA CA combination under test.
7. Note the downlink power level which corresponds to the DUT's peak HR radiated sensitivity as described in Step 6 above, which will be referred to as $HR\ EIS_{(peak\ ref\ low)}$. Next, determine the margin, $M1_{low}$, in dB, between the DUT's measured TIS (for the full Band 46 TIS test) and the corresponding $HR\ TIS_{ref}$. If the device doesn't meet the $HR\ TIS_{ref}$ (for the full Band 46 TIS test), then set $M1_{low} = 0$. Adjust the digital call simulator to the RF power level calculated by the following formula:

$$HR\ Downlink\ Signal\ Power_{low}\ (dBm) = HR\ EIS_{(peak\ ref\ low)}\ (dBm) + M1_{low}\ (dB) + 3\ (dB)$$

For example, if the DUT's $HR\ EIS_{(peak\ ref\ low)}$ was -98 dBm on the reference channel and the $HR\ TIS$ (for the full Band 46 TIS test on the reference channel) was -82 dBm, we have:

$$(-98 \text{ (dBm)} + 2 \text{ (dB)} + 3 \text{ (dB)}) \text{ dBm} = -93 \text{ dBm}$$

In this example, the signal generator would be set to -93 dBm for the low channel for all LAA CA combinations in Table 4.4-1 and Table 4.4-2 of *CTIA 01.50* [2] that are tested with HR using the LAA Un-Licensed Degradation Test.

8. Throughput of the DUT shall be measured using the test procedure in Section 7.3A.3 of *3GPP TS 36.521-1* [11] using the downlink and uplink reference measurement channels defined in Annexes A.2.2, A.2.3, and A.3.2 of *3GPP TS 36.521-1* [11] and Table 4.4-1 and Table 4.4-2 of *CTIA 01.50* [2] (the data throughput rate is as defined in Section 7.3A.3 of *3GPP TS 36.521-1* [11]). For LTE Band 13, the settings in Table 4.1-3 of *CTIA 01.50* [2] shall take precedence over the settings in Annexes A.2.2, A.2.3, and A.3.2 of *3GPP TS 36.521-1* [11]. The LTE communication tester shall send continuous uplink power control “up” commands to the DUT to ensure the DUT’s transmitter is at maximum output power. The measured throughput rate shall be greater than or equal to 95% of the maximum throughput of the reference measurement channel. Care must be taken to ensure that the duration of the throughput measurement is sufficient to achieve statistical significance according to Annex G.2 of *3GPP TS 36.521-1* [11]. If the throughput test fails, increase HR Downlink Signal Power low in 1 dB steps until the throughput test passes.
9. Repeat steps 1 through 3 of this procedure for the mid and high test channels per Table 4.4-1 and Table 4.4-2 of *CTIA 01.50* [2].
10. Report the HR pass/fail status of each test channel for the LAA CA combination under test. For test channels which failed, report the value of HR Downlink Signal Power required to pass the test. HR testing shall be conducted based on device type, as specified in *CTIA 01.01* [6]. Perform each test on all specified frequencies with the DUT antenna extended and retracted, as applicable.
11. Repeat steps 6 through 10 for the HL position.
12. Repeat steps 1 through 11 for all LAA CA combinations where Band 46 sensitivity will be evaluated using the LAA Un-Licensed Degradation Test.

For the LAA un-licensed degradation test, hand phantom only and/or free-space testing shall be conducted based on device type, as specified in *CTIA 01.01* [6]. Refer to *CTIA 01.72* [8] for hand testing requirements. Perform each test on all supported CA modes defined in Table 4.4-1 and Table 4.4-2 of *CTIA 01.50* [2] according to the use cases associated with each band as specified in Table 4.4-1 and Table 4.4-2 of *CTIA 01.50* [2] with the DUT antenna extended and retracted, as applicable.

Hand phantoms meeting the CTIA specifications in *CTIA 01.72* [8] up to 3 GHz shall be used for Band 46 testing.

Following alternate test procedures may significantly reduce the test time for TIS. Use of these alternate test methods may require additional measurement uncertainty calculations, which are discussed in Section 5.5.

4.4 Single Point Offset Test

This offset test procedure significantly reduces the test time for TIS for multi-protocol phones, which have more than one protocol in the same frequency band. This offset test procedure can be used to determine the offset in TIS between different protocols on equivalent channels, as well as between different error rates and/or data rates using the same protocol on the same channel. “Equivalent channels” assumes that the two channels are close enough in frequency that the pattern does not change. A single point offset test or a multi-point offset test may be used. This method may be used between stand-alone LTE and LTE CA or one LTE CA combination and another, when the same band, channel and RB allocation

combination is evaluated in both LTE combinations if single point offset testing is allowed for the CA combination as specified in the operator CA combination priority list identified in *CTIA 01.01* [6].

This offset test procedure for TIS cannot be used with an antenna which uses a different physical radiator, or different aperture tuning (e.g. matching on parasitic elements or matching components on the ground or within the radiator) between the reference protocol and the protocol being evaluated. This offset test procedure cannot be used in this case because the antenna pattern will generally be different between the 2 protocols.

This offset test procedure for TIS can be used with an antenna which uses the same physical radiator, the same aperture tuning (e.g. matching on parasitic elements or matching components on the ground or within the radiator) but uses different impedance matching (e.g. matching components on the RF feed) between the reference protocol and the protocol being evaluated,

The manufacturer must declare to the ATL when antennas are implemented in such a way that this offset test procedure for TIS cannot be used, when single point offset tests are considered.

This offset test procedure also can be used only for protocols that utilize the same antenna combinations, for example, both protocols employ 2-branch diversity and the same pair of antennas. In this way, the C-TIS measured for one protocol can appropriately be scaled by the single point measurement for the other protocol.

It is recommended that voice digital protocols be given priority when doing full TIS measurements. For purposes of clarity for the following test procedure, test configuration A will be protocol/error rate/data rate for which a full TIS measurement is performed. Test configuration B will be the other protocol/error rate/data rate which will be tested using the single/multi-point radiated test.

This test sequence is repeated for each channel specified in the appropriate part of *CTIA 01.50* [2]. This test sequence shall be repeated for each DUT antenna configuration (free space, head and hand phantom, hand phantom only, whip extended, whip retracted). The single point radiated sensitivity for both test configurations, the difference, and the calculated TIS for test configuration B shall be recorded.

The TIS test for test configuration A shall be completed first according to the appropriate part of *CTIA 01.50* [2] after identifying the position and polarization for which the DUT has its maximum radiated sensitivity for one channel, the DUT should be placed in the same configuration. A radiated sensitivity measurement shall be first performed in test configuration A according to the relevant procedures in *CTIA 01.50* [2]. If possible, without touching the phone, initiate a hand-off or change to test configuration B at the equivalent channel. Otherwise, initiate a call in test configuration B and go to the equivalent channel. If the phone must be handled in order to initiate a call in test configuration B, then an additional repositioning uncertainty must be included to account for positioning repeatability. Following that, a radiated sensitivity measurement shall be performed in test configuration B according to the relevant procedures in *CTIA 01.50* [2]. The two measurements shall be conducted as close in time as possible. The difference between these radiated tests shall then be used as an offset to the TIS for test configuration A in order to calculate the TIS for test configuration B.

4.5 Multi-point Offset Test

This offset method has similar benefits as the Single-Point Offset Test in Section 4 and has the same restrictions as discussed in Section 4.3.

Multiple positions and polarizations shall be predetermined for comparing test configurations A and B. The test positions and polarizations shall be selected such that they are spread relatively evenly in time throughout the TIS test and are spread relatively evenly in space over the sphere. While the TIS test for test configuration A is being performed, measurements for test configuration B will be performed at those predetermined positions and polarizations.

This is accomplished at those predetermined positions and polarizations by:

1. Measuring the radiated sensitivity for test configuration A,
2. Handing-off or changing to test configuration B,
3. Measuring the radiated sensitivity for test configuration B,
4. Handing-off or changing to test configuration A,
5. Continuing the TIS test until another predetermined position and polarization is to be tested, at which time, steps 1 to 5 are repeated.

The difference between the averages of the radiated sensitivities at the predetermined positions and polarizations shall then be used as an offset to the TIS for test configuration A in order to calculate the TIS for test configuration B.

Note: *More than 4 test positions/polarizations are recommended to keep the measurement uncertainty low.*

Note: *This test procedure using multiple test positions/polarizations will have lower uncertainty than the test procedure using a single test position/polarization.*

Note: *Using higher error rates and higher data rates can result in significantly faster test times for TIS.*

4.6 Alternate Test Procedure for GSM TIS Using Less Than Maximum TX Power

This alternate test procedure is specifically to allow the radiated RX sensitivity testing for the 3D pattern for the GSM protocol to be performed at low TX power levels. The purpose of this allowance is to enable the battery to last longer during testing, which in turn enables more automated testing without having to change the battery. In particular, more testing can be accomplished unattended over night.

The same low TX power must be used during the entire TIS measurement. The next step involves using something similar to the single-point offset test procedure for TIS (in Section 4.3)

After identifying the position and polarization for which the DUT has its maximum radiated sensitivity for one channel, the DUT shall be placed in the same configuration. A radiated sensitivity measurement shall be first performed using low TX power according to the relevant procedures in CTIA 01.50 [2]. Without touching the phone, change the TX power to maximum. Then a radiated sensitivity measurement shall be performed using maximum TX power according to the relevant procedures in CTIA 01.50 [2]. The two measurements shall be conducted as close in time as possible. The difference between these radiated tests shall then be used as an offset to the TIS using low TX power in order to calculate the TIS with maximum TX power. This test sequence is repeated for each channel specified in the appropriate part of CTIA 01.50 [2]. This test sequence shall be repeated for each DUT antenna configuration (free space, head and hand phantom, hand phantom only, whip extended, whip retracted). The single point radiated sensitivity at low and maximum TX power, the difference, and the calculated TIS using maximum TX power shall be recorded.

The additional uncertainty associated with the single point test would need to be included, as discussed in Section 5.5.

Note: *Intermediate channel testing shall be performed using maximum TX power.*

4.7 Alternate TIS Test Procedure based on Receive Signal Strength (RSS)

This procedure details the methodology to be used when determining TIS using receive signal strength measurements. The test methodology will consist of four steps; RSS Pattern Measurement, RSS Pattern Linearization, Sensitivity Search, and Final TIS Calculation. The receive signal strength measurements that are available for any particular technology can vary. These may take the form of the following; RSSI

(Receive Signal Strength Indicator), Carrier to Noise, Signal to Noise, Carrier to Interference, indicators based on code phase RMS error estimates, etc.

The Alternate TIS Test Procedure based on Receive Signal Strength shall not be used for cellular radio mode TIS testing for 3GPP protocols that require the use of more than one receive antenna and for any cellular radio modes supported by the DUT that use more than one receive antenna.

4.7.1 RSS Pattern Measurement

The RSS Pattern Measurement shall utilize the same spherical measurement procedure as specified in [Table 5.6-1](#). A receive signal strength measurement shall be made at each polarization and point on the sphere. For MBS where the received signal strength measurement is derived from the code phase RMS error, RSS is based on the estimated peak SNR at the UE, and computed from the code phase RMS error reported by the UE using the conversion in *CTIA 01.51 [3]* Section 2. The dynamic range of the RSS measurement shall be at least 20 dB and the minimum RSS measurement level shall be at least 10 dB above the noise floor of the measurement capability. If the RSS measurement for a particular polarization or point is below the dynamic range of the measurement capability or cannot be obtained, the data point shall be recorded with a value that is at least 20 dB below the lowest RSS measurement.

This receive signal strength measurement may be obtained in a number of different methods. The DUT may report the value via over-the-air messaging if the technology supports this mechanism. The DUT may record the values in non-volatile memory or RAM using an on-board application or test mode. The stored results would be extracted from the device via a data cable or via an over-the-air data connection supported by the DUT. If the results are extracted from the DUT after the test, there shall be a mechanism to reconcile the data with each position. Each measurement point shall be sufficiently averaged to reduce uncertainty to the value defined in the uncertainty budget.

It is recommended that the RSS pattern measurement be performed by reporting the RSS measurement via over-the-air messaging if the communication tester for the technology supports that mechanism. It is also recommended that the RSS measurements be made with the transmitter enabled via normal call processing, a special test mode, or an on-board application if the technology being tested normally supports the use of a reverse link.

4.7.2 RSS Pattern Linearization

The RSS pattern measurements shall be linearized. The peak in the RSS pattern shall be determined from the data collected in [Section 4.7.1](#). Re-position the DUT to the location of the maximum RSS. For GNSS, the chosen peak shall be in the upper hemisphere. As an alternative, the RSS linearization data may be obtained using a conducted test setup but the additional uncertainty shall be accounted for in the uncertainty budget.

Receive signal strength measurements shall be made at a maximum of 1 dB steps from the peak RSS measurement to at least 10 dB below the peak RSS measurement made in [Section 4.7.1](#). Care should be taken to avoid compression of the receiver or highly non-linear regions outside of the minimum linearization range specified above. These RSS measurements along with the corresponding signal level presented to the DUT shall be used to linearize the pattern data collected in [Section 4.7.1](#) such that the pattern data corresponds to a dB for dB change in the signal level presented to the DUT. RSS data that falls within the utilized step size shall be linearly interpolated. The interpolation shall be done in dB as opposed to in linear units. The linearization may be accomplished through various methods (see *CTIA 01.90 [9]*) such as, but not limited to, Best Fit Straight Line methods or piecewise linear methods, as long as the proper linearization uncertainty has been accounted for in the uncertainty budget. RSS data that falls outside of the data set that was used to determine the linearization data shall be linearized to a line that is extended using the same slope as determined above for the last set of data points used for linearization at the edge of the dataset.

This receive signal strength measurement may be obtained in a number of different methods. The DUT may report the value via over-the-air messaging if the technology supports this mechanism. The DUT may record the values in non-volatile memory or RAM using an on-board application or test mode. The stored results would be extracted from the device via a data cable or via an over-the-air data connection supported by the DUT. In either case, the method used shall be the same method that was used for the RSS Pattern Measurement. Each measurement point shall be sufficiently averaged to reduce uncertainty to the value defined in the uncertainty budget.

It is recommended that the RSS pattern measurement be performed by reporting the RSS measurement via over-the-air messaging if the communication tester for the technology supports that mechanism. It is also recommended that the RSS measurements be made with the transmitter enabled via normal call processing, a special test mode, or an on-board application if the technology being tested normally supports the use of a reverse link. In either case, the method used shall be the same method that was used for the RSS Pattern Measurement.

4.7.3 Sensitivity Search

The peak in the RSS pattern shall be determined from the data collected in Section 4.7.1. Re-position the DUT to the location of the maximum RSS. For GNSS, the chosen peak shall be in the upper hemisphere. Care should be taken not to disturb the DUT between the RSS Pattern Linearization step and this step. If the DUT is disturbed or repositioned, an appropriate repositioning uncertainty contribution shall be taken. If the RSS linearization data was obtained via conducted test methods, the additional repositioning uncertainty contribution has already been taken in Section 4.7.2. For all cases, a repositioning uncertainty shall be taken due to the repositioning of the DUT after the pattern measurement in Section 4.7.1. Perform a single-point sensitivity measurement for the particular technology in accordance with the measurement methodology specified for that technology.

The single-point sensitivity measurement may be obtained in a number of different methods. The sensitivity measurement may be performed via over-the-air messaging if the technology supports this mechanism. The DUT may record the error rates versus signal level in non-volatile memory or RAM using an on-board application or test mode. The stored results would be extracted from the device via a data cable or via an over-the-air data connection supported by the DUT.

If the technology being tested supports an EIS measurement via over-the-air messaging, the EIS measurement shall be made in this configuration with the transmitter set to maximum output power. If the technology being tested normally uses a reverse link to communicate to a server, the EIS measurement shall be made with the reverse link transmitter at maximum output power and enabled via normal call processing, a special test mode, or an on-board application.

The conducted sensitivity of the DUT shall also be measured at the antenna connector, if available, on all applicable protocols/frequencies. It is preferable that the DUT be the same as utilized for the RSS measurements. However, if the DUT does not readily support an antenna port for conducted measurements, a separate modified DUT may be provided for all conducted measurements. If no connector is available, the conducted sensitivity measurement is not required. Ideally, the sensitivity measurement will be performed with the same instrumentation in an equivalent configuration in order to minimize the measurement uncertainty involved. A different sensitivity measurement device may be used as long as any differences in absolute measurement accuracy are accounted for, either in corrections to the recorded sensitivity level or increased reported measurement uncertainty for the conducted measurement. Refer to Section 6.2 for more information on conducted sensitivity measurements and cabling setups.

4.7.4 RSS Data Format

This section specifies the format for DUT-generated RSS data used in the TIS pattern measurement process and other RSS-based tests under development. The DUT shall generate data in the specified format, either directly or via an intermediate data parser.

4.7.4.1 RSS Data Stored Locally on DUT

RSS data stored locally on the DUT during the pattern measurement process shall take the form of a comma-delimited ASCII text file. Each row or line of the file shall contain a single time stamped RSS measurement record. Each record shall terminate with a Carriage Return (decimal ASCII code 13) or Carriage Return/Line Feed combination (decimal ASCII codes 13+10).

Each measurement record or file line shall contain 6 fields as specified below separated by commas:

- **Date:** YYYY-MM-DD (e.g. “2008-03-15”)
- **Time:** HH:MM:SS.000 (e.g. “16:20:01.568”). 24-hour format. The number of decimal points for fractional seconds shall depend on the available time resolution of the DUT’s underlying technology.
- **Signal Source:** Integer index indicating the signal source for air interfaces using multiple signal sources, e.g., multiple satellite GPS L1 scenarios or multiple MBS beacon scenarios. In cases where signal sources have standard numerical identifiers, such as GPS L1 satellite IDs or MBS transmitter ID, this field shall contain that identifier. Otherwise, this field shall index starting from 0.
- **Antenna:** Integer index, starting from 0, indicating the antenna or receive chain for DUTs supporting multiple receivers. This value shall always be “0” for single-antenna devices.
- **RSS:** Received Signal Strength value (power in dBm; ratios in dB). For MBS, RSS is derived from the code phase RMS error as defined in in *CTIA 01.51* [3] Section 2.
- **Phase:** Phase angle of received signal in radians. For dual receiver LTE devices, this may be the relative phase between the two receivers. This value shall always be “0” if no phase information is provided.

The date and time fields must represent accurate elapsed time over the data collection period, but they are not required to be synchronized to a specific time-of-day reference. However, if these time stamps are not explicitly synchronized to the time reference used by the range equipment, the test solution developer must provide a mechanism to account for the time offset between DUT data and any range-specific data (e.g. position) collected simultaneously.

The first example below shows a data segment for a single-antenna device generating no phase information, with a single signal source. The second example shows a data segment for a dual-antenna device generating phase information, with a single signal source.

Example RSS Data Segment for a Single-antenna Device Providing No Phase Information, with One Signal Source

```
2008-03-15,16:20:01.568,0,0,-83.22,0
2008-03-15,16:20:01.771,0,0,-83.17,0
2008-03-15,16:20:01.964,0,0,-82.89,0
2008-03-15,16:20:02.167,0,0,-82.83,0
```

Example RSS Data Segment for a Dual-antenna Device Providing Phase Information, with One Signal Source

```
2008-03-15,16:20:01.568,0,0,-83.22,1.22972
2008-03-15,16:20:01.771,0,1,-88.83,2.54263
2008-03-15,16:20:01.964,0,0,-82.89,1.26694
2008-03-15,16:20:02.167,0,1,-89.41,2.52346
```

4.7.4.2 RSS Data Reported via Over-The-Air Messaging

In the case where RSS data are reported via over-the-air messaging, data records shall be generated in a format identical to single lines of the data file format specified in Section 4.7.4.1. Alternatively, the data may be transmitted by the DUT in a native format and converted to the specified format upon receipt by a data parsing application.

4.7.5 Error Rate Data Format

This section specifies the format for DUT-generated error rate data used in the sensitivity search process. The DUT shall generate data in the specified format, either directly or via an intermediate data parser. This format is not applicable for the current A-GNSS sensitivity search methodologies defined in *CTIA 01.51* [3].

4.7.5.1 Error Rate Data Stored Locally on DUT

Error rate data stored locally on the DUT during the sensitivity search process shall take the form of a comma-delimited ASCII text file. Each row or line of the file shall contain a single time stamped measurement record. Each record shall terminate with a Carriage Return (decimal ASCII code 13) or Carriage Return / Line Feed combination (decimal ASCII codes 13+10).

Each measurement record or file line shall contain 4 fields as specified below separated by commas:

- **Date:** YYYY-MM-DD (e.g. “2008-03-15”)
- **Time:** HH:MM:SS.000 (e.g. “16:20:01.568”). 24-hour format. The number of decimal points for fractional seconds shall depend on the available time resolution of the DUT’s underlying technology.
- **Errors:** Number of errors (bits, frames, packets, blocks, etc., depending on technology) or acquisition failure count for sensitivity definitions based on probability of acquisition.
- **Total:** Total observed number of bits, frames, packets, blocks, etc. or acquisition attempt count for sensitivity definitions based on probability of acquisition.

The date and time fields must represent accurate elapsed time over the data collection period, but they are not required to be synchronized to a specific time-of-day reference. However, if these time stamps are not explicitly synchronized to the time reference used by the range equipment, the test solution developer must provide a mechanism to account for the time offset between DUT data and any range-specific data (e.g., downlink power) collected simultaneously.

The example below shows an error rate data segment illustrating a hypothetical sensitivity search. Although not required, error rate data are typically reported at a fixed interval representing a fixed number of bits, frames, packets, acquisition attempts, etc.

Example Error Rate Data Segment

```
2008-03-15,21:40:01.568,0,602
2008-03-15,21:40:02.571,0,602
2008-03-15,21:40:03.564,0,602
2008-03-15,21:40:04.567,0,602
2008-03-15,21:40:05.562,1,602
2008-03-15,21:40:06.566,4,602
2008-03-15,21:40:07.570,17,602
...
```

4.7.5.2 Error Rate Data Reported via Over-The-Air Messaging

In the case where error rate data are reported via over-the-air messaging, data records shall be generated in a format identical to single lines of the data file format specified in Section 4.7.5.1. Alternatively, the data may be transmitted by the DUT in a native format and converted to the specified format upon receipt by a data parsing application.

4.7.6 Final TIS Calculation

The final TIS and other spatially averaged quantities shall be calculated per Section 3 in *CTIA 01.90* [9]. In all cases, the linearized RSS values shall be used in the calculations.

4.8 TIS Measurement of Low Transmit Duty-Cycle Devices

An underlying assumption in the TIS test methodologies described in *CTIA 01.50* [2], and of this document is that the DUT is capable of supporting a moderate to high transmit duty-cycle during normal operation. However, some DUTs are designed to transmit at full power for only a fraction of each hour, and as a result, typically have a very small heatsink for the power amplifier and a relatively low-capacity battery. Attempts to measure TIS using the current CTIA methodology will, in many cases, cause the DUT to be damaged due to excessive heat.

This TIS test methodology described below applies only to DUTs which have insufficient power/thermal capacity to maintain the cellular link for at least 50% of the execution time of a single channel TRP or TIS test. It applies regardless of cellular radio mode, so it may be utilized, as applicable, for any DUT which would otherwise be tested according to *CTIA 01.50* [2].

1. If the DUT supports multiple cellular radio modes, determine which cellular radio mode includes the highest number of CTIA normative bands. If more than one cellular radio mode supports the same number of bands, the highest-order supported cellular radio mode (e.g. LTE > UMTS) shall be selected to begin this test procedure.
2. Configure the network simulator so that the DUT output power will be approximately 10 dB below full output power. It's not necessary to set the uplink power to exactly 10 dB below full-power, it's only necessary to ensure that the DUT's uplink power setting on the network

simulator is known and maintained through the execution of all subsequent tests, except as noted. The recommended device warm up time described in Clause 5 of this document should be applied to the reduced output power.

3. With the network simulator set to command the DUT to operate at a reduced output power, execute the TIS measurement process following the CTIA procedure for the airlink under test in the selected band. This TIS is called *TIS_{protocol tested with reduced power}*.
4. Once radiated sensitivity data from all measurement points have been collected for the selected band, determine the peaks in the DUT pattern and orient the measurement antenna(s) to the peak associated with the low-frequency reference channel.
5. With the measurement antennas at the antenna pattern peak as described in Step 4, obtain a single radiated sensitivity (EIS) measurement on the band's first reference channel with reduced power (*EIS_{red.power}*). Document the radiated sensitivity at this measurement location for reduced power.
6. Command the DUT to transmit at full power only long enough to obtain a single radiated sensitivity measurement on the selected band's first reference channel. Document the radiated sensitivity at this measurement location for full power (*EIS_{full power}*).
7. Repeat Step 5, 6 for all other cellular radio modes supported by the DUT in this band and which are required to be tested.
8. Repeat Steps 3 through 7 for the remaining two reference channels using the measurement antenna locations corresponding to the peak in the DUT's antenna pattern at each reference frequency determined earlier.
9. If any subsequent cellular radio modes include bands not tested in Steps 2 through 8, follow a similar TIS measurement methodology for the previously-untested band(s) or cellular radio mode(s).
10. Once all EIS measurement data have been obtained, compare the EIS at the peak of the antenna pattern while operating at full power (*EIS_{full power protocol X}*) in each of the reference channels to the sensitivity measured at these measurement antenna positions (corresponding to the peak in the DUT's pattern) at reduced power (*EIS_{red.power protocol X}*). Document the reduction in radiated sensitivity (if any, in dB) between full and reduced power.
11. Calculate TIS for the DUT in the following way for all protocols and reference channels.

$$TIS_{protocol X} = TIS_{protocol tested with reduced power} + EIS_{full power protocol X} - EIS_{protocol tested with red.power}$$

Only one protocol is tested for TIS with reduced power per band. The TIS for all other protocols is determined using the above equation.

12. Intermediate-channel receiver sensitivity measurements shall be executed at full power using the methodology currently specified in Section 4.2. If the number of intermediate channels is high, it may be necessary to allow the DUT to cool between measurements.

4.9 Testing of Cellular Desensitization due to Simultaneous Operation of 802.11 Radios for Integrated Devices

4.9.1 Testing Overview

The cellular desensitization test consists of repeating the relative sensitivity on intermediate channels test in the presence of the 802.11 uplink interferer for each cellular radio mode supported by the DUT. The 802.11 uplink interferer shall be produced by transmitting unicast UDP packets containing 1000 bytes to the DUT on a 1 – ms interval so that the ACKs of each packet serve as the interfering signal. The interferer shall be generated using a 20 MHz wide channel per the following criteria. Cellular desensitization tests shall only be performed with 802.11b, 2.4 GHz @ 11 Mbps, (Note: 802.11g/n/ax

devices at 2.4 GHz must support 802.11b at 2.4 GHz), 802.11a, 5 GHz @ 6Mbps (Note: 802.11n/ac/ax devices at 5 GHz must support 802.11a at 5 GHz), and 802.11ax, 6 GHz @ 7.3 Mbps. Devices that operate in the 2.4 GHz band shall be set to operate on Channel 6 ($f_c = 2437$ MHz). Devices that operate in the 5 GHz band shall be set to operate only on the middle channel of the lowest supported sub-band in the 5 GHz range (i.e., 44, 60, 120, 157, or 165).

4.9.2 Testing Procedure

The following test procedure demonstrates one possible process flow, but an alternate process order may be used, provided all required tests are performed.

1. For each independent 802.11 transmit antenna configuration, enable that configuration as the interferer. When a device contains multiple 802.11 TX antennas, the guidelines in *CTIA 01.01* [6] shall be used for configuring the 802.11 TX antennas.
2. Establish an 802.11 connection with the communication tester and transmit UDP packets to the DUT at the required rate as defined in Section 4.9.1 so that the DUT is generating ACK packets at the required periodic rate.
3. For cellular radio modes with free space limits:
 - a. For each cellular radio mode and applicable test configuration of the DUT, repeat the relative sensitivity test on all intermediate channels, including the low/mid/high reference channels, in the presence of the 802.11 uplink interference at maximum output power.
 - b. Report only the intermediate channels that exceed the relative sensitivity test limit.
4. For cellular radio modes without free space limits:
 - a. For each cellular radio mode and applicable test configuration of the DUT, repeat the FS $EIS_{(peak)}$ test for the low, mid and high channels in the presence of the 802.11 uplink interference at maximum output power. Please refer to the relative sensitivity testing process in Section 4.2 for a general definition of FS $EIS_{(peak)}$.
 - b. Report the FS $EIS_{(peak)}$ test results for the low, mid and high channels with and without the 802.11 interferer.

Repeat the process until all applicable cellular radio modes, test configurations, and 802.11 transmit configurations have been tested.

4.9.2.1 Minimum Measurement Distance Considerations

Due to the large form factor of typical notebooks, the minimum measurement distance criteria, in particular, the $2D^2/\lambda_u$ limit specified in *CTIA 01.73* [1] cannot be satisfied on shorter ranges.

For devices with a largest single dimension D (i.e., length, width, height) ≤ 0.42 m, a measurement distance R , where $R \geq 1.2$ m, is acceptable for TRP, TIS and average gain measurements. However, an additional standard uncertainty value must be included in the total DUT measurement uncertainty calculation to account for the violation of the far field as identified in *CTIA 01.70* [5]. Testing of devices with a largest single dimension $D > 0.42$ m is outside the scope of the guidance provided by this document.

Note that EM simulations indicate that the antenna current distribution for embedded WWAN platforms is not uniform over the DUT volume, but rather is highly localized along its outer edges adjacent to the antennas. Furthermore, the current distribution becomes more localized with increasing RF frequency. Consequently, the effective radiating aperture size D should be assumed equal to the largest single physical dimension of the DUT. For example, for a typical widescreen notebook computer, D is the width of the device, not the three-dimensional distance between one upper corner of the screen and the extreme opposite corner of the base.

4.9.3 Additional Measurement Uncertainty

4.9.3.1 Ripple Uncertainty

The ripple uncertainty associated with larger devices shall be determined as described in *CTIA 01.70* [5], using data collected from the additional ripple test procedure for notebook-sized volumes defined in Section 5.4 in *CTIA 01.73* [1].

4.9.3.2 Uncertainty Due to Minimum Measurement Distance

Please refer to *CTIA 01.70* [5] for guidance.

4.9.3.3 Additional Coarse Sampling Grid Uncertainty

The TIS measurement uncertainty associated with the measurement grids listed in [Table 4.9-1](#) is discussed in *CTIA 01.70* [5]. It is conceivable that this source of uncertainty is worse for devices larger than the handset+head phantom combination for which this effect was originally assessed. Any additional uncertainty is only expected to occur with the largest “desktop replacement” notebooks and remains a topic for further investigation.

Section 5 Measurement Uncertainty

5.1 Introduction

For the TRP and TIS tests described in this Test Plan, the chosen method for calculation of the measurement uncertainty is based on the *Guide to the Expression of Uncertainty in Measurement* published by the International Organization for Standardization (ISO) Geneva, Switzerland 1995 [12].

The ISO guide gives a general approach to calculating measurement uncertainty that is applicable to all types of measurements, the process involving the combination of the standard deviations (known as standard uncertainties) of the individual contributors by the root-sum-squares method. It does, however, contain some underlying assumptions that have, in the past, made it difficult to apply the approach directly to radiated measurements. For example, it requires that all the contributors to the overall uncertainty are independent, all in the same unit and are additive, requirements that lead to difficulties particularly when contributors in %, volts and dB are involved. ETSI documents *TR 102 273* [13] and *TR 100 028* [14] have specifically addressed these problems for radiated measurements and have derived a method for converting standard uncertainties from one unit (% , volts, dB) into another. [Table 5.1-1](#) gives the relevant conversion factors, but *TR 102 273* [13] should be fully consulted before they are used, because there are some conditions regarding their magnitudes.

Table 5.1-1 Standard Uncertainty Conversion Factors

Converting From Standard Uncertainties In:	Conversion Factor Multiply By:	To Standard Uncertainties In:
dB	11.5	voltage %
dB	23.0	power %
power %	0.0435	dB
power %	0.5	voltage %
voltage %	2.0	power %
voltage %	0.0870	dB

The requirement that the uncertainties are additive dictates that in radiated measurements (where all of the uncertainties multiply), all the individual uncertainties should be converted to dB (if necessary) so that the dBs can be added.

So, using the above to determine the method for uncertainty analysis in TRP and TIS radiated measurements, the following illustrates the practical steps involved:

1. Compile a complete list of the individual measurement uncertainties that contribute to a measurement;
2. Determine the maximum value of each uncertainty;
3. Determine the distribution of each uncertainty (rectangular, U-shaped, etc);
4. Calculate (if necessary) the standard uncertainty (i.e., standard deviation) of each uncertainty;
5. Convert the units (if necessary) of each uncertainty into the chosen unit i.e. dB;
6. Combine ALL the standard uncertainties by the root-sum-squares method to derive the 'combined standard uncertainty';

7. Under the assumption that the probability distribution of the combined standard uncertainty is Gaussian/Normal, multiply the resulting combined standard uncertainty by an expansion factor ' k ' (taken from Student's T-distribution, W.S. Gosset 1908) to derive the 'expanded uncertainty' for a given confidence level. All expanded uncertainties are quoted to 95% confidence level, so k is taken as 2 (theoretically k should be 1.96, but for convenience, the value 2 had been agreed). Expressed a different way, this gives 95% confidence that the true value is within 2 times the combined standard uncertainty of the measured value.

It is not suggested that this process be carried out at every individual test frequency since this would be extremely time consuming and tedious. Rather, for each band (e.g. 824 – 894 MHz for Cellular, 1850 – 1990 MHz for PCS, etc.), unless only a single value is specified, all the uncertainties should be evaluated over the entire frequency range for that band and the worst-case values within the band taken and used in the calculations. Admittedly, this could lead to slightly pessimistic overall values, but the bonus is in reduced measurement time and a one-hit process that will be applicable to any frequency within the relevant band.

The uncertainty contributions are determined experimentally. The relative uncertainty parameters can also be determined by simulations provided that it can be guaranteed that the relative accuracy is significantly better than 0.1 dB (see [CTIA 01.70 \[5\]](#).)

In Section [5.1](#) and [5.2](#), this calculation process is fully described for the TRP and TIS tests of this Test Plan respectively.

5.2 TRP Tests

The TRP test method determines the unknown performance of the DUT by correcting the absolute power measurements at the input port of the test instrumentation using a relative correction value determined using the range reference measurement described in [CTIA 01.73 \[1\]](#). This correction value offsets each power measurement back to the equivalent power that would have been radiated by a theoretical isotropic radiator in order to produce the same measured level. This corrected value is known as the Effective Isotropic Radiated Power (EIRP), which is then integrated across the total spherical surface to determine the Total Radiated Power. To reduce the overall measurement uncertainty, the same cable configuration and equipment used during the reference measurement (Section 4 in [CTIA 01.73 \[1\]](#)) should also be used during the DUT measurement phase, rather than measuring individual components and applying the corrections separately. In this way, a number of the individual uncertainty contributions will cancel simply because they contribute the same uncertainty to both the reference measurement and the DUT measurement, e.g. the uncertainty in the insertion loss of the cable(s) between the measurement antenna and the Spectrum Analyzer/Measurement Receiver, the uncertainty in the Gain of the measurement antenna, etc.

5.2.1 DUT Measurement

In this part of the measurement, the DUT and any associated phantom combination is positioned on the turntable within the quiet zone of the chamber, trying to place its reference point (as defined in [CTIA 01.71 \[7\]](#)) on the axes of rotation in both theta and phi (if present). At the other end, the spectrum analyzer, measurement receiver or communication tester will be connected via a cable and/or attenuator to the measurement antenna.

The identified uncertainties in this part are listed in [Table 5.2.1 1](#). Where 0.00 dB values are entered in [Table 5.2.1 1](#), this means that the uncertainty contribution appears in the reference measurement also and therefore cancels. It is a critical step in any such uncertainty evaluation to determine precisely where the transition occurs between the equipment that appears exactly in both measurements, vs. the equipment that changes between the reference measurement and the DUT measurement. The uncertainty contributions that can be assumed to cancel are those contributions associated with system components that are measured in the reference measurement. Since components such as the

measurement antenna and associated cables are measured in the reference measurement, there is one lump uncertainty associated with that measurement, rather than the individual uncertainties of each component.

CTIA 01.70 [5] gives guidance on calculating the values to be entered in Table 5.2.1-1.

Table 5.2.1-1 TRP Standard Uncertainties for the Contributions in the DUT Measurement Part

Description of Uncertainty Contributions	Standard Uncertainty, dB
Mismatch: measurement instrument (i.e., between the receiving device and the rest of the signal path [the measurement path])	See Section 2.1 in CTIA 01.70 [5]
Cable factor: measurement antenna cable (i.e. how the cable interacts with the measurement)	See Section 2.2 in CTIA 01.70 [5]
Insertion loss: measurement antenna cable	0.00 See Section 2.3 in CTIA 01.70 [5]
Insertion loss: measurement antenna attenuator (if present)	0.00 See Section 2.3 in CTIA 01.70 [5]
Receiving device: absolute level	See Section 2.4 in CTIA 01.70 [5]
Antenna: gain of the measurement antenna	0.00 See Section 2.2 in CTIA 01.70 [5]
Amplifier	See Section 2.7 in CTIA 01.70 [5]
Test System Frequency Flatness	See Section 2.28 in CTIA 01.70 [5]
Measurement distance: offset of DUT phase center from center of rotation 'blocking' effect of DUT on measurement antenna VSWR Chamber standing wave phase curvature across the DUT	See Sections: 2.9.1 2.9.3 2.9.3.1 2.9.3.2 2.34 in CTIA 01.70 [5]
Signal level ripple within quiet zone	See Section 2.10 in CTIA 01.70 [5]
DUT: influence of the ambient temperature on the ERP of the carrier	See Section 2.12 in CTIA 01.70 [5]
Head phantom uncertainty	See Section 2.13 in CTIA 01.70 [5]
Hand phantom uncertainty	See Section 2.13 in CTIA 01.70 [5]
Forearm phantom uncertainty	See Section 2.13 in CTIA 01.70 [5]
Head phantom fixture uncertainty	See Section 2.13 in CTIA 01.70 [5]
Hand phantom fixture uncertainty	See Section 2.13 in CTIA 01.70 [5]
Forearm phantom fixture uncertainty	0.00 See Section 2.13 in CTIA 01.70 [5]

Description of Uncertainty Contributions	Standard Uncertainty, dB
Chest phantom fixture uncertainty	0.00 See Section 2.13.4.3 in CTIA 01.70 [5]
DUT positioning uncertainty	See Section 2.17 in CTIA 01.70 [5]
Miscellaneous uncertainty (measurement system repeatability)	See Section 2.22 in CTIA 01.70 [5]
Special considerations for notebooks: Offset of the Phase Center of the DUT from Center of Rotation VSWR Chamber Standing Wave Additional Measurement Uncertainties for Inadequate Measurement Distance Signal Level Ripple Within Quiet Zone	See Sections: 2.9.1.2 2.9.3.1 2.9.3.2.1 2.9.4.1 2.10 in CTIA 01.70 [5]
Frequency flatness and interpolation error	See Section 2.29 in CTIA 01.70 [5]

Once all the relevant standard uncertainty values in [Table 5.2.1-1](#) have been calculated, they should be combined by root-sum-squares to give the combined standard uncertainty u_c contribution from the DUT measurement for this part of the test.

5.2.2 Reference Measurement

This is the Range Reference Measurement as given in [CTIA 01.73 \[1\]](#) the output of which is the Path Loss. It is believed that the uncertainty of the path loss calculation is a significant factor dictating the accuracy of the measured TRP value. Any error in the path loss calculation (e.g., error in the gain of the reference antenna) will result in an offset in the TRP value.

The contributors to the overall uncertainty of this part of the measurement are given in [Table 5.2.2-1](#). Again, the contributors that appear in both parts of the measurement are put equal to 0.00 because they have the same effect in both parts, provided the relevant parts of the test set-up have not been changed. Once all the standard uncertainty values have been derived, they shall be combined by root-sum-squares to give the following combined standard uncertainty u_c contribution from the reference measurement for this part of the test.

[CTIA 01.70 \[5\]](#) gives guidance on calculating the values to be entered in [Table 5.2.2-1](#).

Table 5.2.2-1 Standard Uncertainties for the Contributions to the Reference Measurement

Description of Uncertainty Contributions	Standard Uncertainty, dB
Mismatch: cable reference measurement (i.e., between the reference cable and the loopback cable)	See Section 2.1 in CTIA 01.70 [5]
Mismatch: reference antenna (i.e., between the reference cable and the reference antenna)	See Section 2.1 in CTIA 01.70 [5]

Description of Uncertainty Contributions	Standard Uncertainty, dB
Mismatch: measurement path (i.e., between the loopback cable and the rest of the cable that connects to the measurement equipment)	See Section 2.1 in <i>CTIA 01.70</i> [5]
Signal generator: absolute output level	See Section 2.5 & 2.6 in <i>CTIA 01.70</i> [5]
Signal generator: output level stability	See Section 2.5 & 2.6 in <i>CTIA 01.70</i> [5]
Insertion loss: calibrated reference antenna cable	See Section 2.3 in <i>CTIA 01.70</i> [5]
Insertion loss: measurement antenna cable	0.00 See Section 2.3 in <i>CTIA 01.70</i> [5]
Insertion loss: calibrated reference antenna attenuator (if present)	See Section 2.3 in <i>CTIA 01.70</i> [5]
Insertion loss: measurement antenna attenuator (if present)	0.00 See Section 2.3 in <i>CTIA 01.70</i> [5]
Receiving device: absolute level	See Section 2.4 in <i>CTIA 01.70</i> [5]
Amplifier	See Section 2.7 in <i>CTIA 01.70</i> [5]
Measurement distance: offset of phase center of calibrated reference antenna from the center of rotation	See Section 2.9.2 in <i>CTIA 01.70</i> [5]
Signal level ripple within quiet zone	See Section 2.10.3 in <i>CTIA 01.70</i> [5]
Antenna: gain of the calibrated reference antenna	See Section 2.8 in <i>CTIA 01.70</i> [5]
Antenna: gain of the measurement antenna	0.00

5.2.3 Calculation of the Combined and Expanded Uncertainties for the Overall TRP Measurement

Having calculated the combined standard uncertainties from the two parts of the measurement, they should be combined as follows to derive the overall combined standard uncertainty:

$$u_c = \sqrt{u_{c \text{ contribution from the DUT measurement}}^2 + u_{c \text{ contribution from the reference measurement}}^2}$$

From this, the expanded uncertainty, U , is calculated as $U = 2 \cdot u_c$ for a 95 % confidence level.

This is the resulting value of the TRP expanded uncertainty and should be stated in the results sheet.

5.3 TIS Tests

The TIS test method is similar to the TRP method above, in that the range reference measurement is used to correct the unknown performance of the DUT back to values relative to that of a theoretical isotropic receiver. In this case, the correction value offsets each sensitivity level measurement back to the equivalent sensitivity level of a theoretical isotropic receiver exposed to an incoming isotropic wave with the same magnitude. This corrected value is known as the Effective Isotropic Sensitivity (EIS), which is then integrated across the total spherical surface to determine the Total Isotropic Sensitivity. As above, a

number of individual uncertainty contributions will cancel, provided there have only been a minimum number of changes between the two parts of the measurement.

5.3.1 DUT Measurement

In this part of the measurement, the DUT is positioned within the quiet zone of the turntable, again trying to position its ear reference point on the axes of rotation in both azimuth and elevation (if present). At the other end, the communication tester will be connected via a cable and/or attenuator to the measurement antenna.

The identified uncertainties in this part are listed in [Table 5.3.1-1](#).

[CTIA 01.70 \[5\]](#) gives guidance on calculating the values to be entered in [Table 5.3.1-1](#).

Table 5.3.1-1 TIS Standard Uncertainties for the Contributions in the DUT Measurement Part

Description of Uncertainty Contributions	Standard Uncertainty, dB
Mismatch: measurement instrument (i.e., between the transmitting device and the rest of the signal path [the measurement path])	See Section 2.1 in CTIA 01.70 [5]
Communication tester/satellite simulator: absolute output level	See Section 2.5 in CTIA 01.70 [5]
Communication tester/satellite simulator: output level stability	See Section 2.5 in CTIA 01.70 [5]
Cable factor: measurement antenna cable (i.e. how the cable interacts with the measurement)	0.00 See Section 2.2 in CTIA 01.70 [5]
Insertion loss: measurement antenna cable	0.00 See Section 2.3 in CTIA 01.70 [5]
Insertion loss measurement antenna attenuator (if present)	0.00 See Section 2.3 in CTIA 01.70 [5]
Amplifier	See Section 2.7 in CTIA 01.70 [5]
Test System Frequency Flatness Uncertainty	See Section 2.28 in CTIA 01.70 [5]
Receiver performance search step size	See Section 2.20 in CTIA 01.70 [5]
DUT influence of ambient temperature on the EIS	See Section 2.12 in CTIA 01.70 [5]
Measurement distance: offset of DUT phase center from center of rotation 'blocking' effect of DUT on measurement antenna VSWR Chamber standing wave phase curvature across the DUT	See Sections: 2.9.1 2.9.3 2.9.3.1 2.9.3.2 2.34 in CTIA 01.70 [5]
Signal level ripple within quiet zone	See Section 2.10 in CTIA 01.70 [5]
Antenna: gain of the measurement antenna	0.00 See Section 2.2 in CTIA 01.70 [5]

Description of Uncertainty Contributions	Standard Uncertainty, dB
Head phantom uncertainty	See Section 2.13 in <i>CTIA 01.70</i> [5]
Hand phantom uncertainty	See Section 2.13 in <i>CTIA 01.70</i> [5]
Forearm phantom uncertainty	See Section 2.13 in <i>CTIA 01.70</i> [5]
Head phantom fixture uncertainty	See Section 2.13 in <i>CTIA 01.70</i> [5]
Hand phantom fixture uncertainty	See Section 2.13 in <i>CTIA 01.70</i> [5]
Forearm phantom fixture uncertainty	0.00 See Section 2.13 in <i>CTIA 01.70</i> [5]
Chest phantom fixture uncertainty	0.00 See Section 2.13.4.3 in <i>CTIA 01.70</i> [5]
DUT positioning uncertainty	See Section 2.17 in <i>CTIA 01.70</i> [5]
Coarse sampling grid contribution	See Section 2.21 in <i>CTIA 01.70</i> [5]
Miscellaneous uncertainty	See Section 2.22 in <i>CTIA 01.70</i> [5]
Special considerations for notebooks: Offset of the Phase Center of the DUT from Center of Rotation VSWR Chamber Standing Wave Additional Measurement Uncertainties for Inadequate Measurement Distance Signal Level Ripple Within Quiet Zone	See Sections: 2.9.1.2 2.9.3.1 2.9.3.2.1 2.9.4.1 2.10 in <i>CTIA 01.70</i> [5]
Frequency flatness and interpolation error	See Section 2.29 in <i>CTIA 01.70</i> [5]
The following additional items apply to RSS-based TIS:	
Communication tester/satellite simulator: relative output level	See Section 2.5 in <i>CTIA 01.70</i> [5]
DUT repositioning uncertainty	See Section 2.17 in <i>CTIA 01.70</i> [5]
Linearization of conducted/radiated RSS measurement	See Section 2.24 in <i>CTIA 01.70</i> [5]
Uncertainty of RSS data from DUT	See Section 2.25 in <i>CTIA 01.70</i> [5]
Quantization of DUT reporting mechanism for RSS data	See Section 2.26 in <i>CTIA 01.70</i> [5]

The standard uncertainties from [Table 5.3.1-1](#) should be combined by root-sum-squares to give the combined standard uncertainty u_c contribution from the DUT measurement for this part of the test.

5.3.2 Reference Measurement

This is the identical analysis to that given in [Section 5.2.2](#) above since it is the same Range Reference Measurement as described in [Section 3](#) in *CTIA 01.73* [1] the output of which is the Path Loss.

The contributors to the overall uncertainty of this part of the measurement are given in [Table 5.3.2-1](#). Again, those contributors that appear in both parts of the measurement are put equal to 0.00 because they have the same effect in both parts. Once all the standard uncertainty values have been derived, they should be combined by root-sum-squares to give the combined standard uncertainty

u_c contribution from the reference measurement for this part of the test.

CTIA 01.70 [5] gives guidance on calculating the values to be entered in [Table 5.3.2-1](#).

Table 5.3.2-1 Standard Uncertainties for the Contributions to the Reference Measurement

Description of Uncertainty Contributions	Standard Uncertainty, dB
Mismatch: cable reference measurement (i.e., between the reference cable and the loopback cable)	See Section 2.1 in CTIA 01.70 [5]
Mismatch: reference antenna (i.e., between the reference cable and the reference antenna)	See Section 2.1 in CTIA 01.70 [5]
Mismatch: measurement path (i.e., between the loopback cable and the rest of the cable that connects to the measurement equipment)	See Section 2.1 in CTIA 01.70 [5]
Signal generator: absolute output level	See Section 2.5 & 2.6 in CTIA 01.70 [5]
Signal generator: output level stability	See Section 2.5 & 2.6 in CTIA 01.70 [5]
Insertion loss: Calibrated reference antenna cable	See Section 2.3 in CTIA 01.70 [5]
Insertion loss: measurement antenna cable	0.00 See Section 2.3 in CTIA 01.70 [5]
Insertion loss: calibrated reference antenna attenuator (if present)	See Section 2.3 in CTIA 01.70 [5]
Insertion loss: measurement antenna attenuator (if present)	0.00 See Section 2.3 in CTIA 01.70 [5]
Receiving device: absolute level	See Section 2.4 in CTIA 01.70 [5]
Amplifier	See Section 2.7 in CTIA 01.70 [5]
Measurement distance: offset of phase center of calibrated reference antenna from the center of rotation	See Section 2.9 in CTIA 01.70 [5]
Signal level ripple within quiet zone	See Section 2.10 in CTIA 01.70 [5]
Antenna: gain of the calibrated reference Antenna	See Section 2.8 in CTIA 01.70 [5]
Antenna: gain of the measurement antenna	0.00 See Section 2.2 in CTIA 01.70 [5]

5.3.3 Calculation of the Combined and Expanded Uncertainties for the Overall TIS Measurement

Having calculated the combined standard uncertainties from the two parts of the measurement, they should be combined as follows to derive the overall combined standard uncertainty

$$u_c = \sqrt{u_c^2 \text{ contribution from the DUT measurement} + u_c^2 \text{ contribution from the reference measurement}}$$

From this, the expanded uncertainty, U , is calculated as $U = 2 \cdot u_c$ for a 95 % confidence level.

This is the resulting value of the TIS expanded uncertainty and should be stated in the results sheet.

5.4 Alternate Test Procedures for TRP Measurements

5.4.1 Single/Multi-point Offset TRP Test

For purposes of clarity, test configuration A will be the reference protocol for which a full TRP measurement is performed. Test configuration B will be the other protocol to be tested using the single/multi point radiated test.

Since this alternative measurement is a relative measurement, it will not only inherit the same uncertainties as those in the full 3D TRP measurement for test configuration A but will additionally include a small number of extra uncertainties. These extra uncertainties shall be combined with the combined uncertainty of the full TRP measurement by root-sum-squares in order to derive an overall estimate for the uncertainty of this relative measurement procedure that results in an absolute level for test configuration B TRP.

Since this is a relative measurement, many of the uncertainties associated with measuring test configuration B and test configuration A with the phone in the same position, near the same time, will be the same and cancel. Therefore, they will not contribute to the relative measurement. The uncertainties, which will cancel, include mismatch between measurement antenna and receiving device, cable effects, insertion loss of the measurement antenna cable and attenuator, measurement antenna gain, measurement distance, signal level ripple within quiet zone, influence of ambient temperature on radiated power, and dissimilarity between calibration antenna and DUT. The error/uncertainty contribution for each of the above items is listed in [Table 5.4.1-1](#). If the phone is not handled between measuring both test configurations, then the positioning error of DUT uncertainty will not contribute to this measurement. If the phone is handled between measuring both test configurations, then this uncertainty should be included in this measurement.

One of the additional sources of uncertainty is the variation in gain pattern over frequency. This will have a small impact if the channel bandwidth of test configuration A and test configuration B is different. For example, for LTE 10 MHz channel BW using 12 RBs and GSM the occupied bandwidths are 2.16 MHz vs. 200 kHz. Other protocol pairs may have no variation, because their channel bandwidths are the same.

Another additional uncertainty is that associated with determining the difference in received levels of the test configurations. The magnitude of this uncertainty is minimized if the same receiving device is used for both measurements. Finally, a miscellaneous uncertainty component is considered for the relative measurement.

Other than the uncertainties identified above, the test configuration B measurement will inherit the exact same errors as the test configuration A measurement.

Table 5.4.1-1 Additional Uncertainties Between Relative Measurement vs. Full TRP Measurement

Description of Uncertainty Contributions	Added Uncertainty, dB
Mismatch: receiving part (i.e., between receiving device and measurement antenna)	0.00 See Section 2.1 in <i>CTIA 01.70</i> [5]
Cable factor: measurement antenna cable (i.e. how the cable interacts with the measurement)	0.00 See Section 2.2 in <i>CTIA 01.70</i> [5]
Insertion loss: measurement antenna cable	0.00 See Section 2.3 in <i>CTIA 01.70</i> [5]

Description of Uncertainty Contributions	Added Uncertainty, dB
Insertion loss: measurement antenna attenuator (if present)	0.00 See Section 2.3 in CTIA 01.70 [5]
Receiving device: absolute level	See Section 2.4 in CTIA 01.70 [5]
Antenna: gain of the measurement antenna	0.00 See Section 2.2 in CTIA 01.70 [5]
Measurement distance: offset of DUT phase center from center of rotation 'blocking' effect of DUT on measurement antenna VSWR Chamber standing wave phase curvature across the DUT	See Sections: 2.9.1 2.9.3 2.9.3.1 2.9.3.2 2.34 in CTIA 01.70 [5]
Signal level ripple within quiet zone	0.00 See Section 2.10 in CTIA 01.70 [5]
Influence of the ambient temperature on test equipment	0.00 See Section 2.12 in CTIA 01.70 [5]
DUT repositioning uncertainty	See Section 2.17 in CTIA 01.70 [5]
Miscellaneous uncertainty	See Section 2.22 in CTIA 01.70 [5]
Uncertainty due to difference in gain of the test antenna over the different channel bandwidths	See Section 2.27 in CTIA 01.70 [5]

Calculation of absolute uncertainty for TRP calculated using a relative single-point/multi-point radiated measurement:

The non-zero uncertainty values in the table above shall be combined by root-sum-squares to produce:

$$u_{c TRP \text{ relative measurement}}$$

The overall uncertainty for the measurement is then:

$$u_c = \sqrt{u_{c TIS \text{ relative measurement}}^2 + u_{c \text{ full TIS measurement}}^2}$$

From this, the expanded uncertainty, U , is calculated as $U = 2 \cdot u_c$ for a 95% confidence level.

This is the resulting value of the TRP expanded uncertainty for the alternate measurement procedure and should be stated in the results sheet.

5.5 Alternate Test Procedures for TIS Measurements

5.5.1 Single/Multi-point Offset TIS Test Procedure

For purposes of clarity, test configuration A will be protocol/error rate/data rate for which a full TIS measurement is performed. Test configuration B will be the other protocol/error rate/data rate which will be tested using the single/multi-point radiated test.

Since this alternative measurement is a relative measurement, it will not only inherit the same uncertainties as those in the full 3D TIS measurement for test configuration A but will additionally include a small number of extra uncertainties. These extra uncertainties shall be combined with the combined uncertainty of the full TIS measurement by root-sum-squares in order to derive an overall estimate for the uncertainty of this relative measurement procedure that results in an absolute level for test configuration B TIS.

Since this is a relative measurement, many of the uncertainties associated with measuring test configuration B and test configuration A with the phone in the same position, near the same time, will be the same and cancel. Therefore, they will not contribute to the relative measurement. The uncertainties, which will cancel, include mismatch between measurement antenna and receiving device, cable effects, insertion loss of the measurement antenna cable and attenuator, measurement antenna gain, measurement distance, signal level ripple within quiet zone, influence of ambient temperature on radiated sensitivity, and dissimilarity between calibration antenna and DUT. The error/uncertainty contribution for each of the above items is listed in [Table 5.4.1-1](#). If the phone is not handled between measuring both test configurations, then the positioning error of DUT uncertainty will not contribute to this measurement. If the phone is handled between measuring both test configurations, then this uncertainty should be included in this measurement.

An additional source of uncertainty is the variation in gain pattern over frequency. This will have a small impact if the channel bandwidth of test configuration A and test configuration B is different. For example, for LTE 10 MHz channel BW using 50 RBs and GSM the occupied bandwidths are 9 MHz vs. 200 kHz. Other test configuration pairs may have no variation, because their channel bandwidths are the same.

Another additional uncertainty is that associated with determining the difference in received levels of the test configurations. The magnitude of this uncertainty is minimized if the same communication tester is used for both measurements. Finally, a miscellaneous uncertainty component is considered for the relative measurement.

Other than the uncertainties identified above, the test configuration B measurement will inherit the exact same errors as the test configuration A measurement.

Table 5.5.1-1 Additional Uncertainties Between Relative Measurement vs. Full TIS Measurement

Description of Uncertainty Contributions	Added Uncertainty, dB
TIS normalization uncertainty	See Section 2.23 in CTIA 01.70 [5]
Mismatch: receiving part (i.e., between receiving device and measurement antenna)	0.00 See Section 2.1 in CTIA 01.70 [5]
Cable factor: measurement antenna cable (i.e., how the cable interacts with the measurement)	0.00 See Section 2.2 in CTIA 01.70 [5]
Insertion loss: measurement antenna cable	0.00 See Section 2.3 in CTIA 01.70 [5]
Insertion loss: measurement antenna attenuator (if present)	0.00 See Section 2.3 in CTIA 01.70 [5]
Communication tester: absolute/relative level	See Section 2.5 in CTIA 01.70 [5]
Antenna: gain of the measurement antenna	0.00 See Section 2.2 in CTIA 01.70 [5]
Measurement distance: offset of DUT phase center from center of rotation 'blocking' effect of DUT on measurement antenna VSWR Chamber standing wave phase curvature across the DUT	See Sections: 2.9.1 2.9.3 2.9.3.1 2.9.3.2 2.34 in CTIA 01.70 [5]
Signal level ripple within quiet zone	0.00 See Section 2.10 in CTIA 01.70 [5]
Influence of the ambient temperature on the radiated sensitivity of the test equipment	0.00 See Section 2.12 in CTIA 01.70 [5]
DUT repositioning uncertainty	See Section 2.18 in CTIA 01.70 [5]
Miscellaneous uncertainty	See Section 2.22 in CTIA 01.70 [5]
Uncertainty due to difference in gain of the test antenna over the different channel bandwidths	See Section 2.27 in CTIA 01.70 [5]

Calculation of absolute uncertainty for TIS calculated using a relative single-point/multi-point radiated measurement:

The non-zero uncertainty values in the table above shall be combined by root-sum-squares to produce:

$$u_c \text{ TIS relative measurement}$$

The overall uncertainty for the measurement is then:

$$u_c = \sqrt{u_c^2 \text{ TIS relative measurement} + u_c^2 \text{ full TIS measurement}}$$

From this, the expanded uncertainty, U , is calculated as $U = 2 \cdot u_c$ for a 95% confidence level.

This is the resulting value of the TIS expanded uncertainty for the measurement and should be stated in the results sheet.

5.6 Criteria—Measurement Uncertainty

The results of the calculations for expanded uncertainty for both TRP and TIS measurements shall be reported, along with full documentation to support the resulting values. The test performance requirements shall not be adjusted by the measurement uncertainty when determining compliance of the DUTs.

The expanded TRP and TIS uncertainties must not exceed the values in [Table 5.6-1](#) a 95% confidence level.

Table 5.6-1 Expanded Uncertainty Maximum Limits for Different Configurations for TRP and TIS

Expanded Uncertainty (dB)				
Test Configuration	TRP ($f \leq 3\text{GHz}$)	TRP ($3\text{GHz} < f \leq 6\text{GHz}$)	TIS ($f \leq 3\text{GHz}$)	TIS ($3\text{GHz} < f \leq 6\text{GHz}$)
Free Space	2	2.3	2.3	2.6
Beside Head and Hand Left and Beside Head and Hand Right	2.4	2.7	2.6	2.9
Hand Left and Hand Right	2.2	2.5	2.4	2.7
Wrist-worn Left and Wrist-worn Right	2.2	2.5	2.4	2.7
Additional MU allowance for 50cm quiet zone	0	0.3	0	0.3
Additional MU allowance for "alternate" method	0	0.3	0	0.3
Additional MU allowance for Fast TIS ¹	0	0	0.3	0.3

Note 1: an Additional Allowance of 0.3 dB corresponds to approximately 1 dB of additional uncertainty due to the specific configuration or method.

Section 6 Test Set-up Configurations

6.1 Test Systems Set-up

Each of the two referenced chamber setups have different coordinate system orientations. This is due to the difference in implementation of the chamber axes. However, the DUT coordinate systems of the previous sections will apply independent of the physical orientations of the DUT inside the chamber.

Figure 6.1-1 below shows the typical setup using a combined-axes system. In addition to the pictured theta-axis rotation, the DUT will have to be rotated about the Z-axis (phi rotation) in order to perform the full spherical scans. For more details regarding the measurement distance R , see Section 2 in CTIA 01.73 [1].

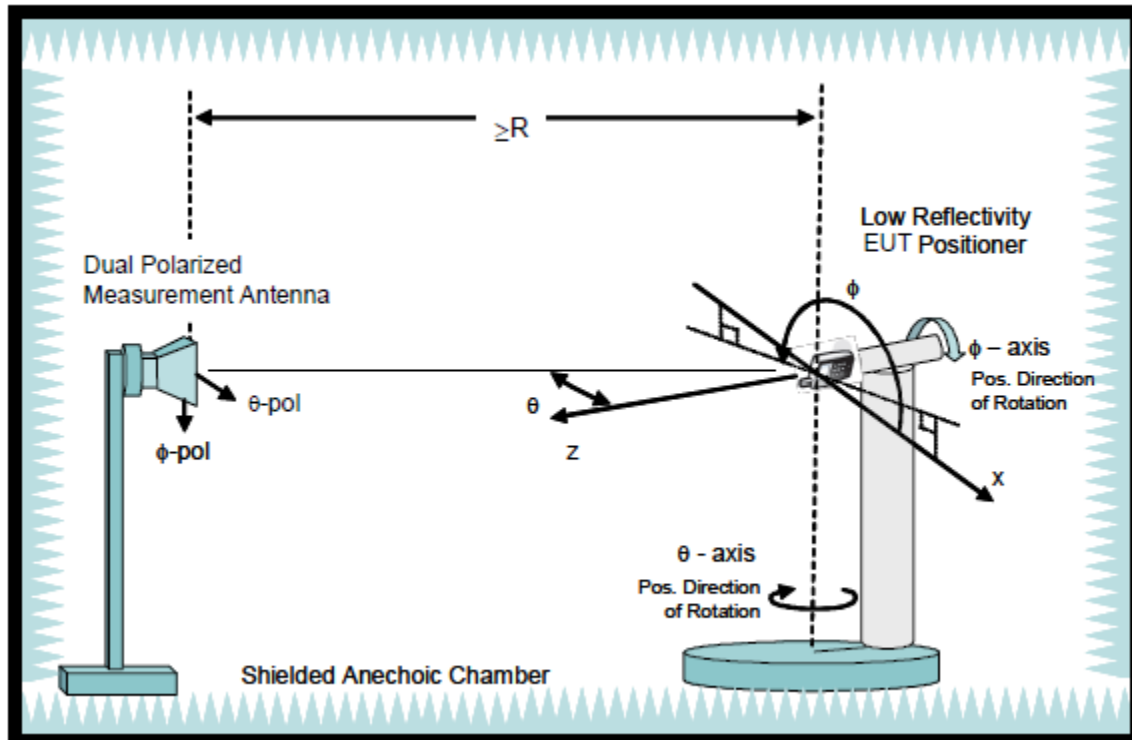

Figure 6.1-1 Typical Setup for a Combined-Axes System

Figure 6.1-2 below shows the typical setup using the distributed-axes system. In this configuration, the phi and theta angles are traversed separately by the distributed positioners in the chamber.

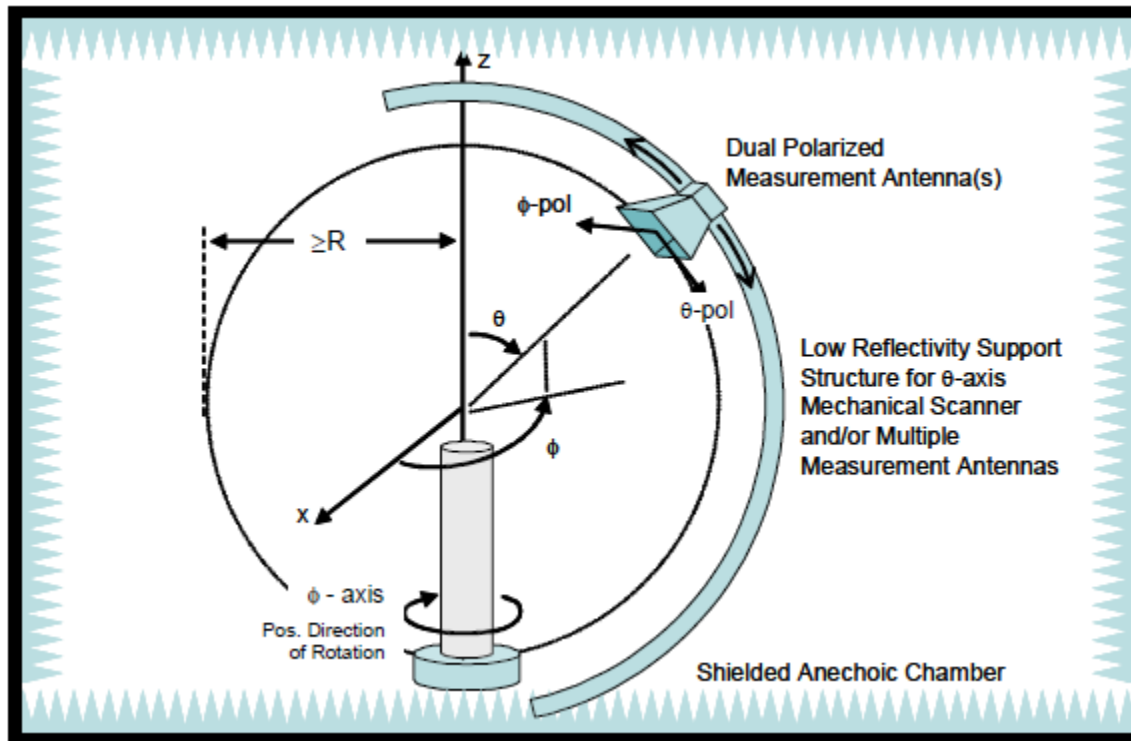

Figure 6.1-2 Typical Setup for a Distributed-Axes System

6.2 Test Setup—Instrumentation

Typical system schematics for both TRP and TIS measurements are shown in Figure 6.2-1 through Figure 6.2-7. The shown configurations are only representative examples of common measurement systems and do not represent an exhaustive list of allowable configurations. For more details regarding selection and configuration of measurement instrumentation, see Section 9 in *CTIA 01.73* [1].

Figure 6.2-1 through Figure 6.2-7 also include illustrations showing conducted power and conducted sensitivity measurement setups. It is recommended that the conducted measurements be performed inside a shielded environment. For conducted TIS measurements, a shielded environment is required since interferences can directly influence the measurement results. For conducted transmit power tests, a shielded environment is recommended since interference signals may cause dropped calls during the power measurement. The mobile DUT antenna connector is typically a special miniature RF connector on the DUT and is used as a RF-Test-Jack for conducted measurements. If the DUT does not readily support an antenna port for conducted measurements, a separate modified DUT may be provided for all conducted measurements. The mobile manufacturer must provide an RF test cable that terminates in a common SMA or N type connector to mate with the DUT antenna connector, along with the associated RF insertion loss for that cable connection. The insertion loss of the RF-Test-Cable must be factored into measurements referenced to the antenna connector.

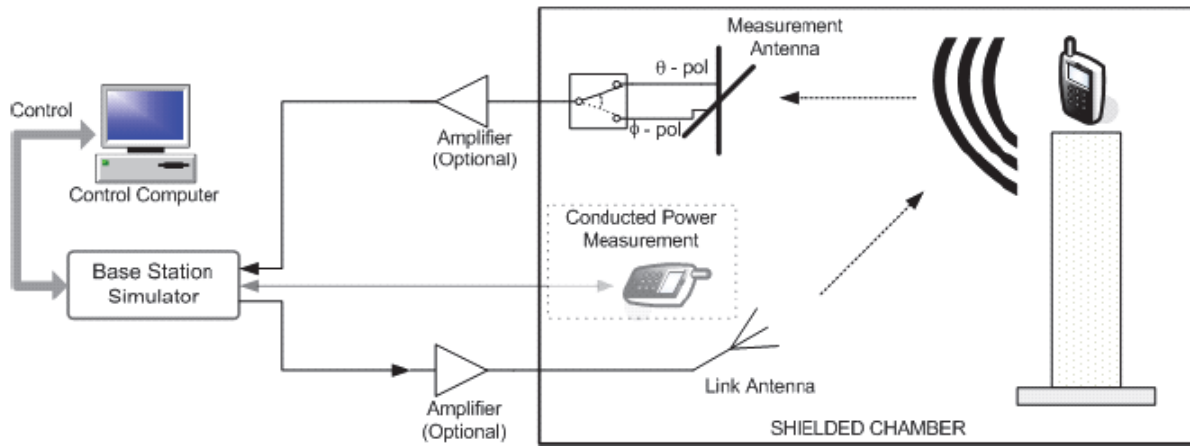

Figure 6.2-1 Simplified Block Diagram Showing a Common Configuration for the Use Of A Communication Tester for TRP Measurements

The forward link communication is transmitted through the communication link antenna and the reverse link is received through the measurement antenna. This configuration supports amplification of both signal paths if necessary.

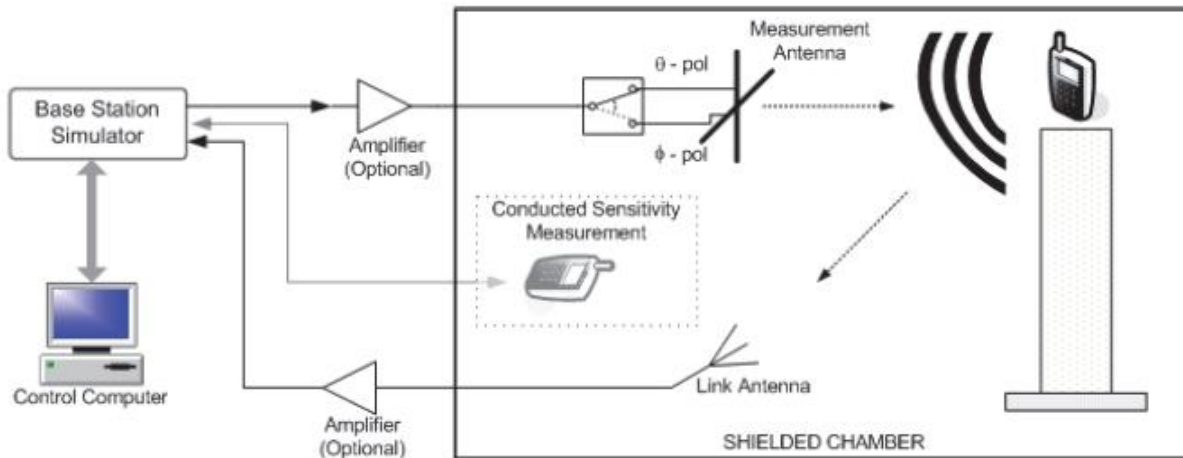

Figure 6.2-2 Simplified Block Diagram Showing a Common Configuration for TIS Measurements

The forward link communication is transmitted through the measurement antenna and the reverse link is received through the communication link antenna. This configuration supports amplification of both signal paths if necessary.

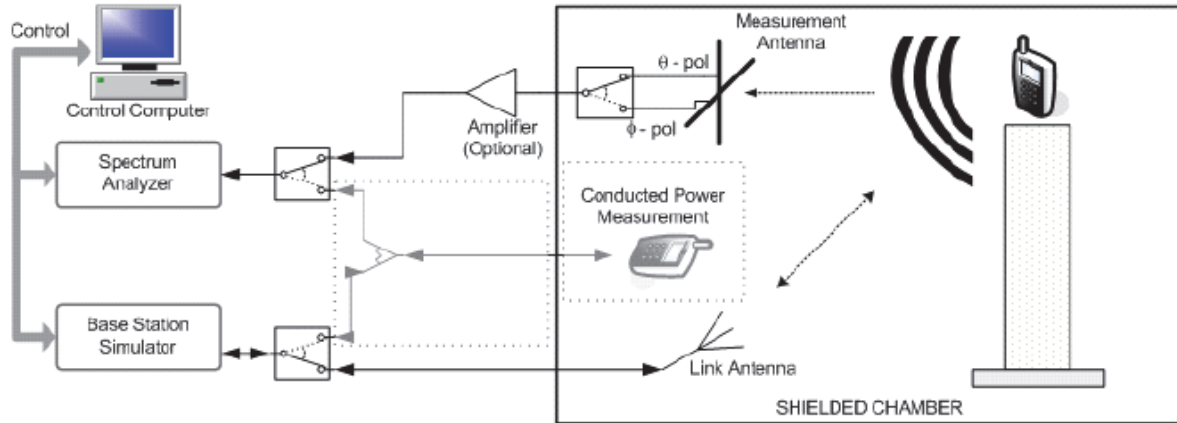

Figure 6.2-3 Simplified Block Diagram for TRP Measurements Using a Spectrum Analyzer

Both forward and reverse link communications between the mobile and communication tester are carried out through a separate communication link antenna. Instead of a spectrum analyzer, any other dedicated receiver can be used.

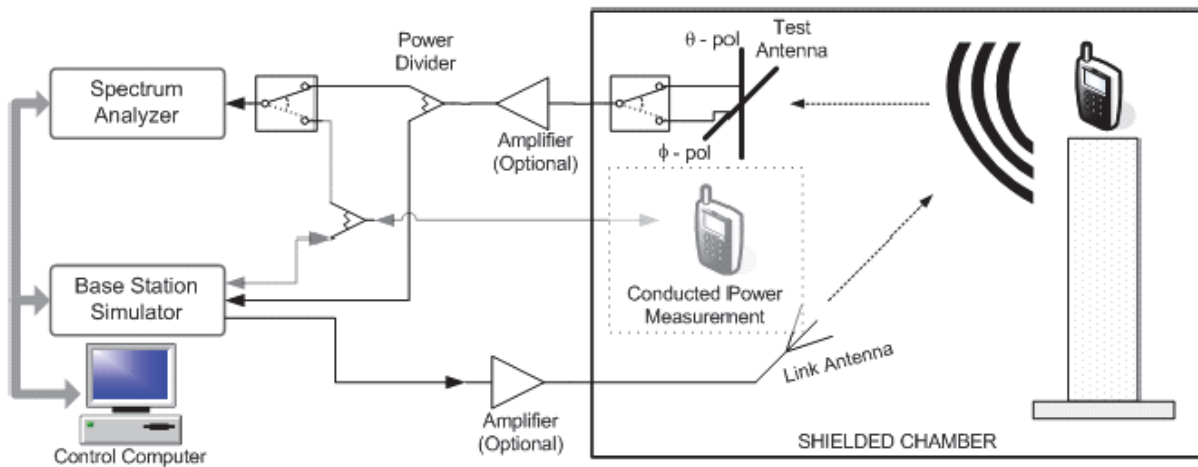

Figure 6.2-4 Simplified Block Diagram for TRP Measurements Using a Spectrum Analyzer with a Power Divider

Forward link communication between the mobile and communication tester is carried out through a separate communication link antenna while the reverse link is carried through the measurement antenna. Instead of a spectrum analyzer, any other dedicated receiver can be used.

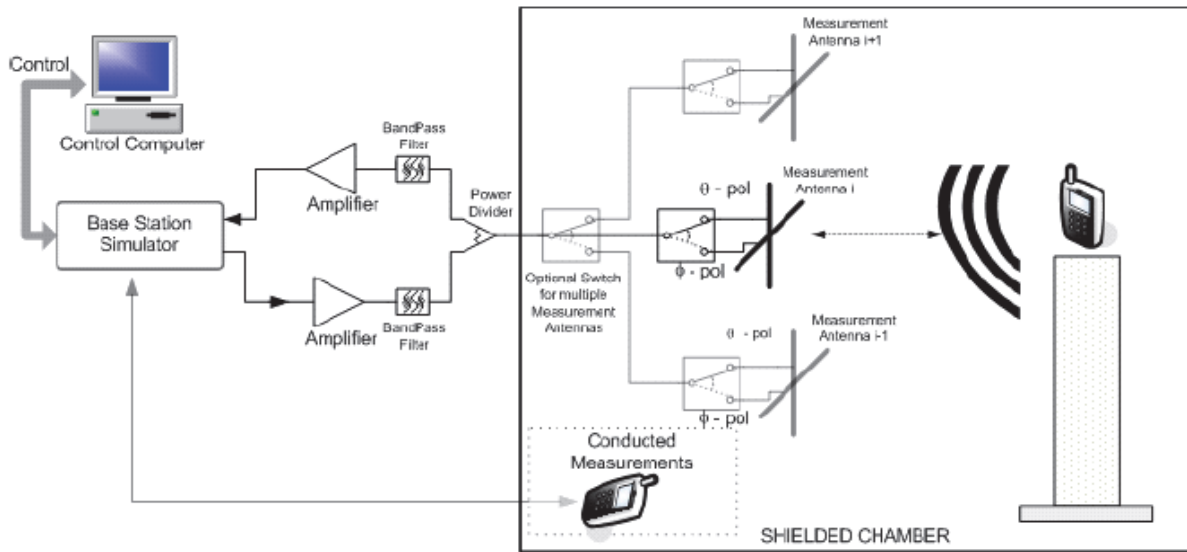

Figure 6.2-5 Simplified Block Diagram Illustrating a Method with External Amplifiers

The method of externally amplifying both forward and reverse link communication signals and combining them into one signal routed to/from one (or more) measurement antenna(s) is shown. This configuration supports both TRP and TIS measurements.

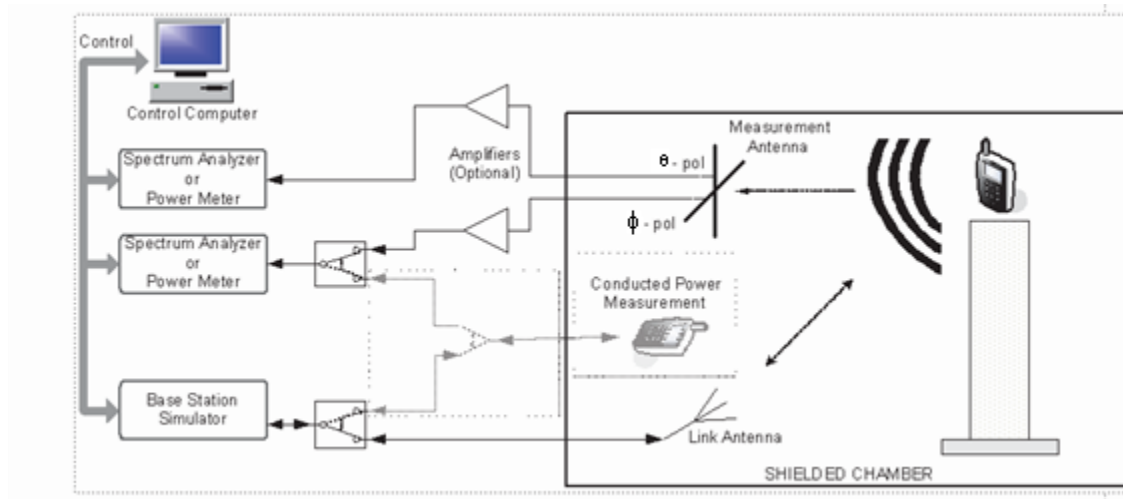

Figure 6.2-6 Simplified Block Diagram for TRP Measurements Using Dual Spectrum Analyzers

Both forward and reverse link communications between the mobile and communication tester are carried out through a separate communication link antenna. Instead of a spectrum analyzer, any other dedicated receiver can be used.

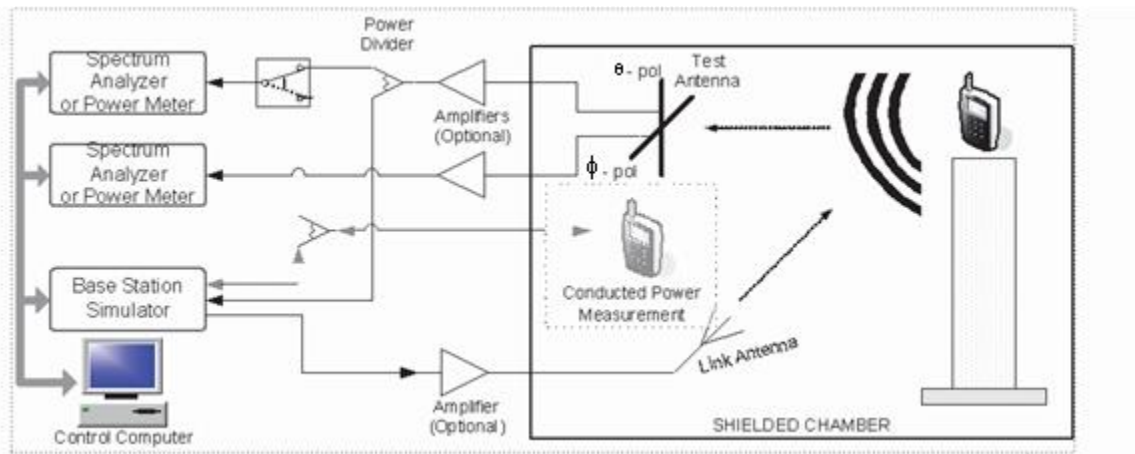

Figure 6.2-7 Simplified Block Diagram for TRP Measurements Using Dual Spectrum Analyzers and a Power Divider

Forward link communication between the mobile and communication tester is carried out through a separate communication link antenna while the reverse link is carried out through the measurement antenna. Instead of a spectrum analyzer, any other dedicated receiver can be used.

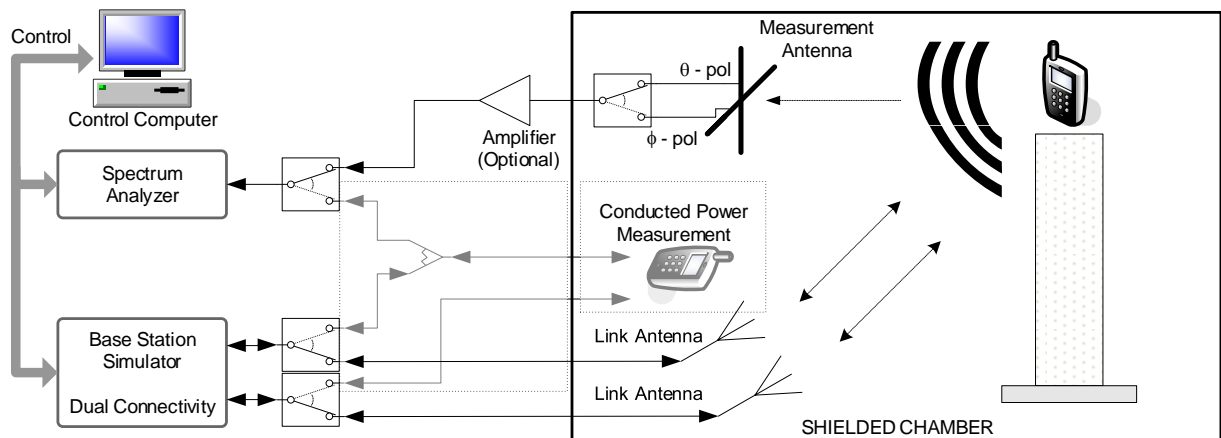

Figure 6.2-8 Simplified Block Diagram for TRP Measurements on Dual Connectivity Using a Spectrum Analyzer

For the RAT under test, both forward and reverse link communications between the mobile and communication tester are carried out through a separate communication link antenna. For the untested RAT, another link antenna can be assigned to provide a stable and noise-free connection without precise path loss or polarization control. Instead of a spectrum analyzer, any other dedicated receiver may be used.

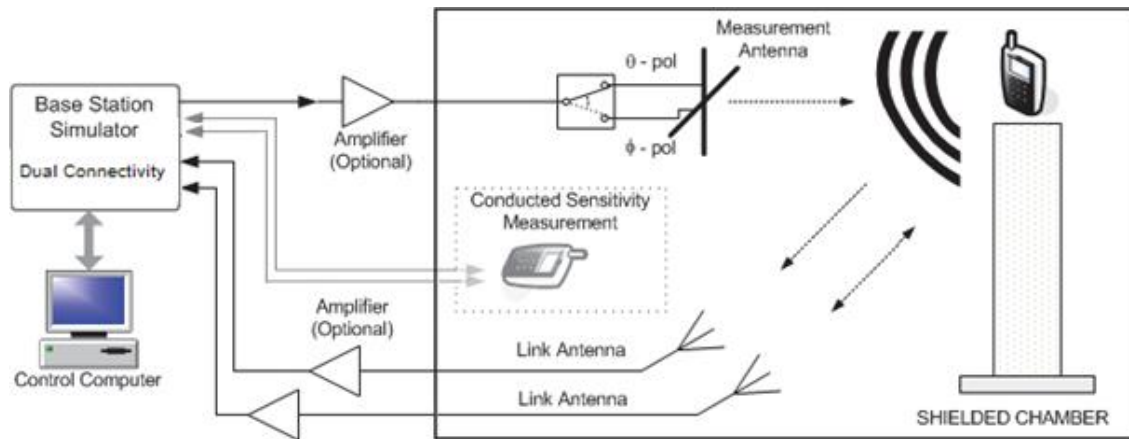

Figure 6.2-9 Simplified Block Diagram Showing a Common Configuration for TIS Measurements on Dual Connectivity

For the RAT under test, the forward link communication is transmitted through the measurement antenna and the reverse link is received through the communication link antenna. For the untested RAT, another link antenna can be assigned to provide a stable and error-free connection without precise path loss or polarization control. This configuration supports amplification of all signal paths if necessary.

Appendix A Revision History

Date	Version	Description
February 2022	4.0.0	Baseline release. The following changes were made compared to Version 3.9.3: Section 2: Updated Section 2.1, Section 2.2, Section 2.4, and Section 2.5 to accommodate Clenshaw-Curtis quadrature. Added Section 2.6 for the SAM phantom head special positioning considerations Section 6: Add Figure 6.2-8 and Figure 6.2-9 for Dual Connectivity TRP/TIS configuration
December 2022	5.0.0	Section 3: <ul style="list-style-type: none"> • Update Section 3.6 to introduce relative power on intermediate channel measurement Section 4: <ul style="list-style-type: none"> • Update Section 4.2 to cover lower mid/upper mid reference channels. Update Section 4.7 to clarify RSS based TIS applicability. Section 5: <ul style="list-style-type: none"> • Update Section 5.6 for fast TIS method MU budget
March 2023	6.0.0	Section 2: <ul style="list-style-type: none"> • Update Section 2.4 and Section 2.5 to introduce coarser measurement grids • Update Section 2.7 to introduce coarser measurement grids for theta dependent phi step size optimization Section 3: <ul style="list-style-type: none"> • Update Section 3.1 to introduce coarser measurement grids for TRP • Update Section 3.4 to note that spiral scan procedure with coarser measurement grids is FFS • Update Section 3.5 to revise the test procedure of TRP measurement for low transmit duty-cycle devices Section 4: <ul style="list-style-type: none"> • Update Section 4.1 to introduce coarser measurement grids for TIS • Update Section 4.8 to revise the test procedure of TIS measurement of low transmit duty-cycle devices • Update Section 4.9 to introduce coarser measurement grids
December 2023	6.0.1	Section 3: <ul style="list-style-type: none"> • Update Section 3.6 to clarify relative power on intermediate channel measurements. Section 4: <ul style="list-style-type: none"> • Update Section 4.2 to remove BLER threshold in LTE/NR FR1

Date	Version	Description
June 2024	6.0.2	<p>Section 1:</p> <ul style="list-style-type: none">Update Section 1.1 to correct a reference number <p>Section 4:</p> <ul style="list-style-type: none">Update Section 4.1 to correct typo and missing referenceUpdate Section 4.8 to specify the reference for IC measurementUpdate Section 4.9.1 to clarify the required supported test mode for Wi-Fi 2.4/5 GHz bandsUpdate Section 4.9.2 to maintain Wi-Fi interferer at the maximum power