



Battery Life Test Plan

Version 2.0.1

August 2024

© 2016 - 2024 CTIA Certification. All Rights Reserved.

Any reproduction, modification, alteration, creation of a derivative work, or transmission of all or any part of this publication ("Test Plan"), in any form, by any means, whether electronic or mechanical, including photocopying, recording, or via any information storage and retrieval system, without the prior written permission of CTIA Certification, is unauthorized and strictly prohibited by federal copyright law. This Test Plan is solely for use within the CTIA Certification Program. Any other use of this Test Plan is strictly prohibited unless authorized by CTIA Certification or its assigns in writing.

CTIA Certification LLC
1400 16th Street, NW
Suite 600
Washington, DC 20036

1.202.785.0081

programs@ctiacertification.org

Table of Contents

Section 1	Introduction	6
1.1	Purpose	6
1.2	Scope.....	6
1.3	Reference Documents	6
1.4	Test Process	6
1.5	Acronyms and Definitions	7
Section 2	Test Conditions and Generic Setup.....	9
2.1	Ambient Test Conditions	9
2.2	Temperature	9
2.3	Display Settings	9
2.4	Test Case Procedures.....	11
2.5	RF Parameters	11
2.6	Sampling Rate	12
2.7	DUT Configuration Prior to Testing	12
2.8	DUT Wait Time Before Testing.....	13
2.9	DUT Configuration During Testing	13
2.10	Power Supply and Analyzer	13
2.11	Wearables.....	15
2.11.1	Smartwatches	15
2.12	SIM Cards	16
2.13	GNSS Simulator	16
Section 3	Total Available Energy.....	17
3.1	Test Setup and Definition of Standard Discharge Profile (SDP)	17
3.2	Process to Charge the DUT	17
3.3	Determination of When the DUT Turns Off	17
3.4	Determination of Total Available Energy - Measurement Procedure	17
3.5	Connected Test Mode	18
3.6	Procedure to Calculate TAE	18
3.7	Procedure to Handle Multiple Cell Vendors or Battery Packs	18
Section 4	Energy Use per Activity	19
4.1	Test Setup and Test Cases	19
4.2	Determination of Energy Use per Activity.....	19
4.2.1	Gaming	20
4.2.2	Compose, Send, Receive, Read SMS Message.....	22
4.2.3	Compose, Send, Receive, Read Email Message	25
4.2.4	Home Screen Display On	28

4.2.5	Audio Streaming/Music Playback	29
4.2.6	Video Streaming	30
4.2.7	Voice Call	30
4.2.8	Web Browsing.....	32
4.2.9	Standby	32
4.2.10	Location Services	32
Section 5	Energy Use per Activity – MIoT	34
5.1	Test Setup and Test Cases	34
5.2	Network Parameters – NB-IoT	34
5.3	Network Parameters – Cat-M	35
5.4	Determination of Energy Use per Activity	35
5.4.1	Power Saving Mode.....	35
5.4.2	Standby	36
5.4.3	Active Mode	38
Section 6	User Profiles	39
6.1	Definition of User Profiles	39
Section 7	Battery Life Rating	40
7.1	Calculation of Battery Life Rating	40
Appendix A	DUT Configuration During Testing (for both TAE and Energy Use Per Activity).....	41
Appendix B	Network Simulation for NR Testing	43
B.1	5G NR Band Combinations	43
B.2	General Cell Settings for LTE+NR NSA	44
B.3	NR Cell Settings for NSA Download Tests (Browsing, Streaming and E-mail).....	46
B.4	NR Cell Settings for NSA Upload Tests (Send Email)	46
B.5	NR General Cell Settings for SA Testing.....	47
B.6	NR Cell Settings for SA Download Tests (Browsing, Streaming and Email)	48
B.7	NR Cell Settings for SA Upload Tests (Send Email)	48
B.8	Test Requirement in LTE and NR	50
Appendix C	Revision History	51

List of Figures

Figure 2.3-1 Preferred Picture to Use For The Brightness Testing	11
Figure 3.1-1 SDP Test Setup	17
Figure 4.1-1 Energy Use Per Activity Test Setup	19
Figure 4.2-1 VoLTE Test Setup	31

List of Tables

Table 1.5-1 Acronyms and Definitions	7
Table 2.5-1 LTE/5G NR Transmit Power Distribution Profile.....	12
Table 2.5-2 Preferred Frequency Bands for Testing	12
Table 2.7-1 DUT Configuration Prior to Testing.....	13
Table 2.10-1 Power Supply	14
Table 2.10-2 Analyzer	15
Table 4.2-1 Test Case Procedure Reference.....	20
Table 5.2-1 NB-IoT Network Settings	34
Table A-1 DUT Configuration During Testing	41
Table B.1-1 5G NR SA Band Combinations and NSA Bands per Operator	43
Table B.2-1 General Cell Settings for LTE+NR NSA.....	44
Table B.3-1 NR Cell Settings for NSA Download Tests	46
Table B.4-1 NR Cell Settings for NSA Upload Tests	46
Table B.5-1 NR General Cell Settings for SA Testing	47
Table B.6-1 NR Cell Settings for SA Download Tests	48
Table B.7-1 NR Cell Settings for SA Upload Tests.....	48
Table B.8-1 Test Requirement in LTE and NR	50

Section 1 Introduction

1.1 Purpose

The purpose of this test plan is to define the CTIA Certification Program requirements for testing and determining the expected battery life of smartphones and smartwatches.

1.2 Scope

This document makes use of the GSM Association document *TS.09 [2]*: Battery Life Measurement and Current Consumption Technique. Additional considerations and requirements are outlined in this test plan.

All tests are conducted in LTE, except when the DUT does not support VoLTE and in that case, voice calls are conducted in WCDMA.

1.3 Reference Documents

The following documents are referenced in this test plan:

[1]	<i>Battery Life Certification Program</i> , Latest Revision, CTIA Certification
[2]	<i>TS.09: Battery Life Measurement and Current Consumption Technique</i> , Version 10.1, GSM Association
[3]	<i>TS 36.521-1: Technical Specification Group Radio Access Network; Evolved Universal Terrestrial Radio</i>
[4]	<i>Access (E-UTRA); User Equipment (UE) conformance specification Radio transmission and reception; Part 1: Conformance Testing</i> , Latest Revision, 3GPP
[5]	<i>TS 44.014: Technical Specification Group GSM/EDGE Radio Access Network; Individual equipment type requirements and interworking; Special conformance testing functions</i> , Latest Revision, 3GPP
[6]	<i>S 34.109: Technical Specification Group Radio Access Network; Terminal logical test interface; Special conformance testing functions</i> , Latest Revision, 3GPP
[7]	<i>TS 36.509: Technical Specification Group Radio Access Network; Evolved Universal Terrestrial Radio Access (E-UTRA) and Evolved Packet Core (EPC); Special conformance testing functions for User Equipment (UE)</i> , Latest Revision, 3GPP
[8]	<i>TS 36.508: Technical Specification Group Radio Access Network; Evolved Universal Terrestrial Radio Access (E-UTRA) and Evolved Packet Core (EPC); Common test environments for User Equipment (UE) conformance testing</i> , Latest Revision, 3GPP

1.4 Test Process

All testing shall be conducted at a CTIA Certification Authorized Test Lab (ATL). A current list of ATLs can be found at <https://ctiacertification.org>. Devices shall be submitted for testing in accordance with the instructions detailed in the CTIA Certification document *Battery Life Certification Program [1]*.

1.5 Acronyms and Definitions

Table 1.5-1 Acronyms and Definitions

Acronym/Term	Definition
ABC	Adaptive Brightness Control
AP	Access Point
APN	Access Point Name
Battery/Battery Pack	An assembly of any number of Li-Ion or Li-Ion Polymer cell(s), associated electronics, battery packaging and connector(s).
Camped	DUT has registered with the network and is in idle mode, waiting to be paged
ATL	CTIA Certification Authorized Testing Laboratory
cDRX	Connected Mode DRX
Cell	Basic manufactured Li-Ion or Li-Ion Polymer unit providing a source of electrical energy by direct conversion of chemical energy that consists of electrodes, separators, electrolyte, container and terminals, and that is designed to be charged electrically.
CS	Circuit Switched
DRX	Discontinuous Reception
DUT	Device Under Test
eDRX	Extended DRX
E-UTRA	Evolved Universal Terrestrial Radio Access
Forget/delete AP	The registration from an AP is deleted resulting in the DUT returning to state 'Wi-Fi on, no AP'
GNSS	Global Navigation Satellite System
GPS	Global Positioning System
GSM	Global System for Mobile Communications
IMS	IP Multimedia Subsystem
Iteration	A measurement of average current drain of the activity defined by the test case
LTE	Long Term Evolution
LTE-M	Long Term Evolution for Machines

Acronym/Term	Definition
LUX	A figure used to represent illuminance and luminous emittance expressed in lumen per square meter
MCS	Modulation Coding Scheme
MloT	Mobile Internet of Things
NB-IoT	Narrowband Internet of Things
NITS	A figure used to represent luminance expressed in candela per square meter
NR	5G New Radio
PSM	Power Saving Mode
RAT	Radio Access Technology
RRC	Radio Resource Control
RS EPRE	Reference Symbol Energy Per Resource Element
RTSP	Real Time Streaming Protocol
SDP	Standard Discharge Profile
SG-SMS	SMS over SGs
Smartphone	A mobile phone built on a mobile operating system that includes, among other capabilities, Internet access, applications, email and camera.
Smartwatch	A watch built on a mobile operating system that includes, among other features, the capability to directly access a mobile cellular network without the use of a Smartphone.
SMS	Short Message Service
TAE	Total Available Energy
TBS	Transport Block Size
VoLTE	Voice over LTE
WCDMA	Wideband Code Division Multiple Access
Wi-Fi disabled	The Wi-Fi radio is turned off
Wi-Fi enabled, device connected to AP	Wi-Fi is on, connected and registered to an AP. Access to the Public Internet is available
Wi-Fi enabled, no AP	Wi-Fi is on. DUT is searching for an AP. No connection to the Public Internet is available

Section 2 Test Conditions and Generic Setup

2.1 Ambient Test Conditions

The ambient conditions, including the display configuration, shall be followed for all tests.

2.2 Temperature

Testing shall be performed at ambient temperature: 23 ± 5 °C.

2.3 Display Settings

The ATL should verify whether the DUT supports Adaptive Brightness Control (ABC) and if it is enabled or disabled by default (i.e. after a factory reset of the DUT).

In the DUT Details document, the manufacturer shall also declare the default DUT brightness configuration and the figure of candelas per meter squared (NITS) to the ATL. For DUTs supporting ABC, and enabled by default, the NITS figure must be based on the DUT's response in ambient light conditions of 300 LUX.

The ATL shall measure and record the NITS level and brightness setting in the test report. The NITS measurements made by the ATL must be within 10% of that declared by the manufacturer.

If the ATL is not able to confirm the information provided by the manufacturer, the manufacturer shall work with the ATL to resolve the issue or submit another set of brightness setting values. If the manufacturer does not resolve these issues with the ATL then the DUT will be rejected by the ATL.

Devices with ABC not supported or disabled by default.

For DUTs that do not support ABC, or ABC is supported but disabled by default, the brightness setting used throughout testing shall be the default setting (i.e. after a factory reset). The brightness setting used shall be recorded in the DUT Details document.

Devices with ABC supported and enabled by default.

The objective with this DUT configuration is to identify what the screen output setting (in NITS) would be with ABC enabled in an ambient lighting condition of 300 LUX. The ABC will then be disabled and the DUT screen output will be adjusted until the same Screen Brightness is measured in NITS is achieved. The screen setting will be noted as a percentage of max and this is used throughout testing.

This is required to ensure that all testing is performed with the same default screen brightness irrespective of any change in the ambient lighting conditions.

STEP ONE: Measure the ambient lighting using an Illuminance Meter.

1. Tests shall be conducted in a room with an adjustable light intensity or dimmer or a lamp fixture with a voltage regulator.
2. The ambient light values (LUX) is measured at the location of the ABC sensor on the DUT with light entering directly into the sensor. This can be achieved by placing the light meter directly above the ABC sensor or place the light meter at the same location where the DUT will then be placed for testing.

Note: in the case of some Lux meters, it may be required to setup the illuminance meter for the type of ambient lighting e.g. Tungsten, Fluorescent, etc.

3. The room or lamp fixture light intensity is adjusted until 300 LUX is measured on the Illuminance Meter.

STEP TWO: Measure the Screen Brightness with ABC enabled and under the 300 LUX conditions, achieved above, and using a Luminance Meter.

1. Ensure any screen protector film is removed and the screen free from any marks or dust (i.e. fingerprints, smudges, etc.).
2. Display Test Image as per [Figure 2.3-1](#) on the DUT screen for about 10 minutes.
3. The ATL test operator shall target the center of the white area with the Luminance Meter during this test step and record the NITS measured.
 - a. The measurement distance may vary depending on the type of meter and lenses.
 - b. For contact type meters, no dark room conditions are required for measurement.
 - c. For non-contact type meters, dark room conditions are required for the measurement.

Note: Be careful that nothing casts a shadow over the ABC sensor when taking the measurement (i.e. the Luminance meter), as the DUT's sensor will detect less than 300 Lux and adjust the screen output accordingly.

STEP THREE: Disable ABC and, using the DUT control, adjust the Screen Brightness until the NITS value measured above with the Luminance Meter is reached and making a note of the setting (normally a number or a percentage).

The ATL shall verify the measured figure is within 10% of the manufacturer-declared NITS figure.
The setting used for the Test Plan is the one measured by the ATL.

The ATL shall use a standardized picture for this procedure that will appear on the DUTs Screen. The picture shall be such that surface-area-wise it covers 70% of the display in black color and 30% of the display in white color. The interior section shall be white while the exterior section shall be black. The measurement shall be made in the white area only.

The preferred picture to use for the brightness testing is shown in [Figure 2.3-1](#). The intent of the standardized picture is that it represents a white color of 255, 255, 255 and black color of 0, 0, 0 [RGB].

The picture in [Figure 2.3-1](#) is for devices with a 16:9 aspect ratio. For displays with different aspect ratios, another picture may be used but it must fulfill the 70% black and 30% white criteria.

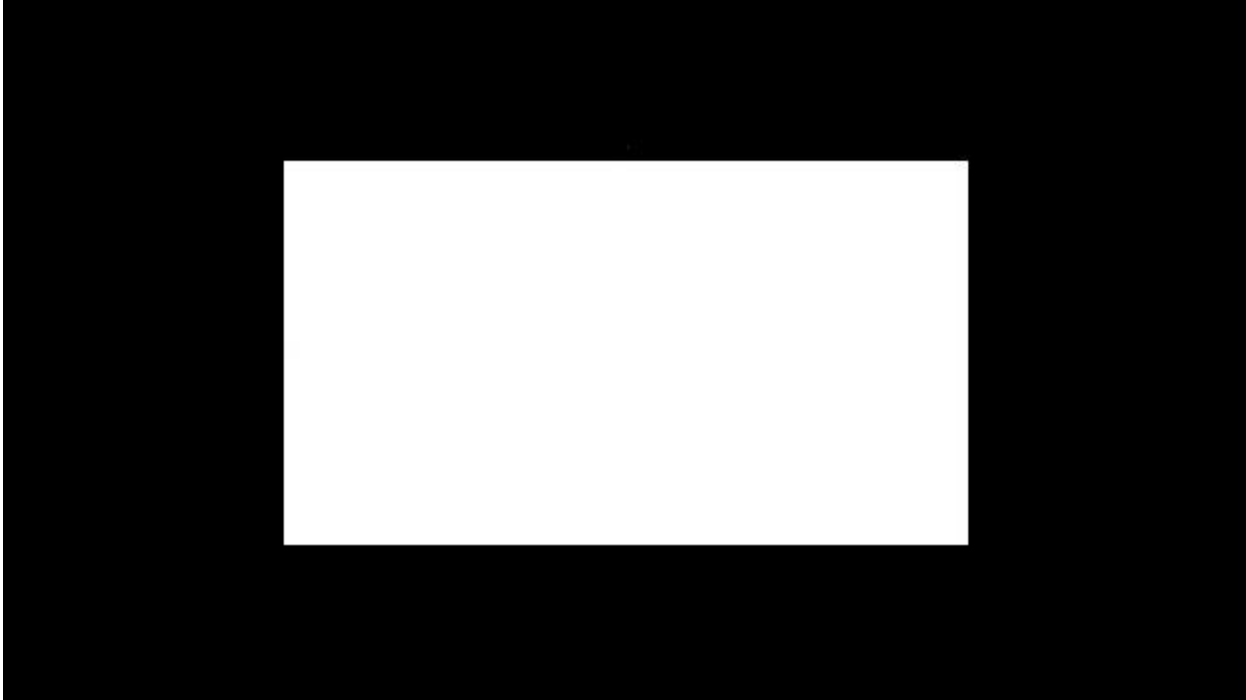

Figure 2.3-1 Preferred Picture to Use For The Brightness Testing

2.4 Test Case Procedures

Unless otherwise specified in this document, the test case procedures are specified in *GSMA TS.09 [2]*.

2.5 RF Parameters

Except where specified in this section, the RF parameters shall be as defined in *GSMA TS.09 [2]* for WCDMA and LTE devices.

For LTE test cases, the parameters found in *GSMA TS.09 [2]* for E-UTRA standby shall be used. Additionally, RS EPRE level of -85dBm/15kHz shall be used, in alignment with *3GPP TS 36.521-1 [3]*. Per Table 21 for download use case in *GSMA TS.09 [2]*, for 10MHz BW allocation, web browsing, video streaming, audio streaming, and email test cases shall use 1 uplink resource block and 12 downlink resource blocks. The TBS shall be set to 19 on the downlink and 20 on the uplink. (MCS: 21 for downlink and 22 uplink).

CQI reporting shall be enabled and the simulator will follow the RI reported by the DUT in respect to handling of the Diversity Port.

In the case where cDRX settings are specified, Dynamic Uplink Scheduling shall be used.

In addition, an IMS server shall be available at all times for IMS Registration if and when required by the DUT as a feature of the SIM card used.

The RRC inactivity timer shall be set to 10 seconds.

For LTE/5G NR transmit power, the profile defined in [Table 2.5-1](#) shall be used.

Table 2.5-1 LTE/5G NR Transmit Power Distribution Profile

+24dBm	+18 dBm	+8 dBm	+2 dBm	-20 dBm
24.66%	35.75%	27.66%	4.98%	6.95%

During the LTE/5G NR test cases, the transmit power profile will be distributed over the test time to meet the distribution percentages defined in [Table 2.5-1](#). This defines the % of test time that the DUT transmits at a particular output power level. Additionally, the transmit power profile will start at the lowest power level defined and increase towards the maximum defined transmit power in order to mitigate any heating concerns. For WCDMA, only the power profile measurements are required, but not the fixed Tx RF power level).

A fixed power level of +10dBm shall be used for all tests where the test description does not indicate the use of a transmit power profile.

[Table 2.5-2](#) defines the preferred frequency bands for testing the DUT.

Table 2.5-2 Preferred Frequency Bands for Testing

Operator	LTE	WCDMA
AT&T	12/17	2
T-Mobile	66	2
Verizon	13	N/A

If the DUT Details document indicates the DUT does not support MIMO, then SISO configuration shall be used with Transmission Mode 1 (TM1).

2.6 Sampling Rate

The physical sampling frequency for current drain measurement for all test cases shall be a minimum of 50k samples per second.

2.7 DUT Configuration Prior to Testing

When possible, the DUT shall be factory reset prior to the start of testing. Instructions on how to set up the DUT prior to testing shall be found in the DUT Details document, completed by the manufacturer. This includes whether the DUT needs access to a Wi-Fi connection in order to download any updates. If Wi-Fi is used to download game, application, music file or other, then the Wi-Fi AP connection is to be forgotten/deleted prior to execution of any test. The Wi-Fi shall then be enabled or disabled, depending on how the DUT is to be configured by default. GPS/location-based services shall be enabled on the DUT.

After the DUT has been factory reset and setup, the DUT shall be powered on and allowed to settle for a duration which is specified by the manufacturer.

Unless explicitly specified:

- The default audio settings shall be used for all tests.
- The DUT's orientation shall be Portrait.
- The Headset should not be used.
- Where a headset is specified, and the device does not have an audio plug or any default headset, an off-the-shelf Bluetooth audio device shall be used.

All notification settings shall be set to the default state.

The ATL shall indicate in the DUT Details document the DUT configuration used. The DUT configuration prior to testing is described in [Table 2.7-1](#).

Table 2.7-1 DUT Configuration Prior to Testing

Test Case	Comments
Music Playback	Copy the music source file to the DUT. These may be copied to the DUT hard drive if you have OEM-provided USB drivers. Per the <i>GSMA TS.09</i> [2], download the reference music file from the GSMA website and store it onto the DUT.
Compose, Send, Receive, Read Email Message	Install the K-9 Mail application, latest version, from the online store. Document the version installed in the test report. The default settings of the K-9 Mail application shall be used, unless otherwise noted in this Test Plan
Gaming	Install Angry Birds game or Catapult Quest.
Compose, Send, Receive, Read SMS Message	Create one unique contact in the default messaging client.

2.8 DUT Wait Time Before Testing

For all tests, the ATL test operator shall wait a minimum of 5 minutes after activation for DUT boot processes to be completed. If the DUT was not rebooted, the 5 minutes wait time can be skipped.

2.9 DUT Configuration During Testing

See [Appendix A](#) for the DUT configuration to be used during testing.

It is acceptable for multiple devices to be used for the purposes of completing this Test Plan if deemed necessary by the ATL. This may be required in the case where components have to be removed/adapted for the purposes of performing different aspects of the Test Plan. An example of this is where physical changes are necessary to provide access to either a Live or Dummy Battery.

The reasons for different devices should be outlined to the ATL by the OEM.

2.10 Power Supply and Analyzer

[Table 2.10-1](#) and [Table 2.10-2](#) merge settings specified within GSMA TS.09 and provide the additional requirements for stability and accuracy.

It should be noted that the current validated Power Analyzer meets these requirements.

Table 2.10-1 Power Supply

Parameter	Requirement	Comments
Range	Nominal Voltage of device	Additional headroom to compensate for any cabling losses
Resolution	$\leq 10\text{mV}$	
Deviation	$\leq 10\text{mV}$	
Temporary Voltage Drop	60mV	Transient Voltage drop as a result of transient loads
Recovery/Settling Time	50uS	Time to recover to within 30 mV of the final voltage value following a load current transient
Current Source	The DC source should have sufficient output current capability, both continuous and peak, to adequately supply the MS during all measurements.	Current limiting of the power supply shall not function during a measurement
Sense Lines	Remote sensing to allow the effects of resistance of the supply cables to be compensated for, and to allow maintenance of the nominal voltage at the MS battery terminals	Should be connected as close as possible to the device under test

Table 2.10-2 Analyzer

Parameter	Requirement	Comments
Measurement Resistance	≤ 0.1 Ohms	
Sampling Frequency	≥ 50 ksps	Measurement shall be continuous
Voltage Measurement Range	4.5V to 2.5V	
Voltage Resolution	1mV	
Voltage Deviation	0.3%	Of measured value across Voltage Measurement Range
Current Resolution	≤ 0.1 mA Idle Mode ≤ 0.5 mA Dedicated Mode	
Current Deviation	2%	Of measured value across full operating range of the device under test
Noise floor	Less than the lowest ADC step	

2.11 Wearables

In the case of wearable devices, the following details also apply.

2.11.1 Smartwatches

The following settings shall supersede all other DUT settings specified for the DUT.

- The DUT will not be paired with a smartphone while performing testing.
- The Display will be the default as shipped 'out-of-the-box'.

2.12 SIM Cards

The ATL shall use a SIM card supplied, or specified, by the Operator. Details of the SIM used shall be recorded in the DUT Details document.

The ATL shall ensure the Network Simulator is configured, according to the SIM card used, to simulate the Home PLMN (HPLMN) and not Roaming.

The APN on the SIM card supplied by the operator shall be used. If the SIM card does not contain an APN, then the Operator should supply the details required to enter in the DUT.

If the DUT uses an eSIM, then the OEM will provide the eSIM preconfigured as per the Operator's requirements or provide details to the ATL on configuring the eSIM after a full reset.

2.13 GNSS Simulator

For all tests of [Section 4](#) and [Section 5](#), if the DUT supports GPS location based services, a GNSS Simulator should be used throughout.

The Simulator should be connected to the DUT, with a static GPS scenario playing for the duration of the test. In the case of MIoT trackers, a dynamic scenario should be used.

The approved scenarios will be provided by the authorized test system vendors.

Section 3 Total Available Energy

3.1 Test Setup and Definition of Standard Discharge Profile (SDP)

A battery will be used for the determination of Total Available Energy (TAE). In order to determine the TAE, simultaneous measurements of voltage and current are performed until the DUT switches off.

The SDP procedures require the capability to measure both instantaneous current and voltage. Using a sense resistor circuit is not an acceptable solution for this process because that requires the measurement of two voltage signals.

See [Figure 3.1-1](#) for the test setup.

On completion of the test, average current, voltage and energy will be calculated (per the procedure described in [Section 3.6](#)) and the test time will be made available. The TAE shall be recorded in the test report, along with the average current and average voltage.

The average voltage measured in this section of the test plan will be used as the fixed voltage setting in [Section 4](#).

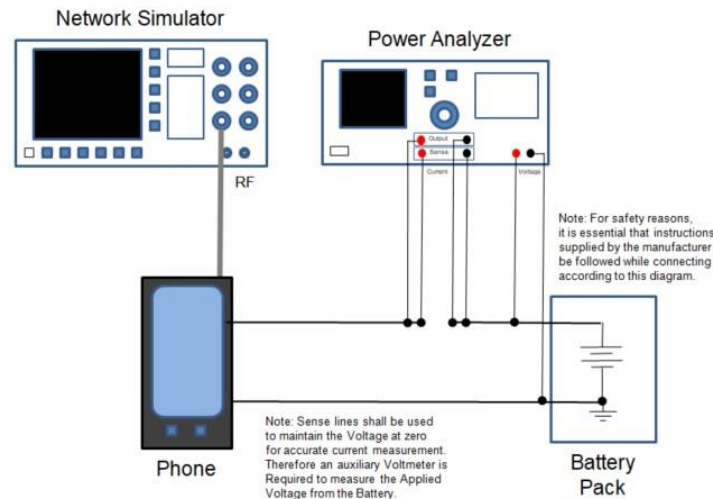

Figure 3.1-1 SDP Test Setup

3.2 Process to Charge the DUT

The process to charge the DUT shall be defined by the manufacturer in the DUT Details document.

3.3 Determination of When the DUT Turns Off

The process to determine when the DUT has turned off shall be defined by the manufacturer in the DUT Details document.

3.4 Determination of Total Available Energy - Measurement Procedure

Fully Charge the battery using the DUT and following the manufacturer charging instructions stated in the DUT Details document, using the manufacturer-specified charger.

Connect the fully charged battery with the analyzer so that both instantaneous current and instantaneous voltage measurements can be performed.

Activate the network simulator in the desired RAT. - All testing will be performed the Appendix B.8 supported by the DUT.

Switch the DUT on and start the instantaneous voltage and instantaneous current measurements. Wait for the DUT to register with the simulator.

Place the DUT in the appropriate Connected Test Mode State.

Continue performing the measurements until the DUT has powered off per the DUT Details document.

Stop the measurement and record the time, average voltage, current and calculate the usable battery capacity and the TAE (per the process defined in Section 3.6).

Throughout the measurement, the Uplink DUT Power shall be continuously changed according to the Power Distribution Profile specified for the used RAT as defined in Section 2.5. The Power Distribution Profile shall be repeated in 10-minute cycles for the SDP portion of the testing.

3.5 Connected Test Mode

Test Modes are defined in the core specifications to allow for testing data connections with no requirement for any U-Plane connection (i.e. no Application Layers). These Test Modes are defined for WCDMA (3GPP 34.109 [6]) and LTE (3GPP 36.509 [7], 36.508 [8]).

3.6 Procedure to Calculate TAE

The current drain figures from Section 3.4 shall be multiplied by the voltage figures for every measurement sample to calculate the instantaneous power. That instantaneous power shall be integrated over the entire data set by using the integration time period in order to calculate the TAE from the battery and the DUT. The figure that is derived is the TAE and this figure shall be recorded in the test report in mWh.

3.7 Procedure to Handle Multiple Cell Vendors or Battery Packs

In the instance where the DUT manufacturer submits more than 1 battery pack vendor or there is more than 1 cell vendor, then the TAE for all the different cell and pack vendor combinations shall be measured for TAE and average voltage. All the TAE figures shall be reported by the ATL. The lowest TAE measured AND the associated measured average voltage from the different cells and pack combinations shall be used in the customer profile calculation spreadsheet to determine the estimated hours of operation.

Section 4 Energy Use per Activity

4.1 Test Setup and Test Cases

Testing shall be performed per *GSMA TS.09* for all test cases where test procedures are defined, as noted in [Table 4.2-1](#). For Smartwatches, a test case shall be performed only if the DUT supports that activity as defined by the OEM in the DUT Detail Document. If a test case is omitted the tester must update the “Duration Per Day (min)” column in the Sample Profile Calculation Template to “0” to reduce its weight against the Battery Life figure.

Test cases and procedures not defined in the *GSMA TS.09* [2] document are specified here.

The average voltage figure which was recorded in [Section 3](#) will be used as the fixed voltage setting in this section of the test plan. It is required that the dummy battery shall have sense line connections. The standby time test case shall be preceded by rebooting the DUT and waiting for the required settling time prior to performing that test.

See [Figure 4.1-1](#) for the test setup.

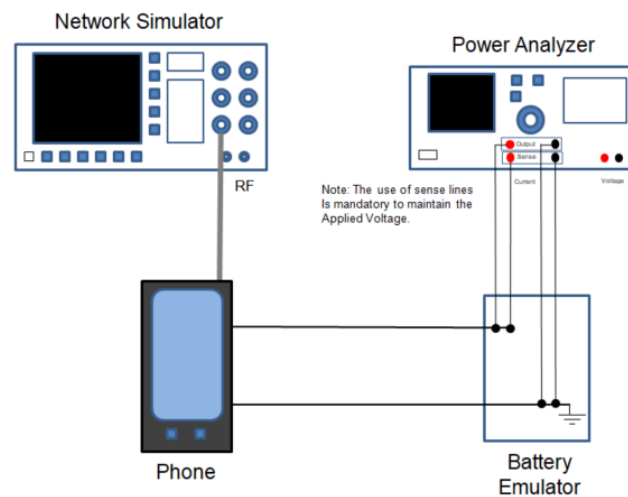

Figure 4.1-1 Energy Use Per Activity Test Setup

4.2 Determination of Energy Use per Activity

In order to determine the energy use per activity, current drain measurements shall be performed. A dummy battery shall be used for all energy use per activity items. The current drain shall be used, along with the voltage, to determine overall power consumed by these activities.

The current drain (I) and the voltage (V) figures shall be recorded in the test report for each test case. The power consumed per activity shall be calculated using the formula $P = V * I$. The power consumed by each activity shall be recorded in the test report and shall be used in [Section 6.1](#).

If possible, prior to testing, the ATL test operator shall confirm that there is no current drain due to the dummy battery being connected to the power supply while the DUT is not connected. Current drain measurements shall be performed on the following list of activities. The power consumed for each activity shall be determined based on the current drain measurements for each individual activity. Then, the power consumed shall be converted to a figure of energy. The energy used for the different activities shall be subtracted from the TAE figure from [Section 3.6](#).

Conduct the tests indicated in Appendix B.8 according to the network technology requested by the Operator.

Table 4.2-1 Test Case Procedure Reference

Section	Test Case	Refer To GSMA TS.09 For Test Procedures	Refer to this Document for Test Procedures	Applicability	
				Smartphone	Smartwatch
4.2.1	Gaming		X	X	
4.2.2.1	Compose SMS Message		X	X	
4.2.2.2	Send SMS Message		X	X	
4.2.2.3	Receive SMS Message		X	X	X
4.2.2.4	Read SMS Message		X	X	X
4.2.3.1	Compose Email Message		X	X	
4.2.3.2	Send Email Message		X	X	
4.2.3.3	Receive Email Message		X	X	
4.2.3.4	Read E-mail Message		X	X	
4.2.4	Home Screen Display On		X	X	X
4.2.5.1	Audio Streaming	X		X	X
4.2.5.2	Music Playback	X		X	X
4.2.6	Video Streaming	X		X	
4.2.7	Voice Call	X		X	X
4.2.8	Web Browsing	X		X	
4.2.9	Standby	X		X	X
4.2.10	Location Services		X	X	X

4.2.1 Gaming

The purpose of this test is to measure the power consumed while performing gaming activities.

Test Setup:

- No Internet connection shall be available for this test case.

DUT Configuration:

- For the gaming test case, the DUT shall be set to Airplane/Flight mode.
- Connect manufacturer-provided headset to the DUT's audio headset socket and set Headset Volume to DUT default setting.
- Download and install the latest version of the Angry Birds Mobile App or Catapult Quest Mobile App.
- The version of the Angry Birds application or Catapult Quest application shall be recorded in the test report.
- Open Angry Birds or Catapult Quest. Note: if the game does not run, then it will be necessary to connect the Application to the Server to progress to the menus. To achieve this, change the Wi-Fi state to Wi-Fi enabled, device connected to AP and relaunch the game. Once the game has launched then forget/delete the AP and set the Wi-Fi to the default state as per [Appendix A](#).
- Display shall be ON and in landscape mode during the entire duration of this test

Test Procedure:**Angry Birds:**

- Open Angry Birds, go to the "Play" sign, select "Poached Eggs", select the First Level, and fast forward the preview screen to get to the game ready mode.
- Play the game by launching each of the 3 birds at the 5, 10 and 15 second time mark of every 20 second interval of gameplay. Launch the birds to the opposite side (Left Side) of the target so it DOES NOT hit the target pigs. After the game is failed, select "Replay" to repeat the same level with the same procedure. Play the same level 6 times. Pace yourself to use approximately 20 seconds for each round of the game.

Catapult Quest:

- Open Catapult Quest, select the First Level, and fast forward the preview screen to get to the game ready mode.
- Play the game by launching each of the 3 monkeys at the 5, 10 and 15 second time mark of every 20 second interval of gameplay. Launch the monkeys to the opposite side (Left Side) of the target so it DOES NOT hit the target construction. After the third monkey has been launched and as soon as the fourth monkey is loaded into the catapult, click the "Pause" icon on the top right. Select "Retry" level to repeat the same level with the same procedure. Play the same level 6 times. Pace yourself to use approximately 20 seconds for each round of the game.
- The ATL test operator shall manage the time properly during the measurement of game play.
- Begin the current drain measurement and immediately begin game play, following the previously given guidelines.

- If during gameplay the ATL test operator is offered an upgrade, assistance, pop-up box or other similar disruption, the message/upgrade shall be acknowledged/dismissed, that data shall be thrown out, and that iteration shall be run again.
- The test equipment will stop the current drain measurement after 2 minutes. This represents one iteration of the data.
- Record the average current drain measurement for the test.
- Run this test for a total of 5 iterations and average the results.
- Calculate the average power consumed for this activity.

4.2.2 Compose, Send, Receive, Read SMS Message

Options:

Until this document specifies the configuration which is required to send SMS over IMS for each network operator SG-SMS shall be used.

4.2.2.1 Compose SMS Message

The purpose of this test is to measure the power consumed to compose a single SMS message 60 bytes in length.

Test Setup:

- Mobile data shall be turned off.
- DUT shall be camped to the simulator with the display ON.
- DUTs support a variety of different text messaging applications. The default messaging application shall be used for this test.
- The default SMS application shall be set up to add 1 recipient prior to testing. The default SMS application shall be opened with recipient information filled out and cursor positioned for message- body text entry.
- The ATL test operator shall not use the text auto correction feature, or the text auto completion feature, on the DUT, if possible.

Test Procedure:

- Begin measuring current drain (do not let display timeout before starting measurement).
- Type 60 characters at a rate of 2 characters per second for 30 seconds until the test stops. Any two alternating characters may be used for this test. The test equipment will stop the current drain measurement 30 seconds after the measurement started. This represents one iteration of the data.
- Record the average current drain measurement for the test.
- Run this test for a total of 5 iterations and average the results.
- Calculate the average power consumed for this activity

4.2.2.2 Send SMS Message

The purpose of this test is to measure the power consumed to send a single SMS message 60 bytes in length.

Test Setup:

- DUT shall be camped to the simulator with the display ON.
- DUTs support a variety of different text messaging applications. The default messaging application shall be used for this test.
- The default SMS application shall be set up to add 1 recipient prior to testing. The default SMS application shall be opened with recipient information filled out and cursor positioned for message- body text entry.
- Enter 60 characters of text: “Are you going to the party tonight? I will be there at eight” in the message body.
- Mobile data shall be turned off.

Test Procedure:

- Begin measuring current drain (do not let display timeout before starting measurement).
- Press the send icon to send the text: “Are you going to the party tonight? I will be there at eight” in the message body.
- Send the text to whatever number is required by the network simulator/test script.
- The test equipment will stop the current drain measurement 15 seconds after the measurement started. This represents one iteration of the data.
- Record the average current drain measurement for the test.
- Run this test for a total of 5 iterations and average the results.
- Calculate the average power consumed for this activity

4.2.2.3 Receive SMS Message

The purpose of this test is to measure the power consumed to receive a single SMS message 60 bytes in length.

Test Setup:

- DUT shall be camped to the simulator with the display off.
- DUTs support a variety of different text messaging applications. The default messaging application shall be used for this test.
- On a network simulator, open a test message application and fill out the recipient information for sending a message to the DUT. Enter 60 characters of text: “Are you going to the party tonight? I will be there at eight” in the message body but do not yet send the text.

- Mobile data shall be turned off.

Test Procedure:

- Begin measuring current drain.
- Send text from the network simulator to the DUT.
- DO NOT touch/wake the DUT.
- The test equipment will stop the current drain measurement 30 seconds after the measurement started. The ATL test operator shall confirm that the text is in the inbox of the DUT AFTER the measurement has stopped. This represents one iteration of the data.
- Record the average current drain measurement for the test.
- Run this test for a total of 5 iterations and average the results.
- Calculate the average power consumed for this activity.

4.2.2.4 Read SMS Message

The purpose of this test is to measure the power consumed to read a single SMS message 60 bytes in length.

Test Setup:

- DUT shall be camped to the simulator with the display ON.
- DUTs support a variety of different text messaging applications. The default messaging application shall be used for this test.
- On a network simulator, open a test message application and fill out the recipient information for sending a message to the DUT. Enter 60 characters of text: "Are you going to the party tonight? I will be there at eight" in the message body but do not yet send the text.
- Send 5 texts to the DUT such that the default text application has 5 or more text threads. This means that there are 5 different senders sending text messages to the DUT.
- Mobile data shall be turned off.
- The default SMS application shall be opened.
- If the DUT does not support a back or return feature, then an alternative method can be used to move to the next message. The tester will record their alternate method in the test report.

Test Procedure:

- Begin measuring current drain.
- At the 10 second time mark, read the SMS by clicking the first unread message in the inbox.

- You will have 9 seconds to read the message before having to press the "back" or "return" button to return to the inbox and 1 second after to press the next unread message to open it. This will be repeated for the duration of the test.
- Press the "Back" or "Return" at the 19, 29, 39, and 49 second time mark, and open the next unread message at the 20, 30, 40, and 50 second time mark.
- The test equipment will stop the current drain measurement 60 seconds after measurement was started. This represents one iteration of the data.
- Record the average current drain measurement for the test.
- Run this test for a total of 5 iterations and average the results.
- Calculate the average power consumed for this activity

4.2.3 Compose, Send, Receive, Read Email Message

4.2.3.1 Compose Email Message

The purpose of this test is to measure the power consumed to compose a single email message 60 bytes in length.

Test Setup:

- DUT device shall be camped to the simulator with the display ON.
- Mobile data shall be turned off.
- The K-9 Mail application shall be set up to add 1 recipient prior to testing.
- The K-9 Mail application shall be opened with recipient information filled out and cursor positioned for message-body text entry.
- The ATL test operator shall not use the text auto-correction feature, or the text auto-completion feature, on the DUT, if possible.

Test Procedure:

- Begin measuring current drain (do not let display timeout before starting measurement).
- Type 60 characters at a rate of 2 characters per second for 30 seconds until the test stops. Any two alternating characters may be used for this test.
- The test equipment will stop the current drain measurement 30 seconds after measurement started. This represents one iteration of the data.
- Record the average current drain measurement for the test.
- Run this test for a total of 5 iterations and average the results.
- Calculate the average power consumed for this activity

4.2.3.2 Send Email Message

The purpose of this test is to measure the power consumed to send a single email message 60 bytes in length.

Test Setup:

- DUT device shall be camped to the simulator with the display ON.
- The K-9 Mail application shall be set up to add 1 recipient prior to testing.
- The K-9 Mail application shall be opened with recipient information filled out and cursor positioned for message-body text entry.
- Enter 5 characters of text: "Party" in the subject line of the email header.
- Enter 60 characters of text: "Are you going to the party tonight? I will be there at eight" in the message body.
- Ensure any auto signature is disabled or deleted from the message body.

Test Procedure:

- Begin measuring current drain (do not let display timeout before starting measurement).
- Press the send icon to send the email message.
- Send the email to whatever email address is required by the network simulator/test script.
- The test equipment will stop the current drain measurement 15 seconds after the measurement started. This represents one iteration of the data.
- Record the average current drain measurement for the test.
- Run this test for a total of 5 iterations and average the results.
- Calculate the average power consumed for this activity

4.2.3.3 Receive Email Message

The purpose of this test is to measure the power consumed to receive a single email message 60 bytes in length.

Test Setup:

- Note: Due to the short measurement time of this test, it is required that only the measurement of the email activity should be recorded so there is no significant impact on the overall measurement. If, during the test, another application receives an update or performs an activity in the background, then the result should be discarded and the test repeated.
- DUT shall be camped to the simulator with the display off.
- DUTs support a variety of different email messaging applications. The K-9 Mail messaging application shall be used for this test.

- The DUT should start this test case in idle mode.
- The test shall be executed in such a way that the DUT push settings (synch schedule) shall be configured such that the DUT will immediately fetch the email once it receives a notification.
- On a network simulator, open a test email message application and fill out the recipient information for sending an email message to the DUT. Enter "Party" as the subject of the email header. Enter 60 characters of text: "Are you going to the party tonight? I will be there at eight" in the message body but do not yet send the email message. As only 60 characters shall be entered as the content of the email, any auto signature should be disabled on the test email message application or deleted if present.

Test Procedure:

- K-9 Mail application will be killed (force stop or clear all applications for example) before testing.
- RRC idle state should be the initial condition.
- The ATL test operator shall push home screen icon (e.g. house, circle) one time in order to set the DUT to the home screen.
- Begin measuring current drain.
- Send email message from the network simulator the DUT.
- Wait a total of 30 seconds for the email to be received but DO NOT touch/wake the DUT.
- The test equipment will stop the current drain measurement 30 seconds after measurement was started. This represents one iteration of the data.
- The ATL test operator shall confirm receipt of the email message by verifying that the email is in the DUT inbox AFTER the measurement has stopped.
- Record the average current drain measurement for the test.
- Run this test for a total of 5 iterations and average the results.
- Calculate the average power consumed for this activity

4.2.3.4 Read E-mail Message

The purpose of this test is to measure the power consumed to read a single email message 60 bytes in length.

Test Setup:

- DUT shall be camped to the simulator with the display ON.
- On a network simulator, open a test email message application and fill out the recipient information for sending an email message to the DUT. Enter 60 characters of text: "Are you going to the party tonight? I will be there at eight" in the message body but do not yet send the email.

- Send 5 email messages to the DUT.
- Mobile data shall be turned off.
- The K-9 Mail application shall be opened.
- If the DUT does not support a back or return feature, then an alternative method can be used to move to the next message. The tester will record their alternate method in the test report.

Test Procedure:

- Begin measuring current drain (do not let display timeout before starting measurement).
- At the 10 second time mark, read the Email by clicking the first unread message in the inbox.
- You will have 9 seconds to read the message before having to press the "back" or "return" button to return to the inbox and 1 second after to press the next unread message to open it. This will be repeated for the duration of the test.
- Press the "Back" or "Return" at the 19, 29, 39, and 49 second time mark, and open the next unread message at the 20, 30, 40, and 50 second time mark.
- The test equipment will stop the current drain measurement 60 seconds after measurement was started. This represents one iteration of the data.
- Record the average current drain measurement for the test.
- Run this test for a total of 5 iterations and average the results.
- Calculate the average power consumed for this activity.

4.2.4 Home Screen Display On

The purpose of this test is to measure the power consumed while the display is on and the DUT is idle on the home screen.

Test Setup:

- Mobile data shall be turned off for this test case. The simulator shall allow the DUT to go to an RRC idle state after the initial attach.
- DUT shall be camped to the simulator with the display ON.
- The ATL test operator shall disable screen timeout and screen setting options in the DUT software menu. The DUT shall not dim nor blank the display during this test.
- Test case begins and ends with DUT on the home screen. The ATL test operator shall push the home screen icon (e.g., house, circle) one time in order to set the DUT to the home screen. After that, the ATL test operator shall not touch the DUT.

Test Procedure:

- Make sure that the DUT is on the home screen and that the display is ON.

- Begin measuring current drain.
- The test equipment will stop the current drain measurement 5 minutes after measurement was started.
- In the case where the screen timeout is shorter than the test time, the screen timeout should be set to the maximum to allow the test to complete. The test time may be reduced to the maximum timeout DUT allows (ensuring the test completes just before the screen expires).
- Record the average current drain measurement for the test. This represents one iteration of the data.
- Run this test for a total of 3 iterations and average the results.
- Calculate the average power consumed for this activity.

Post Test Procedure:

- The ATL test operator shall restore the DUT backlight and display timeout settings to the default settings after completion of the home screen display on test.

4.2.5 Audio Streaming/Music Playback

Use the *GSMA TS.09 [2]* test procedures.

4.2.5.1 Audio Streaming

- When performing the audio streaming test case, the audio shall be played using the manufacturer- provided headset, as opposed to that which is detailed in the GSMA test plan, which is defined in the DUT Details document.
- The volume shall be set to the default setting, in accordance with the DUT Details document.
- The preferred media player is to be the pre-installed web browser. If there is no pre-installed browser, then an alternative solution for measuring the current drain for audio streaming may be used.
- If the Audio Streaming can only be played with the Screen ON, then the screen timeout should be set to the maximum to allow the test to complete. In the case where the screen timeout is shorter than the test time and results in the termination of the audio, the test time may be reduced to the maximum timeout (ensuring the test completes just before the screen expires).
- The approved audio source file will be provided by the authorized test system vendors.
- Run test 3 times and average the results.

4.2.5.2 Music Playback

- The media may be played using the hard drive of the DUT and does not have to be played from an external SD card/media source.
- The volume shall be set to the default setting, in accordance with the DUT Details document.

- Navigate to the media file and click on it to open it. Select the option to open the media file using the preferred media player and start listening to the audio media clip.
- Mobile data shall be turned off for music playback.
- Run test 3 times and average the results.
- When performing the Music Playback test case, the audio shall be played using the manufacturer provided headset, which is defined in the DUT Details document.

4.2.6 Video Streaming

Use the *GSMA TS.09 [2]* test procedures.

- When performing the video streaming test case, the audio shall be played using the manufacturer- provided headset, which is defined in the DUT Details document.
- The volume shall be set to the default setting, in accordance with the DUT Details document.
- Display shall be ON and in landscape mode during the entire duration of this test
- The preferred media player is to be the pre-installed web browser. If there is no pre-installed browser, then an alternative solution for measuring the current drain for video streaming may be used
- The ATL test operator shall start playing the video on the DUT and then begin the measurement.
- This test shall be executed for a 10-minute duration in alignment with *GSMA TS.09 [2]* section 7.2.
- The approved 720p video source file will be provided by the authorized test system vendors. If the DUT does not support 720p, then the 480p file will be provided by the authorized test system vendor.
- Run this test 3 times and average the results.

4.2.7 Voice Call

Use the *GSMA TS.09 [2]* test procedures.

- The ATL test operator shall turn off the DUT display after starting the talk time voice call, before starting the current drain measurement.
- Current drain measurement shall begin once the DUT display is off.
- If the highest supported RAT is LTE and the DUT supports VoLTE, then the test shall be executed using the VoLTE Test from TS.09 section 4.4. Otherwise, the test is executed on WCDMA as per *GSMA TS.09 [2]* section 4.2.
- In the case of VoLTE testing, the default static Power Level shall be applied while in the case of WCDMA the Terminal Tx Power Distribution shall be used as specified in *GSMA TS.09 [2]*. The distribution shall be spread evenly for the total test time.

- For WCDMA the audio shall be routed through the normal audio path, not the speakerphone and no headset shall be connected to the DUT.
- For VoLTE, the audio is sourced from a PC playing a media file to simulate the user talking. This will be looped back at the simulator with a 5s delay to simulate the other party responding. This is detailed in *GSMA TS.09 [2]*.
 - The headset is used as specified in *GSMA TS.09 [2]*. To insert the audio from the PC, a method to tap into the uplink audio is necessary:
 - Connect the audio output from a PC (that is playing the TS.09 audio file) into the DUT's microphone (mic) connection (note, this will require signal levels to be matched).
 - Connect the audio output from the DUT to the headphones
 - **Figure 4.2-1** shows the Test Setup showing the break into the Uplink audio replacing the mic. A switch is shown in the case that only one headset is supplied for the Test Program.
- Run this test 3 times and average the results.

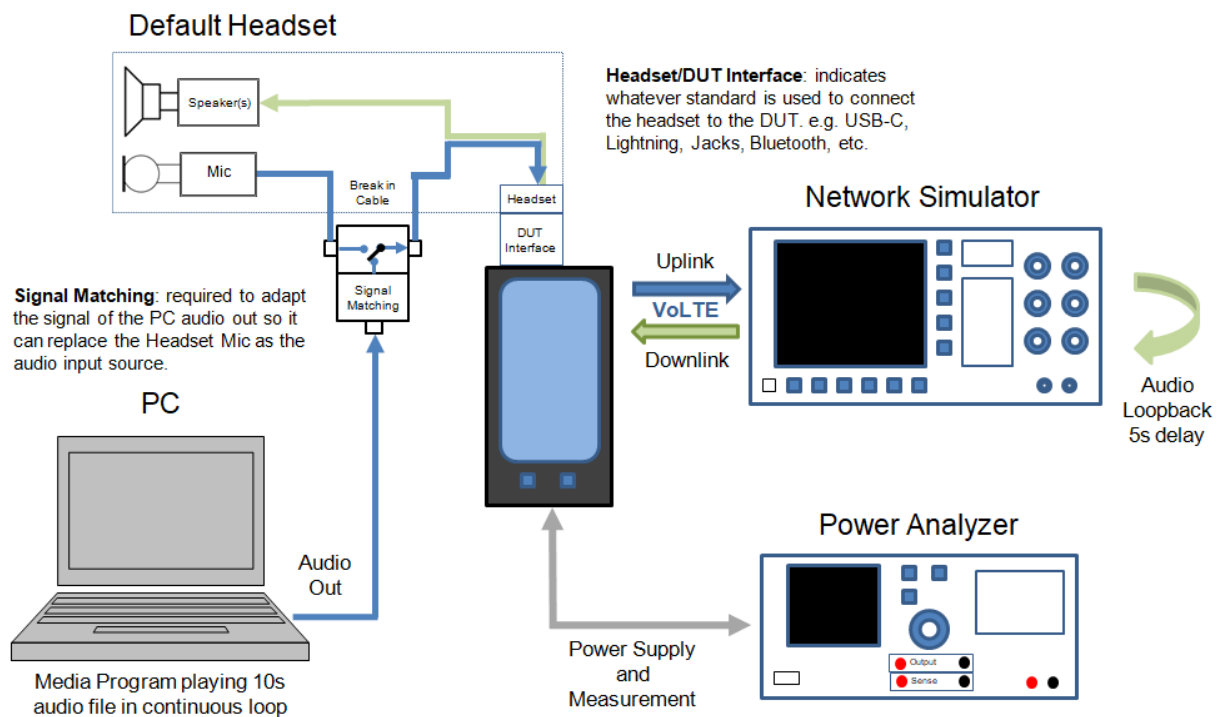

Figure 4.2-1 VoLTE Test Setup

4.2.8 Web Browsing

Use the *GSMA TS.09 [2]* test procedures.

- Begin measuring current drain before opening Kepler page 1.
- Press the “back” or “return” button a second before the 60 second mark and click on the next Kepler page at the 60 second mark.
- Repeat these steps for the duration of the Kepler pages.
- Do not press “back” or “return” button after the 5th Kepler page.
- After the test has been completed, the web browsers cache needs to be cleared from website and DUT to ensure the web pages are being downloaded every time.
- Run this test 3 times and average the results.
- Swiping/scrolling guidelines:
 - At the 20 second mark, using one continuous touching movement, scroll down to the bottom of the loaded page by swiping the finger up from the bottom to the top of the screen.
 - At the 40 second mark, using one continuous touching movement, scroll up to the top of the page by swiping the finger down from the top to the bottom of the screen.
 - One second before the full minute, press the “back” or “return” button to return to the overview page.
 - At the full minute mark, press the next Kepler page and allow it to load.

4.2.9 Standby

Use the *GSMA TS.09 [2]* test procedures.

- During the idle mode measurement per *GSMA TS.09 [2]*, mobile data shall be switched off.
- Run this test 3 times and average the results.

4.2.10 Location Services

The purpose of this test is to measure the power consumed while the DUT is running a Map based Location Service with a dynamic GPS scenario.

Test Setup:

- Mobile data shall be turned on for this test case. The simulator shall allow the DUT to go to an RRC idle state after the initial attach.
- The DUT shall be configured with the correct Date and Time to prevent potential issues loading maps.
- The Map Application shall be configured to ensure the location pointer remains on-screen throughout the test.

- Location Services shall be configured to ensure the DUT only uses GPS for identifying the Location (i.e., GPS Only Mode).
- The ATL test operator shall ensure that the screen remains on throughout the measurement.
- Prior to starting the measurement, the DUT must be setup to download the Map covering the simulated GPS location and acquire the location.
- Test case begins and ends with DUT running the Map Application with the screen display on and the DUT indicating it is moving along the route. The GPS scenario shall be running prior to the measurement to allow the DUT to acquire the GPS location.

Test Procedure:

- With the DUT in the RRC Idle State, Turn on Wi-Fi and log onto the AP.
- Launch the Map Application and wait for the DUT to acquire the simulated location and load the correct map for that location. Once this occurs, the Wi-Fi AP connection is to be forgotten/deleted prior to continuing. Note. If there are any issues in allowing the DUT to run the Map Application in an offline mode, then the Network Simulator should provide access to the internet through a LAN connection.
- Once the DUT displays the movement on the Map Application, begin measuring current drain. Note: the location simulation starts with a stationary location to improve acquisition time. The test must not start until after this stationary time.
- The test equipment will stop the current drain measurement 5 minutes after measurement was started.
- In the case where the screen timeout is shorter than the test time, the screen timeout should be set to the maximum to allow the test to complete. The test time may be reduced to the maximum timeout DUT allows (ensuring the test completes just before the screen expires).
- Record the average current drain measurement for the test. This represents one iteration of the data.
- Run this test for a total of 3 iterations and average the results.

Section 5 Energy Use per Activity – MIoT

5.1 Test Setup and Test Cases

The average voltage figure that was recorded in [Section 3](#) will be used as the fixed voltage setting in this section of the test plan. It is required that the dummy battery shall have sense line connections.

5.2 Network Parameters – NB-IoT

Except where specified in this section, the RF parameters shall be as defined in *GSMA TS.09 [2]* for LTE devices. The following settings will be applied.

Table 5.2-1 NB-IoT Network Settings

Parameter Setting	Recommended Value(s)	Comments
Operation Mode	Used spectrum is In-Band	For NB-IoT devices, the Operator may request Guard-band or Stand-alone.
T3412	186 minutes	Periodic Tracking Area Update (TAU). The Operator may request a different value.
PSM Timer T3324	As declared by OEM in DUT Details document.	Active Timer. If not specified in DUT Details document, a value of 600s shall be set.
eDRX Paging Window	As declared by OEM in DUT Details document	Disabled if not supported by DUT.
eDRX Cycle Length	As declared by OEM in DUT Details document	Disabled if not supported by DUT.
CE mode of operation parameters: Number of repetitions	NPRACH in CE0: 1 NPRACH in CE1: 8 NPRACH in CE2: 32	
TBS for DL and UL	Max DL TBS: 680 Max UL TBS: 1000	
NPUSCH power control	0-NominalNPUSCH-r13: -110 to – 114dBm Alpha-r13: 1 deltaPreambleMsg3-r13: 0dB	

Additionally, all settings according to Table 21 of *GSMA TS.09 [2]* shall be used unless indicated otherwise in this section.

All tests in this section will use SISO configuration and HARQ set to 2.

Dynamic Uplink Scheduling shall be used in conjunction with cDRX settings.

5.3 Network Parameters – Cat-M

The Simulator shall indicate support for Power Saving Mode. All applicable settings as per [Table 5.2-1](#).

5.4 Determination of Energy Use per Activity

In order to determine the energy use per activity, current drain measurements shall be performed. A dummy battery shall be used for all energy use per activity items. The current drain shall be used, along with the voltage, to determine overall power consumed by these activities.

The current drain (I) and the voltage (V) figures shall be recorded in the test report for each test case. The power consumed per activity shall be calculated using the formula $P = V * I$. The power consumed by each activity shall be recorded in the test report.

If possible, prior to testing, the ATL test operator shall confirm that there is no current drain due to the dummy battery being connected to the power supply while the DUT is not connected. Current drain measurements shall be performed on the following list of activities. The power consumed for each activity shall be determined based on the current drain measurements for each individual activity. Then, the power consumed shall be converted to a figure of energy. The energy used for the different activities shall be subtracted from the TAE figure from [Section 3.6](#).

5.4.1 Power Saving Mode

The purpose of this test is to measure the power consumed while the DUT in a Power Saving Mode. It should only be run if the DUT supports Power Saving Mode.

Test Setup:

- The DUT shall be configured through AT commands or other means provided to place the DUT in the Idle Mode State.
- The simulator shall allow the DUT to go to an RRC idle state after the initial attach.
- DUT shall then be placed in Power Saving Mode as specified by the OEM.
- T3412 should be set to a value to ensure the DUT remains in Power Saving Mode for the duration of the test.
- The ATL test operator shall disable any connection to the DUT that provides control. This is to ensure that the measurement is not affected by any driver specifically enabled for testing purposes.
- Test case begins and ends with DUT in a Power Saving Mode. The ATL test operator shall not touch the DUT during testing.

Test Procedure:

- Activate the DUT.
- After registration, wait 1 min for all boot processes to complete.
- Force the DUT into Power Saving Mode if not already occurred during above wait period.
- Begin measuring current drain.

- The test equipment will stop the current drain measurement 5 minutes after measurement was started. This represents one iteration of the data.
- Record the average current drain measurement I_{PSM} for the test.
- Run this test for a total of 3 iterations and average the results.
- Calculate the average power consumed for this activity.

5.4.2 Standby

The purpose of this test is to measure the power consumed while the DUT is in a Standby State. The Test procedure depends whether the DUT supports Power Saving Mode according to the DUT Details document.

5.4.2.1 Standby – PSM Supported

Test Setup:

- T3412 shall be set to a value greater than T3324 to ensure that the DUT will enter Power Saving Mode after the expiry of T3324 and eventually wake up on expiry of T3412.
- The DUT shall be configured through AT commands or other means provided to place the DUT in the Idle Mode State.
- The simulator shall allow the DUT to go to an RRC idle state after the initial attach and then Power Saving Mode.
- The ATL test operator shall disable any connection to the DUT that provides control. This is to ensure that the measurement is not affected by any driver specifically enabled for testing purposes.
- Test case begins when the DUT awakes from the Power Saving Mode state on expiry of T3412 and ends when the DUT returns back to Power Saving Mode.
- The ATL test operator shall not touch the DUT during testing.

Test Procedure:

- Begin measuring current drain just prior to the DUT leaving Power Saving Mode (expiry of T3412).
- The test equipment will stop the current drain measurement after the TAU procedure has completed and T3412 expires and the DUT returns to Power Saving Mode. This represents one iteration of the data.
- Record the average current drain measurement I_{IDLE} and T_{IDLE} for the test.
- Run this test for a total of 3 iterations and average the results.
- Calculate the average power consumed for this activity.

5.4.2.2 Standby – PSM Not Supported

In the case where Power Saving Mode is not supported, there are 2 discrete measurements required with a calculation made to extrapolate the total result.

Test Setup:

- T3412 shall be set to a value greater than $5 * (\text{Paging Time Window} + \text{eDRX Cycle Length})$.
- The DUT shall be configured through AT commands or other means provided to place the DUT in the Idle Mode State.
- The ATL test operator shall disable any connection to the DUT that provides control. This is to ensure that the measurement is not affected by any driver specifically enabled for testing purposes.
- The first measurement is to capture the current drain of the TAU procedure. The measurement will begin when T3412 expires to capture the RRC procedure and ends with the DUT returning to Idle Mode state.
- The second measurement shall start a short time after and stop after $4 * (\text{Paging Time Window} + \text{eDRX Cycle Length})$.
- The ATL test operator shall not touch the DUT during testing.

Test Procedure:

- For the first measurement, begin measuring current drain just prior to the expiry of T3412 to capture the RRC procedure.
- The test equipment will stop the current drain measurement after the TAU procedure has completed and the DUT returns to Idle Mode.
- This represents one iteration of the data.
- Record the average current drain (I_{TAU}) and the time taken (T_{TAU}) for the test.
- For the second measurement, begin measuring current drain after a short delay.
- The test equipment will stop the current drain measurement after $4 * (\text{Paging Time Window} + \text{eDRX Cycle Length})$.
- Record the average current drain (I_{IDLE}) and the time taken (T_{IDLE}) for the test.
- Calculate the average current I_{AVG} from both procedures using the following algorithm:

$$I_{\text{AVG}} = ((I_{\text{TAU}} * T_{\text{TAU}}) + (I_{\text{IDLE}} * T_{3412})) / (T_{\text{TAU}} + T_{3412})$$
- Run this test for a total of 3 iterations and average the results.
- Calculate the average power consumed for this activity.

5.4.3 Active Mode

The purpose of this test is to measure the power consumed while the DUT is in a Connected State transferring data.

Test Setup:

- The DUT shall be configured through AT commands or other means provided to place the DUT in the Idle Mode State,
- The simulator shall activate a connection after the initial attach. The simulator shall be configured for transaction length and average DL and UL throughput as declared in the DUT Details document.
- The ATL test operator shall disable any connection to the DUT that provides control. This is to ensure that the measurement is not affected by any driver specifically enabled for testing purposes.
- Test case begins and ends with DUT registered and in a connected state. The ATL test operator shall not touch the DUT during testing.

Test Procedure:

- Activate the DUT.
- After registration, wait 1 min for all boot processes to complete.
- The simulator shall enable a connection as specified in Section 5.2.
- Current drain measurement shall begin just prior to the initiation of the RRC Connection.
- The test equipment will terminate the connection depending on the Power Saving Mode:
 - If the DUT supports Power Saving Mode, the measurement shall terminate once the DUT enters Power Saving Mode. Note: it is expected this will be the length of the Connected Mode and a period T_{3324s} .
 - Otherwise, the measurement will terminate once the DUT enters RRC Idle state.
- This represents one iteration of the data.
- Record the average current drain measurement I_{CON} and the time taken T_{CON} for the test.
- Run this test for a total of 3 iterations and average the results.
- Calculate the average power consumed for this activity.

Section 6 User Profiles

6.1 Definition of User Profiles

Power consumption figures for individual activities from [Section 4](#) shall be used, in conjunction with the user profile weighting factors (# of times per day and duration of activities), to calculate the user profile result(s).

The list of activities for current drain measurement from [Section 4](#) shall each be assigned a weighting factor. The weighted activities which drain the smartphone or smartwatch battery shall be processed mathematically in order to arrive at a figure of expected hours of operation for the device.

The energy consumed will be subtracted from the overall TAE as determined in [Sections 3.4](#) and [3.6](#).

Section 7 Battery Life Rating

7.1 Calculation of Battery Life Rating

Once the user profiles are processed, a figure of estimated hours of operation shall be reported as the final result.

Appendix A DUT Configuration During Testing (for both TAE and Energy Use Per Activity)

Table A-1 DUT Configuration During Testing

Test Case	Title	Comments
ALL TEST CASES	Brightness Setting	For ABC-enabled devices the DUT brightness level shall be set to "X", corresponding to a 300 LUX condition. The adaptive brightness control shall be disabled. For DUT which do not support ABC, or ABC is off by default, the brightness level shall be set to the manufacturer default level as defined in the DUT Details document.
ALL TEST CASES	Mobile Data	Mobile data shall be turned on unless otherwise specified in the test case.
ALL TEST CASES	Volume Setting	Shall be the default as defined in the DUT Details document and recorded in the Test Report.
ALL TEST CASES	Backlight Off After X sec	Shall be set as defined in the DUT Details document and recorded in the Test Report as off after X sec.
ALL TEST CASES	Wi-Fi Status	Shall be enabled with no connection to any AP.
ALL TEST CASES	Bluetooth Status	Shall be the default as defined in the DUT Details document and recorded in the Test Report (on/off).
ALL TEST CASES	GPS Status	Shall be ON.
ALL TEST CASES	GPS Location Mode Status	Shall be ON. The default as defined in the DUT Details document shall be recorded in the Test Report (on/off). (Also may be battery saving, high accuracy, or device only mode settings)
ALL TEST CASES	NFC Status	Shall be the default as defined in the DUT Details document and recorded in the Test Report (on/off).
ALL TEST CASES	Email Push/Synch Settings	The K-9 Email App shall be the default application for all email related test cases. The default settings of the K-9 Email App shall be used, unless otherwise noted in this Test Plan.
ALL TEST CASES	Battery Saver Settings	For all DUT, the ATL is to set the battery saver setting to off by default.
ALL TEST CASES	Data Saver Settings	For all DUT, the ATL is to set the data saver setting to off by default.
ALL TEST CASES	Doze Mode Setting	For all DUT, the ATL is to set the doze mode setting to on by default.
ALL TEST CASES	Low power mode setting	For all DUT, the ATL is to set the low power mode setting to off by default.
ALL TEST CASES	Background application refresh setting	For all DUT, the ATL is to set the background application refresh setting to on by default.
Home Screen On	Backlight Off Disabled	Disable Backlight Off (e.g., screen timeout). All other backlight settings are default.

Test Case	Title	Comments
Voice Call	Backlight Setting	Confirm that the backlight is OFF before measurement for the voice call test case. All other backlight settings are default.
Audio Streaming	Backlight Setting	Confirm that the backlight is OFF for audio streaming test case (unless the test setup specifies otherwise). All other backlight settings are default.
Music Playback	Backlight Setting	Confirm that the backlight is OFF for music playback test case. All other backlight settings are default.
Video Streaming	Backlight Setting	Confirm that the backlight is ON for video streaming test case.
Compose SMS	Backlight Setting	Confirm that the backlight is ON for the compose SMS test case. No Internet connection shall be available for this test case.
Send SMS	Backlight Setting	Confirm that the backlight is ON for the send SMS test case and that the display does not timeout before starting the measurement. No Internet connection shall be available for this test case.
Read SMS	Backlight Setting	Confirm that the backlight is ON for the read SMS test case and that the display does not timeout before starting the measurement. No Internet connection shall be available for this test case.
Receive SMS	Backlight Setting	Confirm that the backlight is OFF as the initial condition for the Receive SMS test case. No Internet connection shall be available for this test case. All other backlight settings are default.
Compose Email	Backlight Setting	Confirm that the backlight is ON for the compose email test case. No Internet connection shall be available for this test case.
Send Email	Backlight Setting	Confirm that the backlight is ON for the send email test case and that the display does not timeout before starting the measurement. No Internet connection shall be available for this test case.
Read Email	Backlight Setting	Confirm that the backlight is ON for the read email test case and that the display does not timeout before starting the measurement. No Internet connection shall be available for this test case.
Receive Email	Backlight Setting	Confirm that the backlight is OFF as the initial condition for the Receive Email test case. No Internet connection shall be available for this test case. All other backlight settings are default.

Appendix B Network Simulation for NR Testing

B.1 5G NR Band Combinations

The following Tables indicate the Cell Configuration testing scenarios to be run for each Operator submission. Each entry in the FDD and TDD columns indicates a testing requirement for that specific operator

Table B.1-1 5G NR SA Band Combinations and NSA Bands per Operator

AT&T	LTE	FR1	
		FDD	TDD
SA		n5	
NSA	2	n2	n77

T-Mobile	LTE	FR1	
		FDD	TDD
SA		n71	n41
NSA			

DISH	LTE	FR1	
		FDD	TDD
SA		n70 and n71	n48 and n77
NSA			

B.2 General Cell Settings for LTE+NR NSA

Table B.2-1 General Cell Settings for LTE+NR NSA

Parameter	Required Setting		Comment
	LTE Cell	NR Cell	
Serving Cell Band	As specified by Operator	As specified by Operator	As per Table B.1-1
Serving Cell Bandwidth	10MHz	FDD: 20MHz TDD: 100MHz	
Serving Cell (E)ARFCN	Mid Range	Mid Range	
Serving Cell Subcarrier Spacing		FDD: 15kHzTDD: 30kHz	
Number of neighbours declared in the neighbour cell list	16 Intra-Frequency, 0 Inter-Frequency, 0 Inter-RAT No MBSFN Cells		The Test Equipment does not transmit these signals
DRX Cycle	1.28s		
Periodic TAU	No		T3412 set to OFF
Reference Signal Energy Per Resource Element (RS EPRE)	-85dBm/15kHz		
PBCH EPRE Ratio	PBCH_RA = 0dB PBCH_RB = 0dB		
PSS EPRE Ratio	PSS_RA = 0dB		
SSS EPRE Ratio	SSS_RA = 0dB		
PCFICH EPRE Ratio	PCFICH_RB = 0dB		
PDCCH EPRE Ratio	PDCCH_RA = 0dB PDCCH_RB = 0dB		
PDSCH EPRE Ratio	PDSCH_RA = 0dB PDSCH_RB = 0dB		
PHICH EPRE Ratio	PHICH_RA = 0dB PHICH_RB = 0dB		
Number of Antenna Ports	2		
Cyclic Prefix Length	Normal		
PHICH Duration	Normal		

Parameter	Required Setting		Comment
	LTE Cell	NR Cell	
PDCCH Length	2 Symbols		
DCI Aggregation Level	4 CCEs for DCI0 8 CCEs for all other		DCI0 to be configured for any unexpected Uplink activity
QRxLevMin	-120dBm		
QQualMin	-20dBm		
SintraSearchP	0dB		
SintraSearchQ	0dB		
Paging and System Information Change Notification on PDCCH	No		No P-RNTI on PDCCH
IMS VoPS	Supported		
OCNG	FDD: According to Table E-UTRA_FDD_IDLE_1 TDD: According to Table E-UTRA_TDD_IDLE_1		3GPP TS 36.521 [3], A.5.1.2
RoHC	OFF		
Uplink TX Power	10 dBm	10 dBm	
DL Transmission Scheme	2 x 2 Closed Loop spatial Multiplexing	2 x 2 Closed Loop spatial Multiplexing	Uses TX Mode 4
RRC Inactivity Timer	10s	10s	Operator may request different cDRX settings. The ATL shall record the settings used.
cDRX Configuration	ON	ON	
LongDRX Cycle	40 sub-frames	320 sub-frames	
onDuration Timer	4 sub-frames	2 sub-frames	
DRX-Inactivity Timer	4 sub-frames	100 sub-frames	
Short DRX	OFF	OFF	
NRB(DL)	12		
MCS(DL)	0		
NRB(UL)	20		
MCS(UL)	0		
TDD UL DL Configuration	1		

Parameter	Required Setting		Comment
	LTE Cell	NR Cell	
TDD Special sub-frame configuration	4		

B.3 NR Cell Settings for NSA Download Tests (Browsing, Streaming and E-mail)

Table B.3-1 NR Cell Settings for NSA Download Tests

Parameter	Required Setting	Comment
cDRX Configuration	ON	Operator may request different cDRX settings. The ATL shall record the settings used.
LongDRX Cycle	320 sub-frames	
onDuration Timer	2 sub-frames	
DRX-Inactivity Timer	100 sub-frames	
Short DRX	OFF	
Allocated resource blocks in DL	12	
MCS	20	
Allocated resource blocks in UL	1	

Note: All General Settings for LTE+NR NSA shall be used and superseded where found in this table.

B.4 NR Cell Settings for NSA Upload Tests (Send Email)

Table B.4-1 NR Cell Settings for NSA Upload Tests

Parameter	Required Setting	Comment
cDRX Configuration	ON	Operator may request different cDRX settings. The ATL shall record the settings used.
LongDRX Cycle	320 sub-frames	
onDuration Timer	2 sub-frames	
DRX-Inactivity Timer	100 sub-frames	
Short DRX	OFF	
Allocated resource blocks in DL	1	
MCS	20	
Allocated resource blocks in UL	1	

Note: All General Settings for LTE+NR NSA shall be used and superseded where found in this table.

B.5 NR General Cell Settings for SA Testing

Table B.5-1 NR General Cell Settings for SA Testing

Parameter	Required Setting	Comment
FDD Band	As specified by Operator	As per Table B.1-1
TDD Band	As specified by Operator	As per Table B.1-1
EARFCN	Mid Range	
Subcarrier Spacing	FDD: 15kHz TDD: 30kHz	
Bandwidth	FDD: 20MHz TDD: 100MHz	
Number of neighbours declared in the neighbour cell list	16 Intra-Frequency, 0 Inter-Frequency, 0 Inter-RAT No MBSFN Cells	The Test Equipment does not transmit these signals
DRX Cycle	1.28s	
Periodic TAU	No	T3412 set to OFF
Reference Signal Energy Per Resource Element (RS EPRE)	-85dBm/15kHz	
UL TX Power	0dBm	
Cyclic Prefix Length	Normal	
DL Transmission Scheme	2 x 2 Closed Loop spatial Multiplexing	
RRC Inactivity Timer	10s	Operator may request different cDRX settings. The ATL shall record the settings used.
cDRX Configuration	ON	
LongDRX Cycle	40 sub-frames	
onDuration Timer	4 sub-frames	
DRX-Inactivity Timer	4 sub-frames	
Short DRX	OFF	
NRB(DL)	12	

Parameter	Required Setting	Comment
MCS(DL)	0	
NRB(UL)	20	
MCS(UL)	0	

B.6 NR Cell Settings for SA Download Tests (Browsing, Streaming and Email)

Table B.6-1 NR Cell Settings for SA Download Tests

Parameter	Required Setting	Comment
cDRX Configuration	ON	Operator may request different cDRX settings. The ATL shall record the settings used.
LongDRX Cycle	320 sub-frames	
onDuration Timer	2 sub-frames	
DRX-Inactivity Timer	100 sub-frames	
Short DRX	OFF	
Allocated resource blocks in DL	12	
MCS Table	64 QAM	
Allocated resource blocks in UL	1	
TDD UL DL Configuration	7DL slots, 2 UL slots	
TDD Periodicity	10 slots	

Note: All General Settings for LTE+NR NSA shall be used and superseded where found in this table.

B.7 NR Cell Settings for SA Upload Tests (Send Email)

Table B.7-1 NR Cell Settings for SA Upload Tests

Parameter	Required Setting	Comment
cDRX Configuration	ON	Operator may request different cDRX settings. The ATL shall record the settings used.
LongDRX Cycle	320 sub-frames	
onDuration Timer	2 sub-frames	
DRX-Inactivity Timer	100 sub-frames	
Short DRX	OFF	
Allocated resource blocks in DL	1	

Parameter	Required Setting	Comment
MCS	20	
Allocated resource blocks in UL	1	

Note: All General Settings for LTE+NR SA shall be used and superseded where found in this table.

B.8 Test Requirement in LTE and NR

Table B.8-1 Test Requirement in LTE and NR

Section	Test Description	LTE	NR-SA	NR-SA	NR-NSA	NR-NSA
			FDD	TDD	FDD	TDD
3.1	Test Setup and Definition of Standard Discharge Profile (SDP)	X	X (Note1)	X (Note1)	(Note 2)	(Note 2)
4.2.1	Gaming	X	X (Note1)	X (Note1)	(Note 2)	(Note 2)
4.2.2.1	Compose SMS Message	X	X	X	(Note 2)	(Note 2)
4.2.2.2	Send SMS Message	X	X	X	(Note 2)	(Note 2)
4.2.2.3	Receive SMS Message	X	X	X	(Note 2)	(Note 2)
4.2.2.4	Read SMS Message	X	X	X	(Note 2)	(Note 2)
4.2.3.1	Compose Email Message	X	X	X	(Note 2)	(Note 2)
4.2.3.2	Send Email Message	X	X	X	X	X
4.2.3.3	Receive Email Message	X	X	X	X	X
4.2.2.4	Read E-mail Message	X	X	X	(Note 2)	(Note 2)
4.2.4	Home Screen Display On	X	X	X	(Note 2)	(Note 2)
4.2.5.1	Audio Streaming	X	X	X	X	X
4.2.5.2	Music Playback	X	X	X	(Note 2)	(Note 2)
4.2.6	Video Streaming	X	X	X	X	X
4.2.7	Voice Call	X	X	X	X	X
4.2.8	Web Browsing	X	X	X	X	X
4.2.9	Standby	X	X	X	X	X
4.2.10	Location Services	X	X	X	(Note 2)	(Note 2)

Note 1: Must be tested if Operator does not support LTE RAT. Only one of each test needs to be performed based on the Mode (FDD and/or TDD) testing request from the Operator.

Note 2: Use LTE test results or perform the measurements if LTE test results are not available.

Appendix C Revision History

Date	Revision	Description
April 2016	1.0	Initial release
February 2017	1.1	<ul style="list-style-type: none"> Section 1.2: WCDMA added. Removed references to GSM and cdma2000. Section 2: Added additional definitions. Section 2.3: Updated text to remove reference to CDMA test plan 3GPP2 c.R1013_0. Table 2.5-1: Updated DUT configuration for compose, send, receive, read email message test cases. Section 2.8: Created a new section for power supply and analyser settings. Section 4.2.2.1, 4.2.2.2, 4.2.2.3: Added additional instruction to Test Setup. Section 4.2.3.3: Added additional instruction to Test Setup and Test Procedure. Section 4.2.5, 4.2.7: Added additional instruction. Section 4.2.6: Modified the location of the video source files. Section 4.2.8: Modified swiping/scrolling guidelines.
July 2017	1.1.1	<ul style="list-style-type: none"> Section 2.1: Revised RGB numbers for white color and black color. Section 4.2.2.1, 4.2.2.2, 4.2.2.3, 4.2.2.4, 4.2.3.1, 4.2.3.2, 4.2.3.3, 4.2.3.4, 4.2.4: Removed "No Internet connection shall be available for this test case". Section 4.2.6: Changed GSMA TS.09 section to 7.1. Appendix A: Added "No Internet connection shall be available for this test case" to some test cases.
April 2018	1.2	<ul style="list-style-type: none"> Section 1.3 and 1.4: Removed 'Certification'. Section 1.5: Added additional acronyms and definitions. Section 2.1: Clarified light measurements and specified handling in case of non-resolution. Section 2.5: Updated the APN that should be used during testing. Section 3.6: Specified units as mWh. Sections 4.2.1, 4.2.2, 4.2.3, and 4.2.4: clarified recording average current only. Section 4.2.3: Editorial correction. Section 4.2.5, 4.2.6 and 4.2.7: Editorial corrections and updated the number of iterations for different test cases. Section 4.2.5 split into 2 subsections. Section 4.2.5.1: Clarified headset use in relation to GSMA TS.09. Defined the orientation of the screen for each test case. Defined the test cases where a headset is required for testing. Defined the settings for notifications for all tests. Updated diagrams for TAE and energy use per activity.
July 2019	1.3	<ul style="list-style-type: none"> Section 1.1 – Added smartwatch. Section 1.2 – Indicated VoLTE preferred option. Section 1.3 – GSMA TS.09 version 10.1 referenced. Section 1.5 <ul style="list-style-type: none"> – Added acronyms DRX and cDRX. – New definitions added. Section 2.1 – Added smartwatch. Section 2.3 <ul style="list-style-type: none"> – Indicated Dynamic Uplink Scheduling preferred option. – Referenced GSMA TS.09 Table 21. Section 2.9 – Created wearables section. Table 4.2-1 – Modified for applicability. Section 4.2.7 <ul style="list-style-type: none"> – Indicated voice call uses VoLTE test from GSMA TS.09 version 10.1. – Added clarification of the modification to the headset required for the TS.09 specified VoLTE test. Section 5.1 – Added of smartwatch result handling.
October 2018	1.3.1	<ul style="list-style-type: none"> Added clarification of GPS and Location Services Settings in Appendix A. Added clarification of Wi-Fi terminology in Section 1.5 and 2.5. Added clarification of 4.2.3.3 Receive email. Added details to progress the Angry Birds when the Application will not run.

Date	Revision	Description
August 2019	1.4	<ul style="list-style-type: none"> • Automatic Brightness Control renamed to Adaptive Brightness Control. • Reworked Section 2 for Screen Brightness Control with Aspect Ratio correction to Preferred Picture. • Added clarification of Power Profile Template usage in Section 2.5 and 4.2.7. • Added clarification on SG-SMS being used for SMS testing. • Defined how to handle devices that do not have menu back feature. • Added clarification on handling 'back' or 'return' to InBox for SMS tests. • Explicit use of K-9 Mail App specified for email. • Header defined for Sending and Receiving emails. • Handling of Auto Signature specified. • Added clarification that Push is the default requirement for Sending email. • Added clarification on handling 'back' or 'return' to InBox for email tests. • Specified use of headset for Music Playback. • Section 4.2.8 Web Browsing procedure reworked. • Backlight Setting clarified in Appendix A.
October 2020	1.5	<ul style="list-style-type: none"> • Clarified RF conditions for in case where DUT does not support MIMO. • Clarified situation where no audio plug is available. • Corrected statement that a smartwatch should not be connected at all times to a smartphone. • Created SIM section to clarify requirements to support eSIM. • Clarified the media player to be used for Music Playback. • RTSP and VLC Streaming replaced by Dynamic Adaptive Streaming over HTTP (DASH). • Added details on reducing test time for streaming tests and removed power profile. • Clarified header volume for Music Playback. • Section 2.5: Adapted the simulator to mimic functionality in the network regarding handling the number of ports that are available to the DUT at runtime in the MIMO configuration. • Section 2.9: Clarified that different hardware may be used for different aspects of testing. • Clarified screen setting for Audio Streaming test and Appendix A. • Changed CATL to ATL.
November 2020	1.5.1	<ul style="list-style-type: none"> • Updated CTIA Certification URL.
May 2021	1.6	<ul style="list-style-type: none"> • Added new Section 5 containing MIoT testing. • Updated Section 1.5 with new acronyms and their definitions. • Renamed call box to simulator in Section 4.2.4. • Added Section 2.1.3 for GNSS Simulator. • Updated Appendix A with GPS location based services setting.
July 2021	1.6.1	<ul style="list-style-type: none"> • Added clarification to Section 4.2.4, Test Procedure.
October 2022	1.7	<ul style="list-style-type: none"> • Corrected section references in Table 4.2.1 • Added Section 4.2.10, Location Services Test. • Added Catapult Quest to Section 4.2.1
April 2024	2.0	<ul style="list-style-type: none"> • Added Appendix B.8. Test requirement in LTE and NR • Modified RAT-related test conditions • Modified the bands T-Mobile • Added conditions for test cases selection
August 2024	2.0.1	<ul style="list-style-type: none"> • Specified Camped on LTE or 5GNR • Indicate LTE or 5GNR Power Profile