



Test Plan for RF Performance Evaluation of Wi-Fi Mobile Converged Devices

Version 2.1.2

December 2020

© 2006 - 2020 CTIA Certification and Wi-Fi Alliance. All Rights Reserved.

Any reproduction, modification, alteration, creation of a derivative work, or transmission of all or any part of this publication ("Test Plan"), in any form, by any means, whether electronic or mechanical, including photocopying, recording, or via any information storage and retrieval system, without the prior written permission of CTIA Certification and Wi-Fi Alliance, is unauthorized and strictly prohibited by federal copyright law. This Test Plan is solely for use within the CTIA Certification and Wi-Fi Alliance certification programs. Any other use of this Test Plan is strictly prohibited unless authorized by CTIA Certification and Wi-Fi Alliance, or its assigns, in writing. This Test Plan is provided on an "as is basis."

Use Instructions

All testing to this test plan must be conducted in a CTIA Certification and Wi-Fi Alliance Authorized Test Lab. This may be accomplished in one of two ways:

1. As part of a PTCRB certification request submitted at <https://www.ptcrb.com/>
2. By submitting an OTA Test Plan use request at <https://certify.ctiacertification.org/>

CTIA Certification LLC

1400 16th Street, NW
Suite 600
Washington, DC 20036 USA
+1.202.785.0081
programs@ctiacertification.org
ctiacertification.org/test-plans/

Wi-Fi Alliance

10900-B Stonelake Boulevard
Suite 126
Austin, TX 78759 USA
+1.512.498.9434
support@wi-fi.org
www.wi-fi.org

Acknowledgements

This test plan was created by the wireless industry with input from the following companies and their representatives:

Company, Representative	Company, Representative
AT&T , Scott Prather, Sungmi Choi, Jason Brown	NEC , Sanjay Wadhwa
Azimuth Systems , Charles Wright	Nokia Corp. , Alan Ewing, Steve Wilhoff, Randy Leenerts, Karthik Babu Adappa Laxmi, Kevin Li
Blackberry , Michael Montemurro	Philips Semiconductor , Steve Shearer
CETECOM, Inc , Lothar Schmidt	PCTEST Engineering Lab , Ronald Borsato, Matt Smith
Cisco , Sam Kim, Jae il Choi	Rohde & Schwarz , Lisa Ward, Christoph Gagern, Thorsten Hertel, Alex Tkatch
Dell , Johnny Gutierrez, Justin Harbour, Elvis Yen	Samsung , Chirag Panchal, James White, Kwangmin Choi, Usman Aurakzai
DSP Group , Graham Smith	Satimo , John Estrada, Kim Rutkowski, Alessandro Scannavini
ETS-Lindgren , Michael Foegelle, Edwin Mendivil	SGS , Jason Bartosch, Nicky (Ho) You, Peter Liao
Fitbit , Kevin Li	Spirent Communications , Ronald Borsato
Intel , Hassan Yaghoobi	Sporton , Elvis Yen, Lorien Chang, Alexander Ho
Ixia , Larry Green	Sprint , Alex Tkatch
Keysight , Moray Rumney	Telecommunications Metrology Center of China Ministry of Information Industry , Heather Gao
Microsoft , Kevin Li	Underwriters Laboratories , Ekta Budhbhatti
Motorola Mobility , Paul Moller, Istvan Szini	Wi-Fi Alliance , Patrick Green, Steve Shearer
Multi-Tech , Jody Lanes	

Table of Contents

Section 1	Introduction	6
1.1	Background	6
1.2	Scope	6
1.3	Purpose	6
1.4	References	7
1.5	Test Nomenclature Overview	7
1.5.1	Conducted RF Tests	7
1.5.2	Radiated RF Tests	7
1.5.3	Desensitization Tests	7
1.6	Baseline Methodology	7
1.6.1	Measurement Techniques and Test Methodologies	7
1.6.2	Measurement Uncertainty	8
1.6.3	Minimum Measurement Distance	8
1.6.4	Quiet Zone Test Frequencies	8
1.7	Form Factor Submission for Self-contained Wi-Fi/Mobile Modules	8
1.8	List of Acronyms	9
Section 2	Test Conditions and Device Configuration	10
2.1	Cellular and Wi-Fi Modes	10
2.2	Wi-Fi Mode	10
Section 3	Conducted Measurements	12
3.1	Wi-Fi Conducted RF Power Output and Receiver Sensitivity Tests	12
3.1.1	Test Purpose	12
3.1.2	Test Setup	12
3.1.3	Measurement Frequencies and Data Rates for Conducted tests	12
3.1.4	Test Procedure for Output Power Level	13
3.1.5	Test Procedure for Receiver Sensitivity	14
3.1.6	Results	15
Section 4	Radiated Measurements	16
4.1	Wi-Fi Total Radiated Measurements (TRP/TIS)	16
4.1.1	Test Purpose	16
4.1.2	Test Setup	16
4.1.3	Measurement Frequencies for Radiated Tests	17
4.1.4	Test Procedure for Total Radiated Power Measurement	18
4.1.5	Test Procedure for Total Isotropic Sensitivity Measurement	18
4.1.6	TRP Data Rates	19
4.1.7	TIS Data Rates	19
4.1.8	Results	20
4.2	Wi-Fi Desense Measurements with Cellular Transmitter ON	20
4.2.1	Test Purpose	20
4.2.2	Test Setup	20

4.2.3	Test Procedures for Wi-Fi Radio Desensitization	21
4.2.4	Wi-Fi Radio Desensitization by Closest Cellular Uplink Frequency	22
4.2.5	Wi-Fi Radio Desensitization by Cellular Radio Uplink Harmonics	25
4.2.6	Results	28
4.3	Cellular Desense Measurements with Wi-Fi transmitter ON.....	29
4.3.1	Test Purpose	29
4.3.2	Test Setup	29
4.3.3	Test Procedure for GSM, CDMA and UMTS RATs listed in the CTIA Test Plan 30	
4.3.4	Test Procedure for RATs	30
4.3.5	Test Procedure for all LTE cases.....	31
4.3.6	Wi-Fi Frequency	31
4.3.7	Error Rate Measure.....	31
4.3.8	Results	32
Appendix A Summary Test Report.....		33
A.1.	Wi-Fi Conducted Tests	34
A.2.	Total Radiated Power (TRP)and Total Isotropic Sensitivity (TIS) for 2.4 GHz 802.11b, 802.11g and 802.11n	37
A.3.	Total Radiated Power (TRP) and Total Isotropic Sensitivity (TIS) for 802.11a and 802.11n.....	38
A.4.	Wi-Fi Desense Measurements (with cellular transmitter on)	40
A.5.	Cellular Desense Measurements (with Wi-Fi transmitter on).....	41
Appendix B Handheld Device Testing Configurations		43
Appendix C Radio Access Technologies that Require Testing, but are not Normative in the CTIA Test Plan		44
C.1	TD-SCDMA.....	44
C.2	LTE TDD.....	44
Appendix D Notebook and Tablet Requirements		46
D.1	Parent/Child Relationships	46
D.2	Parent/Child Antenna Subsystem Considerations	46
D.3	Test Configurations and Setup Procedures	46
Appendix E Wi-Fi-LTE Emulator Test Equipment Notes when Testing EUTs that Support LTE Band 40 or 41 (Informative)		48
Appendix F Table of Wi-Fi Radio channels interfered by Cellular Radio Harmonics		50
Appendix G Change History		59

Section 1 Introduction

1.1 Background

Increasingly, the wireless market is seeing converged devices that incorporate both cellular and wireless local area network (WLAN or Wi-Fi) functionality. Due to the many potential applications and deployment scenarios that converged devices may ultimately function in, operators and device vendors are interested in a uniform and standard way for profiling the RF performance of the devices and associated test methodology. With this standard approach, equipment designers, system operators, and RF engineers have the flexibility to determine their own appropriate RF performance criteria based on their engineering assessments and can easily identify equipment that is suitable for each deployment and application.

1.2 Scope

This test document specifies test methodologies and performance criteria for the RF performance evaluation of Wi-Fi mobile converged devices. The scope of testing includes Handheld, self-contained Wi-Fi/Mobile Module, Access Point, Notebook and Tablet devices that support IEEE 802.11a, 802.11b, 802.11g, 802.11n, and/or 802.11ac [2] as well as cellular technologies. Support for IEEE 802.11 standards shall be confirmed through Wi-Fi Alliance baseline certification—that is, devices tested using this test plan shall first be Wi-Fi CERTIFIED for IEEE 802.11a, 802.11b, 802.11g, 802.11n and/or 802.11ac [4]. Cellular technologies include GSM, CDMA, UMTS (WCDMA), LTE and TD-SCDMA.

This document relies on the measurement techniques and methodologies within the CTIA Certification Test Plan for Wireless Device Over-the-Air Performance [1] (referred to in this document hereafter as “CTIA OTA Test Plan”).

1.3 Purpose

The purpose of this document is to define the test methodology for the RF testing of Wi-Fi mobile converged devices and to specify the test conditions for each test case. The testing covers client devices and access points and specifies conducted as well as radiated tests.

1.4 References

- [1] “Test Plan for Wireless Device Over-the-Air Performance/Method of Measurement for Radiated RF Power and Receiver Performance”, latest revision, CTIA Certification <https://ctiacertification.org/test-plans>.
- [2] “IEEE Std. 802.11-2016 IEEE Standard for Information technology--Telecommunications and information exchange between systems Local and metropolitan area networks--Specific requirements Part 11: Wireless LAN Medium Access Control (MAC) and Physical Layer (PHY) Specifications”
IEEE <http://standards.ieee.org/getieee802/download/802.11-2016.pdf>
- [3] “User Equipment (UE) / Mobile Station (MS) Over The Air (OTA) antenna performance; Conformance testing (3GPP TS 34.114)”, Latest Revision,
3GPP <http://www.3gpp.org/DynaReport/34114.htm>
- [4] Check the product’s Wi-Fi Certificate at:
http://certifications.www.wi-fi.org/wbcs_certified_products.php?lang=en
- [5] RFC 792 “Internet Control Message Protocol”, IETF, September 1981
<https://tools.ietf.org/html/rfc792>
- [6] RFC 1122 “Requirements for Internet Hosts – Communication Layers”, IETF, October 1989.
<https://tools.ietf.org/html/rfc1122>

1.5 Test Nomenclature Overview

1.5.1 Conducted RF Tests

Conducted tests are those RF Tests where the test equipment is connected to the antenna connector of the device under test by co-axial cables. These tests are formulated to measure basic RF performance such as sensitivity and transmit power.

1.5.2 Radiated RF Tests

Radiated tests are those RF Tests that are carried out in a test environment which meets the requirements of the CTIA OTA Test Plan [1]. These include Wi-Fi radiated Tx Power (TRP), Wi-Fi radiated Receive Sensitivity (TIS), Radiated Receive Sensitivity of Wi-Fi with cellular active, and Radiated Receive Sensitivity of the cellular radio(s) with Wi-Fi active.

1.5.3 Desensitization Tests

Desensitization tests measure the impact that the cellular radio, when transmitting, has upon Wi-Fi reception and visa-versa. These tests are performed as radiated tests according to Device Testing Configurations.

1.6 Baseline Methodology

1.6.1 Measurement Techniques and Test Methodologies

TRP and TIS in cellular mode are defined in both the CTIA OTA Test Plan [1] and User Equipment (UE) / Mobile Station (MS) Over The Air (OTA) antenna performance; Conformance testing (3GPP TS 34.114) [3].

This document relies on the measurement techniques and methodologies within the CTIA OTA Test Plan [1] developed specifically for the purposes of measurement of radiated transmit power and

sensitivity. The techniques specified in the CTIA OTA Test Plan [1] shall be used as the baseline test methodologies for all tests in here, unless otherwise stated. This document contains information to expand the CTIA OTA Test Plan [1] for use with 802.11 a, b, g, n and ac devices. Since the physical layer characteristics of 802.11n and 802.11ac are the same for the specified test conditions, for the purposes of this test plan, an 802.11ac device shall be tested as an 802.11n device. In the test procedures described below, 802.11ac devices shall be tested following the same test procedures and conditions as an 802.11n device. These sections are meant to clarify for the user how the CTIA OTA Test Plan [1] can be utilized for Wi-Fi enabled converged devices.

1.6.2 Measurement Uncertainty

Refer to CTIA OTA Test Plan [1] Section 7 for the uncertainty budget tables for TRP and TIS. The lab shall report their estimated measurement uncertainty for both the 2.4 and 5 GHz bands. However, the criteria in CTIA OTA Test Plan [1] Section 7.5 only apply to the 2.4 GHz band.

1.6.3 Minimum Measurement Distance

This section describes the minimum measurement distance, R, which the Far-Field test site shall provide. The measurement distance is defined as the distance from the center of rotation of the EUT to the phase center (alternatively, if not accurately known, the nearest point) of the Measurement Antenna.

For Cellular minimum measurement distance, refer to CTIA OTA Test Plan Section 3.1. [1] For Wi-Fi 2.4 GHz band, the minimum measurement distance specification specified for Band 41 shall be used. For Wi-Fi 5 GHz band, the minimum measurement distance is FFS; refer to Sections G.7.4 and G.19.1 of the CTIA OTA Test Plan [1] for more information.

1.6.4 Quiet Zone Test Frequencies

Quiet zone test frequencies shall be measured for the following Wi-Fi bands.

1. ISM-band: 2450 MHz \pm 1MHz (sleeve dipole and loop probe antenna)
2. U-NII-band: 5500 MHz \pm 1MHz (sleeve dipole and loop probe antenna)

1.7 Form Factor Submission for Self-contained Wi-Fi/Mobile Modules

The following two cases are considered regarding the antenna subsystem options and required form factor submission for self-contained Wi-Fi/Mobile modules. Also, please refer to Appendix D for Notebook and Tablet.

The test results shall include a description and diagram or photograph of the test conditions used for the device under test.

CASE 1 with Internal Antenna: If the EUT is a self-contained Wi-Fi/Mobile Module with internal antennas, such as a PC Card, then the vendor may choose one of the following options:

1. Supply the EUT together with one of its intended host platforms, e.g., a laptop computer. In this case, the combination shall then be placed on the turntable and the results sheet shall clearly state the combination that was used in the measurements.
2. Test the Module, on its own, mounted in a holder that orientates the module in the position that represents its normal use. In this case the results sheet shall clearly state that the test did not include a host device.
3. Carry out both tests as above. This is the preferred method, but not mandatory.

CASE 2 without Internal Antenna: If the EUT is a self-contained Wi-Fi/Mobile Module without internal antennas, such as an mPCI Card, then the vendor shall supply the complete device, which includes the antennas, for testing. No individual module testing is acceptable.

1.8 List of Acronyms

Acronym	Definition
ACK	Acknowledge
APSD	Automatic Power Save Delivery
CDMA	Code Division Multiple Access
EIS	Effective Isotropic Sensitivity
EUT	Equipment Under Test
GSM	Global System for Mobile communication
LAN	Local Area Network
LTE	Long Term Evolution
MIMO	Multiple Input Multiple Output
PER	Packet Error Rate
RAT	Radio Access Technology
Rx	Receive
TD-SCDMA	Time Division Synchronous Code Division Multiple Access
TIS	Total Isotropic Sensitivity
TRP	Total Radiated Power
Tx	Transmit
UMTS	Universal Mobile Telecommunications System
UTRA-FDD	UMTS Terrestrial Radio Access - Frequency Division Duplexing
UTRA-TDD	UMTS Terrestrial Radio Access - Time Division Duplexing
WCDMA	Wideband Code Division Multiple Access
WLAN	Wireless Local Area Network
WWAN	Wireless Wide Area Network

Section 2 Test Conditions and Device Configuration

2.1 Cellular and Wi-Fi Modes

The test methodology requires the device be placed in a standard operational mode. This includes all sensors in the device as well as proximity sensors. If it becomes evident that EUT thermal protection and/or adaptive power control mechanisms are preventing Wi-Fi and cellular transmitters from maintaining full output power during the course of testing, the test lab shall work with the OEM to identify a suitable mitigation method. Although recognizing that the use of special test modes would enable more simplified testing and the use of formal test equipment, the test methodology proposed in this document allows the testing of any Wi-Fi mobile device in a mode that is as close as possible to its native operation. However, the methodology does require certain specific behavior of the device so that the test can be executed. EUT vendors are required to supply instructions for the lab to configure the devices as specified in this test plan.

All Radiated tests shall be made according to configurations specified in Device Testing Configurations with the device oriented as specified in [Appendix A.A.1](#) or [Appendix A.A.5](#) (as appropriate) of the CTIA OTA Test Plan [1] as applied to the Wi-Fi mode being tested.

Depending on the communication tester and device capabilities, it may be necessary to set or disable the regulatory domain (WLAN Country Code and/or Cellular MCC) setting on the WLAN tester and/or cellular base station simulator in order to test specific channel combinations. Care should be taken to present the specific regulatory domain information to the EUT in an isolated environment so that the regulatory domain information is not obtained from any external Wi-Fi access point and/or cellular network in the country where the test is being executed. The lab should seek guidance from the EUT vendor to ensure that all test channels supported by the EUT are tested.

2.2 Wi-Fi Mode

The EUT is expected to be able to associate with the WLAN tester and stay on the same RF channel for the duration of the test even when the WLAN tester signal appears to be below the sensitivity level of EUT.

In this test plan, the PING based method is the primary method for packet generation for UL Power measurement while the ACK based method is the fall back option if the EUT does not support the PING method. The PING method is the only method to test the conducted (or radiated) power for the 802.11n mode of an 802.11 device.

In the PING based method, the WLAN tester generates ICMP echo request packets with configurable transmit interval, payload size and payload type. The ICMP echo request packets are targeted at the EUT's IP stack. The EUT is expected to answer with a well-defined echo reply packet whose payload is identical to the payload of the corresponding request. For this method to be usable, the device must conform to RFC 792 [5] and RFC 1122 [6] Section 3.2.2.6.

In the ACK based method, the WLAN tester will be transmitting data frames addressed to the EUT, and the EUT is expected to be able to respond to all of these data frames with an ACK message.

Because 802.11n ACKs are sent in the basic service set (which is in the legacy mode), the 802.11n ACK is sent at 6 Mbps. However, the lowest data rate for 802.11n is 6.5 Mbps. Therefore, the PING method is the only method to test the conducted (or radiated) power for the 802.11n mode of an 802.11 device. In this method, IP traffic message will force the EUT to answer and generate defined uplink traffic using an 802.11n data rate.

The following EUT settings are required to perform the test:

- Disable scan mode during testing; scanning for AP/client on other channels shall be disabled
- If applicable, disable Power Save Mode (Note that the WLAN tester will not support WMM APSD)
- If applicable, disable the Bluetooth radio during tests
- Except for the desense testing, the cellular transmitter in the EUT shall be inactive

Radiated testing shall be performed on an unmodified device using all active antennas. Conducted tests shall be performed on each antenna port with the other antenna port(s) properly terminated. If necessary, an equivalent device may be modified to provide conducted access to each antenna port.

For all Wi-Fi RATs, including 802.11n, 20 MHz channels are used. 802.11n should be configured for a long guard interval.

Section 3 Conducted Measurements

3.1 Wi-Fi Conducted RF Power Output and Receiver Sensitivity Tests

3.1.1 Test Purpose

The purpose of this test is to measure the output power level and receiver sensitivity of the Wi-Fi transceiver in the device in the conducted mode.

3.1.2 Test Setup

The basic test setup is shown in [Figure 3.1-1](#).

FIGURE 3.1-1 BLOCK DIAGRAM FOR WI-FI CONDUCTED MEASUREMENT



[Figure 3.1-1](#) is intentionally generalized to maximize test equipment design flexibility. A WLAN tester may include receiver and access point capability sub modules as well as internally implemented attenuators to control transmit and receive power to and from EUT.

The EUT shall be provided to the Test Laboratory with the facility to connect directly to the RF test equipment. This may be via an existing antenna connector, or it may be a carefully modified unit to allow such connection. In the latter case, it is the responsibility of the supplier of the EUT to ensure that the connection is present and suitable.

It is recommended that the conducted measurements be performed inside a shielded environment.

A reference measurement shall be made in order to account for the attenuation of the cable used for connecting the EUT and WLAN tester.

For more information about possible test setup configurations and details, refer to Appendix A of the CTIA OTA Test Plan [1] for setup illustrations.

3.1.3 Measurement Frequencies and Data Rates for Conducted tests

The measurements shall be performed on the lowest, middle¹ and highest channels supported by the device, in each of the 2.4 GHz and 5 GHz bands, at all data rates specified in [Table 3.1-1](#) and [Table 3.1-2](#).

¹ For 5 GHz bands, refer to [Table 4.1-1](#) for the middle channel number for each sub band.

TABLE 3.1-1 TX TEST DATA RATES FOR CONDUCTED TESTING

Band	Mode	Tx Data Rate (Mbps)
2.4GHz	IEEE 802.11b	11
	IEEE 802.11g	6
	IEEE 802.11n	6.5
5GHz	IEEE 802.11a	6
	IEEE 802.11n	6.5

TABLE 3.1-2 RX TEST DATA RATES FOR CONDUCTED TESTING

Band	Mode	Rx Data Rate (Mbps)
2.4GHz	IEEE 802.11b	11
	IEEE 802.11g	6, 54
	IEEE 802.11n	6.5, 65
5GHz	IEEE 802.11a	6, 54
	IEEE 802.11n	6.5, 65

3.1.4 Test Procedure for Output Power Level

This test procedure defines the basic method for measuring the transmit power of the EUT. A WLAN tester is used to establish the connection and generate traffic to and from the EUT. A calibrated WLAN tester or other applicable power measurement device (e.g., signal analyzer) is used to provide traceable power measurements.

With the PING based packet generation method, the WLAN tester will generate ICMP echo request packets with configurable transmit interval, payload size and payload type. The ICMP echo request packets are targeted at the EUT's IP stack. The EUT is expected to answer with a well-defined echo reply packet whose payload is identical to the payload of the corresponding request.

If the ACK based packet generation method is used, the power is measured across multiple ACK control frames from the EUT rather than full data packets. The ACK control frames are sent in response to unicast data packets generated by the WLAN tester. The measurement is taken across multiple packets and a mean value calculated.

For client devices, the tester is typically configured as an AP, although the tester may alternatively be configured as a non-AP STA (networking station) operating in ad-hoc mode to perform the measurement. The tester shall be configured to the channel (frequency) and data rate to be tested as specified in Section 3.1.3. Additional tester settings may also be needed to ensure that the EUT responds at the target data rate.

For access points and devices acting as mobile access points, the tester is configured as a client. In this case, the EUT shall typically be configured for the channel to be tested as specified in Section 3.1.3. The tester shall be configured for the data rate to be tested as specified in Table 3.1-1. Additional tester settings may also be needed to ensure that the EUT responds at the target data rate.

The EUT shall be configured to transmit at maximum power.

To generate the traffic for power measurement using the PING based method, the WLAN tester will generate ICMP echo request packets with configurable transmit interval and payload size and payload type as specified in Table 3.1-3. The reported result is determined from the power measured

over the entire payload part of the packet, ignoring the preamble and avoiding the leading and falling edge transitions in the burst. A minimum of 85% of the payload shall be covered by the measurement.

To generate the traffic for power measurement using the ACK based method, the tester is configured to send UDP packets as specified in [Table 3.1-3](#). [Table 3.1-3](#) specifies the size and payload of the packets to be transmitted and the target interval between packets. The transmitted power of the EUT is measured using the WLAN tester or other calibrated receiver capable of measuring the average power of the DATA portion of each ACK message. The reported result is determined from the power measured per ACK averaged over the number of ACKs specified in [Table 3.1-3](#).

Create a table of channel, data rate, and average power for each measurement. See [Appendix A](#) for recommended data reporting formats.

TABLE 3.1-3 PARAMETER SETTINGS FOR OUTPUT POWER LEVEL TEST

Parameter	Value
Number of measurements to be averaged	PING Based: 10 ACK Based: 100
Interval between packets (ms)*	10
Tester payload size (bytes)	PING Based: 1000** ACK Based: 60
Tester packet payload	Pseudo random
<p>*Note: The Interval between packets is defined as the interval between the end of a transmitted unicast packet and the beginning of the next transmitted unicast packet. If the device is capable of responding reliably to packets at the 10 ms interval, this time interval may be decreased. If the device is not capable of responding reliably to packets at the 10 ms interval, this time interval may be increased as required. Indicate the used interval size in the test report.</p> <p>**Note: If a device does not support the required packet size, use the maximum supported and indicate the used packet size in the test report.</p>	

3.1.5 Test Procedure for Receiver Sensitivity

This test procedure measures the Wi-Fi receiver sensitivity of the EUT using the WLAN tester to determine the packet error rate (PER) by counting the number of ACK control frames received from the EUT in response to repeated unicast data packets transmitted by the WLAN tester. No other traffic generation shall be enabled during this test. The PER is generally defined as the ratio of packets lost divided by the number of packets transmitted to the EUT. For the purposes of this test plan, the PER is defined at the WLAN tester as the ratio of (Packets Sent – ACKs Received) / Packets Sent, or (1 – ACKs Received / Packets Sent). Receiver Sensitivity measurements shall be performed using the calibrated WLAN tester to determine the EUT's receiver sensitivity by reporting the minimum forward-link power resulting in a PER of 10% or less with 95% confidence. The sensitivity is reported as the last passing power level measured within 1 dB of the target sensitivity level. The system shall be configured as specified in [Section 3.1.4](#) with the exception of the changes specified in [Table 3.1-4](#).

TABLE 3.1-4 PARAMETER SETTINGS FOR RECEIVER SENSITIVITY TEST

Parameter		Value
Interval between packets (ms)*		1
Packet size (bytes)	802.11a/b/g/n	1000**
Min number of packets		1000
<p>*Note: If the device is not capable of responding reliably to packets at the 1 ms interval, this time interval may be increased as required; indicate the used interval size in the test report.</p> <p>**Note: If a device does not support the required packet size, use the maximum supported and indicate the used packet size in the test report.</p>		

3.1.6 Results

Results shall be reported in dBm.

There are no Pass/Fail criteria. Refer to [Appendix A](#) for sample report templates.

Section 4 Radiated Measurements

4.1 Wi-Fi Total Radiated Measurements (TRP/TIS)

4.1.1 Test Purpose

The purpose of this test is to measure the Total Radiated Power and Total Isotropic Sensitivity of the Wi-Fi transceiver in the device.

4.1.2 Test Setup

Typical system schematics for both TRP and TIS measurements are shown in the following figures. The configurations shown are only representative examples of test systems configuration.

Figure 4.1-1 shows a configuration where both uplink and downlink communications are transmitted through the measurement antenna. This configuration does not support independent amplification of both signal paths if necessary.

FIGURE 4.1-1 SIMPLIFIED BLOCK DIAGRAM SHOWING A COMMON CONFIGURATION FOR TRP/TIS MEASUREMENT

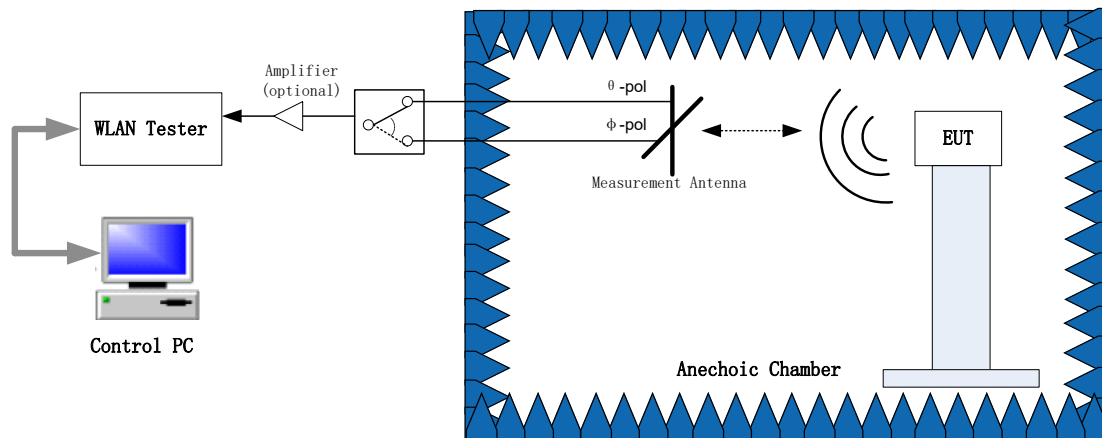

Figure 4.1-2 shows a simplified block diagram showing a configuration for TRP measurement. The uplink communication is transmitted through the measurement antenna and the downlink is transmitted through the link antenna. This configuration supports amplification of both signal paths if necessary.

FIGURE 4.1-2 SIMPLIFIED BLOCK DIAGRAM SHOWING A CONFIGURATION FOR TRP MEASUREMENT

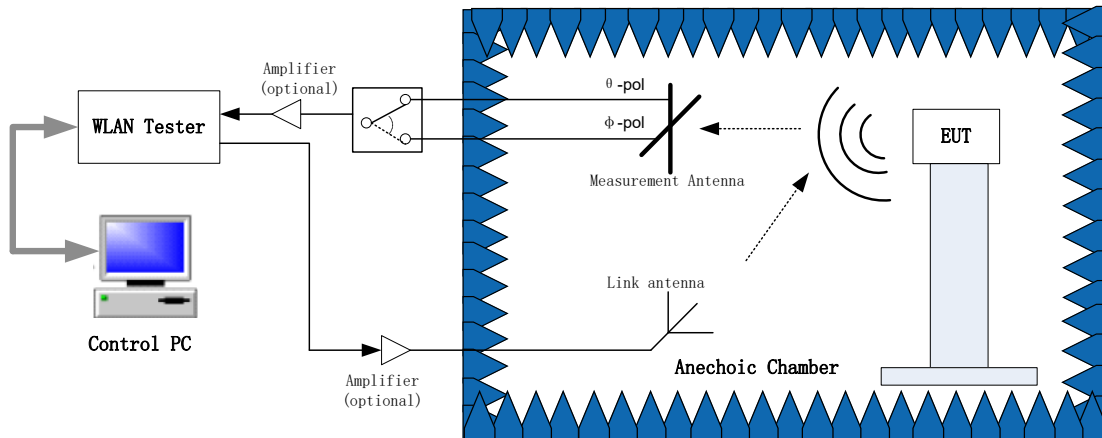
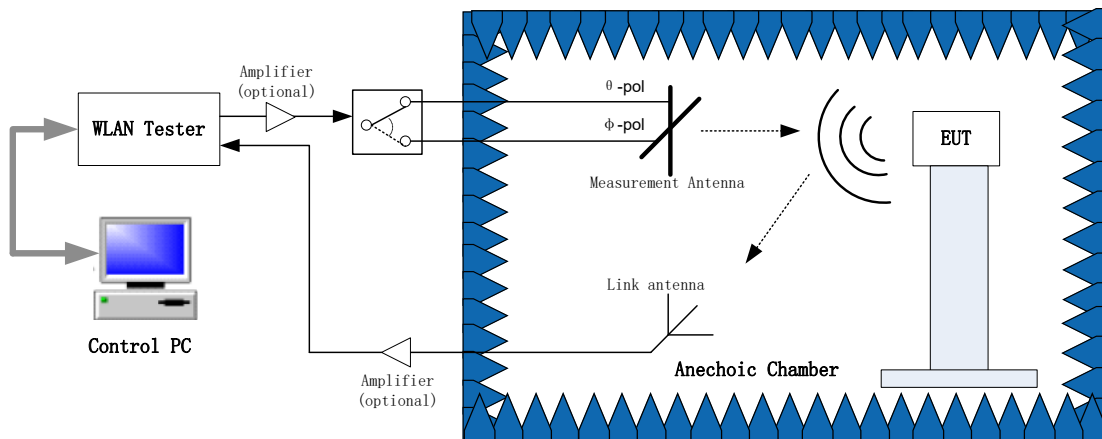

Figure 4.1-3 shows a simplified block diagram showing a configuration for TIS measurement. The downlink communication is transmitted through the measurement antenna and the uplink is transmitted through the link antenna. This configuration supports amplification of both signal paths if necessary.

FIGURE 4.1-3 SIMPLIFIED BLOCK DIAGRAM SHOWING A CONFIGURATION FOR TIS MEASUREMENT



For more information about possible test setup configurations and details, refer to Appendix A of the CTIA OTA Test Plan [1] for setup illustrations.

4.1.3 Measurement Frequencies for Radiated Tests

For 2.4 GHz IEEE 802.11b/g/n devices, the TRP/TIS measurement is made on Channel 6.

For 5 GHz IEEE 802.11a/n devices, the TRP/TIS measurement is made on the middle channels.

Table 4.1-1 lists the TIS/TRP measurement channels for IEEE 802.11a and n commonly supported sub-band cases.

TABLE 4.1-1 TIS/TRP MEASUREMENT CHANNELS FOR IEEE 802.11A AND N SUPPORTED SUB-BANDS

Sub Band	Channel Range	TIS/TRP Channel
UNII Low Band	36 to 48	44
UNII Middle Band	52 to 64	60
ETSI European band	100 to 140	120
UNII Upper Band	149 to 161	157
USA	165	165

4.1.4 Test Procedure for Total Radiated Power Measurement

This test procedure is primarily based on the TRP measurement procedure specified in the CTIA Test Plan [1]. For more details, please refer to the procedure specified in CTIA OTA Test Plan [1] Sections 2 and 5 for TRP measurement.

In order to obtain accurate results of radiated performance of Wi-Fi, it is necessary to perform a range reference measurement to account for the various factors affecting the measurement of these quantities. These factors include components like range length, path loss, gain of the receive antenna, cable losses, and so forth. Please refer to CTIA OTA Test Plan [1] Section 4 for more details.

A calibrated WLAN tester capable of maintaining the connection over the air is required. The WLAN tester or other applicable power measurement device (e.g. signal analyzer) is used to provide traceable power measurements. For TRP measurements, use the same parameter settings as specified in Section 3.1.4.

For client devices, the tester is typically configured as an AP, although ad-hoc mode may also be used to communicate with the EUT. The tester shall be configured to the channel (frequency) to be tested as specified in Section 4.1.3. The tester shall be configured for the data rate to be tested as specified in Section 0. Additional tester settings may also be needed to ensure that the EUT responds at the target data rate.

For access points and devices acting as mobile access points, the tester is configured as a client. In this case, the EUT shall typically be configured for the channel to be tested as specified in Section 4.1.3. The tester shall be configured for the data rate to be tested as specified in Section 0. Additional tester or EUT settings may also be needed to ensure that the EUT responds at the target data rate.

Capture measurement results. See Appendix A for recommended data reporting format.

Note: The test lab may choose to use Alternative Test Procedures as specified in CTIA OTA Test Plan [1] Section 5.11.

For devices supporting multiple Wi-Fi TX antennas, guidelines specified in Section 5.14 “OTA Testing of Devices Containing Multiple TX Antennas” of the CTIA OTA Test Plan [1] shall be used.

4.1.5 Test Procedure for Total Isotropic Sensitivity Measurement

The test procedure is primarily based on the TIS measurement procedure specified in the CTIA OTA Test Plan [1]. For more details, please refer to the procedure specified in CTIA OTA Test Plan [1] Sections 2 and 6 for TIS measurement.

In order to obtain accurate results of radiated performance of Wi-Fi, it is necessary to perform a reference measurement to account for the various factors affecting the measurement of these quantities. These factors include components like range length, path loss, gain of the receive antenna, cable losses, and so forth. Please refer to CTIA OTA Test Plan [1] Section 4 for more details.

A calibrated WLAN tester capable of maintaining the connection over the air is required. For TIS measurement, configure the WLAN tester as specified in Section 3.1.5 with the exception of parameters specified in Table 4.1-2.

TABLE 4.1-2 PARAMETER SETTINGS FOR RECEIVER SENSITIVITY TEST

Parameter	Value
Min number of packets	100

Note: The test lab may choose to use RSSI based Alternative Test Procedures as specified in CTIA Test Plan [1] Section 6.15.

For devices supporting Antenna Switched RX Diversity for Wi-Fi, guidelines specified in Section 6.19 “OTA Testing of Devices with RX Antenna Switching” of the CTIA OTA Test Plan [1] shall be used.

4.1.6 TRP Data Rates

For each of the channels specified in Section 4.1.3, the transmit power output shall be measured at the data rates given in Table 3.1-1.

For devices which have more than one protocol in the same frequency band, such as 802.11b/g/n or 802.11a/n, an alternate test procedure to determine the offset in TRP between different protocols on equivalent channels can be used by referring to CTIA OTA Test Plan [1] Section 5.11 Alternate Test Procedure for TRP.

4.1.7 TIS Data Rates

For each of the channels specified in Section 4.1.3, the receive sensitivity shall be measured at the following data rates:

TABLE 4.1-3 RECEIVER SENSITIVITY TEST DATA RATES

Band	Protocol (Mode)	Test Data Rate (Mbps)
2.4GHz	IEEE 802.11b	11
	IEEE 802.11g	54
	IEEE 802.11n	65
5GHz	IEEE 802.11a	54
	IEEE 802.11n	65

For devices which have more than one protocol in the same frequency band, such as 802.11b/g/n or 802.11a/n, an alternate test procedure to determine the offset in TIS between different protocols on

equivalent channels can be used by referring to CTIA OTA Test Plan [1] Section 6.15, Alternate Test Procedure for TIS.

4.1.8 Results

Results shall be reported in dBm.

There are no Pass/Fail criteria. Refer to [Appendix A](#) for sample report templates.

4.2 Wi-Fi Desense Measurements with Cellular Transmitter ON

4.2.1 Test Purpose

The following measurements measure the desensitization of the Wi-Fi radio when the Cellular radio is operating.

4.2.2 Test Setup

Typical system diagrams for Wi-Fi Desense measurements are shown in [Figure 4.2-1](#) and [Figure 4.2-2](#). The configurations shown are only representative examples of common systems and do not represent an exhaustive list of possible configurations.

[Figure 4.2-1](#) is a simplified block diagram showing a common configuration for Wi-Fi desense measurements.

FIGURE 4.2-1 SIMPLIFIED BLOCK DIAGRAM SHOWING A COMMON CONFIGURATION FOR WI-FI DESENSE MEASUREMENTS

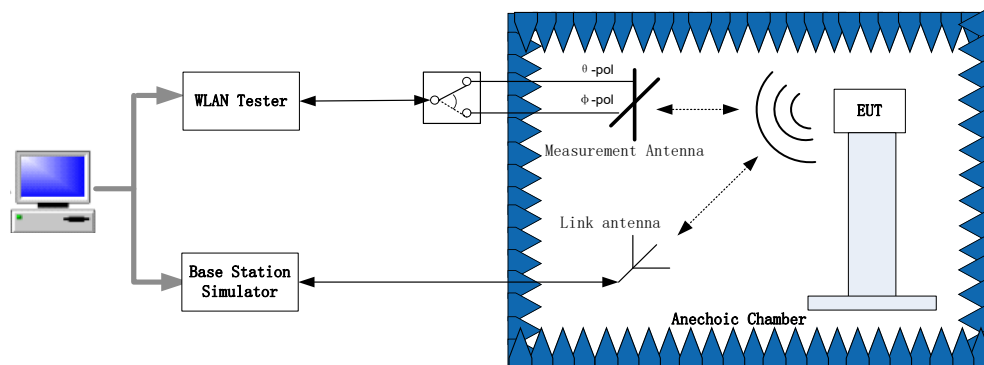

[Figure 4.2-2](#) shows a simplified block diagram showing another common configuration for Wi-Fi desense measurements.

FIGURE 4.2-2 SIMPLIFIED BLOCK DIAGRAM SHOWING ANOTHER COMMON CONFIGURATION FOR WI-FI

DESENSE MEASUREMENTS

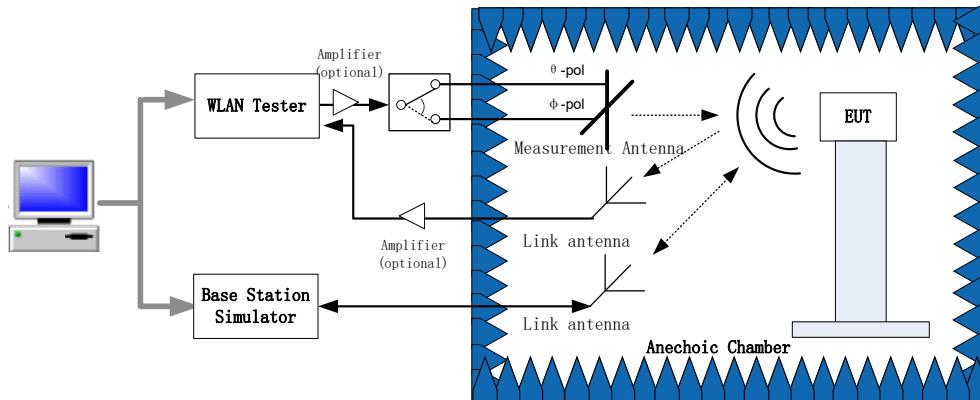

For more information about possible test setup configurations and details, refer to [Appendix A](#) of the CTIA OTA Test Plan [1] for setup illustrations.

4.2.3 Test Procedures for Wi-Fi Radio Desensitization

The Wi-Fi desensitization tests consist of two groups of test scenarios related to the desensitization by closest cellular uplink frequency and desensitization by cellular uplink harmonics. Section 4.2.4 covers the test scenario and details for the closest cellular uplink frequency case while Section 4.2.5 covers the details related to the cellular uplink harmonics.

All cellular Tx parameter settings shall be set according to Section 5 of the CTIA OTA Test Plan [1] or [Appendix C](#).

For the Wi-Fi desensitization tests, configure the test as specified in Section 4.1.5 for the TIS (both cellular downlink and EUT cellular are disabled) testing with the exception of the setup corresponding to the desensitizing cellular signal that is specified here. Desense measurements shall be made at the same data rates used for the TIS measurements of Section 4.1.5.

The Wi-Fi desensitization test consists of four basic steps as follows:

1. The EUT and chamber positioner(s) are moved to the location & polarization resulting in the best-radiated free-space sensitivity (EIS) measured for the closest, in frequency, channel for which the TIS has been determined, as covered in Section 4.1.5.
2. For the Wi-Fi channels specified in Sections 4.2.4 or 4.2.5, perform a single EIS measurement using the number of packets specified in [Table 4.2-1](#).

TABLE 4.2-1 PARAMETER SETTINGS FOR WI-FI RADIO DESENSITIZATION TEST

Parameter	Value
Min number of packets	1000

3. Enable the cellular radio in the EUT and establish a cellular connection to turn on the cellular interferer and repeat for all interfering channels specified in Sections 4.2.4 or 4.2.5.
4. Subtract the EIS measured in Step 2 from the EIS measured in Step 3 and report the results as the resulting desensitization. An example result table is given in [Appendix A](#).

Depending on the details of the equipment used to conduct the tests there will be a limit to which desensitization can be measured. The search for the desense level shall be continued until a passing error rate is achieved or the test system limit is reached. If the EUT reaches this limit and the actual value cannot be measured, record the max EIS that the test system can produce and indicate that the limit was reached in the test report. The test equipment should be capable of measuring a desense level of 40 dB or more.

[Appendix F](#) lists the RATs considered in the construction of the interfering signal for these tests. If a Test Lab is presented with a device containing a RAT that is not listed, the test Lab shall contact certifications@Wi-Fi.org for clarification.

The test cases applicable to TD-SCDMA are not required for CTIA and PTCRB certification. The UE manufacturer shall declare if TD-SCDMA is required for testing based on the requirements for other certification bodies and/or regional requirements. The applicability of TD-SCDMA should be made with input from the target operators.

For devices supporting multiple cellular TX antennas, Wi-Fi radio desensitization shall be tested with the cellular TX antennas configured per the guidelines specified in Section 5.14 "OTA Testing of Devices Containing Multiple TX Antennas" of the CTIA OTA Test Plan [1].

NOTE: This could require multiple tests if the conditions of Section 5.14.1 of the CTIA OTA Test Plan [1] apply.

4.2.4 Wi-Fi Radio Desensitization by Closest Cellular Uplink Frequency

A cellular radio transmitter in the converged device can overload the front-end of the Wi-Fi radio, or desensitize it by an out of band emission. This can happen at any cellular frequency but is usually most prevalent at cellular frequencies closest to the Wi-Fi bands.

Desensitization of the lowest Wi-Fi channel, Channel 1, shall be measured for all RATs supported by the device whose Tx frequencies (the center of the highest channel or the center of the allocated resource blocks at the upper edge of the highest channel for LTE as specified by the CTIA OTA Test Plan [1]) fall between 1880 MHz and 2400 MHz. The measurement shall be made with the closest Tx channel (and uplink RB allocation for LTE) to Wi-Fi Channel 1.

Desensitization of the highest supported Wi-Fi channel (for example, Channel 11 or Channel 13) shall be measured for all RATs supported by the device whose Tx frequencies (the center of the lowest channel or the center of the allocated resource blocks at the lower edge of the lowest channel for LTE as specified by the CTIA OTA Test Plan [1]) fall between 2483.5 MHz and 3003.5 MHz. The measurement shall be made with the closest Tx channel (and uplink RB allocation for LTE) to highest supported Wi-Fi channel.

Choose the combinations with minimum frequency offset in [Table 4.2-2](#) depending on what Wi-Fi channels and cellular RATs the DUT supports.

If the device supports more than one band with the same RAT, then only the closest frequency (which is either the center of the channel or center of the resource blocks for LTE as specified by the CTIA OTA Test Plan [1]) to the 2400 MHz Wi-Fi band shall be tested.

All modes b, g and n (if supported by the Wi-Fi radio) shall be tested.

TABLE 4.2-2 CLOSEST CHANNEL COMBINATIONS

Wi-Fi Radio Desensitization by Closest Cellular Uplink Frequency								
Wi-Fi Channel Number	Wi-Fi Channel Frequency (MHZ)	Cellular RAT	Channel Bandwidth (MHz)	RAT Channel Number	RAT Uplink Frequency (MHz)	Call Setup Reference	Special Setup	Frequency Gap (MHz)
1	2412	CDMA PCS 1900 BC1	-	1175	1908.75	CTIA OTA Test Plan [1]		503.25
		GSM1900	-	810	1909.80	CTIA OTA Test Plan [1]		502.20
		WCDMA Band I	-	9888	1977.60	CTIA OTA Test Plan [1]		434.40
		WCDMA Band II	-	9538	1907.60	CTIA OTA Test Plan [1]		504.40
		LTE Band 1	10	18550	1983.42	CTIA OTA Test Plan [1]	12 RB with RBstart = 38	428.58
		LTE Band 2	10	19150	1908.42	CTIA OTA Test Plan [1]	12 RB with RBstart = 38	503.58
		LTE Band 25	5	26665	1914.03	CTIA OTA Test Plan [1]	8 RB with RBstart = 17	497.97
		LTE Band 30	10	27710	2313.42	CTIA OTA Test Plan [1]	12 RB with RBstart = 38	98.58
		LTE Band 39	20	38550	1917.38	CTIA OTA Test Plan [1]	18 RB with RBstart = 82	494.62
		LTE Band 40	20	39550	2397.38	CTIA OTA Test Plan [1]	18 RB with RBstart = 82	14.62

Wi-Fi Radio Desensitization by Closest Cellular Uplink Frequency								
Wi-Fi Channel Number	Wi-Fi Channel Frequency (MHZ)	Cellular RAT	Channel Bandwidth (MHz)	RAT Channel Number	RAT Uplink Frequency (MHz)	Call Setup Reference	Special Setup	Frequency Gap (MHz)
		TD-SCDMA Band A	-	10121	2024.20	CTIA OTA Test Plan [1]		387.80
		TD-SCDMA Band F	-	9496	1899.20	CTIA OTA Test Plan [1]		512.80
11	2462	LTE Band 7	20	20850	2502.62	CTIA OTA Test Plan [1]	18 RB with RBstart = 0	40.62
		LTE Band 38	20	37850	2572.62	CTIA OTA Test Plan [1]	18 RB with RBstart = 0	110.62
		LTE Band 41	20	39750	2498.62	CTIA OTA Test Plan [1]	18 RB with RBstart = 0	36.62
13	2472	LTE Band 7	20	20850	2502.62	CTIA OTA Test Plan [1]	18 RB with RBstart = 0	30.62
		LTE Band 38	20	37850	2572.62	CTIA OTA Test Plan [1]	18 RB with RBstart = 0	100.62
		LTE Band 41	20	39750	2498.62	CTIA OTA Test Plan [1]	18 RB with RBstart = 0	26.62
14*	2484	LTE Band 7	20	20850	2502.62	CTIA OTA Test Plan [1]	18 RB with RBstart = 0	18.62
		LTE Band 38	20	37850	2572.62	CTIA OTA Test Plan [1]	18 RB with RBstart = 0	88.62
		LTE Band 41	20	39750	2498.62	CTIA OTA Test Plan [1]	18 RB with RBstart = 0	14.62

(*) For devices supporting Channel 14, Wi-Fi desense in 802.11b will be tested on Channel 14.

Example – Device 1

- 4 band GSM (1900, 1800, 900, 850),
- 5 band WCDMA (Bands I, II, IV, V, VIII),
- 5 band LTE (2, 4, 5, 13, 17)
- 802.11 a, b, g, n (Channels 1-11 supported @ 2400 MHz).

Bands and RATs within 520 MHz of Wi-Fi for this device are:

- WCDMA Band I (high channel - 9888, Tx uplink = 1977.60 MHz) and
- WCDMA Band II (high channel – 9538, Tx uplink = 1907.60 MHz)
- LTE Band 2 (high channel - 19150, 1908.42 MHz @ center of uplink RB allocation)
- GSM 1900 (high channel – 810, 1909.80 MHz)

Set Wi-Fi to lowest supported channel, Channel 1, 2412 MHz, for b/g/n modes.

Test the following

- Wi-Fi Channel 1 against GSM 1900 Channel 810, 1909.80 MHz
- Wi-Fi Channel 1 against WCDMA Band I Channel 9888, 1977.60 MHz
- Wi-Fi Channel 1 against LTE Band 2 Channel 19150, 1908.42 MHz, center of uplink RB allocation

WCDMA Band II is also within the range, but its uplink frequency (1907.6 MHz, Channel 9538) is lower in frequency than WCDMA Band I and the same RAT does not need to be tested again.

Example – Device 2

- Single band LTE TDD Band 41 device and 802.11 b, g, n (Channels 1-11).

Bands and RATs within 520 MHz of Wi-Fi for this device are:

- LTE TDD Band 41 (low channel, 39750, 2498.62 MHz @ center of uplink RB allocation).

Set Wi-Fi to highest supported channel, Channel 11, 2462 MHz, for b/g/n modes.

Test the following

- Wi-Fi Channel 11 against LTE TDD Band 41 Channel 39750, 2498.62 MHz @ center of uplink RB allocation

4.2.5 Wi-Fi Radio Desensitization by Cellular Radio Uplink Harmonics

The cellular transmitter can produce unwanted harmonics that may interfere with certain Wi-Fi channels depending upon the combination of cellular technologies and Wi-Fi channels implemented in a converged device. [Appendix F](#) shows all known RATs and their interaction with Wi-Fi channels and many other details in a large spreadsheet. A subset of Wi-Fi channels has been selected that cover the interaction with as many RATs as possible to simplify the test selection and these are compiled into [Table 4.2-3](#).

The EUT desensitization shall be tested for all relevant interactions in [Table 4.2-3](#). The cellular radio configuration will be set according to the Call Setup Reference, in [Table 4.2-3](#), except for those parameters specifically defined within the table. Relevant interaction is defined by supported RAT implementation or as specified by the manufacturer.

TABLE 4.2-3 DESENSITIZATION CASES

Cellular RAT & Wi-Fi channel pairs for Testing Harmonic Desensitization of Wi-Fi by Cellular Uplink Tx						
Wi-Fi Channel	Test Case	Cellular RAT	RAT Channel Number	RAT Uplink Frequency (MHz)	Call Setup Reference	Special Setup
11	11.1	GSM 850	128	824.2	CTIA OTA Test Plan [1]	
	11.2	CDMA 800 Cellular BC0	1013	824.7	CTIA OTA Test Plan [1]	
	11.3	WCDMA 850 3GPP Band V	4132	826.4	CTIA OTA Test Plan [1]	
	11.4	LTE Band 5 (not needed if LTE Band 26 is tested)	20450	825.58	CTIA OTA Test Plan [1]	10.0 MHz BW, UL: 12 RB, RBstart = 0
	11.5	LTE Band 26	26815	824.97	CTIA OTA Test Plan [1]	5.0 MHz BW, UL: 8 RB, RBstart=0
13	13.1	GSM 850	128	824.2	CTIA OTA Test Plan [1]	
	13.2	CDMA 800 Cellular BC0	1013	824.7	CTIA OTA Test Plan [1]	
	13.3	WCDMA 850 3GPP Band V	4132	826.4	CTIA OTA Test Plan [1]	
	13.4	LTE Band 5(not needed if LTE Band 26 is tested)	20450	825.58	CTIA OTA Test Plan [1]	10.0 MHz BW, UL: 12 RB, RBstart = 0
	13.5	LTE Band 26	26815	824.97	CTIA OTA Test Plan [1]	5.0 MHz BW, UL: 8 RB, RBstart=0
44	44.1	DCS 1800	661	1740.0	CTIA OTA Test Plan [1] Appendix M	
	44.2	WCDMA 3GPP Band III	1075	1740.0	CTIA OTA Test Plan [1] Appendix M	

	44.3	WCDMA 2100/1700 3GPP Band IV	1450	1740.0	CTIA OTA Test Plan [1]	
	44.4	LTE Band 3	19534	1739.98	CTIA OTA Test Plan [1] Appendix M	10 MHz BW, UL: 12 RB, RBstart=0
	44.5	LTE Band 4	20284	1739.98	CTIA OTA Test Plan [1]	10 MHz BW, UL: 12 RB, RBstart=0
	44.6	LTE Band 38	38150	2610.02	Appendix C	20 MHz BW, UL: 18 RB, RBstart=0
	44.7	LTE Band 41	40864	2610.02	CTIA OTA Test Plan [1]	20 MHz BW, UL: 18 RB, RBstart=0
60	60.1	DCS 1800	794	1766.6	CTIA OTA Test Plan [1] Appendix M	
	60.2	CDMA 1800 BC 15	334	1766.7	CTIA OTA Test Plan [1]	
	60.3	WCDMA 3GPP Band III	1208	1766.6	CTIA OTA Test Plan [1] Appendix M	
	60.4	LTE Band 3	19800	1766.58	CTIA OTA Test Plan [1] Appendix M	10 MHz BW, UL: 12 RB, RBstart=0
	60.5	LTE Band 41	41264	2650.56	CTIA OTA Test Plan [1]	20 MHz BW, UL: 18 RB, RBstart=0
124	124.1	GSM 1900	628	1873.4	CTIA OTA Test Plan [1]	
	124.2	CDMA 1900 PCS BC1	468	1873.4	CTIA OTA Test Plan [1]	
	124.3	WCDMA 1900 3GPP Band II	9367	1873.4	CTIA OTA Test Plan [1]	
	124.4	LTE Band 2 (not needed if LTE Band 25 is tested)	18866	1873.18	CTIA OTA Test Plan [1]	10 MHz BW, UL: 12 RB, RBstart=0

	124.5	LTE Band 25	26287	1873.17	CTIA OTA Test Plan [1]	5 MHz BW, UL: 8 RB, RBstart=0
132	132.1	TD-SCDMA Band F1	9436	1887.2	Appendix C	
140	140.1	LTE Band 39	38524	1900.0	Appendix C	20 MHz BW, UL: 18 RB, RBstart=0
	140.2	TD-SCDMA Band F2	9492	1898.4	Appendix C	
157	157.1	CDMA 2000 BC 6	167	1928.4	CTIA OTA Test Plan [1]	
	157.2	WCDMA 3GPP Band I	9642	1928.4	CTIA OTA Test Plan [1] Appendix M	
	157.3	LTE Band 1	18118	1928.38	CTIA OTA Test Plan [1] Appendix M	10 MHz BW, UL: 12 RB, RBstart=0

Example – Device 1

- 4 band GSM (1900, 1800, 900, 850),
- 5 band WCDMA (Bands I, II, IV, V, VIII),
- 5 band LTE (2, 4, 5, 13, 17)
- 802.11 b, g, n (Channels 1-11 supported @ 2400 MHz).
- 802.11 a Channels 36 – 64

Test the following:

- Wi-Fi Channel 11 against GSM 850 Channel 128, 824.2 MHz
- Wi-Fi Channel 11 against WCDMA 850 3GPP Band V Channel 4357, 826.4 MHz
- Wi-Fi Channel 11 against LTE Band 5 Channel 20450, 825.6 MHz
- Wi-Fi Channel 44 against DCS 1800 GSM 1800 Channel 661, 1740.0 MHz
- Wi-Fi Channel 44 against WCDMA 3GPP Band III Channel 1300, 1740.0 MHz
- Wi-Fi Channel 44 against LTE Band 4 Channel 20250, 1740.0 MHz
- Wi-Fi Channel 60 against DCS 1800 GSM 1800 Channel 794, 1766.6 MHz

Example – Device 2

- Single band LTE TDD Band 41 device and 802.11 b, g, n (Channels 1-11).

No test is required.

4.2.6 Results

Results shall be reported in dB.

There are no Pass/Fail criteria. Refer to [Appendix A](#) for sample report templates.

4.3 Cellular Desense Measurements with Wi-Fi transmitter ON

4.3.1 Test Purpose

The purpose of this test is to conduct cellular desensitization test when the EUT's Wi-Fi transmitter is ON.

4.3.2 Test Setup

[Figure 4.3-1](#) shows an example test system configuration for the cellular desense measurement.

All desense tests of this section are performed in Free Space condition.

FIGURE 4.3-1 EXAMPLE TEST SYSTEM CONFIGURATION FOR CELLULAR DESENSE MEASUREMENTS

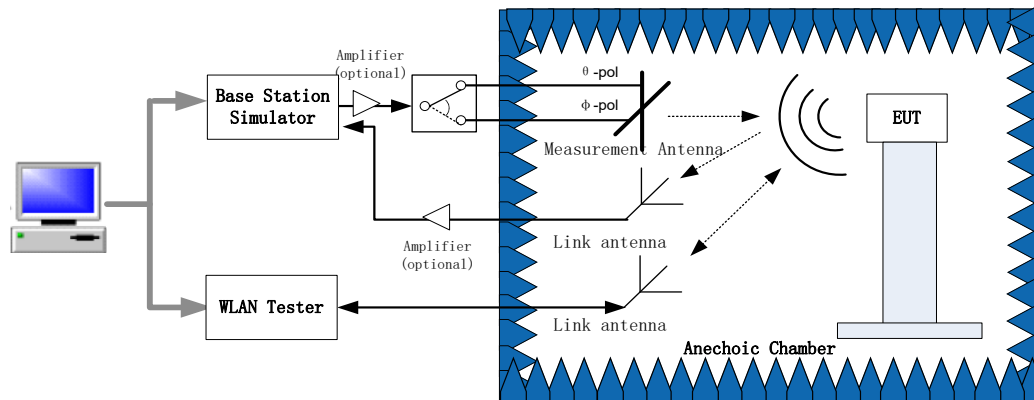

For more information about possible test setup configurations and details, refer to Appendix A of the CTIA OTA Test Plan [1] for setup illustrations.

For Wi-Fi EUT transmitter stimulus, unicast UDP packets are transmitted by the WLAN tester using the MAC address of the Wi-Fi EUT. The RF port of the WLAN tester is connected to the link antenna inside the chamber.

For this test, ACK based packet generation shall be used to create the Wi-Fi interference signal. The ACK control frames are sent in response to unicast data packets generated by the WLAN tester according to the parameters specified in [Table 3.1-4](#). The EUT will respond with repeated ACKs which will be transmitted at maximum power.

Cellular desense tests shall only be performed with 802.11b, 2.4 GHz (if 802.11b is not supported, then use 802.11g, if 802.11b/g is not supported, then use 802.11n) and 802.11a, 5 GHz (unless the device only supports 802.11n, then use 802.11n). Data rates of [Table 3.1-1](#) shall be used for the Wi-Fi interference signal.

All desense tests of this section are performed according to the configurations specified in Appendix B.

For devices supporting multiple Wi-Fi TX antennas, cellular radio desensitization shall be tested with the Wi-Fi TX antennas configured per the guidelines specified in Section 5.14 "OTA Testing of Devices Containing Multiple TX Antennas" of the CTIA OTA Test Plan [1]. NOTE: This could require multiple tests if the conditions of Section 5.14.1 of the CTIA OTA Test Plan [1] apply.

4.3.3 Test Procedure for GSM, CDMA and UMTS RATs listed in the CTIA OTA Test Plan

For GSM, CDMA and UMTS RATs listed in CTIA OTA Test Plan [1] Section 6, perform the following steps. If Appendix O.3, O.4 and O.5 of the CTIA OTA Test Plan [1] allows for reduced legacy RAT testing for TIS and/or intermediate channel testing in free-space, the same test reduction is allowed for the same non-LTE RAT.

Initial Conditions

1. Turn on the Wi-Fi radio and let the Wi-Fi EUT associate with the WLAN tester using appropriate settings of the EUT and WLAN tester.
2. Start Wi-Fi EUT Transmitter Stimulus as specified in Section 4.3.2.

Test Procedures

3. With Wi-Fi Radio on, perform the Relative Sensitivity on Intermediate Channels test at all intermediate channels according to the appropriate Receive Performance Test Procedure section of the CTIA OTA Test Plan [1].
4. Compare the resulting digital error rate or throughput rate as specified in the CTIA OTA Test Plan [1] and determine which channels are desensitized beyond requirements specified in the CTIA OTA Test Plan [1].
5. Repeat Step 3 and Step 4 for all RATs and corresponding supporting bands.
6. Report only the intermediate channels that exceed the limit as specified in the CTIA OTA Test Plan [1].

4.3.4 Test Procedure for RATs without Free-Space Limits

For RATs without reference free-space TIS limits, the test for relative sensitivity on intermediate channels, as defined in Section 6 of the CTIA OTA Test Plan [1], cannot be performed because M1 margin values cannot be determined. In that case, the procedure listed here shall be followed. This includes all LTE RATs (see Section 6.8.2 and Appendix O.10.1 “LTE Relative Sensitivity on Intermediate Channels Test” of the CTIA OTA Test Plan [1]) until such time as limits are established, as well as those RATs listed in Appendix C here and any RATs listed in the CTIA OTA Test Plan [1] Appendix M.

If Appendix O.3, O.4 and O.5 of the CTIA OTA Test Plan [1] allows for reduced legacy RAT testing for TIS and/or intermediate channel testing in free-space, the same test reduction is allowed for the same non-LTE RAT.

The test cases applicable to TD-SCDMA are not required for CTIA and PTCRB certification. The UE manufacturer shall declare if TD-SCDMA is required for testing based on the requirements for other certification bodies and/or regional requirements. The applicability of TD-SCDMA should be made with input from the target operators.

Test Procedures

1. Determine the TIS of the EUT at the low channel with the Wi-Fi radio transmitter switched OFF, using the data captured previously per the procedures in the CTIA OTA Test Plan [1].
2. Use the CTIA OTA Test Plan [1] procedures to determine the position and polarization that results in the maximum EIS value associated to Step 1.
3. Use the corresponding position and polarization of Step 2 and measure the EIS(peak) of the EUT at the low channel with the Wi-Fi radio transmitter switched OFF.
4. Capture the measured EIS result as Value A Low.

5. Turn on the Wi-Fi radio and let the Wi-Fi EUT associate with the WLAN tester using appropriate settings of the EUT and WLAN tester.
6. Start Wi-Fi EUT Transmitter Stimulus as specified in Section 4.3.2.
7. Without re-positioning and keeping the same corresponding position and polarization of Step 2, measure the EIS(peak) of the EUT at the low channel with the Wi-Fi radio transmitter switched ON. Capture the result as Value B Low.
8. Repeat Step 1 to Step 7 for the mid and high channels.
9. Repeat Step 1 to Step 8 for all RATs and corresponding supporting bands.

4.3.5 Test Procedure for all LTE cases

Note: The CTIA OTA Test Plan [1] includes a list of LTE intermediate channels for Northern American bands in Section O.10.1 “LTE Relative Sensitivity on Intermediate Channels Test”, however, no M1 margin values are available as the test plan does not currently specify minimum TIS requirements for LTE devices.

For all LTE RATs perform the following steps.

Test Procedures

Follow the procedure of Section 4.3.4.

4.3.6 Wi-Fi Frequency

Devices that operate in the 2.4 GHz band shall be set to operate on Channel 6 ($f_c = 2.437$ GHz). Devices that operate in the 5 GHz band shall be set to operate only on the middle channel of the lowest frequency supported sub-band. The Middle Channel numbers corresponding to each sub-band are listed in Table 4.3-1.

TABLE 4.3-1 MIDDLE CHANNELS FOR WI-FI U-NII SUB-BAND FOR TIS CELLULAR DESENSE

Sub Band	Middle Channel #	Middle Channel Center Frequency f_c
U-NII Lower Band (5.15 GHz to 5.25 GHz)	44	5.220 GHz
U-NII Middle Band (5.25 GHz to 5.35 GHz)	60	5.300 GHz
U-NII Upper Band (5.725 GHz to 5.825 GHz)	157	5.785 GHz
European ETSI Band	120	5.600 GHz

4.3.7 Error Rate Measure

According to the CTIA OTA Test Plan [1], each cellular protocol (such as GSM, CDMA, and UMTS) specifies a different digital error rate as the EUT cellular receiver performance metric, while LTE FDD/ LTE TDD specify the measurement of the EUT cellular receiver’s throughput rate as the applicable performance metric. The error rates or throughput values shall be applied to all bands as specified in the CTIA OTA Test Plan [1] and Appendix C of this specification.

4.3.8 Results

There are no Pass/Fail criteria.

When performing the test according to Section 0, results shall be reported by giving the channel(s) exceeding the limit. When performing the test according to Section 4.3.4, results shall be reported in dBm for the EIS values.

Refer to [Appendix A](#) for sample report templates.

Appendix A Summary Test Report

The following content shall be included in the test report. The tables are provided as examples for information.

TABLE A-1 SAMPLE SUMMATION

Manufacturer	
Model	
Wi-Fi Alliance CID2	
CTIA Request #	
Serial Number (e.g., MEID, IMEI).	
Regulatory Approval ID (e.g., FCCID)	
Hardware Version	
Software Version	

² Vendor supplies the Wi-Fi Alliance CID (Certification Identifier) during the CWG application process.

A.1. Wi-Fi Conducted Tests

TABLE A- 1 CONDUCTED RF POWER OUTPUT AND RECEIVER SENSITIVITY RESULTS

Mode	Sub-band	Channel	Data Rate, Mbps	Output Power dBm	Receiver Sensitivity dBm
802.11b 2.4 GHz	N/A	Low	11		
		6	11		
		High	11		
802.11g 2.4 GHz	N/A	Low	6		
			54	N/A	
		6	6		
			54	N/A	
		High	6		
			54	N/A	
802.11n 2.4 GHz	N/A	Low	6.5		
			65	N/A	
		6	6.5		
			65	N/A	
		High	6.5		
			65	N/A	
802.11a 5 GHz	UNII Low Band	36	6		
			54	N/A	
		44	6		
			54	N/A	
		48	6		
			54	N/A	
802.11a 5 GHz	UNII Middle Band	52	6		
			54	N/A	
		60	6		
			54	N/A	
		64	6		
			54	N/A	
802.11a 5 GHz	ETSI European band	100	6		
			54	N/A	
		120	6		
			54	N/A	
		140	6		
			54	N/A	
802.11a 5 GHz	UNII Upper Band	149	6		
			54	N/A	
		157	6		
			54	N/A	
		161	6		
			54	N/A	

		165	6		
--	--	-----	---	--	--

802.11a 5 GHz	USA		54	N/A	
		165	6		
			54	N/A	
		165	6		
802.11n 5 GHz	UNII Low Band	36	6.5		
			65	N/A	
		44	6.5		
			65	N/A	
		48	6.5		
			65	N/A	
802.11n 5 GHz	UNII Middle Band	52	6.5		
			65	N/A	
		60	6.5		
			65	N/A	
		64	6.5		
			65	N/A	
802.11n 5 GHz	ETSI European band	100	6.5		
			65	N/A	
		120	6.5		
			65	N/A	
		140	6.5		
			65	N/A	
802.11n 5 GHz	UNII Upper Band	149	6.5		
			65	N/A	
		157	6.5		
			65	N/A	
		161	6.5		
			65	N/A	
802.11n 5 GHz	USA	165	6.5		
			65	N/A	
		165	6.5		
			65	N/A	
		165	6.5		
			65	N/A	

A.2. Total Radiated Power (TRP) and Total Isotropic Sensitivity (TIS) for 2.4 GHz 802.11b, 802.11g and 802.11n

TABLE A- 2 TRP FOR 2.4 GHZ 802.11B/G/N

Mode	Channel	Data Rate, Mbps	Result, dBm TRP
IEEE 802.11b	6	11	
IEEE 802.11g	6	6	
IEEE 802.11n	6	6.5	

TABLE A- 3 TIS FOR 2.4 GHZ 802.11B/G/N

Mode	Channel	Data Rate, Mbps	Result, dBm TIS
IEEE 802.11b	6	11	
IEEE 802.11g	6	54	
IEEE 802.11n	6	65	

A.3. Total Radiated Power (TRP) and Total Isotropic Sensitivity (TIS) for 802.11a and 802.11n

Table A-5 and Table A-6 below provide the list of sub band options and corresponding channel frequency and data rates scenarios for TRP and TIS.

TABLE A- 4 TRP FOR 5 GHZ 802.11A/N

Sub Band	Channel	Data Rate, Mbps	Result, dBm TRP
UNII Low Band	44	6	
		6.5	
UNII Middle Band	60	6	
		6.5	
ETSI European band	120	6	
		6.5	
UNII Upper Band	157	6	
		6.5	
USA	165	6	
		6.5	

TABLE A-5 TIS FOR 5 GHZ 802.11A/N

Sub Band	Channel	Data Rate, Mbps	Result, dBm TIS
UNII Low Band	44	54	
		65	
UNII Middle Band	60	54	
		65	
ETSI European band	120	54	
		65	
UNII Upper Band	157	54	
		65	
USA	165	54	
		65	

A.4. Wi-Fi Desense Measurements (with cellular transmitter on)

TABLE A- 6 WI-FI RADIO DESENSITIZATION BY CLOSEST CELLULAR UPLINK FREQUENCY

802.11		Closest Cellular Uplink Frequency		802.11	Reference Polarization	Reference Position		Desense dB	Max provided EIS in case of Complete Failure dBm
Mode	Channel	Mode	Channel	Data Rate, Mbps		Theta	Phi		
802.11b									
802.11g									
802.11n 2.4 GHz									

Note: In case of complete failure, include the maximum EIS that the test system can provide in the last column; leave unused otherwise.

TABLE A- 7 WI-FI RADIO DESENSITIZATION BY CELLULAR RADIO UPLINK HARMONICS 802.11B/G/N/A

802.11		Cellular Uplink Frequency		802.11	Reference Polarization	Reference Position		Desense dB	Max provided EIS in case of Complete Failure dBm
Mode	Channel	Mode	Channel	Data Rate, Mbps		Theta	Phi		
802.11b									
802.11g									
802.11n 2.4 GHz									
802.11a 5 GHz									
802.11n 5 GHz									

Note: In case of complete failure, include the maximum EIS that the test system can provide in the last column; leave blank otherwise.

A.5. Cellular Desense Measurements (with Wi-Fi transmitter on)

Reporting Format for Intermediate Channel Sensitivity Tests according to Section 4.3.3

TABLE A- 8 CELLULAR DESENSE TEST RESULTS FOR 802.11B OPERATION (WI-FI 2.4 GHZ BAND)

Cellular Technology/ Band	Wi-Fi Channel	Reference Polarization	Reference Position Theta°	Reference Position Phi°	Intermediate Channels Exceeding Limit
	802.11b Ch. 6 (2.437GHz)				

TABLE A- 9 CELLULAR DESENSE TEST RESULTS FOR 802.11A OPERATION

Cellular Technology/ Band	Wi-Fi Channel	Reference Polarization	Reference Position Theta°	Reference Position Phi°	Intermediate Channels Exceeding Limit
	802.11a middle channel of the lowest supported sub- band				

Reporting Format for EIS Tests according to Section **Error! Reference source not found.**

TABLE A- 10 CELLULAR DESENSE TEST RESULTS FOR 802.11B OPERATION (WI-FI 2.4 GHZ BAND)

Cellular Technology Channel	Wi-Fi Channel	Reference Polarization	Reference Position Theta°	Reference Position Phi°	EIS Value A dBm			EIS Value B dBm		
					Low	Mid	High	Low	Mid	High
	802.11b Ch. 6 (2.437GHz)									

TABLE A- 11 CELLULAR DESENSE TEST RESULTS FOR 802.11A OPERATION

Cellular Technology Channel	Wi-Fi Channel	Reference Polarization	Reference Position Theta°	Reference Position Phi°	EIS Value A dBm			EIS Value B dBm		
					Low	Mid	High	Low	Mid	High
	802.11a middle channel of the lowest supported sub- band									

Appendix B Handheld Device Testing Configurations

All handheld devices shall be tested in their primary mechanical mode, as defined by the manufacturer and noted in the test report. All hand phantom guidelines with each type of wireless device shall be followed as written in the CTIA OTA Test Plan [1]. Hand phantoms meeting CTIA OTA Test Plan [1] specifications up to 3 GHz shall be used regardless of Wi-Fi operating band.

For a given device class, the test shall be performed as indicated in Table B-1. Please note that some cases require testing with multiple configurations.

TABLE B-2 DEVICE TESTING APPLICABILITY MATRIX

Device Capabilities		TIS/TRP	Wi-Fi Desense	Cellular Desense
Wi-Fi	with Simultaneous WWAN Operation	Free Space	Free Space	Free Space
	without Simultaneous WWAN Operation	Free Space	Test not Required	Test not Required
Wi-Fi Browser ³	with Simultaneous WWAN Operation	HR = Hand Right Phantom and HL = Hand Left Phantom	Free Space	Free Space
	without Simultaneous WWAN Operation	HR = Hand Right Phantom and HL = Hand Left Phantom	Test not Required	Test not Required

³ As specified in Appendix O.4 of CTIA OTA Test Plan [1].

Appendix C Radio Access Technologies that Require Testing, but are not Normative in the CTIA OTA Test Plan [1]

C.1 TD-SCDMA

The TIS measurements of TD-SCDMA shall be the same as described in the latest approved version of the CTIA OTA Test Plan [1] unless otherwise defined in this section. This section only defines differences compared to CTIA OTA Test Plan [1] and those parts shall be performed referring to 3GPP 34.114, Section 6.4. Using the Generic Call Setup procedures described in 3GPP TS 34.108 Section 7, page the EUT and place it into the loopback mode as described in 3GPP TS 34.109 Section 5.3; set the UL and DL reference measurement channel as described in 3GPP 34.122, C.2.1.2 and C.3.1.2.

Tests shall be performed for low, mid and high channels across the TD-SCDMA bands supported by the EUT, as defined in 3GPP 34.114, Section 4.1.3, Table 4.2-2 and Table 4.2-3.

C.2 LTE TDD

TIS measurements and parameter call setup of LTE TDD radio access technology shall use the same methods as described in the latest approved version of the CTIA OTA Test Plan [1] unless otherwise defined in the Table C- 1.

LTE TDD Bands 38, 39 and 40 shall be tested (in addition to the LTE TDD bands listed in the CTIA OTA Test Plan [1]).

Tests shall be performed for low, mid and high channels across the LTE TDD bands supported by the EUT, as defined in Table C- 2.

TABLE C-3 LTE TDD MEASUREMENT TABLE

Band	Channel Bandwidth (MHz)	Channel	Frequency (MHz) [center of DL RB allocation]	UL RB Allocation	DL RB Allocation
38	20	37850	2580	100RB with RBstart=0	100RB with RBstart=0
38	20	38000	2595	100RB with RBstart=0	100RB with RBstart=0
38	20	38150	2610	100RB with RBstart=0	100RB with RBstart=0
39	20	38350	1890	100RB with RBstart=0	100RB with RBstart=0
39	20	38450	1900	100RB with RBstart=0	100RB with RBstart=0
39	20	38550	1910	100RB with RBstart=0	100RB with RBstart=0

Band	Channel Bandwidth (MHz)	Channel	Frequency (MHz) [center of DL RB allocation]	UL RB Allocation	DL RB Allocation
40	20	38750	2310	100RB with RBstart=0	100RB with RBstart=0
40	20	39150	2350	100RB with RBstart=0	100RB with RBstart=0
40	20	39550	2390	100RB with RBstart=0	100RB with RBstart=0

Appendix D Notebook and Tablet Requirements

The purpose of this addendum is to define the requirements for Notebooks and Tablets with embedded WWAN and Wi-Fi radio modules.

Notebooks, Tablets, Convertible PCs and Hybrid PCs shall be tested in their primary mechanical mode based on the guidelines of Appendix L of the CTIA OTA test plan [1] and noted in the test report.

To reduce the testing of the cellular de-sense measurements with Wi-Fi Transmitter ON, data only devices shall be tested according to Table O.3 of CTIA OTA test plan [1].

D.1 Parent/Child Relationships

During product development, the Manufacturer is expected to determine what represents the most popular configuration of components and to use that configuration for the receiver performance assessment. Once the most popular version of a Parent has been identified, all Child Devices will be assessed against only that specific version of the Parent. This will hold true even if that particular version of the Parent does not remain the most popular over time.

D.2 Parent/Child Antenna Subsystem Considerations

The antenna subsystem in a Child Device must be similar in design and performance to that of its Parent (e.g. the antenna itself may be provided by a manufacturer which differs from that used in the Parent or the transmission line type/length may differ, but the antenna subsystem must be based on the same design specification).

D.3 Test Configurations and Setup Procedures

For testing configuration and setup procedures refer to CTIA OTA Test Plan [1] Appendix L. The setup configuration in Section L.4 will be used with the exception of the Transmitting Wi-Fi radio which will be “ON”.

TABLE D- 1 TEST APPLICABILITY MATRIX

Device Capabilities	Wi-Fi TRP/TIS	Wi-Fi Desense	Cellular Desense
Case 1: Simultaneous WWAN and Wi-Fi operation	Free Space	Free Space	Free Space
Case 2: WWAN and Wi-Fi not operating simultaneously	Free Space	Test not Required	Test not Required

Case 1: Notebooks and Tablets that are capable of simultaneous WWAN and Wi-Fi operation

Case 2: Notebooks and Tablets that are not capable of simultaneous WWAN/Wi-Fi operation

TABLE D- 2 DEFINITIONS

Child Device	A Notebook platform utilizing an embedded WWAN Module, which is derived from a Parent Notebook platform. A Child Device is unique in that the only allowable changes relative to its Parent product are those applicable to the Notebook platform itself.
Module	Modules are finished WWAN radio devices that do not directly connect to a host via a standardized external interface such as PCMCIA, RS-232, USB, PCIExpress, etc. A module may or may not include an integral antenna system or SIM/USIM interface.
Notebook	See definition in CTIA OTA Test Plan Error! Reference source not found. Appendix L.
Parent	A device (of any type) from which a Child device can be derived.
Simultaneous operation	A Notebook/Tablet that is capable of simultaneous Wi-Fi/Cellular operation and the user experience is that both radios are on at the same time. An example would be Hot Spot operation.
Tablet	See definition in CTIA OTA Test Plan Error! Reference source not found. Appendix L.
WLAN	Wireless Local Area Network (WLAN) links two or more devices using some wireless distribution method and usually providing a connection through an access point to the wider internet. Most modern WLANs are based on IEEE 802.11 standards, marketed under the Wi-Fi brand name.
WWAN	Wireless Wide Area Network refers to cellular airlink technologies as noted in Section Error! Reference source not found.

Appendix E Wi-Fi-LTE Emulator Test Equipment Notes when Testing EUTs that Support LTE Band 40 or 41 (Informative)

This is an informative appendix. The information in this appendix is to inform test labs that care should be used with test equipment when performing tests with EUTs that support LTE Band 40 or 41. With an incorrect test setup, results may be incorrect because of test equipment desense. Proper RF isolation is required between the cellular and Wi-Fi emulators. The test diagrams shown in this appendix are examples and variations of the test setup may differ or may not be required for each test lab.

Proper Wi-Fi and LTE emulator test equipment setup is required for Wi-Fi or cellular desense measurements for EUTs that support LTE Bands 40 or 41. LTE Bands 40 and 41 are next to the 2.4 GHz Wi-Fi band with little or no guard bands (see [Figure E-1](#) and [Figure E-2](#)). There is the possibility that the Wi-Fi or LTE emulator would be unable to attach to the EUT when performing these measurements due to test equipment immunity issues. The test lab shall insure they are measuring the over the air EUT Wi-Fi or cellular desense and not Wi-Fi or LTE emulator test equipment immunity.

FIGURE E- 3 LTE BAND 40 AND WI-FI 2.4 GHZ FREQUENCY DIAGRAM

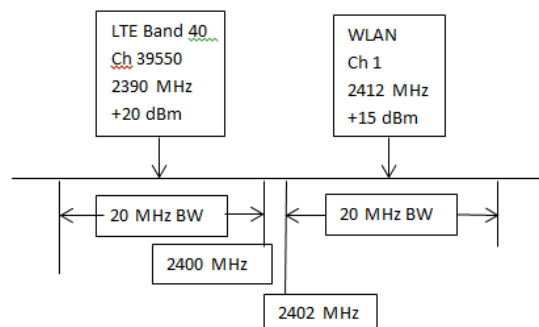
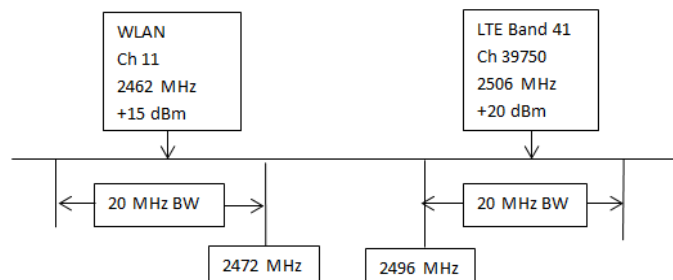

FIGURE E- 4 LTE BAND 41 AND WI-FI 2.4 GHZ FREQUENCY DIAGRAM



The test lab can verify Wi-Fi emulator test equipment immunity with the example test equipment diagram in the [Figure E-3](#). RF cavity tuned notch and/or bandpass filters are used to ensure the EUT is not desensed by the LTE device and for the LTE device to stay attached to the LTE emulator due to interference from the Wi-Fi. Attenuators can be used to simulate expected RF levels present at the Wi-Fi emulator while performing Wi-Fi EUT over the air desense measurements. Perform

sensitivity measurements with the EUT only (without LTE Band 40) and note results. Then attach LTE Band 40 EUT to the LTE emulator (at maximum output power). With the LTE Band 40 EUT attached, re-measure the Wi-Fi EUT. If the Wi-Fi sensitivity measurements are the same and Wi-Fi/LTE EUTs remain attached, the Wi-Fi emulator is immune to the adjacent channel interference. LTE base station emulator test equipment immunity can be verified by exchanging the positions of the emulators, RF filters and EUTs in the diagram.

FIGURE E- 5 Wi-Fi EMULATOR TEST EQUIPMENT VERIFICATION TEST SETUP (TO TEST THE LTE BASE STATION

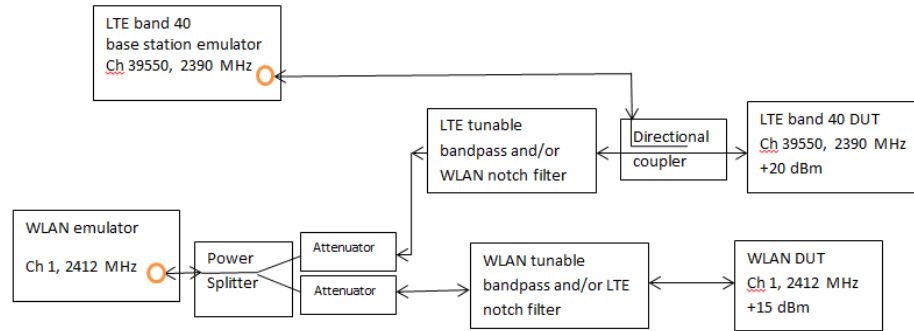

If the Wi-Fi or LTE emulator does show immunity problems, Figure E- 6 diagram shows an example on how to eliminate these problems (use RF filters as needed). If the lab is using an RF compression amplifier for the LTE input emulator, the RF filter must be installed after the output of the amplifier. If the device can stay attached to the LTE emulator, no RF filter is required. If the lab is using an RF preamplifier for the Wi-Fi emulator input, the RF filter should be connected to the input of the preamplifier. Care should be used when tuning the RF filters. If a Wi-Fi bandpass RF filter is used, be sure to add its loss into the system path loss and remove the filters when performing Wi-Fi TRP or TIS measurements.

FIGURE E- 7 EXAMPLE TEST SYSTEM DIAGRAM (ONLY FOR Wi-Fi DESENSE OR LTE CELLULAR DESENSE TESTS, IF THE EUT SUPPORTS LTE BAND 40)

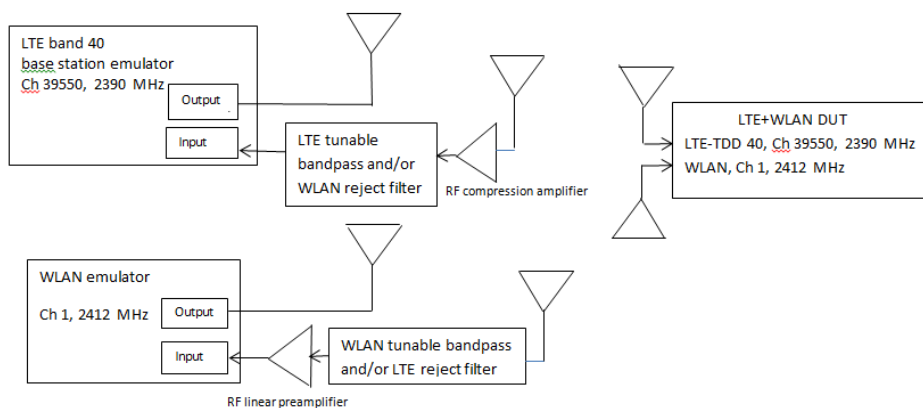

Appendix F Table of Wi-Fi Radio channels interfered by Cellular Radio Harmonics

The cellular radio configuration will be set according to the Call Setup Reference, in the table below, except for those parameters specifically defined within the table.

Test Plan Version 2.1.2

RAT	GSM 850		E-GSM 900		DCS 1800		GSM 1900		CDMA 800 Cellular BC0		CDMA 2100/1700 AWS-1 BC 15		CDMA 1800 BC 4		CDMA 1900 PCS BC1		CDMA 2000 BC6																																																																																																																																																																																																																																																																																																										
Region	North America, South America, Asia		South America, EU, Asia, Australia, Africa		South America, EU, Asia, Australia, Africa		North America, South America		North America, Asia		North America		Asia		North America, Asia		Asia																																																																																																																																																																																																																																																																																																										
Suggested alternate name																																																																																																																																																																																																																																																																																																																											
Call setup defined in reference document	CTIA Test Plan [1] Section 5.4		CTIA Test Plan [1] Appendix M		CTIA Test Plan [1] Appendix M		CTIA Test Plan [1] Section 5.4		CTIA Test Plan [1] Section 5.2		CTIA Test Plan [1] Section 5.2		CTIA Test Plan [1] Section 5.2		CTIA Test Plan [1] Section 5.2		CTIA Test Plan [1] Section 5.2																																																																																																																																																																																																																																																																																																										
Special setup																																																																																																																																																																																																																																																																																																																											
Band Edges																																																																																																																																																																																																																																																																																																																											
Uplink Freq		824.2	848.8	880.2	914.8	1710.2	1784.8	1850.2	1909.8	824.7	848.31	1711.25	1753.75	1751.25	1778.75	1851.25	1908.75	1920	1980																																																																																																																																																																																																																																																																																																								
Downlink Freq		869.2	893.8	925.2	959.8	1805.2	1879.8	1930.2	1989.8	869.7	881.52	2111.25	2153.75	1841.25	1868.75	1931.25	1988.75	2110	2170																																																																																																																																																																																																																																																																																																								
Desensitization of Wi-Fi Rx by Cellular Tx Uplink																																																																																																																																																																																																																																																																																																																											
<table border="1" style="width: 100%; border-collapse: collapse;"> <thead> <tr> <th>Chan</th> <th>Freq</th> <th>Chan</th> <th>Freq</th> <th>Chan</th> <th>Freq</th> <th>Chan</th> <th>Freq</th> <th>Chan</th> <th>Freq</th> <th>Chan</th> <th>Freq</th> <th>Chan</th> <th>Freq</th> <th>Chan</th> <th>Freq</th> <th>Chan</th> <th>Freq</th> <th>Chan</th> <th>Freq</th> </tr> </thead> <tbody> <tr> <td>1</td> <td>2412</td> <td></td> <td></td> <td></td> <td></td> <td></td> <td></td> <td></td> <td></td> <td></td> <td></td> <td></td> <td></td> <td></td> <td></td> <td></td> <td></td> <td></td> <td></td> </tr> <tr> <td>2</td> <td>2417</td> <td></td> <td></td> <td></td> <td></td> <td></td> <td></td> <td></td> <td></td> <td></td> <td></td> <td></td> <td></td> <td></td> <td></td> <td></td> <td></td> <td></td> <td></td> </tr> <tr> <td>3</td> <td>2422</td> <td></td> <td></td> <td colspan="4" rowspan="3" style="text-align: center; vertical-align: middle;">Black boxes indicate Wi-Fi Rx vulnerability due to Cellular uplink Tx</td> <td></td> <td></td> <td></td> <td></td> <td></td> <td></td> <td></td> <td></td> <td></td> <td></td> <td></td> <td></td> </tr> <tr> <td>4</td> <td>2427</td> <td></td> <td></td> <td></td> <td></td> <td></td> <td></td> <td></td> <td></td> <td></td> <td></td> <td></td> <td></td> <td></td> <td></td> <td></td> <td></td> </tr> <tr> <td>5</td> <td>2432</td> <td></td> <td></td> <td></td> <td></td> <td></td> <td></td> <td></td> <td></td> <td></td> <td></td> <td></td> <td></td> <td></td> <td></td> <td></td> <td></td> </tr> <tr> <td>6</td> <td>2437</td> <td></td> <td></td> <td></td> <td></td> <td></td> <td></td> <td></td> <td></td> <td></td> <td></td> <td></td> <td></td> <td></td> <td></td> <td></td> <td></td> <td></td> <td></td> </tr> <tr> <td>7</td> <td>2442</td> <td></td> <td></td> <td></td> <td></td> <td></td> <td></td> <td></td> <td></td> <td></td> <td></td> <td></td> <td></td> <td></td> <td></td> <td></td> <td></td> <td></td> <td></td> </tr> <tr> <td>8</td> <td>2447</td> <td></td> <td></td> <td></td> <td></td> <td></td> <td></td> <td></td> <td></td> <td></td> <td></td> <td></td> <td></td> <td></td> <td></td> <td></td> <td></td> <td></td> <td></td> </tr> <tr> <td>9</td> <td>2452</td> <td></td> <td></td> <td></td> <td></td> <td></td> <td></td> <td></td> <td></td> <td></td> <td></td> <td></td> <td></td> <td></td> <td></td> <td></td> <td></td> <td></td> <td></td> </tr> <tr> <td>10</td> <td>2457</td> <td></td> <td></td> <td></td> <td></td> <td></td> <td></td> <td></td> <td></td> <td></td> <td></td> <td></td> <td></td> <td></td> <td></td> <td></td> <td></td> <td></td> <td></td> </tr> <tr> <td>11</td> <td>2462</td> <td>128</td> <td>824.2</td> <td></td> <td></td> <td></td> <td></td> <td></td> <td></td> <td>1013</td> <td>824.7</td> <td></td> <td></td> <td></td> <td></td> <td></td> <td></td> <td></td> <td></td> </tr> <tr> <td>12</td> <td>2467</td> <td></td> <td></td> <td></td> <td></td> <td></td> <td></td> <td></td> <td></td> <td></td> <td></td> <td></td> <td></td> <td></td> <td></td> <td></td> <td></td> <td></td> <td></td> </tr> <tr> <td>13</td> <td>2472</td> <td>128</td> <td>824.2</td> <td></td> <td></td> <td></td> <td></td> <td></td> <td></td> <td>1013</td> <td>824.7</td> <td></td> <td></td> <td></td> <td></td> <td></td> <td></td> <td></td> <td></td> </tr> <tr> <td>14</td> <td>2484</td> <td>147</td> <td>828</td> <td></td> <td></td> <td></td> <td></td> <td></td> <td></td> <td>77</td> <td>827.3</td> <td></td> <td></td> <td></td> <td></td> <td></td> <td></td> <td></td> <td></td> </tr> </tbody> </table>																				Chan	Freq	Chan	Freq	Chan	Freq	Chan	Freq	Chan	Freq	Chan	Freq	Chan	Freq	Chan	Freq	Chan	Freq	Chan	Freq	1	2412																			2	2417																			3	2422			Black boxes indicate Wi-Fi Rx vulnerability due to Cellular uplink Tx																4	2427																	5	2432																	6	2437																			7	2442																			8	2447																			9	2452																			10	2457																			11	2462	128	824.2							1013	824.7									12	2467																			13	2472	128	824.2							1013	824.7									14	2484	147	828							77	827.3								
Chan	Freq	Chan	Freq	Chan	Freq	Chan	Freq	Chan	Freq	Chan	Freq	Chan	Freq	Chan	Freq	Chan	Freq	Chan	Freq																																																																																																																																																																																																																																																																																																								
1	2412																																																																																																																																																																																																																																																																																																																										
2	2417																																																																																																																																																																																																																																																																																																																										
3	2422			Black boxes indicate Wi-Fi Rx vulnerability due to Cellular uplink Tx																																																																																																																																																																																																																																																																																																																							
4	2427																																																																																																																																																																																																																																																																																																																										
5	2432																																																																																																																																																																																																																																																																																																																										
6	2437																																																																																																																																																																																																																																																																																																																										
7	2442																																																																																																																																																																																																																																																																																																																										
8	2447																																																																																																																																																																																																																																																																																																																										
9	2452																																																																																																																																																																																																																																																																																																																										
10	2457																																																																																																																																																																																																																																																																																																																										
11	2462	128	824.2							1013	824.7																																																																																																																																																																																																																																																																																																																
12	2467																																																																																																																																																																																																																																																																																																																										
13	2472	128	824.2							1013	824.7																																																																																																																																																																																																																																																																																																																
14	2484	147	828							77	827.3																																																																																																																																																																																																																																																																																																																



802.11a Band	7	5035																
	8	5040																
802.11a U-NII Low Band	36	5180																
	40	5200																
	44	5220				661	1740					600	1740					
	48	5240																
802.11a U-NII Mid Band	52	5260																
	56	5280																
	60	5300				794	1766.6						334	1766.7				
	64	5320																
802.11a ETSI Band	100	5500																
	112	5560																
	116	5580																
	120	5600																
	124	5620						628	1873.4					468	1873.4			
	128	5640																
	132	5660																
	136	5680																
802.11a U-NII Upper Band	149	5745																
	153	5765																
	157	5785															167	1928.4
	161	5805																
802.11a USA band	165	5825																



RAT	WCDMA 3GPP Band I	WCDMA 1900 3GPP Band II	WCDMA 3GPP Band III	WCDMA 2100/1700 3GPP Band IV	WCDMA 850 3GPP Band V	WCDMA 3GPP Band VIII	LTE Band 1	LTE Band 2	LTE Band 3
Region	EU, Asia, Middle East, Africa, Australia	North America, South America, Asia	EU, Asia	North America, South America	North America, South America, Asia, Australia	EU, Asia, South America, Middle East, Australia, Africa	Japan, EU, Middle East, Africa, Australia	North America, South America	Asia, EU, Middle East, Africa, Australia
Suggested alternate name									
Call setup defined in reference document	CTIA Test Plan [1] Appendix M	CTIA Test Plan [1] Section 5.7	CTIA Test Plan [1] Appendix M	CTIA Test Plan [1] Section 5.7	CTIA Test Plan [1] Section 5.7	CTIA Test Plan [1] Appendix M	CTIA Test Plan [1] Appendix M	CTIA Test Plan [1] Section 5.8	CTIA Test Plan [1] Appendix M
Special setup							10 MHz Tx BW, 12 RBs	10 MHz Tx BW, 12 RBs	10 MHz Tx BW, 12 RBs

Band Edges																			
Uplink Freq	1920	1980	1852.4	1907.6	1710	1785	1712.4	1752.6	826.4	846.6	882.4	912.6	1925	1975	1855	1905	1715	1780	
Downlink Freq	2112.4	2167.1	1932.4	1987.6	2112.4	2152.6	2112.4	2152.6	871.4	881.6	927.4	957.6	2115	2165	1935	1985	1810	1875	

Desensitization of Wi-Fi Rx by Cellular Tx Uplink

	Chan	Freq	Chan	Freq	Chan	Freq	Chan	Freq	Chan	Freq	Chan	Freq	Chan	Freq	Chan	Freq	Chan	Freq	Chan	Freq
802.11b/g/n	1	2412																		
	2	2417																		
	3	2422																		
	4	2427																		
	5	2432																		
	6	2437																		
	7	2442																		
	8	2447																		
	9	2452																		
	10	2457																		
	11	2462								4357	826.4									
	12	2467																		
	13	2472								4357	826.4									
	14	2484								4365	828									



802.11a Band	7	5035																	
	8	5040																	
802.11a U-NII Low Band	36	5180																	
	40	5200																	
	44	5220				1300	1740	1675	1740									19500	1740
	48	5240																	
802.11a U-NII Mid Band	52	5260																	
	56	5280																	
	60	5300				1433	1766.6											19766	1766.6
	64	5320																	
802.11a ETSI Band	100	5500																	
	112	5560																	
	116	5580																	
	120	5600																	
	124	5620			9767	1873.4												18832	1873.2
	128	5640																	
	132	5660																	
	136	5680																	
140	5700																		
802.11a U-NII Upper Band	149	5745																	
	153	5765																	
	157	5785	10592	1928.4														18082	1928.2
	161	5805																	
802.11a USA band	165	5825																	



RAT	LTE Band 4	LTE Band 5	LTE Band 7	LTE Band 8	LTE Band 12	LTE Band 13	LTE Band 14	LTE Band 17	LTE Band 20	LTE Band 25
						Note: only one channel, 23230	Note: only one channel, 23330			
Region	North America, South America	North America, South America, Asia, Australia	North America, EU, Asia, Middle East, Africa,	EU, Asia	North America	North America	North America	North America	EU, Middle East, Africa	North America
Suggested alternate name		E-UTRA Band 5							E-UTRA Band 20	
Call setup defined in reference document	CTIA Test Plan [1] Section 5.8	CTIA Test Plan [1] Section 5.8	CTIA Test Plan [1] Section 5.8	CTIA Test Plan [1] Appendix M	CTIA Test Plan [1] Section 5.8	CTIA Test Plan [1] Section 5.8	CTIA Test Plan [1] Section 5.8	CTIA Test Plan [1] Section 5.8	CTIA Test Plan [1] Appendix M	CTIA Test Plan [1] Section 5.8
Special setup	10 MHz Tx BW, 12 RBs	10 MHz Tx BW, 12 RBs	20 MHz Tx BW, 18 RBs	10 MHz Tx BW, 12 RBs	5 MHz Tx BW, 8 RBs	10 MHz Tx BW, 12 RBs	10 MHz Tx BW, 12 RBs	10 MHz Tx BW, 12 RBs	10 MHz Tx BW, 12 RBs	5 MHz Tx BW, 8 RBs

Band Edges

Uplink Freq	1715	1750	829	844	2505	2565	895	920	704	711	782	782	793	793	709	711	837	857	1852.5	1912.5
Downlink Freq	2115	2150	874	889	2625	2685	930	955	734	741	751	751	763	763	739	741	796	816	1932.5	1992.5

Desensitization of Wi-Fi Rx by Cellular Tx Uplink

	Chan	Freq	Chan	Freq	Chan	Freq	Chan	Freq	Chan	Freq	Chan	Freq	Chan	Freq	Chan	Freq	Chan	Freq	Chan	Freq	Chan	Freq		
	802.11b/g/n	1	2412																					
2		2417																						
3		2422																						
4		2427			Black boxes indicate Wi-Fi Rx vulnerability due to Cellular uplink Tx																			
5		2432																						
6		2437																						
7		2442																						
8		2447																						
9		2452																						
10		2457																						
11		2462			20450	825.6																		
12		2467																						
13		2472			20450	825.6																		
14		2484			20450	825.6																		



802.11a Band	7	5035																		
	8	5040																		
802.11a U-NII Low Band	36	5180																		
	40	5200																		
	44	5220	20250	1740																
	48	5240																		
802.11a U-NII Mid Band	52	5260																		
	56	5280																		
	60	5300																		
	64	5320																		
802.11a ETSI Band	100	5500																		
	112	5560																		
	116	5580																		
	120	5600																		
	124	5620																		
	128	5640																		
	132	5660																		
	136	5680																		
	140	5700																		
802.11a U-NII Upper Band	149	5745																		
	153	5765																		
	157	5785																		
	161	5805																		
802.11a USA band	165	5825																		



RAT	LTE Band 38		LTE Band 39		LTE Band 40		LTE Band 41		TD-SCDMA Band A		TD-SCDMA Band F1		TD-SCDMA Band F2			
Region	EU, Asia, Middle East		Asia		Asia, Australia, Middle East, Africa		North America, Asia		China		China		China			
Suggested alternate name																
Call setup defined in reference document	CWG Appendix C		CWG Appendix C		CWG Appendix C		CTIA Test Plan [1] Section 5.8		CWG Appendix C		CWG Appendix C		CWG Appendix C			
Special setup	20 MHz Tx BW, 18 RBs		20 MHz Tx BW, 18 RBs		20 MHz Tx BW, 18 RBs		20 MHz Tx BW, 18 RBs									
Band Edges																
Uplink Freq	2570	2620	1880	1920	2300	2400	2496	2689.9	2010	2025	1880	1890	1890	1898.4		
Downlink Freq	2570	2620	1880	1920	2300	2400	2496	2689.9	2010	2025	1880	1890	1890	1898.4		
Desensitization of Wi-Fi Rx by Cellular Tx Uplink																
	Chan	Freq	Chan	Freq	Chan	Freq	Chan	Freq	Chan	Freq	Chan	Freq	Chan	Freq	Chan	Freq
802.11b/g/n	1	2412														
	2	2417														
	3	2422														
	4	2427														
	5	2432														
	6	2437														
	7	2442														
	8	2447														
	9	2452														
	10	2457														
	11	2462														
	12	2467														
	13	2472														
	14	2484														



802.11a Band	7	5035															
	8	5040															
802.11a U-NII Low Band	36	5180															
	40	5200															
	44	5220	38150	2610					38150	2610							
	48	5240															
802.11a U-NII Mid Band	52	5260															
	56	5280															
	60	5300							41190	2650							
	64	5320															
802.11a ETSI Band	100	5500															
	112	5560															
	116	5580															
	120	5600															
	124	5620															
	128	5640										9404	1880.4				
	132	5660										9436	1887.2				
	136	5680												9468	1893.6		
	140	5700			19100	1900								9492	1898.4		
802.11a U-NII Upper Band	149	5745			36150	1915											
	153	5765															
	157	5785															
	161	5805															
802.11a USA band	165	5825															



Appendix G Change History

Version	Date	Comments
1.0	08-Aug-2006	Document Approved
1.1	20-Aug-2007	<ul style="list-style-type: none"> • Updated Purpose and References sections • Clarified text and added footnote in Radiated RF Tests nomenclature section • Clarified text in Minimum Measurement Distance section • Clarified testing conditions for cellular inactive state • Corrected step reference in step 14 of Receive Sensitivity Measurement. Removed repeated text. • Removed reference to CTIA website for traffic generator software download • Corrected step 1 and clarified language in step 9 regarding antenna connection in WLAN Access Point Testing Methodology section • Removed requirement for OFMD transmit mask test on Mobile Stations and Access Points • Updated WLAN Test Set Estimated Signal Level tables • Added Sample Summation test report table • Corrected title on Test 5.2.2. and 6.2.2 test report table • Added text to clarify that Wi-Fi desense testing is done in free-space only • Clarified that cellular desense testing is done in free-space only, and to perform reference measurements if not previously done • Removed references to specific test equipment from document
1.2	26-June-2008	<ul style="list-style-type: none"> • 5 GHz TRP, TIS, & Reference Measurement frequency changes – Sections 5.1.1.2, 5.1.2.2, 5.2.1.2, 5.2.2.2, Table 5.2 5, 6.1.1.2, 6.1.2.2, 6.2.1.2, 6.2.2.2, Table B2 , Table B3, Table B4, Table B5, Table B6, Table B7, New Appendix D • Other sections changed: Table B1 - CID Added, section 1.4 - CTIA Reference updated, Table A1 Channel change UTRA FDD Band I - IV, 4120/824.0 changed to 4132/826.4, Table B3 Reference changed from (2) to (1), Table 5.1.1 and table 6.1.1 - removed "Check Tx Mask" from comments column
1.3	01-June-2009	<ul style="list-style-type: none"> • Added footnote to Section 2.1, 2nd sentence. • Added text to Section 4.1, 2nd sentence. • Added CTIA Request # to Appendix B table. • Added Appendix E Device Capabilities Testing Matrix
2.0	27-Feb-2015	<ul style="list-style-type: none"> • Added 802.11n • Added LTE and TD-SCDMA protocols

Version	Date	Comments
		<ul style="list-style-type: none"> • Updated cellular and Wi-Fi desense sections • Updated Appendix B Device Capabilities Test Matrix, removed right head and added right and left hand phantoms • Added Appendix C – Radio Access Technologies that require testing, but are not covered in the CTIA OTA Test Plan [1]. • Added Appendix D - Notebook and Tablet PC Requirements • Added Appendix E - WLAN-LTE emulator test equipment notes when testing EUTs that support LTE band 40 or 41 (Informative) • Added Appendix F - Table of Wi-Fi Radio channels interfered by cellular radio harmonics • Revised Wi-Fi test procedure Sections 3.1, 4.1, 4.2 & 4.3 • Updated the Acknowledgements list • Updated Section 4.1.3 Measurement Frequencies for Radiated tests • Updated Table 2 parameters • Split Table 3 to Table 3 and Table 4 for Tx and Rx and also changed Rx parameters • Updated Section 2.1 • Replaced WLAN with Wi-Fi thought out the document as appropriate • Revised Section 2.2 to specify PING as the primary mode for packet generation • Revised Tables 17 and 18 to replace DER with Pass/Fail info on Intermediate Channels • Updated title and introduction text of Appendix A • Updated Table 12 consistent with the test case requirements of Section 4.6 and 4.17 • Updated Appendix F to include Wi-Fi desensitization matrix • Reference Polarization columns added to all Appendix A tables that include Reference Position information
2.0.1	01-July-2015	<ul style="list-style-type: none"> • Modified document reference in 5th paragraph of Section 2.2. • Updated RAT Channel Number and RAT Uplink Frequency columns in Table 4-5 • Updated channel for UNII Low, Middle and Upper Bands in Table A-5 and Table A-6. • Deleted first sentence of Appendix A.3. • Added text to section 1.6.2. • Removed stray text in Table A-2. • Fixed cross-references

Version	Date	Comments
2.0.2	07-Oct-2015	<ul style="list-style-type: none"> • “Draft 1” removed from the footnote • Publication and footnote dates updated based on CTIA format • Tables A-7 and A-8 modified to include a field for Lab comments on maximum EIS • Modified Section 2.2 to provide explicit guidelines for PING method for 802.11n • Applied other purely editorial changes to the titles in Appendices sections and tables • Removed “(WI-FI U-NII MIDDLE BAND)” from the titles and references to Channel 60 in Tables A-10 and A-12 • Requirement for usage of Hand Phantoms is clarified in Appendix B
2.0.3	30-Sept-2016	<ul style="list-style-type: none"> • Modified Appendix B text regarding usage of Hand Phantoms. • Added reference table for Wi-Fi radio desensitization by closest cellular uplink frequency in Section 4.2.4. Examples corrected. • Updated CTIA logo and Wi-Fi Alliance logo. • Applied purely editorial correction throughout document. • Applied changes to Section 2.1 regarding adaptive power control and regulatory domain (country code) setting. • Applied further modifications to Section 4.2.4. • Updated Table numbering in Section 4. • Table B-1 modified to cover testing applicability for devices with and without WWAN simultaneous operation capability. • Applied purely editorial changes to Sections 4.2.4 and 4.2.5. • Clarification made in Section 3.1.5 regarding traffic generation. • Table B-1 was reformatted without change in the content. • Corrected Item 44.6 LTE Band 38 Channel Number and some references in Table 4-6. • Editorial changes applied throughout document. • References in Section 4.1 was updated/corrected. • Applied further corrections to Table 4-6. • Updated Appendix F. • Updated Acknowledgement table.

Version	Date	Comments
2.1.0	January 2019	<ul style="list-style-type: none"> • Applied changes throughout document to cover 802.11ac • Applied changes throughout document to make CTIA OTA Test Plan as the basis • Updated reference to latest release of IEEE 802.11 (IEEE Std. 802.11-2016) • Updated Section 4.1.4 & 4.3.2 as related to support for multiple Wi-Fi TX antennas • Updated Section 4.1.5 as related to support for Antenna Switched RX Diversity for Wi-Fi • Updated Section 4.2.3 as related to support for multiple cellular TX antennas • Coverage for TD-SCDMA was added to Section 4.2.3, 4.3.4 • Corrected Table 4.2-3 for CDMA 1800 BC 15 • Reference to OTA Test Plan Appendix O.3, O.4 and O.5 added to Section 4.3.3, 4.3.4 and Appendix D to enable support for reduced legacy RAT testing for TIS and/or intermediate channel testing in free-space • Section 4.3.4 title and content updated to properly cover Test Procedure for RATs without Free-Space Limits • A new sub-band column added to Table A- 12; rows updated to make the report template complete • Appendix guidelines related to Notebooks, Tablets, Convertible PCs and Hybrid PCs testing in their primary mechanical mode was added to Appendix D
2.1.2	December 2020	<ul style="list-style-type: none"> • Updated formatting, logos, and copyright • Added use instructions • Updated CTIA Certification URL