



Test Plan for Wireless Device Over-the-Air Performance

Method of Measurement for Radiated RF Power and Receiver Performance

Version 3.9.2

April 2021

© 2001-2021 CTIA Certification. All Rights Reserved.

Any reproduction, modification, alteration, creation of a derivative work, or transmission of all or any part of this publication ("Test Plan"), in any form, by any means, whether electronic or mechanical, including photocopying, recording, or via any information storage and retrieval system, without the prior written permission of CTIA Certification, is unauthorized and strictly prohibited by federal copyright law. This Test Plan is solely for use within the CTIA Certification Program. Any other use of this Test Plan is strictly prohibited unless authorized by CTIA Certification or its assigns in writing.

Use Instructions

All testing to this test plan must be conducted in a CTIA Certification Authorized Test Lab. This may be accomplished in one of two ways:

1. As part of a PTCRB certification request submitted at <https://www.ptcrb.com/>
2. By submitting an OTA Test Plan use request at <https://certify.ctiacertification.org/>

CTIA Certification Program
1400 16th Street N.W., Suite 600
Washington, DC 20036

programs@ctiacertification.org
1.202.785.0081

<https://ctiacertification.org/test-plans/>

Acknowledgements: This test plan was created by the wireless industry with input from the following companies and their representatives:

Company, Representative	Company, Representative
7 Layers: Clive Bax, Dominik Mente	Microsoft: Kevin Li
Apple: Diego Hernandez, Kevin Z. Navares, Harneet Oberoi, Taeho Park, Sravya Pendyala, Indranil Sen, Wisuit Sinsathitchai	Motorola Mobility: David Bush, Eric Krenz, Philip Makotyn, Edwin Mendivil, Paul Moller, Andrew Pavacic, Paul Peterson, Jim Philips, Roger Scheer, Carl Seaberg
AT&T: Ron Borsato, Jan Chaffee, Dave Chapman, Virgilio Corral, Steve Harbin, Carl Martin, Scott Prather	MultiTech Systems: Terry Boe, Tom Hofstede
Blackberry: Perry Jarmuszewski, Xin Jin, Yihong Qi, Qingmai Zhou	MVG: John Estrada, Sebastien Gaymay, Nicolas Gross, Per Iversen, Kim Rutkowski, Alessandro Scannavini
Bureau Veritas ADT: Clive Bax, Eddie Parsons, Fred Yang	NextNav, LLC: Waldemar Kunysz, Subbu Meiyappan, Cristina Seibert, Bill Shvodian
CETECOM, Inc.: Lothar Schmidt, Thomas Tam	Nokia Corp.: Bob Alexander, Randy Leenerts, Kevin Li, Pertti Makikyro, Miia Nurkkala, Hugh Shapter, Jesse Torres
CTTL: Zheng Liu	Paul Moller Consulting: Paul Moller
Dell: Justin Harbour, Keith Hendrickson, Elvis Yen	PCTEST Engineering Laboratory, LLC: Ron Borsato, Baron Chan, Luis Magana, Matt Smith, Andrea Zaworski
Dish Network: Jussi Kuusisto	Qualcomm, Inc.: Greg Breit, Pat Connor, Thom Erickson, Dennis Feenaghty, Paul Guckian, Sri Kasturi, Allen Tran
ETS-Lindgren: Michael Foegelle, Edwin Mendivil	Rohde & Schwarz: Jose M. Fortes, Christoph Gagern, Thorsten Hertel
Google, LLC: Karthikbabu Adappa Laxmi, Kevin Li	Samsung: Ingmar Dippe, Chirag Panchal
Hewlett-Packard: Jim Cottrell, Isaac Lagnado, Glenn Meyer, Tim Neill	Schmid & Partner Engineering AG: Parisa Fallahi, Erdem Ofli, Fereshteh Rouholahnejad
The Howland Company: Jamie Huff, Carl Sirls	Schmidt Consulting: Lothar Schmidt
IndexSAR Ltd.: David Riley	SGS: Jason Bartosch, Chris Hiesberger, Peter Liao
Intel: Anatoliy Ioffe, Hassan Yaghoobi	Siemens ICM, LLC: Milton de Leon, Peter Nevermann
Intertek: Kevin Colaco, Bill Henning	Sony Mobile Communications, Inc.: Ken Bednasz, Pierre Chery, George Daniel, Gerry Hayes, Matt Isley, Jim Sponsler, Scott Vance
IT'IS Foundation: Niels Kuster	Spirent Communications: Hakan Alparsan, Ron Borsato, William Chan
Keysight Technologies: Thorsten Hertel	Sporton: Lorien Chang, Elvis Yen
Kyocera: Doug Dunn	T-Mobile: Adeel Ahmad, Uday Dodla, John Fessler, Michael Hart, Chris Hiesberger, David Holmes, Drew Liszewski, Fermin Romero, Alex Tkatch
Lenovo: Jim Salembier	UL Verification Services: Mike Heckrotte
MCL Technology Limited: Phil Chadwick, Camelia Gabriel	Verizon Wireless: Ron Borsato, Lou LaMedica, Wayne Wilson, Andrew Youtz

Table of Contents

	List of Figures	17
	List of Tables	21
Section 1	Introduction	
1.1	Purpose	27
1.2	Scope	27
1.3	Applicable Documents	27
1.4	Test Overview	30
1.5	Equipment Under Test (EUT) and Accessories—The Wireless Device	30
1.6	Wireless Device Documentation	31
Section 2	Scope of Measurements	
2.1	Equipment Under Test (EUT) Measurements—Transmitter	33
2.2	Equipment Under Test (EUT) Measurements—Receiver	34
2.3	Equipment Under Test (EUT) Measurements—General	34
2.4	Conical Cut Test Method	35
2.5	Great Circle Test Method	36
2.6	Theta Dependent Phi Step Size Optimization	38
Section 3	Test Site Characteristics and Quiet Zone Accuracy	
3.1	Minimum Measurement Distance	39
3.2	Equipment Required	42
3.3	Test Frequencies	43
3.4	Terminology and Coordinate Systems	43
3.5	Basic Measurement Procedure	46
3.5.1	Probe Antenna Symmetry Test	46
3.5.2	Phi-Axis Ripple Test	47
3.5.3	Theta-Axis Ripple Test	49
3.5.4	Allowances and Adjustments	50
3.6	Additional Ripple Test Requirements for Notebook-Sized Test Volumes	52
3.6.1	Probe Antenna Symmetry Test	53
3.6.2	Extensions to Phi-Axis Ripple Test	53
3.6.3	Extension to Theta-Axis Ripple Test	54
3.6.4	Additions to Allowances and Adjustments	55
3.7	Applying the Ripple Test Procedure to Specific Systems	56
3.8	Analysis	58
Section 4	Range Reference Requirements	
4.1	Theoretical Background	60
4.2	Equipment Required	62
4.3	Test Frequencies	63
4.4	Test Procedure	66
4.4.1	Measurement Step 1: Source Reference Test (Cable Calibration)	66

4.4.2	Measurement Step 2: Range Reference Test	67
4.4.3	Calculating the Range Reference Path Loss	69
4.5	Range Reference Measurement Data File	72
4.6	Alternate Scenarios	73
4.6.1	TRP Reference	73
4.6.2	TIS Reference	74
4.6.3	Ripple Based Calibration	74
4.7	Wideband Channels	74
Section 5	Test Procedure—Radiated Power	
5.1	AMPS	76
5.2	CDMA	77
5.2.1	Test Procedure	77
5.2.2	Criteria	79
5.3	TDMA	83
5.4	GSM	83
5.4.1	Test Procedure	83
5.4.2	Criteria	84
5.5	GPRS	86
5.5.1	Test Procedure	86
5.5.2	Criteria	87
5.6	EGPRS	88
5.6.1	Test Procedure	88
5.6.2	Criteria	89
5.7	UMTS (WCDMA)	91
5.7.1	Test Procedure	91
5.7.2	Criteria	92
5.8	LTE	94
5.8.1	Test Procedure	94
5.8.2	Criteria	96
5.9	CDMA 1xEV-DO DATA	99
5.9.1	Test Procedure	99
5.9.2	Criteria	101
5.10	CDMA 1xRTT DATA	104
5.10.1	Test Procedure	104
5.10.2	Criteria	105
5.11	Alternate Test Procedure for TRP	109
5.11.1	Single Point Offset Test (SPOT)	109
5.11.2	Multi-point Offset Test	110
5.11.3	Spiral Scan Procedure for TRP	110
5.11.4	TRP Measurement of Low Transmit Duty-Cycle Devices	111
5.12	LTE Two Downlink Carrier Aggregation (Single Uplink Carrier)	112
5.12.1	Test Procedure	112
5.12.2	Criteria	119
5.13	LTE Three Downlink Carrier Aggregation (Single Uplink Carrier)	126
5.13.1	Test Procedure	126

5.13.2	Criteria	142
5.14	OTA Testing of Devices Containing Multiple TX Antennas	153
5.14.1	Devices where the Active TX Antenna Could Change during the Execution of the Test Cases	153
5.14.2	Devices where the Active TX Antenna Does Not Switch during the Execution of the Test Cases	154
5.15	LTE Category M1	154
5.15.1	Test Procedure	154
5.15.2	Criteria	156
5.16	LTE Category NB1 (NB-IoT)	157
5.16.1	Test Procedure	157
5.16.2	Criteria	159
5.17	New Radio (NR) Frequency Range 1 (FR1) (Informative)	161
5.17.1	Test Procedure	161
5.17.2	Criteria	162
Section 6	Test Procedure—Receiver Performance	
6.1	AMPS	164
6.2	CDMA	164
6.2.1	Test Procedure	164
6.2.2	Criteria	168
6.3	TDMA	169
6.4	GSM	169
6.4.1	Test Procedure	169
6.4.2	Criteria	173
6.5	GPRS	174
6.5.1	Test Procedure	174
6.5.2	Criteria	178
6.6	EGPRS	179
6.6.1	Test Procedure	179
6.6.2	Criteria	183
6.7	UMTS (WCDMA)	184
6.7.1	Test Procedure	184
6.7.2	Criteria	187
6.8	LTE	188
6.8.1	Test Procedure	188
6.8.2	LTE Intermediate Channel Measurements	191
6.8.3	Criteria	194
6.9	CDMA 1xEV-DO DATA	196
6.9.1	Test Procedure	196
6.9.2	Criteria	200
6.10	CDMA 1xRTT DATA	201
6.10.1	Test Procedure	201
6.10.2	Criteria	204
6.11	CDMA with Receive Diversity	205
6.12	UMTS Two-Branch Receive Diversity	205

6.13	A-GNSS	205
6.13.1	Test Procedure	205
6.13.2	Radiated 3D C/N ₀ Pattern Measurement	206
6.13.2.1	General	206
6.13.2.2	A-GPS L1	207
6.13.2.3	A-GLONASS	207
6.13.3	Radiated A-GNSS Sensitivity Measurement	207
6.13.3.1	General	207
6.13.3.2	A-GPS L1	208
6.13.3.3	A-GLONASS	208
6.13.4	Radiated A-GNSS Intermediate Channel Degradation Measurement	209
6.13.4.1	General	209
6.13.4.2	A-GPS L1	211
6.13.4.3	A-GLONASS	211
6.13.5	Cellular Radio Mode Test Specifics	211
6.13.5.1	CDMA	211
6.13.5.2	UMTS	212
6.13.5.3	GSM	214
6.13.5.4	LTE	216
6.13.5.5	LTE Category M1	226
6.13.6	Criteria	231
6.14	FLO (Forward Link Only)	260
6.15	Alternate Test Procedure for TIS	260
6.15.1	Single Point Offset Test	260
6.15.2	Multi-point Offset Test	261
6.15.3	Alternate Test Procedure for GSM TIS Using Less Than Maximum TX Power	262
6.15.4	Alternate TIS Test Procedure based on Receive Signal Strength (RSS)	262
6.15.4.1	RSS Pattern Measurement	262
6.15.4.2	RSS Pattern Linearization	263
6.15.4.3	Sensitivity Search	264
6.15.4.4	RSS Data Format	264
6.15.4.5	Error Rate Data Format	266
6.15.4.6	Final TIS Calculation	267
6.15.5	TIS Measurement of Low Transmit Duty-Cycle Devices	268
6.16	LTE Two Downlink Carrier Aggregation	269
6.16.1	Test Procedure	269
6.16.2	Criteria	281
6.17	LTE Three Downlink Carrier Aggregation	295
6.17.1	Test Procedure	295
6.17.2	Criteria	316
6.18	MBS	352
6.18.1	Test Procedure	352
6.18.2	Radiated 3D RSS Pattern Measurement	353
6.18.2.1	General	353
6.18.3	Radiated MBS Sensitivity Measurement	354
6.18.3.1	General	354

	6.18.3.2	Single Band Optimization	354
6.18.4		Radiated MBS Intermediate Channel Degradation Measurement	355
	6.18.4.1	General	355
6.18.5		Cellular Radio Mode Test Specifics	357
	6.18.5.1	LTE	357
6.18.6		Criteria	358
6.19		Receiver Performance Testing of Devices with Antenna Switching	361
6.19.1		Devices Where the Receiver Could Connect to a Different RX Antenna During the Execution of the Test Cases	362
6.19.2		Devices Where the Receiver Does Not Switch to a Different Antenna During the Execution of the Test Cases	363
6.20		LTE Category M1	363
6.20.1		Test Procedure	363
6.20.2		Criteria	366
6.21		LTE LAA Downlink Carrier Aggregation	367
6.21.1		Test Procedure	367
6.21.2		Criteria	376
6.22		LTE Category NB1 (NB-IoT)	385
6.22.1		Test Procedure	385
6.22.2		Criteria	387
6.23		New Radio (NR) Frequency Range 1 (FR1) (Informative)	387
6.23.1		Test Procedure	388
6.23.2		NR FR1 Intermediate Channel Measurements	390
6.23.3		Criteria	390
Section 7		Measurement Uncertainty	
7.1		TRP Tests	392
7.1.1		EUT Measurement	393
7.1.2		Reference Measurement	395
7.1.3		Calculation of the Combined and Expanded Uncertainties for the Overall TRP Measurement	397
7.2		TIS Tests	397
7.2.1		EUT Measurement	397
7.2.2		Reference Measurement	399
7.2.3		Calculation of the Combined and Expanded Uncertainties for the Overall TIS Measurement	400
7.3		Alternate Test Procedures for TRP Measurements	400
7.3.1		Single/Multi-point Offset TRP Test	400
7.4		Alternate Test Procedures for TIS Measurements	402
7.4.1		Single/Multi-point Offset TIS Test Procedure	402
7.5		Criteria—Measurement Uncertainty	404
Appendix A		Test Set-up Configurations (Normative)	
A.1		Positioning Requirements and Coordinate Systems	405
A.1.1		Free-Space	405
A.1.2		Head Phantom Only	407

A.1.3	Hand Phantom Selection	410
A.1.4	Head and Hand Phantom (“Talk Mode”)	411
A.1.4.1	Mounting Monoblock EUT in Monoblock Hand Phantom for Talk Mode	414
A.1.4.2	Mounting Fold EUT in Fold Hand Phantom for Talk Mode	416
A.1.4.3	Mounting Wide EUT in PDA Hand Phantom for Talk Mode	418
A.1.4.4	Mounting a Wide EUT in the Wide Grip Hand Phantom for Talk Mode	420
A.1.5	Hand Phantom Only	422
A.1.5.1	Mounting a Narrow EUT in the Narrow Hand Phantom for Data Mode	423
A.1.5.2	Mounting a Wide EUT in the PDA Phantom for Data Mode	425
A.1.5.3	Mounting a Wide EUT in the Wide Grip Phantom for Data Mode	425
A.2	Test Systems Set-up	425
A.3	Test Setup—Instrumentation	427
Appendix B	Reporting of Test Results (Normative)	
B.1	Test Report Tables	432
B.2	EUT Measurement Data Files	433
B.3	Calculating Spatially Averaged Quantities	434
B.3.1	Total Radiated Power	434
B.3.1.1	Theta Dependent Phi TRP	435
B.3.1.2	Spiral Scan TRP	435
B.3.2	Near-Horizon Partial Radiated Power	437
B.3.2.1	Theta Dependent Phi NHPRP	438
B.3.2.2	Spiral Scan NHPRP	438
B.3.3	Total Isotropic Sensitivity	440
B.3.3.1	Theta Dependent Phi TIS	440
B.3.3.4	Near-Horizon Partial Isotropic Sensitivity	440
B.3.3.4.1	Theta Dependent Phi NHPIS	441
B.3.5	Upper Hemisphere Isotropic Sensitivity (UHS)	442
B.3.5.1	Theta Dependent Phi UHS	442
B.3.6	Partial Isotropic GNSS Sensitivity (PIGS)	443
B.3.6.1	Theta Dependent Phi PIGS	443
B.3.7	Calculations When Using the Spiral Scan TRP Measurement Method	443
B.3.7.1	Total Radiated Power	444
B.3.7.2	Near-Horizon Partial Radiated Power	446
B.4	3-D Plots	446
B.5	Range Reference Measurement Data File	447
B.6	Photographs and Identification of Hand Phantoms	447
B.7	Photographs and Identification of Forearm Phantoms	447
Appendix C	SAM Head and Hand Phantom Definitions and EUT Test Positions (Normative)	
C.1	SAM Head Phantom—Reference Information	448
C.2	Head Phantom Definitions and Requirements	449

	C.2.1	Head Phantom Definition	449
	C.2.2	Head Phantom Dielectric Parameters	450
	C.2.3	Head Fixturing Requirements	452
C.3		Hand Phantom—Reference Information	452
	C.3.1	Hand Anthropometric Research	452
	C.3.2	Hand Reference Dimensions	453
	C.3.3	Hand Reference Dielectric Parameters	458
C.4		Hand Phantom Definitions and Requirements	458
	C.4.1	Dielectric Parameter Requirements	459
	C.4.2	Hand Phantom Identification	459
	C.4.3	Hand Mechanical Requirements	459
	C.4.4	Hand Phantom Fixturing Requirements	460
	C.4.5	Monoblock Hand Phantom	460
	C.4.6	Fold Hand Phantom	462
	C.4.7	Narrow Data Hand Phantom	463
	C.4.8	PDA Grip Hand Phantom	463
	C.4.9	Wide Grip Hand Phantom	464
	C.4.10	Alternative Hand Phantoms	465
Appendix D		Power Measurement Considerations (Normative)	
	D.1	Power Measurement Equipment	466
	D.2	General Measurement Requirements	466
	D.2.1	Use of Spectrum Analyzers	467
	D.2.2	Use of Communication Testers	468
	D.2.3	Use of Power Meters	468
		D.2.3.1 Ratio of Reverse-to-Forward Signal Level	468
		D.2.3.2 Ratio of Reverse Signal Level-to-Noise	470
	D.3	TDMA	471
	D.4	GSM/GPRS (GMSK Modulation)	471
	D.5	EGPRS/EDGE (8PSK Modulation)	475
	D.6	AMPS	480
	D.7	CDMA	480
	D.8	WCDMA (UMTS)	483
	D.8.1	Determining the RBW/NBW Correction Factor	487
	D.9	LTE	490
	D.10	LTE Category M1	494
	D.11	LTE Category NB1 (NB-IoT)	495
	D.12	NR FR1 (Informative)	496
Appendix E		Total Isotropic Sensitivity and Total Radiated Power Derivations (Informative)	
	E.1	Total Isotropic Sensitivity	498
	E.1.1	Total Isotropic Sensitivity Estimator Based on RSS-Based Methods	502
	E.2	Total Radiated Power	504
	E.3	Conversion of Integrals to Summations of Discretely Sampled Pattern Data	506

Appendix F	Symmetry Pattern Antenna (Informative)	
F.1	Symmetry Pattern vs. Absolute Accuracy	510
Appendix G	Instructions for Calculating Standard Uncertainty Values (Normative)	
G.1	Mismatch	511
G.2	Cable Factor	512
G.3	Insertion Loss	513
G.4	Receiving Device (Spectrum Analyzer, Measurement Receiver or Base Station Simulator)	513
G.5	Signal Generator or Base Station Simulator	514
G.6	Gain of the Calibrated Reference Antenna	514
G.7	Measurement Distance	515
G.7.1	Offset of the Phase Center of the EUT from Center of Rotation	515
G.7.2	Offset of the Phase Center of the Calibrated Reference Antenna from Center of Rotation	515
G.7.3	Blocking Effect of the EUT on the Measurement Antenna (if too close)	516
G.7.3.1	VSWR	516
G.7.3.2	Chamber Standing Wave	518
G.7.4	Additional Measurement Uncertainties for Inadequate Measurement Distance	518
G.8	Signal Level Ripple Within Quiet Zone	519
G.8.1	Effect of Ripple on TRP and TIS Integration	520
G.8.1.1	Applying the Surface Standard Deviation	521
G.8.1.2	Analysis of Uncertainty vs. Error Contribution	521
G.8.2	Effect of Ripple on Range Reference Measurement	523
G.9	Influence Quantities	524
G.10	Uncertainties of Head, Hand and Positioning of EUT in the Hand and Against the Head Phantoms	526
G.10.1	Concept of Phantom and Positioning Uncertainties	526
G.10.2	Head Phantom Uncertainty	527
G.10.3	Hand Phantom Uncertainty	528
G.10.4	Head and Hand Phantom Fixtures Uncertainty	533
G.10.4.1	Experimental Evaluation	533
G.10.4.2	Numerical Evaluation	535
G.10.5	Phone Positioning Uncertainty	535
G.10.5.1	Experimental Evaluation	536
G.10.5.2	Numerical Evaluation	537
G.10.6	Estimation of Dielectric Parameter Measurement Uncertainties	538
G.10.7	Uncertainty for Reasonably Worst-case Head, Hand and EUT Positioning in the Hand and against the Head	540
G.10.8	Uncertainties of Hand Phantom Fixture and Phone Positioning in Data Mode Testing	542
G.11	Sensitivity Search Step Size	543
G.12	Coarse Sampling Grid in TIS Measurements	544
G.13	Miscellaneous Uncertainty	544
G.14	TIS Normalization Uncertainty	544
G.15	Effect of Theta Dependent Phi Optimization on TIS	545

G.16	Linearization of RSS Measurements	546
G.17	Uncertainty of RSS Data from EUT	546
G.18	Reporting Mechanism for RSS Data from EUT	546
G.19	Special Considerations for Notebooks	546
	G.19.1 Measurement Distance	546
	G.19.2 Offset of the Phase Center of the EUT from the Center of Rotation	547
	G.19.3 VSWR	548
	G.19.4 Chamber Standing Wave	548
	G.19.5 Phase Curvature Across the EUT	548
	G.19.6 Signal Level Ripple within the Quiet Zone	548
G.20	Uncertainty due to Difference in Gain over Different Channel Bandwidths ...	548
G.21	EUT Positioning/Repositioning Uncertainty	549
G.22	Test System Frequency Flatness Uncertainty	549
G.23	Effect of a Reduction in the Number of Test Samples on TIS Measurements .	551
G.24	Uncertainties of Forearm and Positioning of EUT on Forearm Phantom	551
	G.24.1 Forearm Phantom Uncertainty	551
	G.24.2 Wrist-worn Device Positioning Uncertainty	554
	G.24.3 Uncertainty for Reasonably Worst-case Forearm and EUT Positioning on Forearm.	556
Appendix H	Tissue Equivalent Dielectric Property Measurements (Normative)	
H.1	Measurement Techniques	558
H.2	Open-ended Coaxial Probe (OCP) Method	559
	H.2.1 OCP Equipment Set-up	561
	H.2.2 Measurement Procedure	563
H.3	TEM Transmission Line Method	564
	H.3.1 TEM Equipment Set-up	564
	H.3.2 Measurement Procedure	567
Appendix I	Assessment of Uncertainty Values using Simulation Tools (Normative)	
I.1	Introduction	569
I.2	Requirements for the Simulation Software	569
I.3	Simulation Software Validation	569
I.4	Phone Validation	569
I.5	Computation of the Uncertainty for Type B Evaluation	570
I.6	Computation of the Uncertainty for Type A Evaluation	570
I.7	Numerical Evaluation of Head and Hand Phantom Fixtures Uncertainty	570
I.8	Numerical Evaluation of Device Positioning Uncertainty	571
I.9	Numerical Evaluation of Head, Hand and Forearm Phantom Shape Uncertainty .	571
I.10	Numerical Evaluation of Head Phantom Support Material Uncertainty	572
Appendix J	Lab Repeatability Evaluation (Normative)	
Appendix K	Intermediate Channel Lists (Normative)	
K.1	CDMA Intermediate Channel List	574

K.2	GSM Intermediate Channel List	581
K.3	UMTS (WCDMA) Intermediate Channel List	582
K.4	LTE Intermediate Channel List	584
Appendix L	Notebook and Tablet Appendix (Normative)	
L.1	Purpose	588
L.2	Scope	588
L.3	Definitions	588
L.4	Equipment Under Test - Setup	588
L.5	Testing of Physically Reconfigurable Devices	589
L.6	Notebooks and Tablets with Extendable/Retractable Antennas	589
L.7	Multi-Protocol Devices	589
L.8	Free Space Testing	590
L.9	Chamber Placement	590
	L.9.1 Positioning a Notebook Relative to the Chamber Coordinate System	590
	L.9.1.1 Distributed Axes, Conical Cut Chamber	591
	L.9.1.2 Combined-Axes, Great Circle Chamber	592
	L.9.2 Positioning a Tablet Relative to the Chamber Coordinate System	592
	L.9.2.1 Distributed Axes, Conical Cut Chamber	593
	L.9.2.2 Combined-Axis, Great Circle Chamber	594
	L.9.3 Minimum Measurement Distance Considerations	594
L.10	Additional Measurement Uncertainty	594
	L.10.1 Ripple Uncertainty	594
	L.10.2 Uncertainty Due to Minimum Measurement Distance	595
	L.10.3 Additional Coarse Sampling Grid Uncertainty	595
Appendix M	Optional GSM, UMTS and LTE Bands (Informative)	
M.1	Optional Frequency Bands and Channel Configurations	596
M.2	Considerations in Measurements of TRP for LTE TDD UEs	599
M.3	Requirements for Measurement of Optional LTE Channel Bandwidths	599
Appendix N	Path Loss Errors Induced by Propagation Delay (Informative)	
N.1	Description and Overview	600
N.2	Verification Principles	600
N.3	CW Verification Procedure	601
Appendix O	Recommended Use Cases and Special Test Requirements (Informative)	
O.1	Purpose	602
O.2	Definitions	602
O.3	Testing Required-Head and Hand Phantom, and Free-Space Test Conditions	602
O.4	Testing Required - Hand Phantom Test Conditions	605
O.5	Testing Required—Free-Space Only	606
O.6	Testing Required—Wrist-Worn Test Conditions	608
O.7	Testing Not Required	609
O.8	LTE CA and LAA Test Requirements	609
	O.8.1 LTE CA TRP Test Requirements	609

O.8.2	LTE CA TIS Test Requirements	610
O.8.3	LTE LAA TIS Test Requirements	610
O.9	CatM1 and Cat-NB1 OTA Test Applicability	612
O.10	Special Test Requirements	612
O.10.1	LTE Relative Sensitivity on Intermediate Channels Test	612
O.10.2	Relative Measurement Testing Using Different Samples / Chambers	615
O.10.3	Clarification on Resets Between Measurements During A-GNSS Sensitivity Measurement	615
O.10.4	Conducted Performance Testing of 2 DL and 3 DL LTE CA	616
O.10.5	LTE CA Summary Tables	616
O.10.6	Waiver for LTE A-GLONASS OTA Testing when using SIB8 or SIB16	616
O.10.7	Modifications to LTE Category M1 Power Measurements	616
O.10.8	Sensitivity Factors for Numerical Evaluation of Phone Positioning Uncertainty for 3000 - 6000 MHz Range	616
O.10.9	Dipole Symmetry Allowances for Ripple Testing	617

Appendix P Integrated Device Appendix (Normative)

P.1	Purpose	618
P.2	Scope	618
P.3	Equipment Under Test - Setup	618
P.4	Required Testing	619
P.4.1	Free Space Testing	619
P.4.2	Body Worn Testing	619
P.5	Physically Reconfigurable Devices	619
P.6	Integrated Devices with Extendable/Retractable Antennas	620
P.7	Considerations for Externally-powered Devices	620
P.8	Multi-Protocol Devices	621
P.9	A-GNSS Testing for Integrated Devices	621
P.9.1	Testing Overview	621
P.9.2	Criteria	621
P.9.3	Reporting of Test Results	621
P.10	Chamber Placement	622
P.10.1	Positioning an Integrated Device Relative to the Chamber Coordinate System	622
P.10.2	Minimum Measurement Distance Considerations	623
P.10.3	Positioning an Integrated Device with a Removable Antenna Connected Directly to the Device via an RF Transmission Line (Such as a Coaxial Cable) Less Than 20 cm in Length	624
P.11	Additional Measurement Uncertainty	624
P.11.1	Ripple Uncertainty	624
P.11.2	Uncertainty Due to Minimum Measurement Distance	624
P.11.3	Additional Coarse Sampling Grid Uncertainty	624
P.12	Testing of Cellular Desense due to Simultaneous Operation of 802.11 Radios for Integrated Devices	625
P.12.1	Scope	625
P.12.2	Testing Overview	625
P.12.3	Testing Procedure	625

	P.12.4	Criteria	626
Appendix Q	Wrist-worn Device Appendix (Normative)		
	Q.1	Purpose	627
	Q.2	Scope	627
	Q.3	Equipment Under Test -Setup	627
	Q.4	Wrist-worn Testing	628
	Q.4.1	Wrist-Worn Device A-GNSS Testing Requirements	628
	Q.4.1.1	A-GNSS Sensitivity Criteria	628
	Q.4.1.2	A-GNSS Signal Level for Pattern Measurement	628
	Q.4.1.3	A-GNSS Linearization Dynamic Range Reduction	628
	Q.5	Forearm Phantom Definitions and Requirements	629
	Q.5.1	Forearm Phantom Dielectric Parameter Requirements	629
	Q.5.2	Forearm Phantom Identification	629
	Q.5.3	Forearm Phantom Fixturing Requirements	629
	Q.5.4	Forearm Phantom	629
	Q.5.5	Forearm Phantom - Reference Information	630
	Q.6	Positioning Guidelines for wrist-worn Devices	631
	Q.6.1	Positioning of wrist-worn EUT Relative to the Chamber Coordinate System. . . .	631
	Q.6.2	Mounting a Wrist-Worn EUT on the Forearm Phantom	632
	Q.7	OTA Limits for wrist-worn Devices	641
	Q.8	OTA Reporting for wrist-worn Devices	642
	Q.9	Additional Measurement Uncertainty	642
Appendix R	Stand-Alone GNSS Test Methodology and Test Procedure (Informative)		
	R.1	Purpose	643
	R.2	Scope	643
	R.3	Communication Protocol	643
	R.3.1	Stand-Alone GNSS Acquisition Sensitivity Method	643
	R.3.2	Stand-Alone GNSS Tracking Sensitivity Method	645
	R.4	Procedure	646
	R.5	Radiated 3D C/N0 Pattern Measurement	646
	R.5.1	Stand-alone GNSS Acquisition Sensitivity Method	647
	R.5.2	Stand-alone GNSS Tracking Sensitivity Method	647
	R.6	Radiated GNSS Sensitivity Measurement	647
	R.6.1	Stand-alone GNSS Acquisition Sensitivity Method	648
	R.6.2	Stand-alone GNSS Tracking Sensitivity Method	649
	R.7	Criteria	650
	R.8	Reporting of Test Results	651
Appendix S	Selection of Test Channels for LTE CA OTA Testing (Informative)		
	S.1	Purpose	654
	S.2	Examples	654
Appendix T	Bluetooth Basic Rate (Informative)		
	T.1	Bluetooth Basic Rate TRP Test Procedure	662

T.2	OTA Reporting for Bluetooth Basic Rate TRP	663
T.3	Bluetooth Basic Rate TIS Test Procedure	663
T.4	OTA Reporting for Bluetooth Basic Rate TIS	665
Appendix U	Phantom Material Selection Based on Test Frequency	
Appendix V	ZigBee (Informative)	
V.1	ZigBee TRP Test Procedure	667
V.2	ZigBee TIS Test Procedure	669
V.3	ZigBee Reporting the Results	671
V.4	ZigBee Command Module and Test Case Flow	672
Appendix W	List of Cited References (Informative)	
Appendix X	Change History	

List of Figures

Figure 2-1	Great Circle Cuts and Measurement Points (for 30 Degree Grid)	37
Figure 2-2	The Great Circle T0 Cut	37
Figure 3-1	Spherical Coordinate System	44
Figure 3-2	Measurement Antenna Polarizations	44
Figure 3-3	Spherical Coverage and Orientation of Support Structure with Respect to Coordinate System	45
Figure 3-4	Illustrations of Typical Distributed-Axes System (a) and Combined-Axes System (b)	46
Figure 3-5	Phi-Axis Test Geometry	48
Figure 3-6	Theta-Axis Test Geometry	49
Figure 3-7	Illustration of Alternate Probe Positions Allowed for Theta-Axis Test	51
Figure 3-8	Illustration of the Increase in Test Volume for Notebooks	53
Figure 3-9	Illustration of the Additional Phi-Axis Ripple Test Locations for Notebooks	54
Figure 3-10	Illustration of the Additional Theta-Axis Ripple Test Locations for Notebooks	54
Figure 3-11	Phi-Axis Test Geometry for a Typical Distributed-Axes System (a), and a Typical Combined-Axes System (b)	56
Figure 3-12	Theta-Axis Test Geometry for a Typical Distributed-Axes System (a), and a Typical Combined-Axes System (b)	57
Figure 3-13	Example Illustrating Some Allowed Alterations of Test Setup for Phi-Axis	57
Figure 3-14	Example Illustrating Alternate Positions and Allowed Alterations for Theta-Axis Test	58
Figure 3-15	Geometry for Law of Cosines Range Length Adjustment	59
Figure 4-1	Theoretical Case for Determining Path Loss	60
Figure 4-2	Typical Configuration for Measuring Path Loss	61
Figure 4-3	Cable Reference Calibration Configuration	62
Figure 5-1	Spiral Scan Measurement Points (Left) and Standard (Equally Spaced) Measurement Points (Right)	111
Figure 6-1	Illustration of Relative Sensitivity on Intermediate Channels Test	168
Figure A-1	EUT Vertical and Horizontal Reference Lines	406
Figure A-2	EUT Coordinate System - Free Space	407
Figure A-3	SAM Head Phantom with Mouth and Ear Locations	408
Figure A-4	EUT Position: "Cheek" Or "Touch" Positions for Right Ear	409
Figure A-5	Definition of Coordinate System for SAM Head Phantom	409
Figure A-6	Alternate Coordinate System for SAM Head Phantom	410
Figure A-7	Choosing the Correct Hand Phantom	411
Figure A-8	Optional Head Phantom Mask Spacer on SAM Head Phantom	412
Figure A-9	Head and Hand Configuration (a) with and (b) without Mask Spacer (Right), (c) with and (d) without Mask Spacer (Left)	414
Figure A-10	Alignment Tool A	415
Figure A-11	Monoblock Palm Spacer	416
Figure A-12	Alignment Tool B and Usage with Fold EUT	417
Figure A-13	Usage of Alignment Tool B with Open Portrait Slide EUT	417
Figure A-14	Fold Palm Spacer	418

Figure A-15	PDA Palm Spacer	419
Figure A-16	Positioning of Wide EUT with Respect to PDA Palm Spacer	419
Figure A-17	Wide Grip Hand Phantom Contact Points	420
Figure A-18	Wide Grip Palm Spacer Contact Surfaces	421
Figure A-19	Insulating Grommet to Prevent Side Key Actuation	421
Figure A-20	Wide Grip EUT Positioning Example With Rounded Corner, Side Key Grommet	422
Figure A-21	EUT Display Alignment Features	423
Figure A-22	Definition of Coordinate System for EUT with Hand Phantom in Data Mode	423
Figure A-23	Measuring a Narrow EUT in Alignment Tool A for Hand Only (“Data Mode”) Testing	424
Figure A-24	Narrow Data Palm Spacer	425
Figure A-25	Typical Setup for a Combined-Axes System	426
Figure A-26	Typical Setup for a Distributed-Axes System	427
Figure A-27	Simplified Block Diagram Showing a Common Configuration for the use of a Base Station Simulator for TRP Measurements	428
Figure A-28	Simplified Block Diagram Showing a Common Configuration for TIS Measurements	428
Figure A-29	Simplified Block Diagram for TRP Measurements Using a Spectrum Analyzer	429
Figure A-30	Simplified Block Diagram for TRP Measurements Using a Spectrum Analyzer with a Power Divider	429
Figure A-31	Simplified Block Diagram Illustrating a Method with External Amplifiers	430
Figure A-32	Simplified Block Diagram for TRP Measurements Using Dual Spectrum Analyzers	430
Figure A-33	Simplified Block Diagram for TRP Measurements Using Dual Spectrum Analyzers and a Power Divider	431
Figure C-1	Front, Back and Side View of the SAM Head Phantom	449
Figure C-2	CTIA SAM Head Phantom	450
Figure C-3	Pictorial of Human Hand with Dimension Labels	456
Figure C-4	Open Hand Phantom	457
Figure C-5	Conformal Fingertip Weight Container	460
Figure C-6	Measuring the Hand Phantom Material Stiffness	460
Figure C-7	Monoblock Hand Phantom; (a) Left Hand; (b) Right Hand	461
Figure C-8	Fold Hand Phantom; (a) Left Hand; (b) Right Hand	462
Figure C-9	Narrow Data Hand Phantom; (a) Left Hand; (b) Right Hand	463
Figure C-10	PDA Hand Phantom; (a) Left Hand; (b) Right Hand	464
Figure C-11	Wide Grip Hand Phantom; (A) Left Hand, (B) Right Hand	465
Figure D-1	Use of Auxiliary Antenna for Forward Channel	469
Figure D-2	Use of Measurement Antenna for Forward Channel	470
Figure D-3	Sample GSM Power Envelope with Acceptable Resolution	473
Figure D-4	Sample GSM Power Envelope with Insufficient Resolution	474
Figure D-5	Sample GSM Pulses Showing Increase in Noise as Signal Approaches Trigger Level	474
Figure D-6	Sample 8-PSK Power Envelope with Acceptable Resolution	476
Figure D-7	Multiple 8-PSK Pulses with Random Data Content	477
Figure D-8	Example Of GMSK Bursts Mixed in with 8-PSK Data	478

Figure D-9	Sample 8-PSK Pulses Showing Mis-triggering and Increase in Noise at Low Levels . . .	478
Figure D-10	Sample Multislot 8-PSK Pulses	479
Figure D-11	Bad 8-PSK Multislot Trace Resulting from GMSK Burst	479
Figure D-12	Bad 8-PSK Multislot Trace Resulting from Mis-triggering	480
Figure D-13	Comparison of CDMA Power Envelope Using Peak, RMS, and Sample Detectors	482
Figure D-14	Example of Running Average Used to Qualify Sample Detector Sweep	482
Figure D-15	Example of Running Average when More Points are Used	483
Figure D-16	Example of Valid Frequency Response Trace Using RMS Detector	485
Figure D-17	Example of Valid Frequency Response Trace Using Sample	486
Figure D-18	Example of a Signal Drop-out During an RMS Sweep.	486
Figure D-19	Illustration of the Difference Between Noise Bandwidth and Data Point Width in the Integrated Channel Power Formula	487
Figure D-20	Comparison of a Gaussian Shaped RBW Filter to a Rectangular NBW with the Same Frequency Bandwidth.	488
Figure D-21	Example of a Flat Top Filter with 30 kHz RBW	489
Figure D-22	Example of Valid LTE Frequency Response Trace Using RMS Detector.	493
Figure D-23	Example of Valid LTE Wideband Time Response Trace Using RMS Detector	494
Figure E-1	TIS	498
Figure E-2	TRP	504
Figure G-1	Ten Locations of Dielectric Measurements at the Brick Hand Surface.	531
Figure G-2	Ten Locations of Dielectric Measurements at the Fold Hand Surface	531
Figure G-3	Ten Locations of Dielectric Measurements at the Narrow Data Hand Surface	532
Figure G-4	Ten Locations of Dielectric Measurements at the PDA Hand Surface.	532
Figure G-5	Ten Locations for Dielectric Measurement of the Wide Grip Hand Surface	533
Figure G-6	Phone Positioning Uncertainty Components	538
Figure G-7	Coordinate System for Dielectric Test Locations	553
Figure G-8	Twelve Locations for Dielectric Measurements on the Forearm Phantom.	554
Figure G-9	Forearm Positioning Uncertainty Components.	556
Figure H-1	Setup for Fixed Displacement Measurement	560
Figure H-2	Setup for Fixed Pressure Measurement	561
Figure H-3	Open-ended Coaxial Probe with Inner and Outer Radii A and B, Respectively . . .	562
Figure H-4	Calibration of VNA Using a Dummy Probe Whose Electrical Length Is the Same as the Actual OCP	563
Figure H-5	TEM Transmission Line Dielectric Measurement Method Setup	565
Figure H-6	Geometry of the Sample Holder (Dielectric Test Cell, Dimensions in mm)	566
Figure H-7	Construction Diagram of Strip-line TEM Sensor (All Dimensions in mm)	567
Figure L-1	Position of Notebook Relative to the Chamber Coordinates	591
Figure L-2	Position of Tablet Relative to the Chamber Coordinates	593
Figure O-1	Logic for determining the LAA combination used for full TIS testing of Band 46 . . .	611
Figure P-1	Internal Antenna.	623
Figure P-2	Direct Connect External Antenna (It Does Not Matter Where the Antenna Is Located as You Will Center on the Device)	623

Figure Q-1	Forearm Phantom With Target Test Position.	630
Figure Q-2	Cartesian Coordinate System For Forearm Phantom	632
Figure Q-3	Definition of Plane J and Plane K on the Forearm Phantom	633
Figure Q-4	Local Coordinate System for a wrist-worn Device	634
Figure Q-5	Definition of Plane A and Plane B on a wrist-worn Device.	635
Figure Q-6	Alignment of Plane A with Plane K and Plane B with Plane J when a wrist-worn device, which can be laid out flat, is mounted on the forearm phantom	636
Figure Q-7	Alignment of Plane A with Plane K and Plane B with Plane J when a wrist-worn device with a pre-formed wrist band is mounted on the forearm phantom	637
Figure Q-8	Location of Plane B on a wrist-worn Device with a Symmetric Pre-formed Shape	638
Figure Q-9	Examples of Correctly Mounting the Device on the Forearm Phantom by Keeping the Main Module Parallel to the Surface of the Forearm Phantom	639
Figure Q-10	Example of Incorrectly Mounting the Device on the Forearm Phantom by not Keeping the Main Module Parallel to the Surface of the Forearm Phantom	640
Figure Q-11	Two Orientations of EUT on Forearm Phantom Representing the Left and Right Wrist	641
Figure V-1	TRP Block Diagram Set Up for ZigBee	669
Figure V-2	TIS Block Diagram Set Up for ZigBee	671
Figure V-3	ZigBee Total Radiated Power Test Case Command Flow	678
Figure V-4	ZigBee Total Isotropic Sensitivity Test Case Command Flow	679

List of Tables

Table 3-1	Minimum Measurement Distance for Handheld EUTs	40
Table 3-2	Derivation of Minimum Measurement Distance for Handheld EUTs (Informative Only). 41	
Table 3-3	Quiet Zone Accuracy Frequencies	43
Table 3-4	Example Scenarios for Reduced Angular Resolution Ripple Tests	52
Table 4-1	Test Frequencies for the Reference Measurement	63
Table 4-2	Example Range Reference Measurement Data Record	69
Table 4-3	Sample Range Reference Measurement Data File Format	72
Table 5-1	CDMA Base Station Parameters—Cellular Band	77
Table 5-2	CDMA Base Station Parameters—PCS Band	77
Table 5-3	CDMA Base Station Parameters—AWS-1 Band	78
Table 5-4	CDMA Test Frequencies	78
Table 5-5	CDMA Minimum TRP Level (in dBm) Requirements for the Primary Mechanical Mode 80	
Table 5-6	PCL Setting for GSM 850.	83
Table 5-7	PCL Setting for GSM 1900.	83
Table 5-8	GSM RX and TX Test Frequencies	84
Table 5-9	GSM Minimum TRP Level (in dBm) Recommended Limits for the Primary Mechanical Mode	85
Table 5-10	PCL and Gamma Setting for GMSK Modulation in GSM 850 Band	86
Table 5-11	PCL and Gamma Setting for GMSK Modulation in GSM 1900 Band	86
Table 5-12	Coding Scheme (CS) Setting for GMSK Modulation in Either GSM 850 or GSM 1900 Band.	86
Table 5-13	GPRS Minimum TRP Level (in dBm) Recommended Limits for the Primary Mechanical Mode	87
Table 5-14	PCL and Gamma Setting for 8-PSK Modulation (EDGE) in GSM 850 Band	89
Table 5-15	PCL and Gamma Setting for 8-PSK Modulation (EDGE) in GSM 1900 Band	89
Table 5-16	Modulation Coding Scheme (MCS) Setting for 8-PSK Modulation (EDGE) in Either GSM 850 or GSM 1900 Band	89
Table 5-17	EGPRS Minimum TRP Level (in dBm) Recommended Limits for the Primary Mechanical Mode	90
Table 5-18	UMTS RX and TX Test Frequencies	91
Table 5-19	UMTS Minimum TRP Level (in dBm) Recommended Limits for the Primary Mechanical Mode	92
Table 5-20	LTE TRP Measurements Table for the Primary Mechanical Mode	94
Table 5-21	LTE Minimum TRP Level (in dBm) Requirements for the Primary Mechanical Mode . 97	
Table 5-22	CDMA 1xEV-DO Base Station Parameters - Cellular Band	100
Table 5-23	CDMA 1xEV-DO Base Station Parameters - PCS Band	100
Table 5-24	CDMA 1xEV-DO Base Station Parameters - AWS-1 Band	100
Table 5-25	CDMA 1xEV-DO DATA Minimum TRP Level (in dBm) Requirements for the Primary Mechanical Mode	101

Table 5-26	CDMA 1xRTT Data Base Station Parameters - Cellular Band	104
Table 5-27	CDMA 1xRTT Data Base Station Parameters - PCS Band	104
Table 5-28	CDMA 1xRTT Data Base Station Parameters - AWS-1 Band	105
Table 5-29	CDMA 1xRTT Data Minimum TRP Level (in dBm) Requirements for the Primary Mechanical Mode	106
Table 5-30	LTE Carrier Aggregation Mode (2 Downlink Carriers, 1 Uplink Carrier) TRP Measurements Table for the Primary Mechanical Mode	113
Table 5-31	LTE Carrier Aggregation Mode (2 Downlink Carriers, 1 Uplink Carrier) TRP Criteria Table for the Primary Mechanical Mode	119
Table 5-32	LTE Carrier Aggregation Mode (3 Downlink Carriers, 1 Uplink Carrier) TRP Measurements Table for the Primary Mechanical Mode	127
Table 5-33	LTE Carrier Aggregation Mode (3 Downlink Carriers, 1 Uplink Carrier) TRP Criteria Table for the Primary Mechanical Mode	143
Table 5-34	LTE Category M1 TRP Measurements Table for the Primary Mechanical Mode	155
Table 5-35	LTE Cat-M1 Minimum TRP Level (in dBm) Requirements for the Primary Mechanical Mode	156
Table 5-36	LTE Category NB1 TRP Measurements Table for Stand-alone (SA) Operation Using p/4 QPSK (15 kHz Sub-carrier Spacing) in the Primary Mechanical Mode	158
Table 5-37	LTE category NB1 TRP level (dBm) for Stand-alone (SA) Operation Using p/4 QPSK (15 kHz Sub-carrier Spacing) in the Primary Mechanical Mode	159
Table 5-38	NR FR1 TRP Measurements Table for the Primary Mechanical Mode	161
Table 6-1	CDMA Maximum C-TIS Level (in dBm) Requirements for the Primary Mechanical Mode	169
Table 6-2	GSM Maximum C-TIS Level (in dBm) Recommended Limits for the Primary Mechanical Mode	173
Table 6-3	GPRS Maximum C-TIS Level (in dBm) Recommended Limits for the Primary Mechanical Mode	178
Table 6-4	EGPRS Maximum C-TIS Level (in dBm) Recommended Limits for the Primary Mechanical Mode	183
Table 6-5	UMTS Maximum C-TIS Level (in dBm) Recommended Limits for the Primary Mechanical Mode	187
Table 6-6	LTE TIS Measurements Table for the Primary Mechanical Mode	189
Table 6-7	Uplink Reference Measurement Channel Table (Uplink Reference Measurement Channels Are per Annexes A.2.2 and A.2.3 of 3GPP TS 36.521-1 with the Exceptions Noted in the Table for Band 13)	190
Table 6-8	LTE Maximum C-TIS Level (in dBm) Requirements for the Primary Mechanical Mode 194	
Table 6-9	CDMA 1xEV-DO Data Maximum C-TIS Level (in dBm) Requirements for the Primary Mechanical Mode	200
Table 6-10	CDMA 1xRTT Data Maximum C-TIS Level (in dBm) Requirements for the Primary Mechanical Mode	204
Table 6-11	Maximum TX Power Settings and Mid-Channel Test Channels for UMTS	212
Table 6-12	A-GPS L1 Test Parameters for UMTS	213
Table 6-13	Maximum TX Power Settings and Mid-Channel Test Channels for GSM	214
Table 6-14	A-GPS L1 Test Parameters for GSM	215
Table 6-15	Mid-Band Test Channel Settings for LTE	217

Table 6-16	A-GPS L1 Test Parameters for LTE	220
Table 6-17	A-GLONASS Test Parameters for LTE.	224
Table 6-18	Mid-band Test Channel Settings for LTE Cat-M1	226
Table 6-19	A-GPS L1 Maximum TIS/UHIS/PIGS Level (in dBm) Requirements for the Primary Mechanical Mode for Devices Held to the Head for Voice	231
Table 6-20	A-GPS L1 Maximum TIS/UHIS/PIGS Level (in dBm) Requirements for the Primary Mechanical Mode for Integrated Devices	240
Table 6-21	A-GPS L1 Maximum TIS Level (in dBm) Requirements for the Primary Mechanical Mode for Wrist-Worn Devices	244
Table 6-22	A-GLONASS with Maximum TIS/UHIS/PIGS Level (in dBm) Requirements for the Primary Mechanical Mode for Devices Held to the Head for Voice	248
Table 6-23	A-GLONASS with Maximum TIS/UHIS/PIGS Level (in dBm) Requirements for the Primary Mechanical Mode for Integrated Devices	254
Table 6-24	A-GLONASS with Maximum TIS LEVEL (in dBm) Requirements for the Primary Mechanical Mode for Wrist-worn Devices	257
Table 6-25	LTE Carrier Aggregation Mode (2 Downlink Carriers, 1 Uplink Carrier) TIS Measurements Table for the Primary Mechanical Mode	271
Table 6-26	LTE Maximum C-TIS Level Requirements for PCC and SCC in Carrier Aggregation Mode (2 Downlink Carriers, 1 Uplink Carrier) for the Primary Mechanical Mode	282
Table 6-27	LTE Carrier Aggregation Mode (3 Downlink Carriers, 1 Uplink Carrier) TIS Measurements Table for the Primary Mechanical Mode	296
Table 6-28	LTE Maximum C-TIS Level Requirements for PCC, SCC1, and SCC2 in Carrier Aggregation Mode (3 Downlink Carriers, 1 Uplink Carrier) for the Primary Mechanical Mode	317
Table 6-29	Sample Size and Pass/Fail Criteria for MBS Sensitivity Search Procedure.	358
Table 6-30	MBS Maximum TIS/NHPIS \pm 45/NHPIS \pm 30 Level (in DBM) Requirements for the Primary Mechanical Mode	359
Table 6-31	LTE Category M1 TIS Measurements Table for the Primary Mechanical Mode	364
Table 6-32	LTE Cat-M1 Maximum C-TIS Level (in dBm/1080 kHz) Requirements for the Primary Mechanical Mode	367
Table 6-33	LTE LAA Carrier Aggregation Mode (2 Total Downlink Carriers with 1 Licensed Carrier, 1 Uplink Carrier) TIS Measurements Table for the Primary Mechanical Mode	368
Table 6-34	LTE LAA Carrier Aggregation Mode (3 Total Downlink Carriers with 2 Licensed Carriers, 1 Uplink Carrier) TIS Measurements Table for the Primary Mechanical Mode	370
Table 6-35	LTE Maximum C-TIS Level for All Antennas (in dBm) Requirements for PCC and SCC in Carrier Aggregation Mode (2 Downlink Carriers, 1 Uplink Carrier) for the Primary Mechanical Mode	377
Table 6-36	LTE Maximum C-TIS Level for All Antennas (in dBm) Requirements for PCC, SCC1, and SCC2 in Carrier Aggregation Mode (3 Downlink Carriers, 1 Uplink Carrier) for the Primary Mechanical Mode	379
Table 6-37	LTE Category NB1 TIS/C-TIS Measurements Table for Stand-alone (SA) Operation Using QPSK (15 kHz Sub-carrier Spacing) in the Primary Mechanical Mode	385
Table 6-38	LTE Category NB1 TIS Level (dBm) For Stand-alone (SA) Operation Using QPSK (15 kHz Sub-carrier Spacing) In the Primary Mechanical Mode	387
Table 6-39	NR FR1 TIS Measurements Table for the Primary Mechanical Mode1	389
Table 7-1	Standard Uncertainty Conversion Factors	391

Table 7-2	TRP Standard Uncertainties for the Contributions in the EUT Measurement Part . . .	394
Table 7-3	Standard Uncertainties for the Contributions to the Reference Measurement	395
Table 7-4	TIS Standard Uncertainties for the Contributions in the EUT Measurement Part . . .	397
Table 7-5	Standard Uncertainties for the Contributions to the Reference Measurement	399
Table 7-6	Additional Uncertainties Between Relative Measurement vs. Full TRP Measurement . .	401
Table 7-7	Additional Uncertainties Between Relative Measurement vs. Full TIS Measurement . .	403
Table 7-8	Expanded Uncertainty Maximum Limits for Different Configurations for TRP and TIS . .	404
Table C-1	Dielectric Properties of the Tissue-equivalent Liquid	451
Table C-2	Hand Phantom Dimensions	453
Table C-3	Hand Dielectric Parameters	458
Table C-4	Range of Monoblock-like Device Sizes Suitable for Use with Monoblock Hand Phantom	461
Table C-5	Range of Fold Device Sizes Suitable for Use with Fold Hand Phantom	462
Table C-6	Range of Narrow Data Device Sizes Suitable for Use with Narrow Data Hand Phantom	463
Table C-7	Range of PDA Device Sizes Suitable for Use with PDA Hand Phantom	463
Table C-8	Range of EUT Sizes Suitable for Use With Wide Grip Hand Phantom	464
Table D-1	Broadband Power Mode Measurement Requirements	492
Table D-2	LTE Category M1 Broadband Power Mode Measurement Requirements	495
Table D-3	Broadband Power Mode Measurement Requirements For NR FR1	496
Table G-1	Contributions for Inadequate Measurement Distance	519
Table G-2	Standard Uncertainties for the Head, Hand and EUT Positioning in the Hand and Against the Head	526
Table G-3	Example of Uncertainty Template for Dielectric Constant (ϵ_r') or Conductivity (σ) Measurement at a Specific Frequency Band	539
Table G-4	Example Of Uncertainty Assessment For Reasonably Worst-case Head, Hand and EUT Positioning in the Hand and against the Head	541
Table G-5	Example of Uncertainty Assessment for Hand Phantom, Fixture and Phone Positioning in Data Mode Testing	543
Table G-6	Additional Measurement Uncertainties for Large Form Factor Devices	547
Table G-7	Coordinates of Ten Locations for Dielectric Measurements on the Forearm Phantom	552
Table G-8	Example Of Uncertainty Assessment for Reasonably Worst-case Forearm and EUT Positioning on Forearm	556
Table K-1	CDMA 800 Intermediate Channel List	574
Table K-2	CDMA 1900 Intermediate Channel List	576
Table K-3	CDMA 2100/1700 Band (3GPP2 Band Class 15) Intermediate Channel List	579
Table K-4	UMTS 850 Intermediate Channel List	582
Table K-5	UMTS 1900 Intermediate Channel List	582
Table K-6	UMTS 2100/1700 Intermediate Channel List	583
Table K-7	LTE Intermediate Channel Measurements Table	584
Table M-1	GSM Frequency Bands	596

Table M-2	GSM Channels	596
Table M-3	UMTS Frequency Bands	596
Table M-4	UMTS Channels	597
Table M-5	LTE Frequency Bands	597
Table M-6	LTE TRP Channels and RB Allocations	597
Table M-7	LTE TIS Channels and RB Allocations	598
Table O-1	CA Test Reduction Table	604
Table O-2	Data-Only Integrated Device Radiated Test Applicability	607
Table O-3	Circuit-Switched Voice or VoLTE-Capable Integrated Device Radiated Test Applicability	607
Table O-4	Cellular Radio Mode test Requirements for Data-Only Devices	608
Table O-5	LTE Relative Sensitivity on Intermediate Channels	613
Table Q-1	Selection of Statistics from US Army Data on Enlisted Personnel	631
Table Q-2	Standard Uncertainties for the Forearm, and EUT Positioning on the Forearm.	642
Table R-1	Message definition and description for Stand-Alone GNSS Acquisition Sensitivity Method	644
Table R-2	GPS L1 Test Parameters for Stand-Alone GNSS Acquisition Sensitivity Method	648
Table R-3	GLONASS Test Parameters for Stand-Alone GNSS Acquisition Sensitivity	649
Table R-4	Stand-alone GPS L1 Maximum TIS/UHIS/PIGS Level (In DBM) Requirements for the Primary Mechanical Mode	650
Table R-5	Stand-alone GLONASS Maximum TIS/UHIS/PIGS Level (In DBM) Requirements for the Primary Mechanical Mode	650
Table R-6	Stand-alone GPS L1 Maximum TIS/UHIS/PIGS Level (In DBM) Requirements for the Primary Mechanical Mode	652
Table R-7	Stand-alone GLONASS Maximum TIS/UHIS/PIGS Level Requirements for the Primary Mechanical Mode	653
Table S-1	CA TRP where the PCC and SCC/SCC1 are Intra-band	656
Table S-2	CA TRP where the PCC and SCC/SCC1 are Intra-band	656
Table S-3	CA TIS	657
Table S-4	Band 66 Intra-band, Non-contiguous Carriers (when the PCC is in Band 66)	660
Table S-5	Band 66 Intra-band, Non-contiguous Carriers	660
Table T-1	Bluetooth Basic Rate Communication Settings for TRP	662
Table T-2	RF TX Measurement Equipment Settings for Bluetooth Basic Rate	662
Table T-3	Bluetooth Basic Rate Test Channels for TRP using “Loop Back” or “TX Mode”	663
Table T-4	Bluetooth Basic Rate TRP Test Results	663
Table T-5	Bluetooth Basic Rate Communication Settings for TIS	664
Table T-6	RF RX Sensitivity Measurement for Bluetooth Basic Rate	664
Table T-7	Bluetooth Basic Rate Test Channels for TIS using “Loop Back”	664
Table T-8	Bluetooth Basic Rate TIS Test Results	665
Table V-1	Spectrum Analyzer Settings for ZigBee	667
Table V-2	ZigBee Channel Settings	668
Table V-3	ZigBee Parameter Settings for RSS Method	670
Table V-4	ZigBee Total Radiated Power	671
Table V-5	ZigBee Total Isotropic Sensitivity	672

Table W-1 List of Cited References 680

Section 1 Introduction

1.1 Purpose

The purpose of this test plan is to define the CTIA Certification program test requirements for performing Radiated RF Power and Receiver Performance measurements on wireless devices.

1.2 Scope

This test plan defines general requirements for equipment configurations, laboratory techniques, test methodologies, and evaluation criteria that must be met in order to ensure the accurate, repeatable, and uniform testing of wireless devices to ensure that they meet CTIA Certification standards. This test plan also defines a portion of the requirements that a laboratory must satisfy to qualify for and maintain CTIA Certification Authorized Testing Laboratory (ATL) status (contact the CTIA Certification Program staff for complete ATL requirements).

This test plan does not provide specific test equipment configurations or detailed test instructions by which to execute certification testing. Such documentation and procedures must be presented by the ATL as part of the CTIA Certification Authorization process and subsequently maintained and employed by the ATL to remain authorized to perform Certification testing.

1.3 Applicable Documents

The following documents are referenced in this Test Plan. For undated references, the latest edition of the referenced document applies. For dated references, only the edition cited applies. In the case where the same reference is dated and undated, the specific reference to the document in the test plan shall be considered to determine if the dated or undated version is to be used.

3GPP TS 05.05: Radio transmission and reception.

3GPP TS 25.331, V8.2.0 (2002-06): Radio Resource Control (RRC); Protocol Specification.

3GPP TS 34.108, V8.2.0 (2006-10): Common test environments for User Equipment (UE); Conformance testing.

3GPP TS 34.108: Common test environments for User Equipment (UE); Conformance testing.

3GPP TS 34.109: Terminal logical test interface; Special conformance testing functions.

3GPP TS 34.121-1: Radio transmission and reception (FDD); Part 1: Conformance specification.

3GPP TS 34.171 V7.1.0 (2004-08): Terminal conformance specification; Assisted Global Positioning System (A-GPS); Frequency Division Duplex (FDD).

3GPP TS 36.101: Evolved Universal Terrestrial Radio Access (E-UTRA); User Equipment (UE) radio transmission and reception.

3GPP TS 36.133: Evolved Universal Terrestrial Radio Access (E-UTRA); Requirements for support of radio resource management.

3GPP TS 36.211: Evolved Universal Terrestrial Radio Access (E-UTRA); Physical Channels and Modulation.

3GPP TS 36.214: Evolved Universal Terrestrial Radio Access (E-UTRA); Physical layer; Measurements.

3GPP TS 36.355: Evolved Universal Terrestrial Radio Access (E-UTRA); LTE Positioning Protocol (LPP).

3GPP TS 36.508: Evolved Universal Terrestrial Radio Access (E-UTRA) and Evolved Packet Core (EPC); Common test environments for User Equipment (UE) conformance testing.

3GPP TS 36.521-1: Evolved Universal Terrestrial Radio Access (E-UTRA); User Equipment (UE) conformance specification Radio transmission and reception; Part 1: Conformance Testing.

3GPP TS 37.571-1: Universal Terrestrial Radio Access (UTRA) and Evolved UTRA (E-UTRA) and Evolved Packet Core (EPC); User Equipment (UE) conformance specification for UE positioning; Part 1: Conformance test specification.

3GPP TS 37.571-5: Universal Terrestrial Radio Access (UTRA) and Evolved UTRA (E-UTRA) and Evolved Packet Core (EPC); User Equipment (UE) conformance specification for UE positioning; Part 5: Test scenarios and assistance data.

3GPP TS 38.508-1: 5GS; User Equipment (UE) conformance specification; Part 1: Common test environment.

3GPP TS 38.521-1: NR; User Equipment (UE) conformance specification; Radio transmission and reception; Part 1: Range 1 Standalone

3GPP TS 44.031: Location Services (LCS); Mobile Station (MS) - Serving Mobile Location Centre (SMLC) Radio Resource LCS Protocol (RRLP).

3GPP TS 45.005: Radio transmission and reception.

3GPP TS 51.010-1: Mobile Station (MS) conformance specification; Part 1: Conformance specification.

3GPP TS 51-010-1 V8.3.0 (2009-09): Mobile Station (MS) conformance specification; Part 1: Conformance specification.

Alvin R. Tilley and Henry Dreyfuss Associates, *The Measure of Man and Woman: Human Factors in Design*, Wiley, Dec. 31, 2001.

Beard, B.B, et al., "Comparisons of Computed Mobile Phone Induced SAR in the SAM Phantom to That in Anatomically Correct Models of the Human Head", *IEEE Transactions On Electromagnetic Compatibility*, Vol. 48, No. 2, p. 397 - 407, May 2006.

Bugbee, William D., M.D. and Botte, Michael J., M.D., "Surface Anatomy of the Hand: The Relationships Between Palmar Skin Creases and Osseous Anatomy", *Clinical Orthopaedics and Related Research*, Vol. 296, pp. 122 - 126, 1993.

EN 50361:2001: Basic Standard for the measurement of Specific Absorption rate related to human exposure to electromagnetic fields from mobile phones (300 MHz - 3 GHz).

ETSI TR 100 028 Parts 1 & 2: Electromagnetic compatibility and Radio spectrum Matters (ERM); Uncertainties in the measurement of mobile radio equipment characteristics, 2001.

ETSI TR 102 273 V1.2.1: Electromagnetic compatibility and Radio spectrum Matters (ERM); Improvement of radiated methods of measurement (using test sites) and evaluation of the corresponding measurement uncertainties, 2001.

Gabriel, C., "Tissue Equivalent Material for Hand Head phantoms", *Physics in Medicine and Biology*, Vol. 52, pp. 4205 - 4210, 2007.

Gregory, A.P., and Clarke, R.N., "Dielectric Metrology with Coaxial Sensors", *Measurement Science and Technology*, Vol. 18, No. 5, pp. 1372 -1386, 2007.

Greiner, Thomas M., *Hand Anthropometry of US Army Personal*, Army Natick Research Development and Engineering Center, Technical Report Natick/TR-92/011, Dec. 1991.

IEEE P1528.1™/D1.0 Draft *Recommended Practice for Determining the Peak Spatial-Average Specific Absorption Rate (SAR) in the Human Body from Wireless Communications Devices, 30 MHz - 6 GHz: General Requirements for using the Finite Difference Time Domain (FDTD) Method for SAR Calculations.*

IEEE P1528.3™/D2.0 Draft *Recommended Practice for Determining the Peak Spatial-Average Specific Absorption Rate (SAR) in the Human Body from Wireless Communications Devices, 30 MHz - 6 GHz: General Requirements for using the Finite Difference Time Domain (FDTD) Modeling of Mobile Phones/ Personal Wireless Devices.*

IEEE P1528.4™/D1.0 Draft *Recommended Practice for Determining the Peak Spatial Average Specific Absorption Rate (SAR) in the Human Body from Wireless Communications Devices, 30 MHz - 6 GHz: Requirements for Using the Finite-Element Method for SAR Calculations*, specifically involving Vehicle-Mounted Antennas and Personal Wireless Devices.

IEEE Recommended Practice for Determining the Peak Spatial-Average Specific Absorption Rate (SAR) in the Human Head from Wireless Communications Devices: Measurement Technique, IEEE, Inc., December 19, 2003.

IEEE, 1528™ SCC34 Draft Standard: *Recommended Practice for Determining the Peak Spatial-Average Specific Absorption Rate (SAR) in the Human Body Due to Wireless Communications Devices: Experimental Techniques*, April 2002.

International Organization for Standardization, *Guide to the Expression of Uncertainty in Measurement*, Geneva, Switzerland, 1995.

ISO/IEC 17025:2005: General requirements for the competence of testing and calibration laboratories.

Li C-H., Ofli E., Chavannes N., and Kuster N., "The Effects of Hand Phantom on Mobile Phone Antenna OTA Performance", *Proc. Second European Conference on Antennas and Propagation*, EuCAP 2007, Edinburgh, UK, November 11 - 16, 2007.

NIS 81, "*The Treatment of Uncertainty in EMC Measurements*," Ed. 1, NAMAS Executive, National Physical Laboratory, Teddington, Middlesex, TW11 0LW, England, 1994.

NIST, "*Guidelines for evaluating and expressing the uncertainty of NIST measurement results*", Technical Note 1297 (TN 1297), United States Department of Commerce Technology Administration, National Institute of Standards and Technology, Gaithersburg, MD, 1994.

Ofli E., Chavannes N., and Kuster N., "The Uncertainties and Repeatability Limitations of Transmitter and Receiver Performance Assessments Posed by Head Phantoms", *Proc. IEEE International Workshop on Antenna Technology (IWAT06)*, New York, pp. 349-352, 2006.

OMA-AD-SUPL-V2_0-20110527-C, Candidate Version 2.0 (27 May 2011): Secure User Plane Location Architecture.

TIA-866-1[E]: Recommended Minimum Performance Standards for cdma2000® High Rate Packet Data Access Terminal - Addendum 1, January 2004.

TIA-866-A: Recommended Minimum Performance Standards for cdma2000® High Rate Packet Data Access Terminal, January 2006.

TIA-916: Recommended Minimum Performance Specification for TIA/EIA/IS-801-1 Spread Spectrum Mobile Station, April 2002.

TIA-98-E: Recommended Minimum Performance Standards for cdma2000 Spread Spectrum Mobile Stations, June 2001.

1.4 Test Overview

This test plan presents the individual test procedures organized by type of test (Transmitter, Receiver) and/or technology (CDMA, GSM, etc.).

The testing requirements fall into 3 categories:

1. Measuring the basic performance of the test chamber,
2. Measuring the path loss of the test system, and
3. Measuring the performance of the wireless device.

The basic performance of the test chamber is covered in [Section 3](#), and includes a site validation method used to determine the uncertainty contribution of the test system. Corrections for the path loss of the test system, including range length, measurement antenna, cables, amplifiers, etc. are determined using the range reference measurement described in [Section 4](#). This measurement uses a calibrated reference antenna to determine a relative correction value that can then be applied to measurement instrument readings in order to determine the performance of the wireless device relative to a theoretical isotropic radiator or receiver. The measurement of the wireless device is covered in [Section 5](#) for radiated power measurements and [Section 6](#) for sensitivity measurements. On completion of the three measurement categories, the results are processed as described in [Appendix B](#). The overall measurement uncertainty is calculated in the manner described in [Section 7](#) (using [Appendix G](#) as a guide).

The test report requirements are defined in [Appendix B](#).

1.5 Equipment Under Test (EUT) and Accessories—The Wireless Device

All samples submitted to a ATL for radiated performance testing shall be representative of typical production units and will be able to comply with the regulatory requirements of the countries in which the device is targeted to be sold. At the manufacturer's discretion, one or multiple samples may be submitted. All samples must be provided to a single ATL responsible for OTA testing of the device, known as the "primary" ATL. The primary ATL may distribute the device sample(s) to labs acting as a subcontractor to the primary ATL.

The primary ATL and its subcontractors shall ensure that all of the requirements listed below are met:

- All sample devices must be capable of supporting all applicable radiated performance test cases.
- If conducted measurements are required to be made for a given protocol, they shall be performed on the sample and documented for each sample for each of the test frequencies, bands, and protocols utilized.
- When multiple samples are provided, the EUT shall be randomly selected from among the submitted samples such that a single EUT will be employed for tests within a:
 - Cellular Radio Mode
 - Band
 - Test Type (e.g., A-GNSS, TRP, or TIS)
 - Test Condition (e.g., FS, BHHL or BHHR)

Example: If a manufacturer provides four sample devices to the ATL (Device A, B, C and D) and the lab randomly selects Device C for execution of BHHR testing for TIS in UMTS Band II, then all radiated performance tests associated with this test condition, test type, band and cellular radio mode must be executed with Device C only. In this example,

- BHHL testing for TIS in UMTS Band II could be executed with a different randomly-selected sample device. BHRH testing for TIS in UMTS Band V could be executed using yet another randomly-selected sample device, etc.
- The test report must unambiguously state which sample and test system was used for each test condition in order to comply with the traceability requirements of ISO/IEC 17025:2005.
 - One or more authorized test systems may be utilized.
 - For testing that employ relative measurements, such as single point offset test (SPOT) for CA, a different chamber and sample may be used regardless of which was used for the original test. Both the Test Configuration A and Test Configuration B tests which make up the SPOT shall be performed in the same OTA chamber using the peak position and polarization from the original (full) radiated test, regardless of which chamber it was performed in. The delta between Test Configuration A and Test Configuration B shall be applied to the original (full) radiated test as specified in Sections 5.11.1, 5.11.2, 6.15.1 and 6.15.2. If the laboratory chooses to utilize this option, the measurement uncertainty for the alternate procedure shall be updated to reflect any differences in chamber equipment or setup.

Units for test are to be supplied with all required peripherals and accessories, including the standard battery and charger as supplied with the unit. For protocols requiring conducted measurements and an RF port is available on the EUT, a calibrated RF adapter cable terminating in a common SMA or “type N” connector shall be supplied for conducted measurements. The associated RF insertion loss for that cable connection shall be included.

The sample devices for A-GNSS OTA for LTE shall be prepared by the manufacturer to ensure compatibility with the test procedure herein which utilizes the Open Mobile Alliance (OMA) Secure User Plane (SUPL) 2.0 protocol. Specifically, the manufacturer shall:

- Install the SUPL certificate(s) for the corresponding LTE A-GNSS test equipment used at the “primary” ATL and at any labs acting as a subcontractor to the primary ATL. Ideally, the manufacturer should install the SUPL certificates for all LTE A-GNSS test equipment manufacturers referenced on the authorized equipment list.
- Provide a mechanism (application, hidden menu, support tool, etc.) that allows the ATL to specify the SUPL server address and port or have this information pre-set on the device for the corresponding LTE A-GNSS test equipment used at the “primary” ATL and at any labs acting as a subcontractor to the primary ATL.

Alternatively, the manufacturer shall provide tools and detailed instructions that allow the CATLs to install the SUPL certificates and set the SUPL server and ports themselves on any of the provided sample devices for A-GNSS OTA for LTE.

1.6 Wireless Device Documentation

All documentation and accessories associated with the installation and operation of the EUT shall be supplied. This includes, at a minimum:

- User guides or manuals
- Programming instructions
- Installation guides or manuals
- Service manuals, including manual control of EUT from Test Interface Unit and/or keypad
- All Base Station Simulator settings required to register the EUT and establish a call

- Manufacturer declaration of primary mechanical mode of operation, i.e., portrait slide open, fold open, or other mechanical configuration
- Diagram of all antennas tested using this test plan as supplied by the manufacturer:
 - Each antenna shall be labelled with a letter, starting with the letter “A”
 - Each unique antenna feed shall be associated with a unique label
 - These labels shall be used by the ATL when completing the reporting tables in [Appendix B.1](#).
- Table B-2 as completed by the manufacturer:
 - Declaration of all bands and protocols supported by each antenna, and to which transceiver functions the antenna are connected (transmitter, primary receiver, secondary receiver)
 - Declaration of all antenna, band and protocol combinations that are activated dynamically for RX functionality
 - Declaration of which antennas are dynamically tuned in such a way that offset - tests (Section 5.11.1, Section 5.11.2, Section 6.15.1 and Section 6.15.2 cannot be used when offset tests are being considered for use.)
 - Declaration of the baseline antenna receiver combination (switch state) to be used as a baseline for testing devices supporting RX antenna switching (Section 6.19). Declaration of which switch states require testing according to Section 6.19.
- Instructions for enabling testing of devices supporting antenna switching (see Section 5.14 and Section 6.19.)
- Instructions for which channel(s) to test A-GNSS with LTE Band 12 (see Section 6.13.5.4.1)
- Manufacturer to report the targeted operators in order for LTE CA testing to be determined according to the operator CA priority list (see [Appendix O.8](#))
- For wrist-worn devices:
 - Declaration of the wristband to be used during the testing. The wristband to be used shall be the wristband packaged with the end product. If wristbands are provided separately, the wristband selection shall be based on the expected worst-case wristband.
 - Declaration of the housing material to be used during the test based on the expected worst-case material.
 - Declaration of the single arm orientation (WL or WR) to be used for test, based on the expected worst-case orientation and based on input from target operators.

In addition to the documentation, the manufacturer shall provide contact information including telephone number and e-mail address of an individual responsible for providing technical and operational assistance.

Section 2 Scope of Measurements

Good radiated performance is critical to the effective operation of a wireless device in today's networks. As devices become smaller, radiated performance can often become compromised. For example, achieving an efficient antenna in a small size and over multiple frequency bands is a difficult task. A comprehensive and accurate characterization of radiated performance will enable carriers and manufacturers to determine how well wireless devices will work within the constraints of a specific cellular network design.

Generally, peak EIRP (Effective Isotropic Radiated Power) is not a good indication of wireless performance in the field. For example, if the radiation pattern of the EUT's antenna system is highly directive, the peak EIRP would be high (since the antenna gain is high in one direction), but coverage would be poor in other directions. In a cellular environment it is best to maximize the spatial coverage of the antenna system so that the user does not have to point the antenna in one particular direction to get good call performance. Further, the human head and/or hand can alter the shape and peak value of the EUT radiation pattern. Losses due to the head and/or hand can vary significantly with frequency, device size, and antenna design implemented. From a field performance perspective, measurement of the average EIRP on a head and/or hand model is more meaningful than measurement of peak EIRP in free-space conditions. This test plan requires average spherical effective isotropic radiated power (termed Total Radiated Power, TRP) to be measured.

Receiver performance, or EIS (Effective Isotropic Sensitivity) is as important to the overall system performance as transmitter performance. The downlink receive path is integral to the quality of the device's operation. Poor receiver radiated performance will cause the user of the subscriber unit to hear a low quality voice signal. This can also cause the subscriber unit to lose the base station signal resulting in abrupt termination of the call. This test plan requires average spherical effective radiated receiver sensitivity (termed, in the general sense, Total Isotropic Sensitivity, TIS) to be measured. A frequent cause of poor sensitivity on a single channel, or a small number of channels, is due to receiver in-band noise, or spurious signals from the transmitter itself being radiated back into the receiver. The receiver sensitivity will be measured with the transmitter set to the maximum power output allowed by the particular EUT and technology combination.

The procedures defined herein will a) evaluate the inherent performance of the test chamber used for the measurements; b) detail the measurements of the transmitter performance (as TRP) and receiver performance (as TIS) for the wireless device (measuring wireless performance in free-space and/or with phantoms where appropriate); c) detail the method for calculation of the associated measurement uncertainty.

2.1 Equipment Under Test (EUT) Measurements—Transmitter

The radiated RF performance of the Equipment Under Test (EUT) is measured by sampling the radiated transmit power of the mobile at various locations surrounding the device. A three-dimensional characterization of the 'transmit' performance of the EUT is pieced together by analyzing the data from the spatially distributed measurements. Data points taken every 15 degrees in the theta (θ) and in the phi (ϕ) axes are deemed sufficient to fully characterize the EUT's Far-Field radiation pattern and total radiated power. This accounts for a total of 264 measurements for each of two orthogonal polarizations since measurements at theta = 0 and 180 degrees are not required. All of the measured power values will be integrated to give a single figure of merit referred to as Total Radiated Power (TRP).

2.2 Equipment Under Test (EUT) Measurements—Receiver

The receiver performance of the Equipment Under Test (EUT) is measured utilizing Bit Error Rate (BER), Frame Error Rate (FER), or other error criteria. This test specification uses the appropriate error criteria to evaluate effective radiated receiver sensitivity at each spatial measurement location. A three-dimensional characterization of the receiver performance of the EUT is pieced together by analyzing the data from the spatially distributed measurements. Data points taken every 30 degrees in the theta (θ) and in the phi (ϕ) axes are deemed sufficient to fully characterize the EUT's total isotropic sensitivity. This accounts for a total of 60 measurements for each of two orthogonal polarizations since measurements at theta = 0 and 180 degrees are not required. All of the measured sensitivity values for each EUT test condition will be integrated to give a single figure of merit referred to as Total Isotropic Sensitivity (TIS).

Some digital technologies and/or EUTs may not allow the measurement of error criteria without special procedures for controlling the EUT. In this case, external cables and manual test commands may be applied to the EUT for setup purposes only. All such cables must be removed and the EUT operated in stand-alone battery powered mode during the data collection process.

2.3 Equipment Under Test (EUT) Measurements—General

Two acceptable methods of scanning the EUT are proposed. (1) The “conical” cut method, whereby the EUT rotates on its long axis and the Measurement Antenna is moved (either mechanically in the case of systems using a single Measurement Antenna or electrically for those systems using multiple measurement antennas) to several locations both above and below the level of the EUT for each rotation. (2) The “great circle” cut method, whereby the Measurement Antenna remains fixed and the EUT is rotated about two axes in sequential order. [Section 2.4](#) describes the Conical Cut Test Method; [Section 2.5](#) describes the Great Circle Cut Method. The test configurations detailed in [Appendix A](#) are suggested testing methods; alternative positioning methods that yield data samples at the specified angular locations with similar polarization properties are acceptable. Alternately, data point reduction methods that reduce the measured data points near theta = 0° and theta = 180° while maintaining the effective surface resolution required for a given test may be used, although additional uncertainty contributions may be required.

In both Conical Cut and Great Circle Cut methods, the angle of elevation in the long axis of the EUT is referred to as the theta angle, and the azimuth angle of the EUT is referred to as the phi angle. The axis of turntable rotation will measure along the theta axis for the Great Circle Cut method, and along the phi axis for the Conical Cut method. Although the data is gathered in a different order, the resultant data from both methods is measured at the same (θ , ϕ) points and is processed in the same manner. The Measurement Antenna should be capable of measuring in two orthogonal linear polarizations, E-phi and E-theta. These two polarizations may be measured during a single EUT rotation or during subsequent rotations.

The overall measurement of the EUT makes use of the data obtained from [Section 4](#) to normalize the measured performance of the EUT performed over a spherical surface with the EUT's antenna centered in the sphere. A Base Station Simulator is used to set up calls to the EUT and to request reports of signal strength that the EUT is measuring on the 'receive' frequency of the call. These two measurements may be taken individually or together as part of a single set of sampling scans. Data is collected and stored during the measurement step for delivery with the test report for each device tested.

Depending on the type of device being tested, measurements will be made in the following configurations:

1. A “free-space” configuration, whereby the EUT will be placed directly on a support made of low dielectric material
2. A “head and hand phantom” configuration, whereby the EUT will be placed in a hand phantom, against a head phantom,
3. A “hand phantom only” configuration, whereby the EUT will be placed in a hand phantom.

Coordinate systems and positioning requirements for all configurations are described in [Appendix A](#). The requirements for the head and hand phantoms are defined in [Appendix C](#).

Measurements will be performed with the antenna of the EUT extended and retracted (if applicable) in the test configurations.

Different measurement results may be obtained between positioning the EUT on the left or right ear of the head phantom. As a result, this Test Plan requires the measurement of performance against both ears for the head and hand phantom tests. In the interest of managing the overall test time, head phantom only tests are no longer required.

Measurement variability may also be attributed to the level of fluid in the head phantom; especially when the head phantom is positioned horizontally (Great Circle Cut). To minimize measurement uncertainties, air bubbles in the head phantom should be eliminated by completely filling the head phantom with fluid. Special care should be taken when performing Great Circle Cut measurements on the head phantom to ensure the center of rotation is about the volume center of the EUT for free space measurements, about the Ear Reference Point (see [Appendix C.2](#)) for head phantom testing and head and hand phantom testing, and about the EUT’s display center for hand phantom testing.

Tests shall be performed on all possible EUT configurations (i.e., battery pack configurations, housing schemes) unless it is demonstrated that there is negligible impact to performance with the different options. It is the responsibility of the manufacturer to define which options represent the “baseline” configuration and to provide adequate supporting data that validates assumptions for reduced testing of the remaining options. At a minimum, a complete set of measurements is required for the baseline EUT configuration.

2.4 Conical Cut Test Method

[Figure A-26](#) in Appendix A shows a diagram of the Conical Cut measurement method. The Conical Cut method requires the ability of the Measurement Antenna to be physically rotated in the theta plane (overhead) of the EUT for implementations using a single Measurement Antenna. For systems using multiple measurement antennas, the rotation in the theta plane is achieved by electrical selection of the different antennas. Eleven conical cuts are required to capture data at every 15 degrees from the EUT, whereas only five are required to capture data at 30-degree intervals; with the top (0 degrees) and bottom (180 degrees) cuts not being measured. Typically, the EUT will remain affixed to a turntable during the entire measurement process. The Measurement Antenna will be positioned at a starting theta angle. The EUT will then be rotated around the full 360 degrees of phi rotation. The Measurement Antenna will then be positioned at the next theta angle, and the process repeated.

Measurements of the radiated transmit power and receiver sensitivity should be recorded in both E-theta and E-phi polarizations simultaneously to reduce measurement uncertainties due to EUT repositioning. The EUT will report the power it measures in the receive-band by sending a message to the Base Station Simulator (for technologies that support this function).

2.5 Great Circle Test Method

The ear centered head phantom configuration shown in [Appendix A](#) is used in [Figure 2-1](#) to illustrate the pattern cuts that are taken with a Great Circle Cut system. The coordinate system shall be oriented such that the Z-axis for a given configuration is along the horizontal axis. The pattern cuts are theta rotation cuts. The vertical discs illustrate the 30 degree points on the rotation lines (which are orthogonal to the discs). A measurement is carried out at every intersection of these vertical discs and the rotation lines (except at the poles where $\theta = 0$ and 180 degrees). Note that the illustration is for the 30 degree grid points involved in the TIS measurement only. For the TRP tests, the grid of measurement points is much more dense since the grid points are spaced by 15 degrees.

[Figure 2-1](#) shows a cluster of measurement points towards the poles. It is due to this clustering that the measurement data has to be 'weighted' by $\sin(\theta)$ so that the requirement for uniform density of measurement points around the sphere is achieved. As a consequence, it is pointless measuring at θ angles of 0 and 180 degrees since these calculate out to zero.

With the Z-axis of the coordinate system horizontal and rolling in the elevation plane, the Great Circle Cut test method will measure exactly the same (θ , ϕ) points as those measured by Conical Cut systems.

For TIS tests, 6 Great Circle Cuts need to be made to completely measure the 3D sphere. These are referred to as T0, T30, T60, T90, T120, and T150 where T0 is the initial cut and is defined as the cut for which the horizontal head has the test ear closest to the ground. [Figure 2-2](#) illustrates the T0 cut. For TRP tests, T0 should be the same cut, but given that the grid is 15 degrees; the series of cuts becomes T0, T15, T30, T45, T60, T75, T90, T105, T120, T135, T150 and T165. The composite of these θ cuts provides a three-dimensional view of the antenna pattern and performance.

The T0 cut as shown in [Figure 2-2](#) has been deliberately chosen so that the measurement will not include the cut with the test ear uppermost, since this cut could potentially give corrupted results should an air bubble have formed within the head. None of the cuts T0 to T150 or T165 will be influenced by the presence of an air bubble, provided a regular maintenance procedure for checking (and refilling if necessary) the head phantom is in place and a hard limit on the size of the air bubble is imposed. It is suggested that weekly checks should be made on the state of the liquid and that any air bubble that has collected should not be allowed to exceed 25 mm in diameter when measured against a flat plate. Tests performed with bubbles as large as 100 mm in diameter indicate that several tenths of a dB error can be expected due to the bubble when near the phone. The magnitude of the effects in these tests indicates that a suitably small bubble near the phone will have a negligible effect on the measured results. For the purposes of this test plan, a bubble size less than 13 mm in diameter can be assumed to have a negligible effect, even when near the phone. As long as this requirement is met, both the great circle or conical cut methodology may be used on a head phantom with orientations other than vertical.

Wherever possible, measurements of the radiated transmit power and receiver sensitivity should be recorded in both E- θ and E- ϕ polarizations simultaneously to reduce measurement uncertainties due to EUT repositioning. The EUT will report the error criteria or the measurements needed to calculate the error criteria that it measures in the receive-band by sending a message to the Base Station Simulator (for technologies that support this function).

[Figure 2-1](#) illustrates the measurement configuration for the Great Circle cut method.

FIGURE 2-1 GREAT CIRCLE CUTS AND MEASUREMENT POINTS (FOR 30 DEGREE GRID)

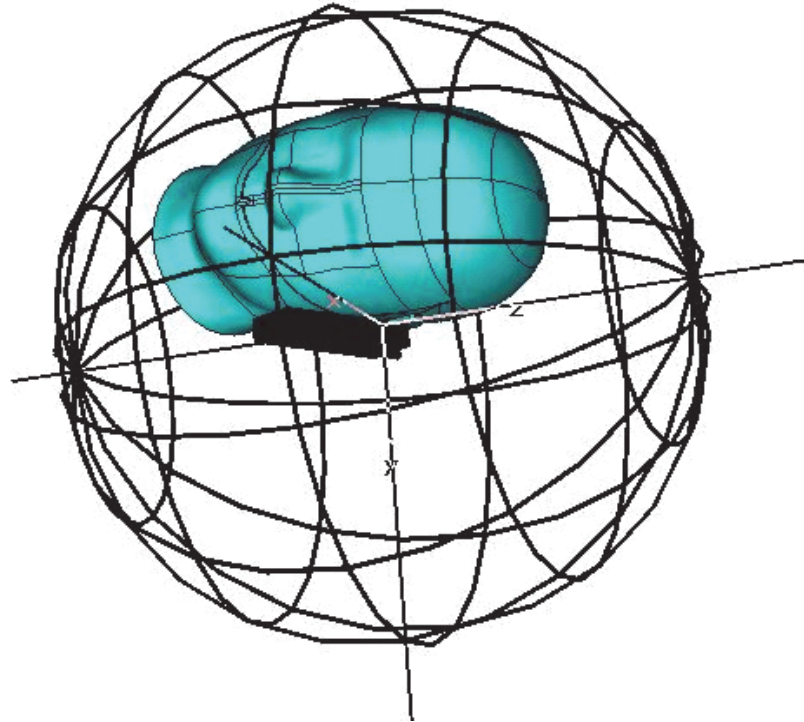
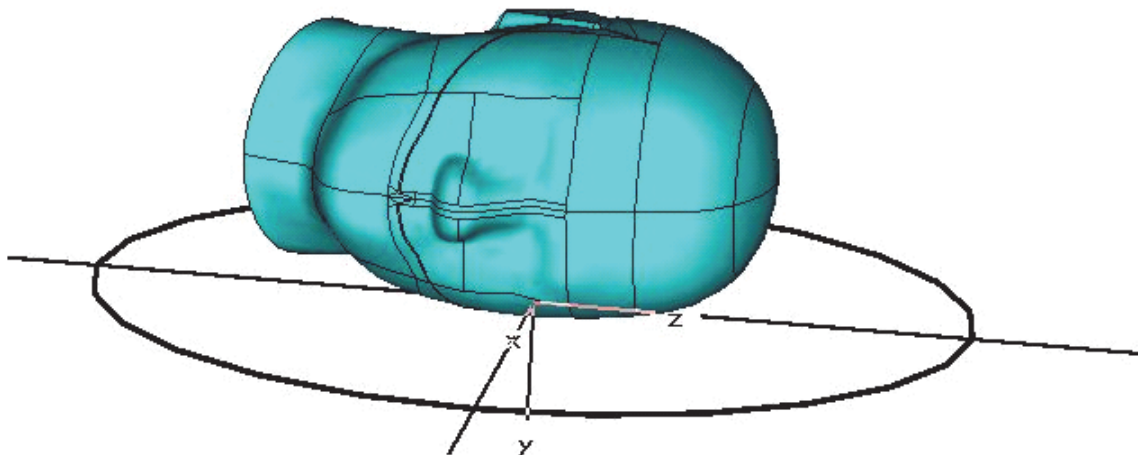

FIGURE 2-2 THE GREAT CIRCLE T0 CUT



2.6 Theta Dependent Phi Step Size Optimization

An optional data point reduction optimization can be used for measurements performed using a conical cut acquisition process in order to improve test time by as much as 25-35%. In this case, the ϕ angle step size can be varied as a function of the θ position according to the formula:

$$N_{\phi}(\theta) = 1 + \text{int}((N_{\phi}(90^{\circ}) - 1) \sin(\theta))$$

where $N_{\phi}(\theta)$ is the minimum number of points at any given θ position, $N_{\phi}(90^{\circ})$ is defined as 360° divided by the chosen ϕ angle step size, and $\text{int}()$ refers to taking the integer portion of the result within the parentheses. The ϕ angle step size for this θ angle is then given by $360^{\circ}/N_{\phi}(\theta)$. The target positions may be rounded to the nearest whole degree if desired. It is also allowable to increase the number of steps for any given θ angle over the minimum defined above in order to align the angular ϕ positions to even positions for one or more ϕ cut(s), allowing the optimization to be used for great circle cuts as well.

Section 3 Test Site Characteristics and Quiet Zone Accuracy

This section describes the required procedure for ensuring sufficient quiet zone performance of the test site. This procedure is required to characterize variations in field measurements caused by reflections within an anechoic chamber. This test is designed to characterize the entire test system, including any positioners and support structure.

The test procedure measures the azimuth plane pattern cuts of highly symmetrical dipoles and loops for a number of positions and orientations within the desired quiet zone. The deviation of these pattern cuts from a perfect circle (the ripple) is then used to determine the resulting measurement uncertainty through a statistical analysis. Since the symmetry of the probe antennas is critical, a procedure for verifying its symmetry is also provided.

3.1 Minimum Measurement Distance

This section describes the minimum measurement distance, R , which the Far-Field test site shall provide. The measurement distance is defined as the distance from the center of rotation of the EUT to the phase center (alternatively, if not accurately known, the nearest point) of the Measurement Antenna. The minimum measurement distance is specified in [Table 3-1](#), below.

TABLE 3-1 MINIMUM MEASUREMENT DISTANCE FOR HANDHELD EUTs

Band	Lower Frequency (MHz)	Upper Frequency (MHz)	Minimum Measurement Distance <i>R</i> (meters)
3GPP Band 71	617	698	1.46
3GPP Band 12	699	746	1.29
3GPP Band 17	704	746	1.28
3GPP Band 29	717	728	1.26
3GPP Band 13	746	787	1.21
3GPP Band 14	758	798	1.19
3GPP Band 26	814	894	1.11
Cellular (3GPP Band 5)	824	894	1.09
MBS (M-LMS Band)	919.75	927.25	0.98
GNSS	1574	1606	0.96
3GPP Band 70 TX	1695	1710	1.03
AWS-1 TX (3GPP Band 4 TX)	1710	1755	1.05
3GPP Band 66 TX	1710	1780	1.07
PCS (3GPP Band 2)	1850	1990	1.19
3GPP Band 25	1850	1995	1.20
3GPP Band 70 RX	1995	2020	1.21
AWS-1 RX (3GPP Band 4 RX)	2110	2155	1.29
3GPP Band 66 RX	2110	2200	1.32
3GPP Band 30	2305	2360	1.42
3GPP Band 7	2500	2690	1.61
3GPP Band 41	2496	2690	1.61
3GPP Band 48	3550	3700	2.22
3GPP Band 46	5150	5925	3.56

A test site shall provide at least the specified minimum measurement distance for all tests and validation procedures described in this test plan. Alternatively, a minimum measurement distance of 1.2 m may be used, provided the appropriate uncertainty term is included in the uncertainty budget for the test case. This uncertainty term may be taken from [Table G-6](#). Note that this uncertainty term is in addition to the uncertainty term in [Table G-1](#). This uncertainty term from [Table G-6](#) shall only be applied once for small (< 30 cm) or large (< 42 cm) form factor devices. It is understood that the uncertainty terms in [Table G-6](#) are based on the large form factor, and as such, represent the worst case uncertainty expected.

These distances derived in the table above are the minimum recommended to facilitate measurement in the Far-Field for the purposes of this test plan. They are based on selecting the strictest of the three conventional Far-Field criteria within each band. These criteria express that the measurement distance be greater than the largest of $2D^2/\lambda$ (the phase uncertainty limit), $3D$ (the amplitude uncertainty limit), and 3λ (the reactive Near-Field limit), where D is the dimension of the radiator and λ is the free-space wavelength at the frequency band of interest. For a free space test, D would simply be the largest dimension of the EUT, but some portion of the head/hand phantom must be included in D for head/hand

phantom tests. For purposes of this test plan, D is selected to be the dimension of that part of the head/hand phantom that participates significantly in determining the TRP or TIS of the EUT, and is chosen as 300 mm. The details of the calculations are given for informational purposes only.

TABLE 3-2 DERIVATION OF MINIMUM MEASUREMENT DISTANCE FOR HANDHELD EUTS (INFORMATIVE ONLY)

Band	Lower Frequency (MHz)	Upper Frequency (MHz)	λ_L (m)	λ_U (m)	$R > \frac{2D^2}{\lambda_U}$ (m)	$R > 3D$ (m)	$R > 3\lambda_L$ (m)	Strictest Criterion (m)
3GPP Band 71	617	698	0.49	0.43	0.42	0.90	1.46	1.46
3GPP Band 12	699	746	0.43	0.40	0.45	0.90	1.29	1.29
3GPP Band 17	704	746	0.43	0.40	0.45	0.90	1.28	1.28
3GPP Band 29	717	728	0.42	0.41	0.44	0.90	1.26	1.26
3GPP Band 13	746	787	0.40	0.38	0.47	0.90	1.21	1.21
3GPP Band 14	758	798	0.40	0.38	0.48	0.90	1.19	1.19
Cellular 3GPP Band 26	814	894	0.37	0.34	0.54	0.90	1.11	1.11
Cellular (3GPP Band 5)	824	894	0.36	0.34	0.54	0.90	1.09	1.09
MBS (M-LMS Band)	919.75	927.25	0.33	0.32	0.56	0.90	0.98	0.98
GNSS	1574	1606	0.19	0.19	0.96	0.90	0.57	0.96
3GPP Band 70 TX	1695	1710	0.18	0.18	1.03	0.90	0.53	1.03
AWS-1 TX (3GPP Band 4 TX)	1710	1755	0.18	0.17	1.05	0.90	0.53	1.05
3GPP Band 66 TX	1710	1780	0.18	0.17	1.07	0.90	0.53	1.07
PCS (3GPP Band 2)	1850	1990	0.16	0.15	1.19	0.90	0.49	1.19
3GPP Band 25	1850	1995	0.16	0.15	1.20	0.90	0.49	1.20
3GPP Band 70 RX	1995	2020	0.15	0.15	1.21	0.90	0.45	1.21
AWS-1 RX (3GPP Band 4 RX)	2110	2155	0.14	0.14	1.29	0.90	0.43	1.29
3GPP Band 66 RX	2110	2200	0.14	0.14	1.32	0.90	0.43	1.32
3GPP Band 30	2305	2360	0.13	0.13	1.42	0.90	0.39	1.42
3GPP Band 7	2500	2690	0.12	0.11	1.61	0.90	0.36	1.61

TABLE 3-2 DERIVATION OF MINIMUM MEASUREMENT DISTANCE FOR HANDHELD EUTs (INFORMATIVE ONLY)

Band	Lower Frequency (MHz)	Upper Frequency (MHz)	λ_L (m)	λ_U (m)	$R > \frac{2D^2}{\lambda_U}$ (m)	$R > 3D$ (m)	$R > 3\lambda_L$ (m)	Strictest Criterion (m)
3GPP Band 41	2496	2690	0.12	0.11	1.61	0.90	0.36	1.61
3GPP Band 48	3550	3700	0.08	0.08	2.22	0.90	0.25	2.22
3GPP Band 46	5150	5925	0.06	0.05	3.56	0.90	0.17	3.56

Future additions of new frequency bands will follow the same Far-Field criteria derivation. It is understood that Near-Field measurement techniques can permit an accurate measurement to be performed at distances smaller than those specified here, with proper mathematical manipulation of the raw amplitude and phase data. Such systems may be considered by CTIA Certification for inclusion in this test plan when they have been demonstrated for TRP and TIS measurements for the relevant modulation methods.

3.2 Equipment Required

Details on the symmetry antenna can be found in [Appendix F](#).

1. Anechoic chamber and spherical positioning system to be characterized. For the purpose of these tests, this chamber must be large enough to allow the Measurement Antenna (MA) to be at least R (the minimum measurement distance specified in [Table 3-1](#) for the frequency band being tested) from center of rotation of the EUT and the test site must be reasonably free of interference. This method is intended to characterize the effect of a variety of positioning systems on the required pattern tests. However, reasonable precautions should be taken to avoid designs that would reflect significant radiated energy back into the test region or absorb significant energy out of the test region. Such systems may cause significant error in the measurement results and defeat the purpose of this test.
2. Sleeve dipole probe antennas with less than ± 0.1 dB of asymmetry¹ in the azimuth plane pattern for each frequency called out in [Section 3.3](#).
3. Loop probe antennas with less than ± 0.1 dB of asymmetry² in the azimuth plane pattern for each frequency called out in [Section 3.3](#).

Note: It is necessary that the above antennas be optimized for the respective frequencies as indicated in [Section 3.3](#).

4. Low dielectric constant support structure (e.g. Styrofoam) for positioning the probe antennas
5. Measurement antenna(s) (e.g., horn or dipole used during antenna measurements)
6. Network analyzer or signal generator/measurement receiver.

1. The asymmetry specification for purposes of this measurement may be stated more specifically as the pattern shall not deviate from a perfect circle by more than 0.1 dB (0.2 dB peak-to-peak). Sleeve dipoles and center fed balanced loop antennas are recommended since the cable and feed point may be arranged in such a way that interactions with the measurement are minimized. The asymmetry specification holds only at the frequency at which the ripple test is performed (see [Table 3-3](#)). The gain and efficiency of this antenna is immaterial since the measurement seeks to determine deviations in the measured antenna pattern caused by reflections within the measurement chamber.

3.3 Test Frequencies

Frequencies to be used to test for quiet zone accuracy:

TABLE 3-3 QUIET ZONE ACCURACY FREQUENCIES

Band	Test Frequency (MHz)
LTE 600 MHz (3GPP Bands 71) ¹	617 ± 1 MHz
LTE 700 MHz (3GPP Bands 12, 17, 29, 13, 14) ¹	722 ± 1 MHz
Cellular (3GPP Band 5 and 26), and MBS ¹	836.5 ± 1 MHz
GNSS (GPS L1 and GLONASS) ¹	1575.42 ± 1 MHz
AWS-1 TX (3GPP Band 4 TX, 3GPP Band 70 TX, 3GPP Band 66 TX)	1732.5 ± 1 MHz
PCS (3GPP Band 2 and 3GPP Band 25 and 3GPP Band 70 RX) ¹	1880 ± 1 MHz
AWS-1 RX (3GPP Band 4 RX and 3GPP Band 66 RX)	2132.5 ± 1 MHz
Bands in the range 2300-2800 MHz (3GPP Bands 7, 30, 41) ¹	2450 ± 1 MHz
Bands in the range 3300-3800 MHz (3GPP Band 48) ¹	3600 ± 1 MHz
Bands in the range 5000-6000 MHz (3GPP Band 46) ¹	5500 ± 1 MHz
Note 1: Note that the test frequencies have been chosen to optimize the quiet zone test requirements.	

3.4 Terminology and Coordinate Systems

This test procedure has been designed to be as generic as practical in order to produce similar results for any test system. The principal goal is to qualify the behavior of the quiet zone from as many orientations as practical.

Starting from the classical spherical coordinate system shown in [Figure 3-1\(a\)](#), the phi (ϕ) axis is defined as being along the Z-axis. Treating this as the coordinate system of the EUT is the equivalent of assuming the EUT is mounted directly to the phi-axis rotator. Then as the phi axis rotates, the orientation of the theta axis varies with respect to the EUT (see [Figure 3-1b](#)).

FIGURE 3-1 SPHERICAL COORDINATE SYSTEM

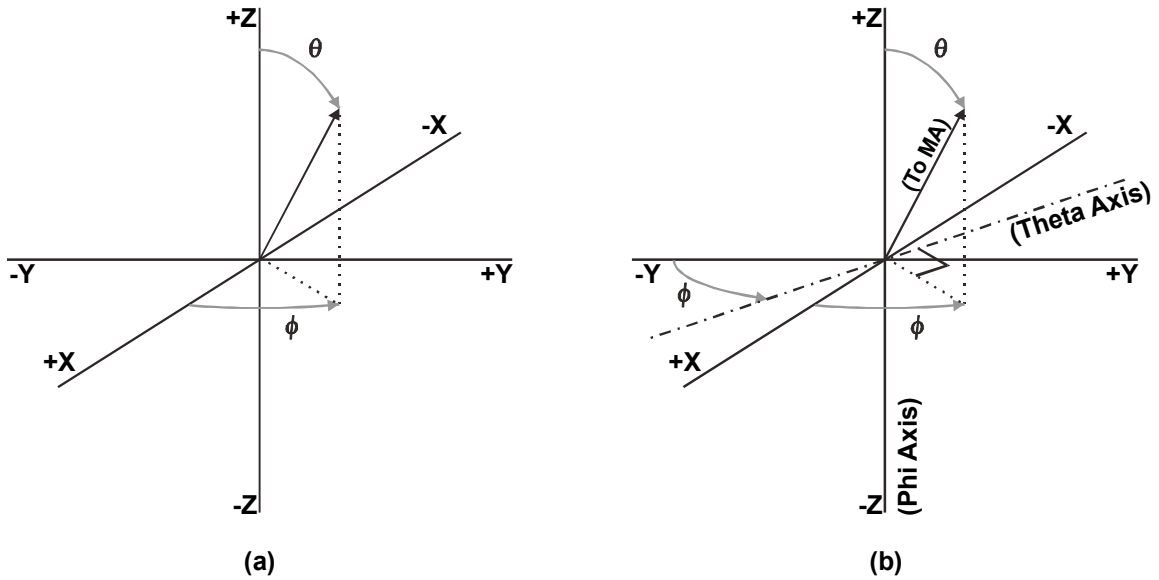

In conjunction with defining the spherical coordinate system, it is necessary to define the two polarizations to be used for measuring total field at each point. The polarizations are identified in terms of the two rotational axes, such that the phi polarization is along the direction of motion when the phi axis rotates and the theta polarization is along the direction of motion when the theta axis rotates (see [Figure 3-2](#)).

FIGURE 3-2 MEASUREMENT ANTENNA POLARIZATIONS

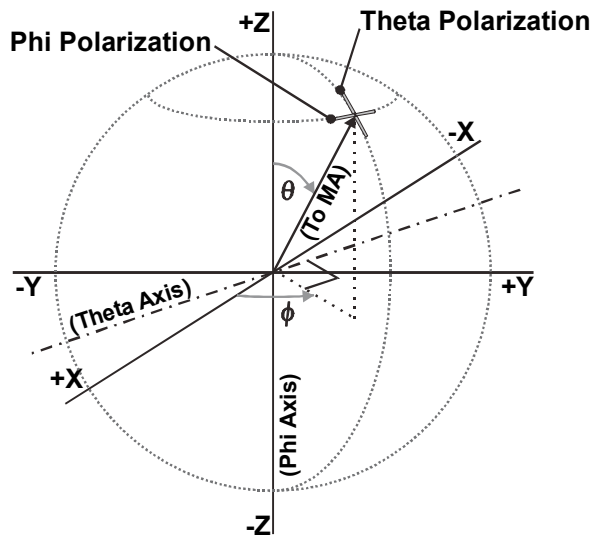

The test plan assumes that the EUT will be supported by some sort of structure along the $-Z$ -axis, which is likely to obstruct or obscure the measurement of the data point at the $\theta = 180^\circ$ point. The resulting spherical coverage required for a pattern test (based on 15 degree steps) is given in Figure 3-3, which shows that the whole 3D surface is included in the testing, with the exception of the area for which $|\theta| > 165$. The ripple test is intended to cover the same range of angles for each axis as are required to perform a pattern measurement. Thus, the theta-axis ripple test only extends to $\theta = 165^\circ$.

FIGURE 3-3 SPHERICAL COVERAGE AND ORIENTATION OF SUPPORT STRUCTURE WITH RESPECT TO COORDINATE SYSTEM

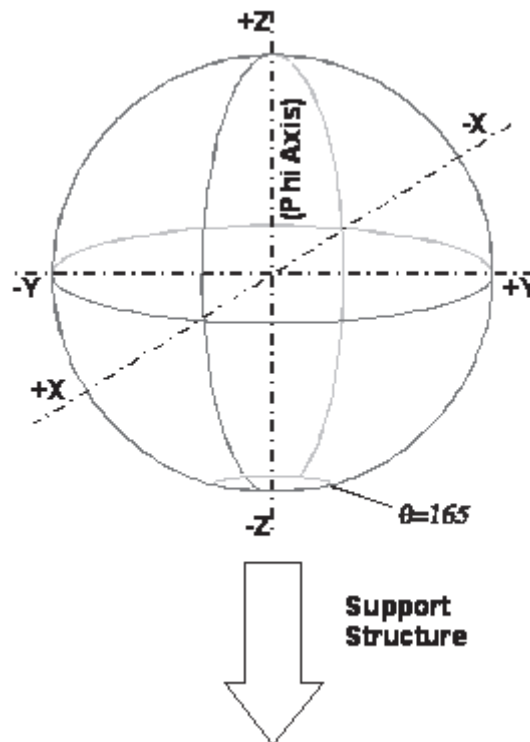

For the purposes of these tests, two principal categories of positioning systems will be defined, based on expected methods of performing spherical pattern tests. These are distributed-axes systems and combined-axes systems. Distributed-axes systems move the measurement antenna about the EUT and phi-axis positioner (Figure 3-4 a) and are representative of most conical cut method systems. Combined-axes systems mount the phi-axis positioner on the theta-axis positioner to rotate the EUT along two axes (Figure 3-4 b). Examples of this type of system include so-called multi-axis positioning systems and the manual great-circle cut method. The ripple test is intended to cover the same range of angles and perform an equivalent measurement no matter what the design of the positioning system.

FIGURE 3-4 ILLUSTRATIONS OF TYPICAL DISTRIBUTED-AXES SYSTEM (A) AND COMBINED-AXES SYSTEM (B)

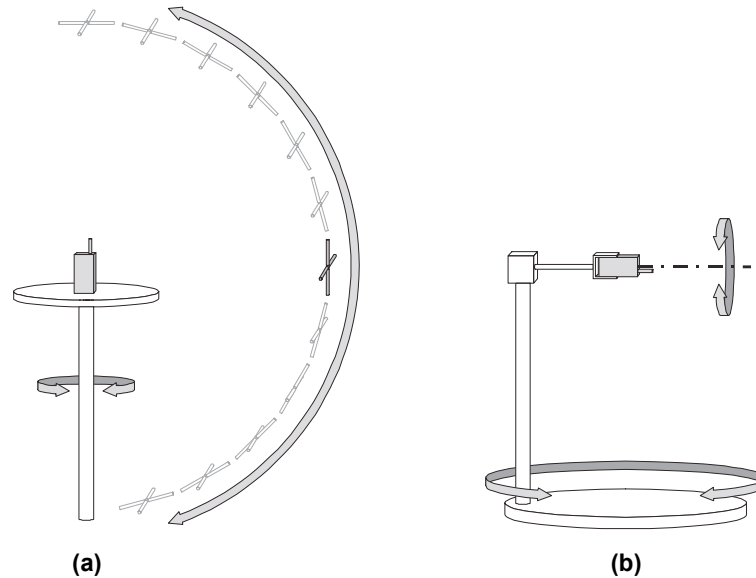

3.5 Basic Measurement Procedure

There are two main parts to the measurement procedure; the phi-axis ripple test and the theta-axis ripple test. This procedure shall be followed to verify the performance of the test system for each variation in the mounting system (i.e., free-space vs. head/hand phantom) to be used in normal testing. All required mounting structure and test equipment required for normal testing shall be in place, subject to the allowances specified below. Note that for manual great circle cut systems, it may be necessary to test each different support used to position the EUT to different phi angles.

In addition, it is necessary to ensure the symmetry of the probe antennas used to perform the test. This may be certified by a qualified calibration lab prior to their use, or may be verified onsite provided sufficient symmetry exists in the probe antenna support structure to demonstrate the required symmetry.

3.5.1 Probe Antenna Symmetry Test

This test is intended for qualification of the symmetry of the probe antennas. It is not considered a direct part of the ripple test, but rather a certification step to insure that the probe may be used to satisfy the ripple test requirements. As such, the system configuration may be modified from the ripple test configuration as required to perform this verification.

For each probe antenna to be verified, repeat the following steps:

1. Mount the probe antenna at the center of a dielectric support such that the probe's axis is centered along the positioner's axis of rotation and the axis of rotation points through the nulls in the pattern of the dipole or loop. (Normally this test would be done using the phi axis of the

positioner, but either axis is acceptable as long as the desired result is achieved). Ensure that there is no wobble in the orientation of the probe through a 360° rotation of the axis.

2. Place the Measurement Antenna in the co-polarized position (parallel to the axis of a dipole and tangential to the loop) a distance at least R (the minimum measurement distance specified in Table 3-1 for the frequency band being tested) meters away from the probe antenna. Adjust the elevation of the Measurement Antenna to be at boresight with the center of the probe antenna.
3. Attach a signal source to a coaxial cable feeding the probe antenna and set the frequency to the appropriate channel. Set the amplitude to a level appropriate for the measurement receiver. Connect a measurement receiver to the Measurement Antenna. Ensure that all coaxial cables are dressed to minimize effects upon the measurement results.
4. Rotate the probe antenna about its axis and record the signal received by the Measurement Antenna at every 2 degrees of azimuth for a total of 360°.
5. Record the measurement results to a file that can be imported into a Microsoft® Excel spreadsheet.
6. Repeat steps 1 through 6 above for each probe antenna.

Note: *The sleeve dipole and loop antennas may be combined into one reference assembly, thus allowing the two data sets to be taken conjointly.*

The total ripple observed in this symmetry test must be less than ± 0.1 dB from the mean (0.2 dB peak-to-peak) in order for the associated probe antenna to be used for the remaining tests.

3.5.2 Phi-Axis Ripple Test

The phi-axis ripple test covers a cylindrical quiet zone 300 mm in diameter around the phi axis and 300 mm long. Each probe antenna is oriented with its axis parallel to the phi axis at a total of six positions defined by three positions along the phi axis (one at the center of the quiet zone and one each \pm offset along the phi axis), combined with one 150 mm offset perpendicular to the phi axis for each axial offset. At each position, the phi axis is rotated 360° with the measurement antenna positioned at $\theta = 90^\circ$ to record the ripple. Each position is labeled by its radial and axial offset from the center position, (R,Z), using 0, +, or – to represent the appropriate offset in each direction. See Figure 3-5 for additional information.

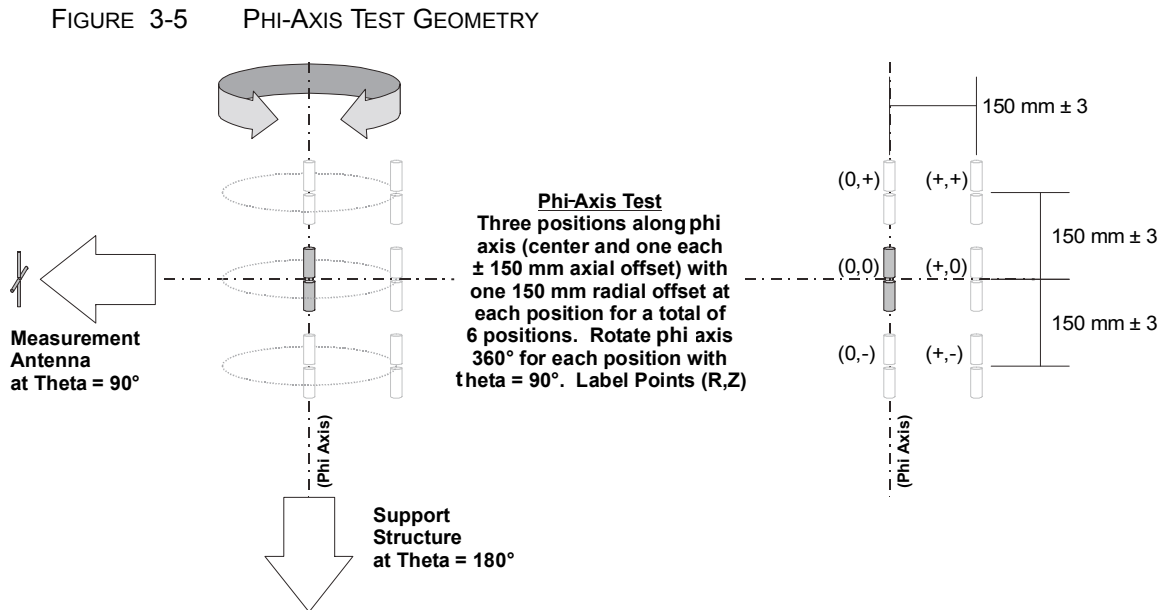

For each polarization and band, repeat the following steps:

1. Place the Measurement Antenna and any associated theta-axis positioner at $\theta = 90^\circ$ such that the Measurement Antenna is boresight with the center of the quiet zone. The Measurement Antenna should be at the same separation distance to be used for actual pattern measurements. This distance must be at least R (the minimum measurement distance specified in Table 3-1 for the frequency band being tested) meters away from the center of the quiet zone. Select or adjust the polarization to correspond to the polarization (θ or ϕ) to be tested.
2. Mount the probe antenna to the phi-axis positioner using a low permittivity dielectric support. Use the sleeve dipole for the θ polarization and the loop for the ϕ polarization. At each of the six offset positions, ensure that the axis of the probe is parallel to the ϕ axis of rotation.
3. Attach a signal source to a coaxial cable feeding the probe antenna and set the frequency to the appropriate channel. Set the amplitude to a level appropriate for the measurement receiver. Connect a measurement receiver to the Measurement Antenna. The received signal during the ripple test measurement should be at least 40 dB above the noise floor or noise errors greater than 0.1 dB will result. Ensure that all coaxial cables are dressed to minimize effects upon the measurement results.
4. Rotate the probe antenna about the ϕ axis and record the signal received by the Measurement Antenna at every 2 degrees of azimuth for a total of 360° .
5. Record the measurement results to a file that can be imported into a Microsoft® Excel spreadsheet.
6. Record test parameters including: (a) the distance between the measurement and probe antennas, (b) cable losses and other losses associated with the measurement setup, (c) the power of the signal source at the probe antenna connector, and (d) the noise level of the receiver with no signal applied.

7. Repeat steps 1 through 6 above for each probe antenna (polarization and band) for each of the 6 test positions, offsetting 150 mm \pm 3 mm from the center of the quiet zone in each direction along the phi axis and radially from the center.

3.5.3 Theta-Axis Ripple Test

The theta-axis ripple test covers a quiet zone sphere 300 mm in diameter. Each probe antenna is oriented with its axis parallel to the theta axis at a total of seven positions defined by two 150 mm offsets along each Cartesian axis. At each position, the theta axis is rotated from -165° to 165° with the Measurement Antenna positioned at $\phi = 0^\circ$, or for two separate tests from $1-165^\circ$ with the measurement antenna positioned at $\phi = 0^\circ$ and again at $\phi = 180^\circ$, to record the ripple. Each position is labeled by its offset from the center position along each axis, (X, Y, Z), using 0, +, or - to represent the appropriate offset in each direction. See [Figure 3-6](#) for additional information.

FIGURE 3-6 THETA-AXIS TEST GEOMETRY

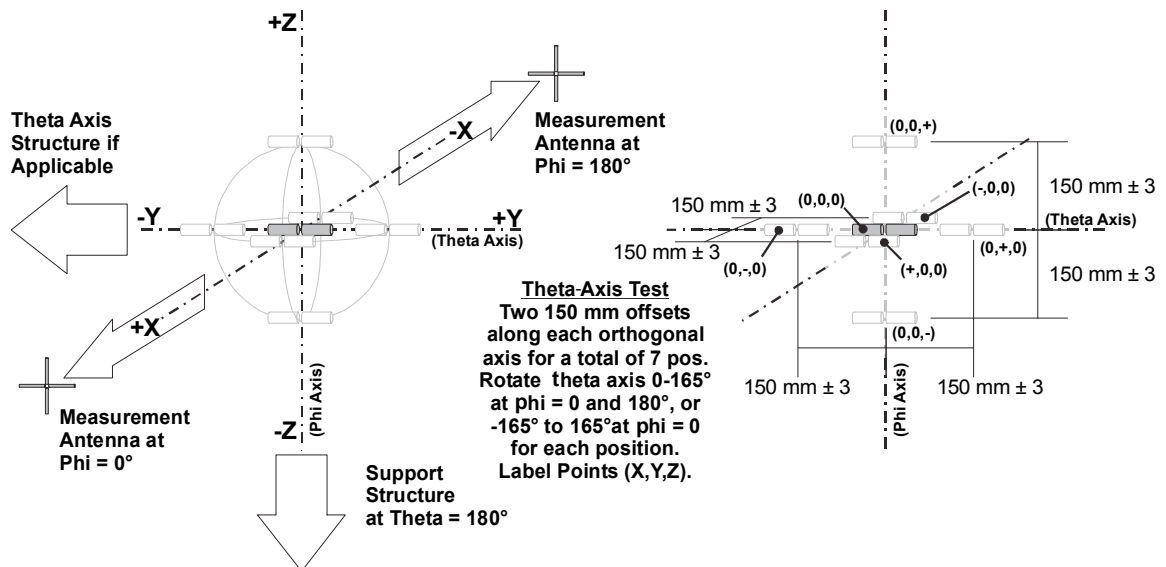

For each polarization and band, repeat the following steps:

1. Place the Measurement Antenna such that it is boresight with the center of the quiet zone. The antenna should be at the same separation distance to be used for actual pattern measurements. This distance must be at least R (the minimum measurement distance specified in [Table 3-1](#) for the frequency band being tested) meters away from the center of the quiet zone. Select or adjust the polarization to correspond to the polarization (theta or phi) to be tested.
2. With the phi-axis positioner set to 0° (or for both $\phi = 0$ and 180° in cases where the theta positioner range of motion is less than $\pm 165^\circ$) mount the probe antenna with its axis parallel to the theta axis of rotation using a low permittivity dielectric support. Use the sleeve dipole for the phi polarization and the loop for the theta polarization. At each of the seven offset positions, ensure that the axis of the probe is parallel to the theta axis of rotation. In cases where the theta positioner range of motion is less than $\pm 165^\circ$, the probe antenna and

associated cables should maintain the same orientation with respect to the phi-axis positioner structure for both the $\phi = 0$ and 180° test cases. (That is, the probe should be mounted such that it rotates with the phi positioner.)

3. Attach a signal source to a coaxial cable feeding the probe antenna and set the frequency to the appropriate channel. Set the amplitude to a level appropriate for the measurement receiver. Connect a measurement receiver to the Measurement Antenna. The received signal during the ripple test measurement should be at least 40 dB above the noise floor or noise errors greater than 0.1 dB will result. Ensure that all coaxial cables are dressed to minimize effects upon the measurement results.
4. Rotate the probe antenna about the theta axis and record the signal received by the Measurement Antenna at every 2 degrees of azimuth for a total of 330° , or two separate tests of 164° .

Note: To cover the same range of angles at 2° steps, the range of the two individual tests is reduced by one degree since the zero degree position is not measured.

5. Record the measurement results to a file that can be imported into a Microsoft® Excel spreadsheet.
6. Record test parameters including: (a) the distance between the measurement and probe antennas, (b) cable losses and other losses associated with the measurement setup, (c) the power of the signal source at the probe antenna connector, and (d) the noise level of the receiver with no signal applied.
7. Repeat steps 1 through 6 above for each probe antenna (polarization and band) for each of the 7 test positions, offsetting $150 \text{ mm} \pm 3 \text{ mm}$ from the center of the quiet zone along each of the six cardinal directions.

3.5.4 Allowances and Adjustments

When implementing these tests on actual positioning systems, it is possible that there will be interference issues between the required test positions and the mechanical support structure required to hold the EUT or head/hand phantom during a test. This section details a list of allowances whereby the test system may be modified slightly from its normal test configuration in order to perform the ripple tests. Where possible, the alterations to the system should be minimized, and the final acceptability of any adjustment shall be the decision of the appropriate CTIA Certification subject matter expert (SME).

1. The portion of the support structure required to mount the EUT to the phi-axis positioning structure for the free-space test may be removed to clear the region of the quiet zone for the ripple test for both axes. The tester should be prepared to show that the structure removed has a negligible impact on the free-space pattern measurement of the EUT, compared to the remaining structure included in the ripple test.
2. Support materials with a dielectric constant less than 1.2 may be removed to a maximum distance of 250 mm outside the quiet zone (400 mm from the center).
3. An adapter plate comprising up to 13 mm of dielectric material with a permittivity less than 4.5 and residing wholly within the footprint of the base of the head phantom base may be considered part of the head phantom and removed with the head phantom for the purposes of the ripple test. In addition, any support structure used to hold the hand phantom should be removed, because a separate uncertainty term is used to address its effect.
4. For the phi-axis ripple test, where mechanical interference with support structure may prevent rotation of the probe antennas around the phi axis, the phi-axis positioning structure may be moved away from the quiet zone the minimum distance required to perform the (X,-) position tests. It should not be necessary to move the support for the remaining phi-axis positions.

5. To avoid near-field effects that may incorrectly bias the ripple test, no remaining support material with a dielectric constant greater than 1.2 should be within 75 mm of any point on the physical surface of the antenna portion of any probe. This is primarily expected to be an issue for the theta-axis test where loops and dipoles may be expected to physically intersect with any remaining head phantom support. To accommodate this possibility without eliminating a required test point, the test point closest to the phi-axis support (0,0,-) may be substituted with one of the following tests, in order of preference:
 - a. The maximum of the two points defined by offsetting 150 mm \pm 3 mm in either direction parallel to the theta axis (Y-axis) from the (0,0,-) point, labeled as (0,+,-) and (0,-,-), may be substituted for (0,0,-).
 - b. If both of those points cannot be measured, either:
 - The maximum of the two points defined by offsetting 150 mm \pm 3 mm in either direction along the direction perpendicular to both the theta and phi axes (X-axis) from the (0,0,-) point, labeled as (+,0,-) and (-,0,-), may be substituted for (0,0,-).
OR
 - The phi-axis positioning structure may be moved away from the quiet zone the minimum distance required to provide the required clearance from the surface of the probe antennas

FIGURE 3-7 ILLUSTRATION OF ALTERNATE PROBE POSITIONS ALLOWED FOR THETA-AXIS TEST

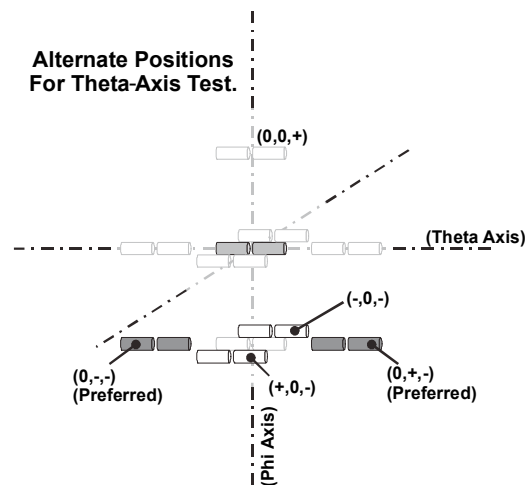

6. In case the θ -axis or ϕ -axis positioning systems cannot accommodate 2° angular resolution, a coarser angular sampling is allowed provided the number of offset positions along the cardinal axes is increased accordingly. In any case, the sample spacing shall not exceed 15° . The offset positions shall be computed in the following manner:
 - a. Determine the ratio of the achievable angular resolution to the nominally specified 2° resolution.
 - b. Round this ratio up to the next whole number.
 - c. Divide 150 mm by the number obtained above and round to the nearest 5 mm. This will be the offset increment.
 - d. Starting from the center, create the list of offset positions along the cardinal axes, each position separated by the offset increment. The last offset will be exactly 150 mm, even if

the distance between the penultimate and last offset positions will be less than one increment (See examples in [Table 3-4](#)).

Consider the following acceptable examples for various angular resolutions:

TABLE 3-4 EXAMPLE SCENARIOS FOR REDUCED ANGULAR RESOLUTION RIPPLE TESTS

Angular Resolution (deg)	Rounded Ratio of Resolution Relative to 2°	Offset Increment (mm)	X-Offsets (mm)	Y-Offsets (mm)	Z-Offsets (mm)
2	1	150	±150	±150	±150
5	3	50	±50, ±100, ±150	±50, ±100, ±150	±50, ±100, ±150
10	5	30	±30, ±60, ±90, ±120, ±150	±30, ±60, ±90, ±120, ±150	±30, ±60, ±90, ±120, ±150
15	8	20	±20, ±40, ±60, ±80, ±100, ±120, ±140, ±150	±20, ±40, ±60, ±80, ±100, ±120, ±140, ±150	±20, ±40, ±60, ±80, ±100, ±120, ±140, ±150

3.6 Additional Ripple Test Requirements for Notebook-Sized Test Volumes

Prior to certification testing of notebooks or similar devices not fitting within a 300 mm diameter sphere, additional ripple tests will be required. The quiet zone shall be probed following the methods described in [Section 3.4](#) and [Section 3.5](#), but with added probe antenna offsets corresponding to the largest volume for which the test system will be authorized. Additional allowances have been incorporated in the test procedure to accommodate ripple testing with commonly used positioners and fixtures previously certified for handset testing. The overall results shall be used in estimating measurement uncertainty for these larger devices. To have the most accurate uncertainty estimates for different types of test objects, it is recommended that the ATL provides separate uncertainty calculations for handset measurements and notebook measurements.

The following subsections describe changes and additions to the tests described in [Section 3.5](#) for a notebook type device with maximum physical dimension, D . For notebook testing, D shall be assumed to be 500 mm, which accounts for the maximum distance from corner to corner in the largest available “desktop replacement” notebooks. Notebooks with large form factors typically are wider than tall and have the embedded antennas located in the display. For these reasons and to accommodate existing positioner systems, the ripple test will assume that there will be no source of radiation at $Z < -150$ mm. The effective ripple scan volume will be a cylinder of diameter $D = 500$ mm and axial extension from $Z = -150$ mm to $Z = 210$ mm. See [Figure 3-8](#) for an illustration of the alternate test volume for notebooks.

FIGURE 3-8 ILLUSTRATION OF THE INCREASE IN TEST VOLUME FOR NOTEBOOKS

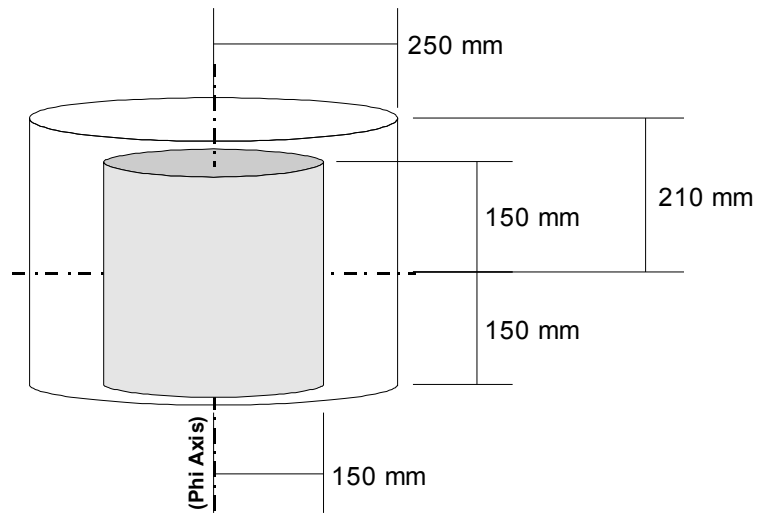

3.6.1 Probe Antenna Symmetry Test

Provided all ripple tests are performed using the same probe antennas, no additional testing is required to validate the probe antenna symmetry.

3.6.2 Extensions to Phi-Axis Ripple Test

Perform the test as described in [Section 3.5.2](#) for all probe antennas and all bands, but at four additional probe antenna offsets along the radial and axial directions. The four supplementary (R,Z) positions will then be at (0, +210 mm), (+250 mm, -150 mm), (+250 mm, 0), (+250 mm, +210 mm).

FIGURE 3-9 ILLUSTRATION OF THE ADDITIONAL PHI-AXIS RIPPLE TEST LOCATIONS FOR NOTEBOOKS

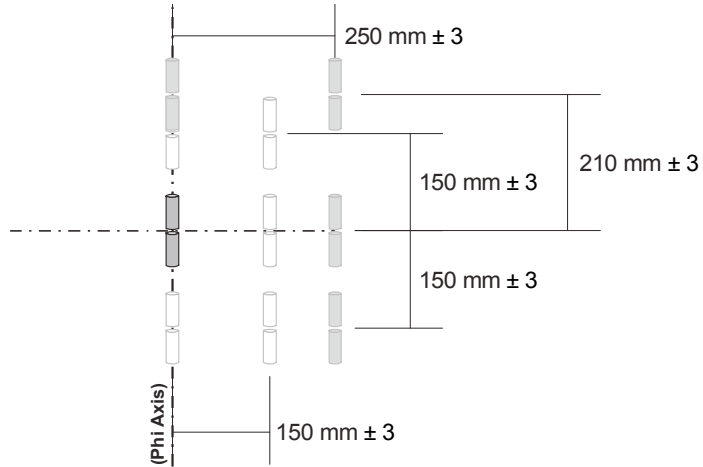

3.6.3 Extension to Theta-Axis Ripple Test

Perform the test as described in [Section 3.5.3](#) for all probe antennas and all bands, but at five additional offset positions. The five supplementary positions will be along the cardinal axes at (X,Y,Z) coordinates given by (± 250 mm, 0, 0), (0, ± 250 mm, 0), and (0, 0, +210 mm).

FIGURE 3-10 ILLUSTRATION OF THE ADDITIONAL THETA-AXIS RIPPLE TEST LOCATIONS FOR NOTEBOOKS

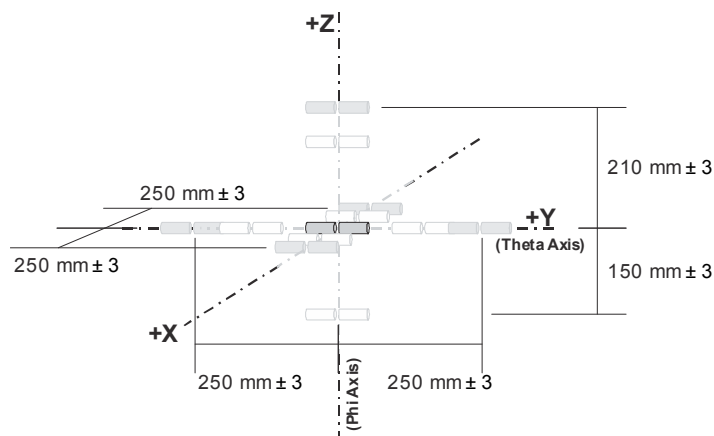

3.6.4 Additions to Allowances and Adjustments

This section describes modifications to the allowances that are given in [Section 3.5.4](#) that will be made to accommodate the ripple test in practical automated systems. Where possible, the alterations to the system should be minimized, and the final acceptability of any adjustment shall be the decision of the appropriate CTIA Certification subject matter expert (SME).

1. The portion of the support structure required to mount the EUT to the phi-axis positioning structure for the free-space test may be removed to clear the region of the quiet zone for the ripple test for both axes. The tester should be prepared to show that the structure removed has a negligible impact on the free-space pattern measurement of the EUT, compared to the remaining structure included in the ripple test.
2. Support materials with a dielectric constant less than 1.2 may be removed to a maximum distance of 250 mm outside the quiet zone (400 mm from the center).
3. An adapter plate comprising up to 13 mm of dielectric material with a permittivity less than 4.5 and residing wholly within the footprint of the notebook base may be considered part of the notebook and removed for purposes of the ripple test. Additional dielectric brackets and fixtures necessary to maintain screen notebook and display position will also be removed for the purposes of the ripple test, provided the dielectric material has a permittivity of less than 4.5, and these materials protrude less than 13 mm beyond any surface of the notebook, and such fixtures are not physically located within 100 mm of the tested antenna(s) in the device.
4. For the phi-axis ripple test, where mechanical interference with support structure may prevent rotation of the probe antennas around the phi-axis, the phi-axis positioning structure may be moved away from the quiet zone the minimum distance required to perform the (+250 mm, -150 mm) position tests. It should not be necessary to move the support for the remaining phi-axis positions.
5. To avoid near-field effects that may incorrectly bias the ripple test, no remaining support material with a dielectric constant greater than 1.2 should be within 75 mm of any point on the physical surface of the antenna portion of any probe. This is primarily expected to be an issue for the theta-axis test where loops and dipoles may be expected to physically intersect with any remaining SAM phantom support. As this ripple test has been limited to -150 mm offsets along the Z-axis, the following text is identical to the text in [Section 3](#) except that for clarity, the “+/-” notation has been replaced with specific coordinates. The test point closest to the phi-axis support (0, 0, -150 mm) may be substituted with one of the following tests, in order of preference:
 - a. The maximum of the two points defined by offsetting 150 mm ± 3 mm in either direction parallel to the theta axis (Y-axis) from the (0,0, -150 mm) point, labeled as (0, +150 mm, -150 mm) and (0, -150 mm, -150 mm), may be substituted for (0, 0, -150 mm).
 - b. If both of those points cannot be measured, either:
 - The maximum of the two points defined by offsetting 150 mm ± 3 mm in either direction along the direction perpendicular to both the theta- and phi-axes (X-axis) from the (0, 0, -150 mm) point, labeled as (150 mm, 0, 150 mm) and (-150 mm, 0, -150 mm), may be substituted for (0, 0, -150 mm).
 or
 - The phi-axis positioning structure may be moved away from the quiet zone the minimum distance required to provide the required clearance from the surface of the probe antennas.
6. In case the θ -axis or ϕ -axis positioning systems cannot accommodate 2° angular resolution, a coarser angular sampling is allowed provided the number of offset positions along the

cardinal axes is increased accordingly. In any case, the sample spacing shall not exceed 15° . The offset positions shall be computed in the following manner:

- Determine the ratio of the achievable angular resolution to the nominally specified 2° resolution.
- Round this ratio up to the next whole number.
- Multiply this ratio by 0.4 to account for the increase in radius of the test volume.
- Round this ratio up to the next whole number.
- Divide 100 mm by the number obtained above and round to the nearest 5 mm. This will be the offset increment.
- Starting from 150 mm, create the list of offset positions along the cardinal axes, each position separated by the offset increment calculated above. The last offset will be exactly 250 mm for the X- and Y-axes and 210 mm for the +Z-axis, even if the distance between the penultimate and last offset positions will be less than one increment.

3.7 Applying the Ripple Test Procedure to Specific Systems

The procedure presented in the previous sections should be applicable to any fully automated spherical pattern measurement system. This section provides several illustrations to assist in interpretation of the requirements for different system types.

FIGURE 3-11 PHI-AXIS TEST GEOMETRY FOR A TYPICAL DISTRIBUTED-AXES SYSTEM (A), AND A TYPICAL COMBINED-AXES SYSTEM (B)

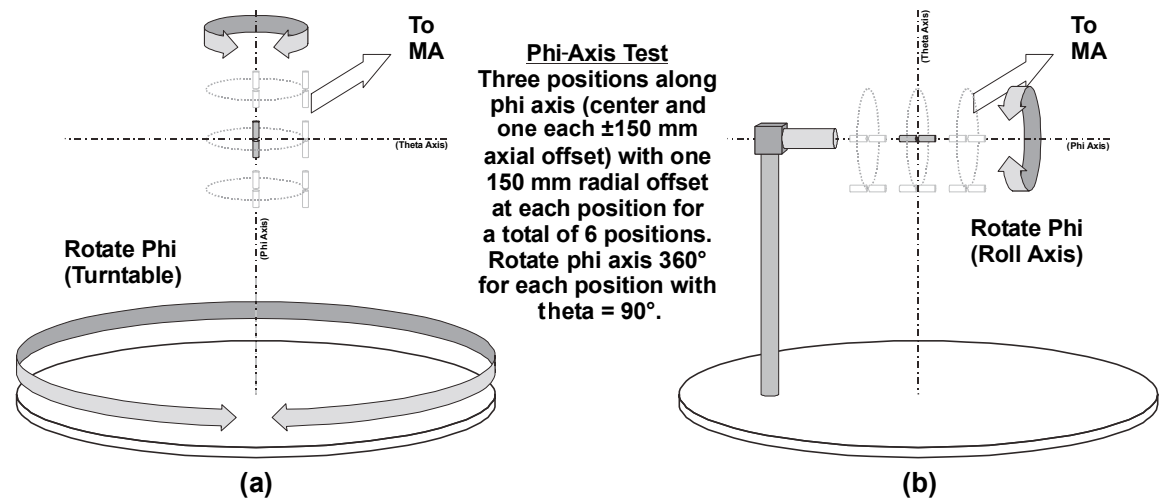

FIGURE 3-12 THETA-AXIS TEST GEOMETRY FOR A TYPICAL DISTRIBUTED-AXES SYSTEM (A), AND A TYPICAL COMBINED-AXES SYSTEM (B)

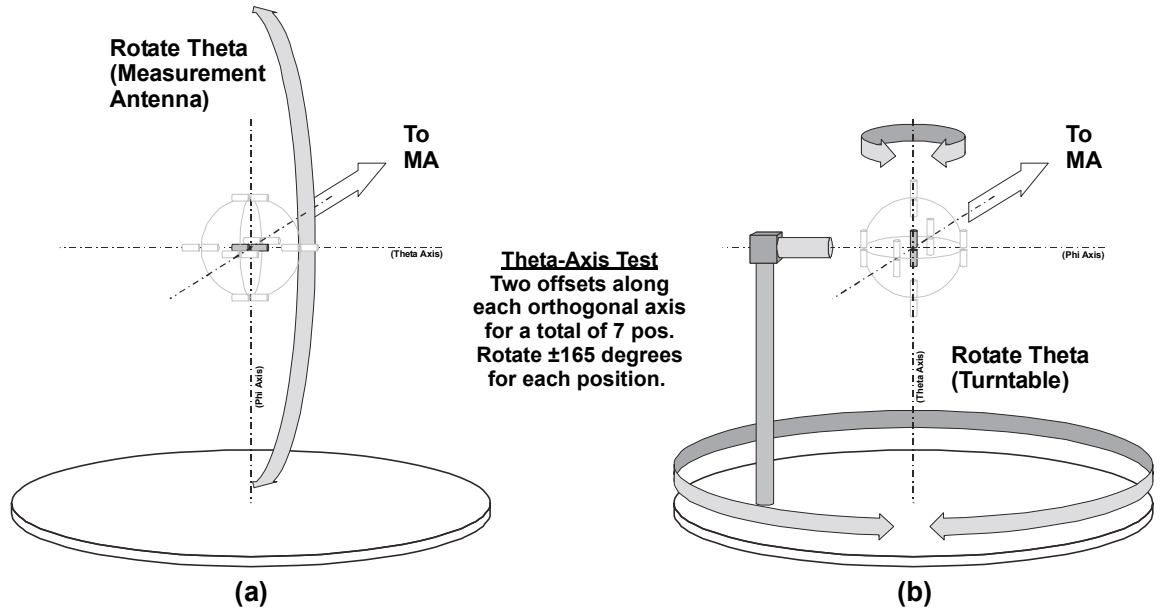
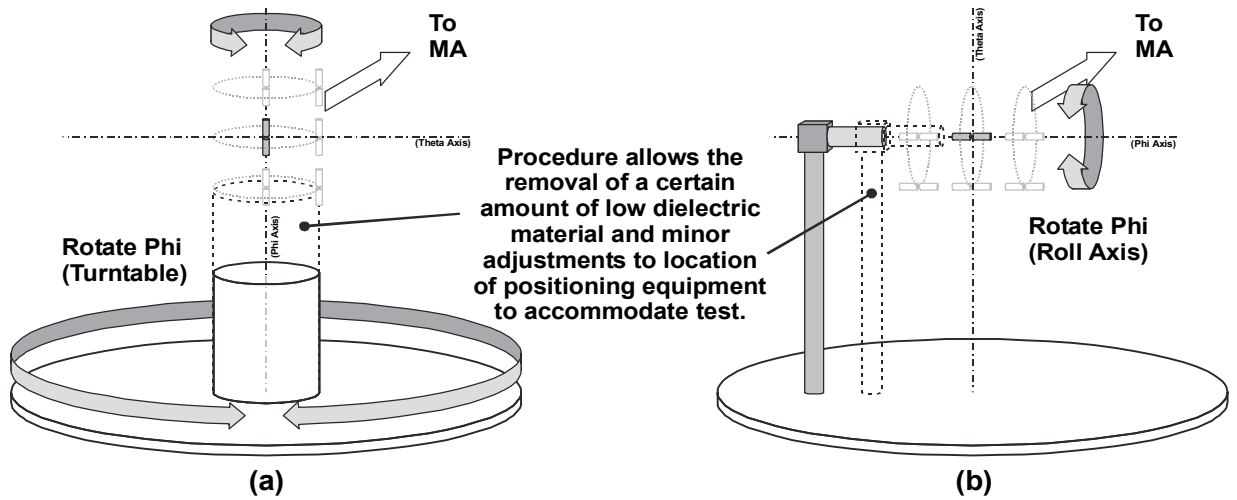
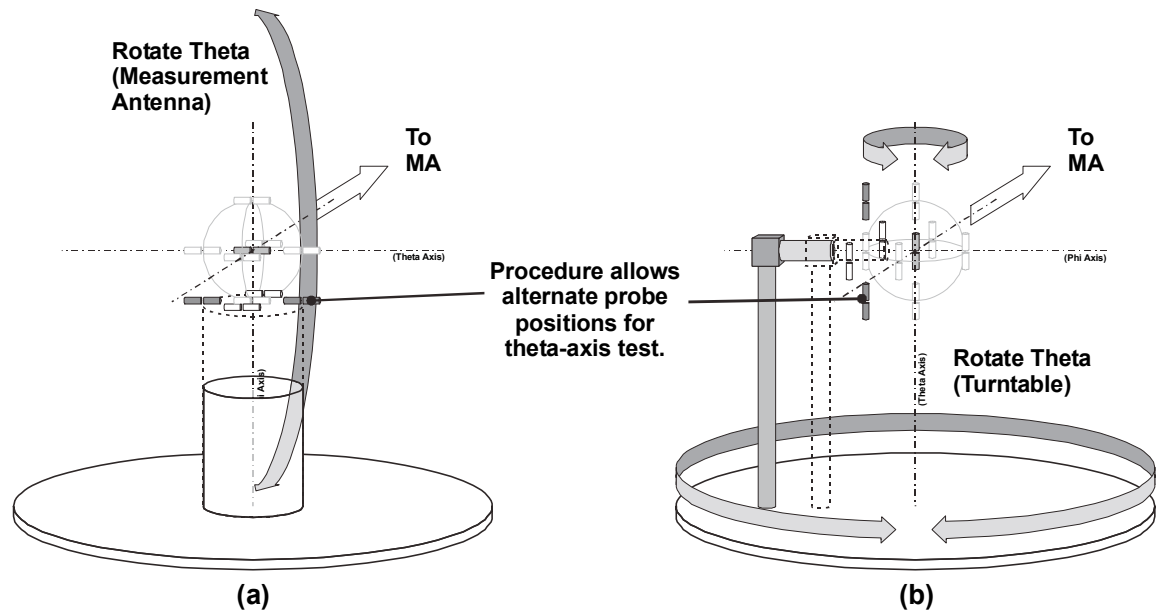

FIGURE 3-13 EXAMPLE ILLUSTRATING SOME ALLOWED ALTERATIONS OF TEST SETUP FOR PHI-AXIS



Refer to text for details.

FIGURE 3-14 EXAMPLE ILLUSTRATING ALTERNATE POSITIONS AND ALLOWED ALTERATIONS FOR THETA-AXIS TEST



Refer to text for details.

3.8 Analysis

1. Adjust the off-axis ripple measurements to correct for distance variation using the equation for the Law of Cosines (see [Figure 3-15](#)).

Note: For long range lengths where this adjustment may be considered negligible, it is not required to apply the correction.

2. Plot the corrected patterns using polar coordinates.
3. Use the procedures defined in [Appendix G.8.1.1](#) to calculate the resulting measurement uncertainty due to the ripple test results.
4. The plot and calculated results are to be supplied as part of the ATL authorization process.

Law of Cosines Adjustment Method (for Far-Field testing)

For coplanar antennas, the Law of Cosines may be used to determine the distance between antennas as one is rotated about a center axis. Since each ripple test measurement is self-referencing, minor differences in elevation will have only second or third order effects on the result. Refer to [Figure 3-15](#) to aid in understanding this discussion.

Note: This illustration is a view from the perspective of looking down on vertically oriented antennas from above.

FIGURE 3-15 GEOMETRY FOR LAW OF COSINES RANGE LENGTH ADJUSTMENT

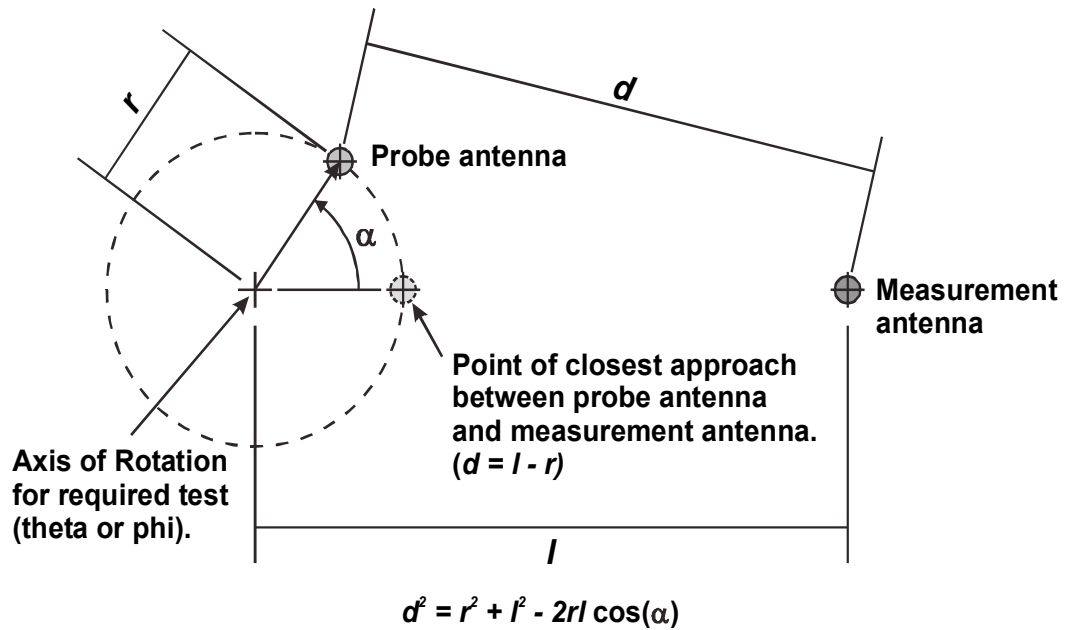

- Let l be the distance measured between the axis of rotation and the Measurement Antenna
- Let r be the measured distance that the probe antenna is offset from the axis of rotation.
- Let α be the rotation angle of the probe antenna where 0-degrees is the point where the probe antenna is closest to the Measurement Antenna and 180-degrees is the point where the probe antenna is farthest away from the Measurement Antenna. This is either the theta or phi angle for the associated ripple test, with the required angular offset applied (i.e. $\alpha = \theta + 0, 90, \text{ or } 180^\circ$). The corrections for the phi-axis test may be simplified by starting with the probe antenna closest to the measurement antenna so that $\alpha = \phi$.
- Let d be the calculated distance between the probe antenna and the Measurement Antenna. Then d may be calculated from the Law of Cosines as follows:

EQUATION 3.1

$$d^2 = r^2 + l^2 - 2rl \cos(\alpha)$$

- Adjust the measured signal power to account for distance variation using the following equation:

EQUATION 3.2

$$P_{adj} \text{ (dBm)} = P_{meas} \text{ (dBm)} + 20 \log (d/l) \text{ (dB)}$$

Note: Parameter r and l must be carefully measured and recorded to enable accurate application of this technique.

Section 4 Range Reference Requirements

This section describes the required procedure for obtaining the reference measurement used in removing the test system's influence from the Radiated Power and Sensitivity measurements. Before accurate measurements of quantities such as TRP, EIRP, TIS, or EIS can be made, it is necessary to perform a reference measurement to account for the various factors affecting the measurement of these quantities. These factors include components like range length path loss, gain of the receive antenna, cable losses, and so forth. This reference measurement is done using a reference antenna (typically either a dipole or standard gain horn) with known gain characteristics. The reference antenna is mounted at the center of the quiet zone to serve as the substitution antenna under test (AUT). The reference measurement is repeated for each variation of the measurement system (i.e., each polarization of the receive antenna, and each possible signal path to the measurement equipment). The reference measurement is combined with the gain of the reference antenna to determine an isotropic reference correction to be applied to EUT measurements performed using the test system.

This procedure shall be repeated annually, and any time there is a change in the measurement system that may affect the validity of this reference measurement. For non-permanent range installations (those where elements of the test system are disassembled or removed between tests) this procedure shall be repeated each time the range is reconfigured. It is recommended to perform this procedure on a monthly or quarterly basis to determine system stability.

4.1 Theoretical Background

Each individual data point in a radiated power or sensitivity measurement is referred to as the effective isotropic radiated power or effective isotropic sensitivity. That is, the desired information is how the measured quantity relates to the same quantity from an isotropic radiator. Thus, the reference measurement must relate the power received or transmitted at the EUT test equipment (spectrum analyzer or communication tester) back to the power transmitted or received at a theoretical isotropic radiator. The total path loss then, is just the difference in dB between the power transmitted or received at the isotropic radiator and that seen at the test equipment (see [Figure 4-1](#)).

FIGURE 4-1 THEORETICAL CASE FOR DETERMINING PATH LOSS

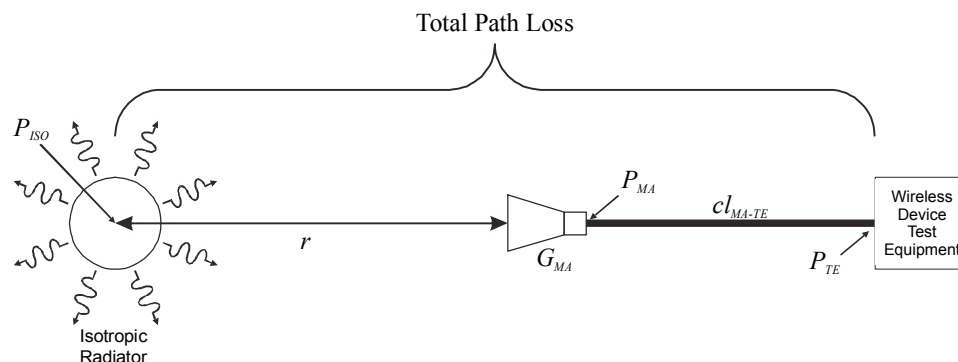

In equation form, this becomes:

EQUATION 4.1

$$PL = P_{ISO} - P_{TE}$$

where PL is the total path loss, P_{ISO} is the power radiated by the theoretical isotropic radiator, and P_{TE} is the power received at the test equipment port. As can be seen in Figure 4-1, this quantity includes the range path loss due to the range length r , the gain of the measurement antenna, and any loss terms associated with the cabling, connections, amplifiers, splitters, etc. between the measurement antenna and the test equipment port.

Figure 4-2 shows a typical real world configuration for measuring the path loss. In this case, a reference antenna with known gain is used in place of the theoretical isotropic source. The path loss may then be determined from the power into the reference antenna by adding the gain of the reference antenna. That is:

EQUATION 4.2

$$P_{ISO} = P_{RA} + G_{RA}$$

where P_{RA} is the power radiated by reference antenna, and G_{RA} is the gain of the reference antenna, so that:

EQUATION 4.3

$$PL = P_{RA} + G_{RA} - P_{TE}$$

FIGURE 4-2 TYPICAL CONFIGURATION FOR MEASURING PATH LOSS

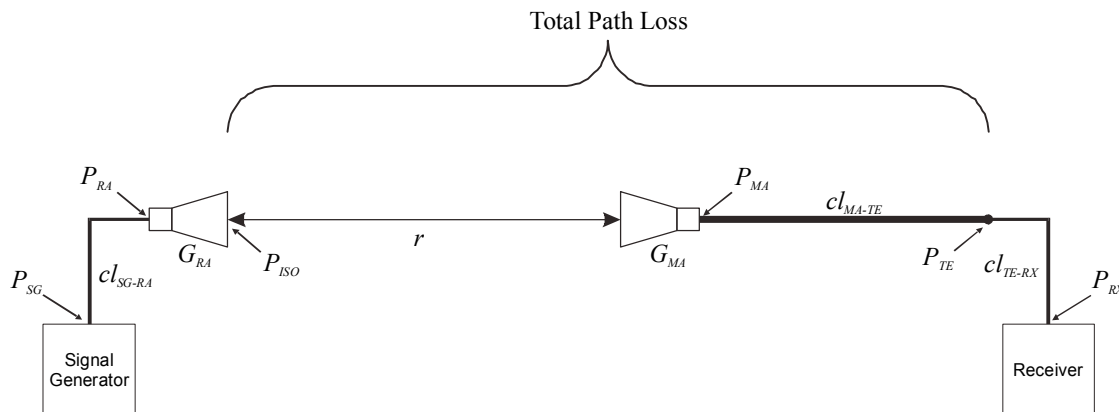

In order to determine P_{RA} , it is necessary to perform a cable reference measurement to remove the effects of the cable loss between signal generator and reference antenna cl_{SG-RA} , and between the test equipment port and the receiver. This establishes a reference point at the input to the reference antenna. Figure 4-3 illustrates the cable reference measurement configuration. Assuming the power level at the signal generator is fixed, it is easy to show that the difference between P_{RA} and P_{TE} in Figure 4-2 is given by:

EQUATION 4.4

$$P_{RA} - P_{TE} = P_{RX}' - P_{RX}$$

FIGURE 4-3 CABLE REFERENCE CALIBRATION CONFIGURATION

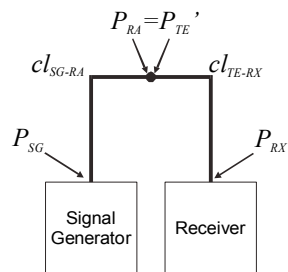

where P_{RX}' is the power measured at the receiver during the cable reference test, and P_{RX} is the power measured at the receiver during the range path loss measurement in Figure 4-2. Note that this formulation assumes that the effects of the reference antenna VSWR are accounted for in the gain of the reference antenna. For more information on this subject, refer to [1]. Thus, the path loss is then just given by:

EQUATION 4.5

$$PL = G_{RA} + P_{RX}' - P_{RX}$$

4.2 Equipment Required

1. Anechoic chamber and spherical positioning system previously characterized per, and meeting the requirements specified in Section 3.
2. Reference antenna(s) with valid calibrations to cover the required range of test frequencies. Low uncertainty precision calibrated sleeve dipoles are recommended as the reference antenna up to 2.5 GHz. Standard gain horns are recommended above 2.5 GHz. The calculated gain of standard gain antennas may be used provided the performance of the antenna has been verified and an uncertainty value has been determined for the calculated gain of the antenna. Other antennas may be used; however, the uncertainty contribution to the resulting measurements due to calibration and phase center issues may be significant.
3. Low dielectric constant support structure (e.g., Styrofoam) for positioning the reference antennas.
4. Measurement antenna(s) (e.g. horn or dipole used to perform measurements of the EUT).

Note: If multiple measurement antennas are used to cover the required frequency range, the reference measurement must be repeated each time the antennas are repositioned, unless a permanent mounting fixture is used to guarantee repeatable performance. These should be the same antennas used in performing the site characterization in Section 3.

5. Network analyzer, spectrum analyzer with tracking generator, or stable signal generator and measurement receiver (spectrum analyzer, power meter, etc.) having a wide dynamic range and high linearity, all with current calibration(s).

6. All RF cabling, splitters, combiners, switches, attenuators, etc. required to connect the measurement antenna(s) to the test equipment used for measuring radiated power and sensitivity of the EUT. The connection to the receiver or communication tester used to perform the EUT measurement shall be referred to as the “test port” in this section. These components will be characterized along with the range length and measurement antenna contributions.
7. Additional cabling to reach from the signal source to the reference antenna (the reference port), and from both the reference antenna location and the test port to the receiver input. The source cabling to the reference antenna should be treated with ferrite beads and routed to minimize its influence on the reference measurement. The effects of these cables will be removed from the reference measurement; however, cable lengths should be kept as short as possible to reduce the associated path loss.
8. Low loss cable adapters for performing various interconnects. These should be characterized to determine their influence on the measurements. That influence may be corrected for if measured, or applied to the measurement uncertainty if estimated.
9. Optional 3 to 10 dB fixed attenuators for reducing standing wave effects in cables.
10. Optional 50 Ω terminations.

4.3 Test Frequencies

Table 4-1 provides the minimum list of reference frequencies to be measured. This assumes that the performance of the test system is relatively flat so that minor variations in frequency around these points will have negligible effect on the reference value. If this is not the case, additional points should be taken to cover each expected EUT test frequency. A swept spectrum reference measurement is recommended to ensure that there aren't any sharp resonances in the measurement system near a required test frequency.

TABLE 4-1 TEST FREQUENCIES FOR THE REFERENCE MEASUREMENT

Band	Frequency (MHz)
3GPP Band 71, TX low	663
3GPP Band 71, RX low	617
3GPP Band 71, TX mid	680.5
3GPP Band 71, RX mid	634.5
3GPP Band 71, TX high	698
3GPP Band 71, RX high	652
3GPP Band 12, TX low	699
3GPP Band 12, RX low	729
3GPP Band 12, TX mid	707.5
3GPP Band 12, RX mid	737.5
3GPP Band 12, TX high	716
3GPP Band 12, RX high	746
3GPP Band 17, TX low	704
3GPP Band 17, RX low	734

TABLE 4-1 TEST FREQUENCIES FOR THE REFERENCE MEASUREMENT

Band	Frequency (MHz)
3GPP Band 17, TX mid	710
3GPP Band 17, RX mid	740
3GPP Band 17, TX high	716
3GPP Band 17, RX high	746
3GPP Band 29, RX low	717
3GPP Band 29, RX mid	722.5
3GPP Band 29, RX high	728
3GPP Band 13, TX low	777
3GPP Band 13, RX low	746
3GPP Band 13, TX mid	782
3GPP Band 13, RX mid	751
3GPP Band 13, TX high	787
3GPP Band 13, RX high	756
3GPP Band 14, TX low	788
3GPP Band 14, RX low	758
3GPP Band 14, TX mid	793
3GPP Band 14, RX mid	763
3GPP Band 14, TX high	798
3GPP Band 14, RX high	768
3GPP Band 26, TX low	814
3GPP Band 26, RX low	859
3GPP Band 26, TX mid	831.5
3GPP Band 26, RX mid	876.5
3GPP Band 26, TX high	849
3GPP Band 26, RX high	894
Cellular (3GPP Band 5), TX low	824
Cellular (3GPP Band 5), RX low	869
Cellular (3GPP Band 5), TX mid	836.5
Cellular (3GPP Band 5), RX mid	881.5
Cellular (3GPP Band 5), TX high	849
Cellular (3GPP Band 5), RX high	894
MBS (M-LMS Band)	925.977
GPS L1	1575.42
GLONASS	1602
PCS (3GPP Band 2), TX low	1850
PCS (3GPP Band 2), RX low	1930
PCS (3GPP Band 2), TX mid	1880

TABLE 4-1 TEST FREQUENCIES FOR THE REFERENCE MEASUREMENT

Band	Frequency (MHz)
PCS (3GPP Band 2), RX mid	1960
PCS (3GPP Band 2), TX high	1910
PCS (3GPP Band 2), RX high	1990
3GPP Band 25, TX low	1850
3GPP Band 25, RX low	1930
3GPP Band 25, TX mid	1882.5
3GPP Band 25, RX mid	1962.5
3GPP Band 25, TX high	1915
3GPP Band 25, RX high	1995
3GPP Band 70, TX low	1695
3GPP Band 70, RX low	1995
3GPP Band 70, TX mid	1702.5
3GPP Band 70, RX mid	2002.5
3GPP Band 70, TX high	1710
3GPP Band 70, RX high	2010
3GPP Band 70, DL only RX high	2020
AWS-1 (3GPP Band 4), TX low	1710
AWS-1 (3GPP Band 4), RX low	2110
AWS-1 (3GPP Band 4), TX mid	1732.5
AWS-1 (3GPP Band 4), RX mid	2132.5
AWS-1 (3GPP Band 4), TX high	1755
AWS-1 (3GPP Band 4), RX high	2155
3GPP Band 66, TX low	1710
3GPP Band 66, RX low	2110
3GPP Band 66, TX mid	1745
3GPP Band 66, RX mid	2145
3GPP Band 66, TX high	1780
3GPP Band 66, RX high	2180
3GPP Band 66, DL only RX high	2200
3GPP Band 30, TX low	2305
3GPP Band 30, RX low	2350
3GPP Band 30, TX mid	2310
3GPP Band 30, RX mid	2355
3GPP Band 30, TX high	2315
3GPP Band 30, RX high	2360
3GPP Band 7, TX low	2500
3GPP Band 7, RX low	2620

TABLE 4-1 TEST FREQUENCIES FOR THE REFERENCE MEASUREMENT

Band	Frequency (MHz)
3GPP Band 7, TX mid	2535
3GPP Band 7, RX mid	2655
3GPP Band 7, TX high	2570
3GPP Band 7, RX high	2690
3GPP Band 41, TRX low	2496
3GPP Band 41, TRX mid	2593
3GPP Band 41, TRX high	2690
3GPP Band 48, TRX low	3550
3GPP Band 48 TRX mid	3625
3GPP Band 48, TRX high	3700
3GPP Band 46 RX low	5150
3GPP Band 46, RX mid	5537.5
3GPP Band 46, RX high	5925

4.4 Test Procedure

The range reference measurement is performed in a two-step process whereby the effects of the cables and equipment external to the normal operation of the range are removed from the resulting reference values. By performing the measurement in this manner, the measurement uncertainty is reduced, since the result relies on the linearity of the receiver rather than its absolute value accuracy. Additionally, measuring all components of the signal path at once results in only one measurement uncertainty contribution to the total measurement uncertainty of the path loss measurement; as opposed to measuring the loss of each component and combining them for a total loss, which increases the uncertainty by the square root of the number of measurements required.

4.4.1 Measurement Step 1: Source Reference Test (Cable Calibration)

The first step involves measuring the frequency response of all cabling, connectors, and equipment that are not a part of the test system. This step is normally only done once, provided all required test frequencies can be covered with one set of cables. If different cabling configurations are required for each polarization of the reference antenna, etc., this step must be repeated for each configuration. The two steps should be performed sequentially for each configuration to avoid additional uncertainty contributions due to changes in connections, etc.

For each configuration, perform the following steps:

1. Route the source cable(s) from the signal generator or output port of the network analyzer to the mounting location of the reference antenna. A minimum of 3 dB (preferably 10 dB) pad is recommended at the output (reference antenna side) of the cable to minimize standing waves. This output connection is defined as the reference port.
2. Connect the output of the source cable to the receiver or input port of the network analyzer, either directly (if the receiver can be moved to accommodate this connection) or through

another cable (the loopback cable). An additional pad is recommended at the input port of the receiver or at the end of the loopback cable if used.

3. Ensure all equipment has been powered on long enough to have stabilized.
4. Perform a frequency scan or sweep to cover the required test frequencies and record the result. The power level of the signal source must remain fixed for all measurements. Ensure that the received signal is below the compression point of the receiver and any amplifiers or other components in the system (linear region) and sufficiently far above the noise floor of the receiver to account for the expected range path loss. It is recommended that all receivers be set to narrow bandwidth to obtain the lowest possible noise floor. Depending on the equipment used, refer to the following procedure:
 - a. For a vector network analyzer, first record the swept frequency response curve with no calibration applied. This will be used for verifying that the analyzer is in the appropriate linear region (not overloaded) and has enough dynamic range. Perform a calibration of the analyzer to normalize out the response of the cable loop. This calibration will serve as the source reference test. While a full two-port calibration is desirable to provide the lowest measurement uncertainty and account for standing wave issues, etc., flexing of cables, movement of rotary joints, and other variations may make the calibration less accurate in practice. A through response normalization, while having a higher level of uncertainty specified by the manufacturer, may actually be more accurate in practice due to the cable variations involved. Refer to step 5 below for information on estimating these effects.
 - b. For scalar swept frequency devices (scalar network analyzers, spectrum analyzers with tracking generators, etc.) record the swept frequency response curve of the cable loop. If the analyzer contains a scalar calibration or trace math function, it may be used to subtract this reference curve from subsequent measurements.
 - c. For discrete signal generator and receiver combinations, tune the receiver and signal generator to each frequency and record the reading of the receiver.

Note: For swept and list-based measurements using instruments such as network analyzers or spectrum analyzer/tracking generator combinations, care shall be taken to ensure that the measured (received) signal is tracking properly with the transmitted signal to avoid measuring larger losses than the actual path loss. [Appendix N](#) describes this phenomenon in more detail and provides recommended validation procedures.

5. Prior to proceeding to the next test step, move the cables around and monitor the frequency response. Any gross changes in response indicate bad cables or connections and should be rectified prior to continuing. Minor variations (fractions of a dB) are expected and should be accounted for in the measurement uncertainty of the reference measurement.
6. Record the measurement results to a file that can be imported into a Microsoft Excel spreadsheet.

4.4.2 Measurement Step 2: Range Reference Test

The second step measures the frequency response of the reference antenna, range, and all cabling, connectors, switches, etc. between the reference port and the test port, as well as the cabling and equipment included in step 1. This step is required for each polarization of the receive antenna and for each separate signal path between the antenna under test (AUT) and any different test ports connecting to test equipment used for the EUT measurement. Only the paths used to record data (i.e., the paths to the receiver used for TRP measurements, or the output path from the communication tester for TIS measurements) need to be measured.

For each polarization and configuration, perform the following steps:

1. Connect the receiver or input port of the network analyzer to the test port connection to be characterized using the same cable configuration used to attach it to the reference port. Any cable adapters added or removed from the system to make the required connections must be accounted for as mentioned previously. Terminate any unused connections to the appropriate test equipment or by using 50 Ω loads.
2. Prior to connecting the source to the reference antenna, attach a 50 Ω termination to the reference port (or otherwise ensure no output from the signal generator) and record the noise floor of the analyzer or receiver at each frequency point. Use a frequency response sweep or discrete points as necessary based on the configuration. If available, use a max-hold function to obtain the maximum noise level for several sweeps.
3. Connect the reference antenna to the reference port and use a low dielectric support to hold the antenna in the middle of the quiet zone, boresight with the measurement antenna, and parallel to the polarization being characterized. For directional reference antennas, ensure that both the reference and measurement antennas are boresight to each other. Ensure that the support structure is out of the measurement path such that it has a minimal impact on the reference measurement.
4. Ensure all equipment has been powered on long enough to have stabilized. The equipment should normally have been left on from the cable calibration step. All settings of the equipment should be identical to those for the cable calibration. The power level of the signal generator must be the same as that for the reference sweep (unless a vector network analyzer is used to obtain relative power data) and must remain stable over time in order to obtain valid data.
5. Perform a frequency scan or sweep to cover the required test frequencies and record the result. Ensure that the received signal is below the compression point of the receiver (linear region) and at least 20 dB above the noise floor as measured in step 2 above in order to have less than 1 dB measurement uncertainty due to the noise. Depending on the equipment used, refer to the following procedure:
 - a. For a vector network analyzer, record a frequency response curve with the calibration applied. This curve is the desired range response measurement.
 - b. For scalar swept frequency devices (scalar network analyzers, spectrum analyzers with tracking generators, etc.) record the swept frequency response curve of the cable loop. If the analyzer has been configured to automatically subtract the cable calibration reference curve, then the resulting curve is the desired range response measurement. If not, the resulting curve is the range response plus the cable contribution, which will be subtracted out later.
 - c. For discrete signal generator and receiver combinations, tune the receiver and signal generator to each frequency and record the reading of the receiver. The resulting curve is the range response plus the cable contribution, which will be subtracted out later.

Note: For swept and list-based measurements using instruments such as network analyzers or spectrum analyzer/tracking generator combinations, care shall be taken to ensure that the measured (received) signal is tracking properly with the transmitted signal to avoid measuring larger losses than the actual path loss. [Appendix N](#) describes this phenomenon in more detail and provides recommended validation procedures.

6. Record the measurement results to a file that can be imported into a Microsoft Excel spreadsheet.

4.4.3 Calculating the Range Reference Path Loss

Once the data has been acquired as described above, it's necessary to convert it to a loss value and combine it with the reference antenna gain in dBi to obtain the total path loss to be used as the reference correction. Once this value has been determined, it can be added to the power readings of the EUT test equipment to represent the reading relative to an isotropic source.

Use Equation 4.5 to determine the path loss. Table 4-2 shows a sample table for recording the data for one polarization and signal path. For data acquired using calibrated analyzers as described above, the frequency response curve generated by the second measurement is actually $P_{RX} - P_{RX}'$ in dB, so the negative of it represents a loss value. Subtracting that value from the reference antenna gain provides the total path loss. Work backwards as necessary to fill in the columns. Note that with calibration applied, the noise floor reference measurement will also have P_{RX}' subtracted from it. For vector network analyzers, all measured values are relative numbers, so the various reference values will be in dB rather than dBm.

TABLE 4-2 EXAMPLE RANGE REFERENCE MEASUREMENT DATA RECORD

Band	Frequency (MHz)	Cable Ref. (dBm)	Test Port (dBm)	Noise Floor (dBm)	Test Port - Cable (dB)	Test Port - Noise (dB)	Ref. Ant. Gain (dBi)	Path Loss (dB)
3GPP Band 71, TX low	617							
3GPP Band 71, RX low	634.5							
3GPP Band 71, TX mid	652							
3GPP Band 71, RX mid	663							
3GPP Band 71, TX high	680.5							
3GPP Band 71, RX high	698							
3GPP Band 12, TX low	699							
3GPP Band 12, RX low	729							
3GPP Band 12, TX mid	707.5							
3GPP Band 12, RX mid	737.5							
3GPP Band 12, TX high	716							
3GPP Band 12, RX high	746							
3GPP Band 17, TX low	704							
3GPP Band 17, RX low	734							
3GPP Band 17, TX mid	710							
3GPP Band 17, RX mid	734							
3GPP Band 17, TX high	716							
3GPP Band 17, RX high	734							
3GPP Band 29, RX low	717							
3GPP Band 29, RX mid	722.5							
3GPP Band 29, RX high	728							
3GPP Band 13, TX low	777							

TABLE 4-2 EXAMPLE RANGE REFERENCE MEASUREMENT DATA RECORD

Band	Frequency (MHz)	Cable Ref. (dBm)	Test Port (dBm)	Noise Floor (dBm)	Test Port - Cable (dB)	Test Port - Noise (dB)	Ref. Ant. Gain (dBi)	Path Loss (dB)
3GPP Band 13, RX low	746							
3GPP Band 13, TX mid	782							
3GPP Band 13, RX mid	751							
3GPP Band 13, TX high	787							
3GPP Band 13, RX high	756							
3GPP Band 14, TX low	788							
3GPP Band 14, RX low	758							
3GPP Band 14, TX mid	793							
3GPP Band 14, RX mid	763							
3GPP Band 14, TX high	798							
3GPP Band 14, RX high	768							
3GPP Band 26, TX low	814							
3GPP Band 26, RX low	859							
3GPP Band 26, TX mid	831.5							
3GPP Band 26, RX mid	876.5							
3GPP Band 26, TX high	849							
3GPP Band 26, RX high	894							
Cellular (3GPP Band 5), TX low	824	-10.43	-57.78	-99.42	47.35	41.64	1.56	48.91
Cellular (3GPP Band 5), RX low	869	-10.75	-59.46	-101.71	48.71	42.25	1.57	50.28
Cellular (3GPP Band 5), TX mid	836.5	-11.12	-56.61	-98.3	45.49	41.69	1.57	47.06
Cellular (3GPP Band 5), RX mid	881.5	-11.21	-56.48	-97.64	45.27	41.16	1.54	46.81
Cellular (3GPP Band 5), TX high	849	-11.43	-57.57	-99.93	46.14	42.36	1.49	47.63
Cellular (3GPP Band 5), RX high	894	-11.47	-59.44	-96.52	47.97	37.08	1.45	49.42
MBS (M-LMS Band)	925.977							
GPS L1	1575.42							
GLONASS	1602							
PCS (3GPP Band 2), TX low	1850	-15.72	-72.53	-102.42	56.81	29.89	1.85	58.66
PCS (3GPP Band 2), RX low	1930	-15.91	-71.31	-100.9	55.4	29.59	1.88	57.28
PCS (3GPP Band 2), TX mid	1880	-16.2	-70.96	-97.71	54.76	26.75	1.91	56.67
PCS (3GPP Band 2), RX mid	1960	-16.12	-71.25	-103.61	55.13	32.36	1.84	56.97
PCS (3GPP Band 2), TX high	1910	-16.35	-72.75	-102.09	56.4	29.34	1.79	58.19
PCS (3GPP Band 2), RX high	1990	-16.41	-73.41	-98.9	57	25.49	1.71	58.71
3GPP Band 25, TX low	1850							
3GPP Band 25, RX low	1930							
3GPP Band 25, TX mid	1882.5							
3GPP Band 25, RX mid	1962.5							

TABLE 4-2 EXAMPLE RANGE REFERENCE MEASUREMENT DATA RECORD

Band	Frequency (MHz)	Cable Ref. (dBm)	Test Port (dBm)	Noise Floor (dBm)	Test Port - Cable (dB)	Test Port - Noise (dB)	Ref. Ant. Gain (dBi)	Path Loss (dB)
3GPP Band 25, TX high	1915							
3GPP Band 25, RX high	1995							
3GPP Band 70, TX low	1695							
3GPP Band 70, RX low	1995							
3GPP Band 70, TX mid	1702.5							
3GPP Band 70, RX mid	2002.5							
3GPP Band 70, TX high	1710							
3GPP Band 70, RX high	2010							
3GPP Band 70, DL only RX high	2020							
AWS-1 (3GPP Band 4), TX low	1710							
AWS-1 (3GPP Band 4), RX low	2110							
AWS-1 (3GPP Band 4), TX mid	1732.5							
AWS-1 (3GPP Band 4), RX mid	2132.5							
AWS-1 (3GPP Band 4), TX high	1755							
AWS-1 (3GPP Band 4), RX high	2155							
3GPP Band 66, TX low	1710							
3GPP Band 66, RX low	2110							
3GPP Band 66, TX mid	1745							
3GPP Band 66, RX mid	2145							
3GPP Band 66, TX high	1780							
3GPP Band 66, RX high	2180							
3GPP Band 66, DL only RX high	2200							
3GPP Band 30, TX low	2305							
3GPP Band 30, RX low	2350							
3GPP Band 30, TX mid	2310							
3GPP Band 30, RX mid	2355							
3GPP Band 30, TX high	2315							
3GPP Band 30, RX high	2360							
3GPP Band 7, TX low	2500							
3GPP Band 7, RX low	2620							
3GPP Band 7, TX mid	2535							
3GPP Band 7, RX mid	2655							
3GPP Band 7, TX high	2570							
3GPP Band 7, RX high	2690							
3GPP Band 41, TRX low	2496							
3GPP Band 41, TRX mid	2593							

TABLE 4-2 EXAMPLE RANGE REFERENCE MEASUREMENT DATA RECORD

Band	Frequency (MHz)	Cable Ref. (dBm)	Test Port (dBm)	Noise Floor (dBm)	Test Port - Cable (dB)	Test Port - Noise (dB)	Ref. Ant. Gain (dBi)	Path Loss (dB)
3GPP Band 41, TRX high	2690							
3GPP Band 48, TRX low	3550							
3GPP Band 48, TRX mid	3625							
3GPP Band 48, TRX high	3700							
3GPP Band 46, RX low	5150							
3GPP Band 46, RX mid	5537.5							
3GPP Band 46, RX high	5925							

4.5 Range Reference Measurement Data File

Data shall be supplied in a format accessible (i.e. readable) for additional examination and computation as outlined in [Table 4-3](#).

TABLE 4-3 SAMPLE RANGE REFERENCE MEASUREMENT DATA FILE FORMAT

Measurement Date:		May 1, 2003						
Reference Antenna(s):		SD-1234 (Cell Band), SD-4567 (PCS Band)						
Polarization:		Theta						
Signal Path:		Theta Polarization to Spectrum Analyzer (TRP)						
Band	Freq. (MHz)	Cable Ref. (dBm)	Test Port (dBm)	Noise Floor (dBm)	Test Port - Cable (dB)	Test Port - Noise (dB)	Ref. Ant. Gain (dBi)	Path Loss (dB)
Cellular (3GPP Band 5)	824	-10.43	-57.78	-99.42	47.35	41.64	1.56	48.91
Cellular (3GPP Band 5)	836.5	-10.75	-59.46	-101.71	48.71	42.25	1.57	50.28
Cellular (3GPP Band 5)	849	-11.12	-56.61	-98.30	45.49	41.69	1.57	47.06
PCS (3GPP Band 2)	1850	-15.72	-72.53	-102.42	56.81	29.89	1.85	58.66
PCS (3GPP Band 2)	1880	-15.91	-71.31	-100.90	55.40	29.59	1.88	57.28
PCS (3GPP Band 2)	1910	-16.20	-70.96	-97.71	54.76	26.75	1.91	56.67
Polarization:		Phi						
Signal Path:		Phi Polarization to Spectrum Analyzer (TRP)						

TABLE 4-3 SAMPLE RANGE REFERENCE MEASUREMENT DATA FILE FORMAT (CONTINUED)

Band	Freq. (MHz)	Cable Ref. (dBm)	Test Port (dBm)	Noise Floor (dBm)	Test Port - Cable (dB)	Test Port - Noise (dB)	Ref. Ant. Gain (dBi)	Path Loss (dB)
...
Polarization:		Theta						
Signal Path:		Theta Polarization to Communication Tester (TIS)						
Band	Freq. (MHz)	Cable Ref. (dBm)	Test Port (dBm)	Noise Floor (dBm)	Test Port - Cable (dB)	Test Port - Noise (dB)	Ref. Ant. Gain (dBi)	Path Loss (dB)
Cellular (3GPP Band 5)	869	-11.21	-56.48	-97.64	45.27	41.16	1.54	46.81
Cellular (3GPP Band 5)	881.5	-11.43	-57.57	-99.93	46.14	42.36	1.49	47.63
Cellular (3GPP Band 5)	894	-11.47	-59.44	-96.52	47.97	37.08	1.45	49.42
PCS (3GPP Band 2)	1930	-16.12	-71.25	-103.61	55.13	32.36	1.84	56.97
PCS (3GPP Band 2)	1960	-16.35	-72.75	-102.09	56.40	29.34	1.79	58.19
PCS (3GPP Band 2)	1990	-16.41	-73.41	-98.90	57.00	25.49	1.71	58.71
Polarization:		Phi						
Signal Path:		Phi Polarization to Communication Tester (TIS)						
Band	Freq. (MHz)	Cable Ref. (dBm)	Test Port (dBm)	Noise Floor (dBm)	Test Port - Cable (dB)	Test Port - Noise (dB)	Ref. Ant. Gain (dBi)	Path Loss (dB)
...

4.6 Alternate Scenarios

In some cases, it may be desirable to combine the transfer of a precision power calibration (i.e. using a reference power meter) to the measurement equipment along with the range reference measurement into one measurement step. This can have the advantage of reducing the total uncertainty that would be entailed in two separate measurement steps; one to perform the range reference and the second to transfer the power calibration. This section describes two possible scenarios envisioned for performing this type of transfer.

4.6.1 TRP Reference

By using the reference power meter for the reference measurement in step 4 of [Section 4.4.1](#), the absolute power calibration of the reference power meter can be transferred to the measurement receiver used in [Section 4.4.2](#), step 5. The delta between the two measurements now contains not only the path

loss terms of the range reference measurement, but the deviation between the absolute power readings of the two instruments at their relative input levels. Note that this calibration transfer does not account for any non-linearity of the receiver(s) and is most accurate if the power level at the reference antenna is near the power level to be measured in the EUT.

4.6.2 TIS Reference

For TIS measurements, the desired measurement quantity is received power of the EUT at a given error rate. A one-step substitution measurement can be performed (assuming the power sensor can be attached directly to the reference antenna such that no additional cable loss need be accounted for) to transfer a received power calibration to the communication tester along with the range reference measurement. In this case, [Section 4.4.1](#) can be skipped, and the system configured as in [Section 4.4.2](#), with the power sensor now connected to the reference antenna and the communication tester transmitting through the signal path to be qualified. The signal strength is measured out of the reference antenna for a given output level of the base station and the resulting difference becomes the path loss correction for received power. Note that this calibration transfer does not account for any non-linearity of the communication's signal generator or the power meter. Ideally, the source power calibration is most accurate if the power level received at the reference antenna is near the sensitivity level of the EUT, although the sensitivity level of the power meter may have a larger contribution to the overall uncertainty in that case. Note also that the power meter and sensor must be suitable for measuring the active signal generated by the communication tester in order to perform this measurement.

If additional cabling is required to reach the power sensor, that additional cabling is first used to connect the power sensor to the output of the communication tester according to the steps in [Section 4.4.1](#) before proceeding to the steps in [Section 4.4.2](#).

4.6.3 Ripple Based Calibration

Since a single range path loss measurement receives the full error contribution due to any reflections within the test environment (chamber ripple), alternate methods that minimize this error contribution may be used to reduce the measurement uncertainty.

4.7 Wideband Channels

For technologies like WCDMA and LTE, where the channel bandwidths can be several MHz, correcting the path loss at only the center frequency may result in a measurement error when the channel is not perfectly flat. In addition, LTE TRP complicates matters further by offsetting the occupied bandwidth to different portions of the selected channel. Thus, the center frequency of the channel may not even be a frequency that is measured. This error can generally be measured and corrected for by using the power average of the path loss across the occupied bandwidth. The average should be performed on the net path loss, including contributions from all cables, reference antenna gain, and other components to properly capture all standing wave contributions or other factors that would result in a non-flat channel. The calibration data must be taken with sufficient resolution to capture the frequency variation of the channel.

In cases where it is not possible or practical to correct for the average power level in the channel, an additional uncertainty contribution must be included as specified in [Appendix G.22](#). This generally requires a detailed understanding of the channel shape to properly estimate the measurement

uncertainty, making it more practical to correct for the error rather than adding an uncertainty term. In addition, if the average power is not used, the center frequency of the occupied bandwidth should be used. If that is also not possible or practical, then an additional measurement uncertainty term must be applied to address the frequency offset of the correction. Finally, the TIS result does not directly follow the average channel power, but rather is biased higher (worse) due to the portion of the bandwidth that reaches sensitivity first and starts introducing errors. Current indications are that this contribution is small for the channel flatness expected from a typical antenna pattern measurement system, but an appropriate contribution may be estimated as well.

Section 5 Test Procedure—Radiated Power

Unless otherwise noted, all evaluations shall be performed in 'conversational' mode, at maximum transmit power.

Products supporting multiple air-interface technologies shall be tested in accordance with all relevant test procedures. Test results shall be provided for each test performed in the format defined.

It is recommended that one of the two following steps be taken to properly characterize the impact of transmit power drift due to thermal heating.

1. Perform the TRP test concurrently with the TIS test, except for LTE, where different resource block (RB) allocations are used for TRP and TIS.
2. Allow the phone to warm up by turning the transmitter to maximum power for 5 minutes prior to conducting the TRP test.

Please note the following abbreviations in this section:

FS = Free Space

BH = Beside Head (Head Phantom Only)

BHL = Beside Head Left Side (Head Phantom Only)

BHR = Beside Head Right Side (Head Phantom Only)

HL = Hand Left (Hand Phantom Only)

HR = Hand Right (Hand Phantom Only)

BHHL = Beside Head and Hand Left Side (Head and Hand Phantom)

BHHR = Beside Head and Hand Right Side (Head and Hand Phantom)

WL = Wrist-Worn Left (Forearm Phantom)

WR = Wrist-Worn Right (Forearm Phantom)

5.1 AMPS

This section removed for V3.1.

5.2 CDMA

5.2.1 Test Procedure

The measurement site and EUT shall be configured as specified in [Appendix A](#). The power radiated by the EUT shall be measured using a calibrated and accurate RF measuring instrument (e.g., a spectrum analyzer, or measurement receiver, or power meter).

Note: See [Appendix D](#) for power measurement considerations.

The CDMA test parameters shall be set according to TIA-98-E paragraph 4.4.5 for the Maximum RF Output Power test and to the defaults specified in TIA-98-E paragraph 6.5.2 with the exceptions specified in [Table 5-1](#), [Table 5-2](#) or [Table 5-3](#). The Radio Configuration may not be directly settable on certain test boxes. If that is the case, the Radio Configuration will be implicitly set by the Service Option setting. Page the EUT and direct it to a voice/traffic channel. Adjust the Forward Link Power as needed to establish/maintain the voice/traffic channel with an FER such that the transmitter is not gated off during power measurements.

TABLE 5-1 CDMA BASE STATION PARAMETERS—CELLULAR BAND

Parameter	Setting
Type	CDMA
Band Class	0
Channel (Reg.)	As needed ¹
SID	As needed ¹
NID	As needed ¹
Radio Configuration	1
Service Option	2 or 55
Rate	Full
Power Control	Always Up
Path Loss	See Table 4-2
Note 1: Registration channel, SID/NID are service provider-specific.	

TABLE 5-2 CDMA BASE STATION PARAMETERS—PCS BAND

Parameter	Setting
Type	CDMA
Band Class	1
Channel (Reg.)	As needed ¹
SID	As needed ¹
NID	As needed ¹

TABLE 5-2 CDMA BASE STATION PARAMETERS—PCS BAND

Parameter	Setting
Radio Configuration	1
Service Option	2 or 55
Rate	Full
Power Control	Always Up
Path Loss	See Table 4-2
Note 1: Registration channel, SID/NID are service provider-specific.	

TABLE 5-3 CDMA BASE STATION PARAMETERS—AWS-1 BAND

Parameter	Setting
Type	CDMA
Band Class	15
Channel (Reg.)	As needed ¹
SID	As needed ¹
NID	As needed ¹
Radio Configuration	1
Service Option	2 or 55
Rate	Full
Power Control	Always Up
Path Loss	See Table 4-2
Note 1: Registration channel, SID/NID are service provider-specific.	

Tests shall be carried out for three different frequency pairs across the bands supported by the EUT (i.e., cellular, PCS and/or AWS-1), as defined in [Table 5-4](#).

TABLE 5-4 CDMA TEST FREQUENCIES

Band	Channel Pair	Frequency (MHz)
CDMA 800 (Cellular)	1013	824.7
	1013	869.7
	384	836.52
	384	881.52
	777	848.31
	777	893.31

TABLE 5-4 CDMA TEST FREQUENCIES

Band	Channel Pair	Frequency (MHz)
CDMA 1900 (PCS)	25	1851.25
	25	1931.25
	600	1880.00
	600	1960.00
	1175	1908.75
	1175	1988.75
CDMA 2100/1700 (AWS-1)	25	1711.25
	25	2111.25
	450	1732.5
	450	2132.5
	875	1753.75
	875	2153.75

Head and hand phantom, hand phantom only and/or free-space testing shall be conducted based on device type, as specified in [Appendix O](#). Refer to [Appendix C](#) for head/hand testing requirements. Perform each test on all specified frequencies with the EUT antenna extended and retracted, as applicable.

5.2.2 Criteria

Results shall be reported as specified in [Appendix B](#) using the figures of merit given in [Appendix B.3](#). [Appendix B.1](#) contains the pass/fail OTA tables for CDMA. Reports shall include results for free-space and head/hand configurations (if applicable) across all channels measured with the EUT antenna extended and retracted (if applicable).

TABLE 5-5 CDMA MINIMUM TRP LEVEL (IN DBM) REQUIREMENTS FOR THE PRIMARY MECHANICAL MODE¹

Band	Device Held Up to Head for Voice (Yes/No)	Antenna Type	Device Power Class	Device Width (mm) ²	FS	BHHL and BHHR	HL and HR
CDMA 800	Yes ³	Embedded	I	≤72	25	TBD	TBD
				>72	25	TBD	TBD
			II	≤72	22	TBD	TBD
				>72	22	TBD	TBD
			III	≤72	18	TBD	TBD
				>72	18	TBD	TBD
		Stub or Retractable	I	≤72	27	TBD	TBD
				>72	27	TBD	TBD
			II	≤72	24	TBD	TBD
				>72	24	TBD	TBD
	III		≤72	20	TBD	TBD	
		>72	20	TBD	TBD		
	No ⁴	All	I	All	27	N/A	N/A
			II	All	24	N/A	N/A
			III	All	20	N/A	N/A

TABLE 5-5 CDMA MINIMUM TRP LEVEL (IN DBM) REQUIREMENTS FOR THE PRIMARY MECHANICAL MODE¹

Band	Device Held Up to Head for Voice (Yes/No)	Antenna Type	Device Power Class	Device Width (mm) ²	FS	BHHL and BHR	HL and HR
CDMA 1900	Yes ³	Embedded	I	≤72	23	TBD	TBD
			I	>72	23	TBD	TBD
			II	≤72	18	TBD	TBD
			II	>72	18	TBD	TBD
			III	≤72	13	TBD	TBD
			III	>72	13	TBD	TBD
			IV	≤72	8	TBD	TBD
			IV	>72	8	TBD	TBD
			V	≤72	3	TBD	TBD
		V	>72	3	TBD	TBD	
		Stub or Retractable	I	≤72	25	TBD	TBD
			I	>72	25	TBD	TBD
			II	≤72	20	TBD	TBD
			II	>72	20	TBD	TBD
			III	≤72	15	TBD	TBD
			III	>72	15	TBD	TBD
			IV	≤72	10	TBD	TBD
			IV	>72	10	TBD	TBD
	V		≤72	5	TBD	TBD	
	V	>72	5	TBD	TBD		
	No ⁴	All	I	All	25	N/A	N/A
			II	All	20	N/A	N/A
			III	All	15	N/A	N/A
			IV	All	10	N/A	N/A
			V	All	5	N/A	N/A

TABLE 5-5 CDMA MINIMUM TRP LEVEL (IN DBM) REQUIREMENTS FOR THE PRIMARY MECHANICAL MODE¹

Band	Device Held Up to Head for Voice (Yes/No)	Antenna Type	Device Power Class	Device Width (mm) ²	FS	BHHL and BHHR	HL and HR
CDMA 2100/1700	Yes ³	Embedded	I	≤72	22	TBD	TBD
			I	>72	22	TBD	TBD
			II	≤72	17	TBD	TBD
			II	>72	17	TBD	TBD
			III	≤72	12	TBD	TBD
			III	>72	12	TBD	TBD
			IV	≤72	7	TBD	TBD
			IV	>72	7	TBD	TBD
			V	≤72	2	TBD	TBD
		V	>72	2	TBD	TBD	
		Stub or Retractable	I	≤72	22	TBD	TBD
			I	>72	22	TBD	TBD
			II	≤72	17	TBD	TBD
			II	>72	17	TBD	TBD
			III	≤72	12	TBD	TBD
			III	>72	12	TBD	TBD
			IV	≤72	7	TBD	TBD
			IV	>72	7	TBD	TBD
	V		≤72	2	TBD	TBD	
	No ⁴	All	I	All	22	N/A	N/A
II			All	17	N/A	N/A	
III			All	12	N/A	N/A	
IV			All	7	N/A	N/A	
V			All	2	N/A	N/A	

Note 1: Primary Mechanical Mode refers to device configured in preferred mode per manufacturer instructions (typically means antenna extended, fold or portrait slide open, but depends on form factor).

Note 2: Differences between requirements for devices wider and narrower than 72 mm reflect observed differences in OTA performance with different hand phantoms of up to 6 dB.

Note 3: "Yes" applies if the device supports voice operation in the talking position against the head in any cellular radio mode.

Note 4: "No" would be applicable to data-centric devices that are not held up against the head, e.g., embedded laptop solutions.

5.3 TDMA

This section removed for V3.1.

5.4 GSM

5.4.1 Test Procedure

The measurement site and EUT shall be configured as specified in Appendix A. The power radiated by the EUT shall be measured using a calibrated and accurate RF measuring instrument (e.g., a spectrum analyzer, measurement receiver, or power meter) capable of averaging across bursts.

Note: See [Appendix D](#) for power measurement considerations.

Using the settings in [Table 5-6](#) or [Table 5-7](#), page the EUT and direct it to a voice/traffic channel.

TABLE 5-6 PCL SETTING FOR GSM 850

Device Class	Setting
2	2
3	3
4	5
5	7

TABLE 5-7 PCL SETTING FOR GSM 1900

Device Class	Setting
1	0
2	3
3	30

Tests shall be performed for three different channels across the bands supported by the EUT, as defined in [Table 5-8](#).

TABLE 5-8 GSM RX AND TX TEST FREQUENCIES

Band	Channel Pair	Frequency (MHz)
GSM 850 (Cellular)	128	824.20
	128	869.20
	190	836.60
	190	881.60
	251	848.80
	251	893.80
GSM 1900 (PCS)	512	1850.20
	512	1930.20
	661	1880.00
	661	1960.00
	810	1909.80
	810	1989.80

Head and hand phantom, hand phantom only and/or free-space testing shall be conducted based on device type, as specified in [Appendix O](#). Refer to [Appendix C](#) for head/hand testing requirements. Perform each test on all specified frequencies with the EUT antenna extended and retracted, as applicable.

5.4.2 Criteria

Results shall be reported as specified in [Appendix B](#) using the figures of merit given in [Appendix B.3](#). [Appendix B.1](#) contains the pass/fail OTA tables for GSM. Reports shall include results for free-space and head/hand configurations (if applicable) across all channels measured with the EUT antenna extended and retracted (if applicable).

The limits in Table 5-9 are recommended.

TABLE 5-9 GSM MINIMUM TRP LEVEL (IN dBm) RECOMMENDED LIMITS FOR THE PRIMARY MECHANICAL MODE¹

Band	Device Held Up to Head for Voice (Yes/No)	Device Power Class	Device Width (mm) ²	FS	BHHL and BHHR	HL and HR ³	
GSM 850	Yes ⁴	2	≤72	32	TBD	N/A	
		2	>72	32	TBD	N/A	
		3	≤72	30	TBD	N/A	
		3	>72	30	TBD	N/A	
		4	≤72	26	TBD	N/A	
		4	>72	26	TBD	N/A	
		5	≤72	22	TBD	N/A	
		5	>72	22	TBD	N/A	
	No ⁵	2	All	32	N/A	N/A	
		3	All	30	N/A	N/A	
		4	All	26	N/A	N/A	
		5	All	22	N/A	N/A	
	GSM 1900	Yes ⁴	1	≤72	24.5	TBD	N/A
			1	>72	24.5	TBD	N/A
2			≤72	18.5	TBD	N/A	
2			>72	18.5	TBD	N/A	
3			≤72	27.5	TBD	N/A	
3			>72	27.5	TBD	N/A	
No ⁵		1	All	24.5	N/A	N/A	
		2	All	18.5	N/A	N/A	
		3	All	27.5	N/A	N/A	
		3	All	27.5	N/A	N/A	

Note 1: Primary Mechanical Mode refers to device configured in preferred mode per manufacturer instructions (typically means antenna extended, fold or portrait slide open, but depends on form factor).
 Note 2: Differences between requirements for devices wider and narrower than 72 mm reflect observed differences in OTA performance with different hand phantoms of up to 6 dB.
 Note 3: GSM HL and HR tests are optional and are currently not a requirement of this Test Plan, but may be used for single and multiple offset point reference tests including GPRS/EGPRS.
 Note 4: “Yes” applies if the device supports voice operation in the talking position against the head in any cellular radio mode.
 Note 5: “No” would be applicable to data-centric devices that are not held up against the head, e.g., embedded laptop solutions.

Note: Device Power shall comply with the power levels specified in the relevant industry standard(s).



5.5 GPRS

5.5.1 Test Procedure

The measurement site and EUT shall be configured as specified in [Appendix A](#). The power radiated by the EUT shall be measured using a calibrated and accurate RF measuring instrument (e.g., a spectrum analyzer, measurement receiver, or power meter) capable of averaging across bursts.

Note: See [Appendix D](#) for power measurement considerations.

Using the settings in [Table 5-10](#), [Table 5-11](#) and [Table 5-12](#); establish a GPRS data loopback session between the EUT and a GPRS-capable base station simulator. Configure the GPRS base station simulator to direct the EUT to an appropriate packet traffic channel. During this test, the maximum number of uplink time slots supported by the EUT shall be utilized, and the uplink coding scheme should be CS-1.

TABLE 5-10 PCL AND GAMMA SETTING FOR GMSK MODULATION IN GSM 850 BAND

Device Class	PCL Setting	Gamma Setting
2	2	0
3	3	1
4	5	3
5	7	5

TABLE 5-11 PCL AND GAMMA SETTING FOR GMSK MODULATION IN GSM 1900 BAND

Device Class	PCL Setting	Gamma Setting
1	0	3
2	3	6
3	30	1

TABLE 5-12 CODING SCHEME (CS) SETTING FOR GMSK MODULATION IN EITHER GSM 850 OR GSM 1900 BAND

CS
1

Coding scheme CS-1 is the preferred setting for TRP measurements, as this provides the most robust channel coding to maintain the data loopback session. Coding schemes CS-2 through CS-4 can be utilized for TRP measurements only.

Tests shall be performed for three different channels across the bands supported by the EUT, as defined in [Table 5-8](#).

Head and hand phantom, hand phantom only and/or free-space testing shall be conducted based on device type, as specified in [Appendix O](#). Refer to [Appendix C](#) for head/hand testing requirements. Perform each test on all specified frequencies with the EUT antenna extended and retracted, as applicable.

Note: Head-adjacent testing is only required for GPRS if the EUT supports usage against the head in this mode (e.g., VoIP).

5.5.2 Criteria

Results shall be reported as specified in [Appendix B](#) using the figures of merit given in [Appendix B.3](#). [Appendix B.1](#) contains the pass/fail OTA tables for GPRS. Reports shall include results for free-space and head/hand configurations (if applicable) across all channels measured with the EUT antenna extended and retracted (if applicable).

The limits in [Table 5-13](#) are recommended.

TABLE 5-13 GPRS MINIMUM TRP LEVEL (IN DBM) RECOMMENDED LIMITS FOR THE PRIMARY MECHANICAL MODE^{1 2}

Band	Device Held Up to Head for Voice (Yes/No)	Device Power Class	Device Width (mm) ³	FS	BHHL and BHR	HL and HR
GPRS 850	Yes ⁴	2	≤72	32	TBD	TBD
		2	>72	32	TBD	TBD
		3	≤72	30	TBD	TBD
		3	>72	30	TBD	TBD
		4	≤72	26	TBD	TBD
		4	>72	26	TBD	TBD
		5	≤72	22	TBD	TBD
		5	>72	22	TBD	TBD
	No ⁵	2	All	32	N/A	N/A
		3	All	30	N/A	N/A
		4	All	26	N/A	N/A
		5	All	22	N/A	N/A

TABLE 5-13 GPRS MINIMUM TRP LEVEL (IN DBM) RECOMMENDED LIMITS FOR THE PRIMARY MECHANICAL MODE^{1 2}

Band	Device Held Up to Head for Voice (Yes/No)	Device Power Class	Device Width (mm) ³	FS	BHHL and BHHR	HL and HR
GPRS 1900	Yes ⁴	1	≤72	24.5	TBD	TBD
		1	>72	24.5	TBD	TBD
		2	≤72	18.5	TBD	TBD
		2	>72	18.5	TBD	TBD
		3	≤72	27.5	TBD	TBD
		3	>72	27.5	TBD	TBD
	No ⁵	1	All	24.5	N/A	N/A
		2	All	18.5	N/A	N/A
		3	All	27.5	N/A	N/A

Note 1: Primary Mechanical Mode refers to device configured in preferred mode per manufacturer instructions (typically means antenna extended, fold or portrait slide open, but depends on form factor).

Note 2: The associated TRP value is based on measurements made with one uplink slot. Devices tested using two uplink time slots are allowed a TRP reduction of 3 dB, devices tested using three uplink slots are allowed a TRP reduction of up to 4.8 dB and devices tested using four uplink slots are allowed a TRP reduction of up to 6 dB. These allowances for uplink slot counts greater than one are based on an EUT capable of meeting the minimum TRP performance in single slot operation. This allowance is in alignment with 3GPP TS 45.005, Section 4.1.1, Table 4.1-5.

Note 3: Differences between requirements for devices wider and narrower than 72 mm reflect observed differences in OTA performance with different hand phantoms of up to 6 dB.

Note 4: "Yes" applies if the device supports voice operation in the talking position against the head in any cellular radio mode.

Note 5: "No" would be applicable to data-centric devices that are not held up against the head, e.g., embedded laptop solutions.

Note: Device Power shall comply with the power levels specified in the relevant industry standard(s).

5.6 EGPRS

5.6.1 Test Procedure

The measurement site and EUT shall be configured as specified in [Appendix A](#). The power radiated by the EUT shall be measured using a calibrated and accurate RF measuring instrument (e.g., a spectrum analyzer, measurement receiver, or power meter) capable of averaging across bursts.

Note: See [Appendix D](#) for power measurement considerations.

Using the settings in [Table 5-14](#), [Table 5-15](#) and [Table 5-16](#); initiate a data loopback session between the EUT and an EGPRS-capable base station simulator. Configure the EGPRS base station simulator to

direct the EUT to an appropriate packet traffic channel. During this test, the maximum uplink time slots supported by the EUT shall be utilized, and the uplink coding scheme should be MCS-5.

TABLE 5-14 PCL AND GAMMA SETTING FOR 8-PSK MODULATION (EDGE) IN GSM 850 BAND

Device Class	PCL Setting	Gamma Setting
E1	5	3
E2	8	6
E3	10	8

TABLE 5-15 PCL AND GAMMA SETTING FOR 8-PSK MODULATION (EDGE) IN GSM 1900 BAND

Device Class	PCL Setting	Gamma Setting
E1	0	3
E2	2	5
E3	4	7

TABLE 5-16 MODULATION CODING SCHEME (MCS) SETTING FOR 8-PSK MODULATION (EDGE) IN EITHER GSM 850 OR GSM 1900 BAND

MCS
5

Modulation coding scheme MCS 5 is the preferred setting for TRP measurements, as this provides the most robust channel coding to maintain the data session. MCS 6 through MSC 9 can be utilized for TRP measurements only.

Tests shall be performed for three different channels across the bands supported by the EUT, as defined in [Table 5-8](#).

Head and hand phantom, hand phantom only and/or free-space testing shall be conducted based on device type, as specified in [Appendix O](#). Refer to [Appendix C](#) for head/hand testing requirements. Perform each test on all specified frequencies with the EUT antenna extended and retracted, as applicable.

Note: Head-adjacent testing is only required for EGPRS if the EUT supports usage against the head in this mode (e.g., VoIP).

5.6.2 Criteria

Results shall be reported as specified in [Appendix B](#) using the figures of merit given in [Appendix B.3](#). [Appendix B.1](#) contains the pass/fail OTA tables for EGPRS. Reports shall include results for free-space and head/hand configurations (if applicable) across all channels measured with the EUT antenna extended and retracted (if applicable).

The limits in Table 5-17 are recommended.

TABLE 5-17 EGPRS MINIMUM TRP LEVEL (IN DBM) RECOMMENDED LIMITS FOR THE PRIMARY MECHANICAL MODE^{1,2}

Band	Device Held Up to Head for Voice (Yes/No)	Device Power Class	Device Width (mm) ³	FS	BHHL and BHHR	HL and HR
EGPRS 850	Yes ⁴	E1	≤72	26	TBD	TBD
		E1	>72	26	TBD	TBD
		E2	≤72	20	TBD	TBD
		E2	>72	20	TBD	TBD
		E3	≤72	16	TBD	TBD
		E3	>72	16	TBD	TBD
	No ⁵	E1	All	26	N/A	N/A
		E2	All	20	N/A	N/A
		E3	All	16	N/A	N/A
EGPRS 1900	Yes ⁴	E1	≤72	24.5	TBD	TBD
		E1	>72	24.5	TBD	TBD
		E2	≤72	20.5	TBD	TBD
		E2	>72	20.5	TBD	TBD
		E3	≤72	16.5	TBD	TBD
		E3	>72	16.5	TBD	TBD
	No ⁵	E1	All	24.5	N/A	N/A
		E2	All	20.5	N/A	N/A
		E3	All	16.5	N/A	N/A

Note 1: Primary Mechanical Mode refers to device configured in preferred mode per manufacturer instructions (typically means antenna extended, fold or portrait slide open, but depends on form factor).

Note 2: The associated TRP value is based on measurements made with one or two uplink slots. Devices tested using three uplink slots are allowed a TRP reduction of up to 1.8 dB and devices tested using four uplink slots are allowed a TRP reduction of up to 3 dB. These allowances for uplink slot counts greater than two are based on an EUT capable of meeting the minimum TRP performance in single or dual-slot operation.

Note 3: Differences between requirements for devices wider and narrower than 72 mm reflect observed differences in OTA performance with different hand phantoms of up to 6 dB.

Note 4: "Yes" applies if the device supports voice operation in the talking position against the head in any cellular radio mode.

Note 5: "No" would be applicable to data-centric devices that are not held up against the head, e.g., embedded laptop solutions.

Note: Device Power shall comply with the power levels specified in the relevant industry standard(s).

5.7 UMTS (WCDMA)

5.7.1 Test Procedure

The measurement site and EUT shall be configured as specified in [Appendix A](#). The power radiated by the EUT shall be measured using a calibrated and accurate RF measuring instrument (e.g., a spectrum analyzer, or measurement receiver, or power meter).

Note: See [Appendix D](#) for power measurement considerations.

The UMTS system simulator shall be set up according to 3GPP TS 34.121-1, Section 5.2 (Maximum Output Power test) using the defaults specified in 3GPP TS 34.121-1, 3GPP TS 34.108 and 3GPP TS 34.109, as applicable. Using the Generic Call Setup procedures described in 3GPP TS 34.108 Section 7, page the EUT and place it into the loopback mode as described in 3GPP TS 34.109 Section 5.3. During this test, ensure that the System Simulator is continuously sending “up power” commands as described in 3GPP TS 34.121-1, Section 5.2.4.2.

Tests shall be performed for three different channels across the bands supported by the EUT, as defined in [Table 5-18](#).

TABLE 5-18 UMTS RX AND TX TEST FREQUENCIES

Band	Channel Pair (UARFCN)	Frequency (MHz)
UMTS 850 (3GPP BAND V)	4132	826.40
	4357	871.40
	4183	836.60
	4408	881.60
	4233	846.60
	4458	891.60
UMTS 1900 (3GPP BAND II)	9262	1852.40
	9662	1932.40
	9400	1880.00
	9800	1960.00
	9538	1907.60
	9938	1987.60
UMTS 2100/1700 (3GPP BAND IV)	1312	1712.40
	1537	2112.40
	1413	1732.60
	1638	2132.60
	1513	1752.60
	1738	2152.60

Head and hand phantom, hand phantom only and/or free-space testing shall be conducted based on device type, as specified in [Appendix O](#). Refer to [Appendix C](#) for head/hand testing requirements. Perform each test on all specified frequencies with the EUT antenna extended and retracted, as applicable.

5.7.2 Criteria

Results shall be reported as specified in [Appendix B](#) using the figures of merit given in [Appendix B.3](#). [Appendix B.1](#) contains the pass/fail OTA tables for UMTS. Reports shall include results for free-space and head/hand configurations (if applicable) across all channels measured with the EUT antenna extended and retracted (if applicable).

The limits in [Table 5-19](#) are recommended.

TABLE 5-19 UMTS MINIMUM TRP LEVEL (IN DBM) RECOMMENDED LIMITS FOR THE PRIMARY MECHANICAL MODE¹

Band	Device Held Up to Head for Voice (Yes/No)	Device Power Class	Device Width (mm) ²	FS	BHHL and BHHR	HL and HR
UMTS 850	Yes ³	3	≤72	17	TBD	TBD
		3	>72	17	TBD	TBD
		4	≤72	14	TBD	TBD
		4	>72	14	TBD	TBD
	No ⁴	3	All	17	N/A	N/A
		4	All	14	N/A	N/A
UMTS 1900	Yes ³	3	≤72	18.5	TBD	TBD
		3	>72	18.5	TBD	TBD
		4	≤72	15.5	TBD	TBD
		4	>72	15.5	TBD	TBD
	No ⁴	3	All	18.5	N/A	N/A
		4	All	15.5	N/A	N/A

TABLE 5-19 UMTS MINIMUM TRP LEVEL (IN dBm) RECOMMENDED LIMITS FOR THE PRIMARY MECHANICAL MODE¹

Band	Device Held Up to Head for Voice (Yes/No)	Device Power Class	Device Width (mm) ²	FS	BHHL and BHHR	HL and HR
UMTS 2100/ 1700	Yes ³	3	≤72	19.5	TBD	TBD
		3	>72	19.5	TBD	TBD
		4	≤72	16.5	TBD	TBD
		4	>72	16.5	TBD	TBD
	No ⁴	3	All	19.5	N/A	N/A
		4	All	16.5	N/A	N/A
<p>Note 1: Primary Mechanical Mode refers to device configured in preferred mode per manufacturer instructions (typically means antenna extended, fold or portrait slide open, but depends on form factor).</p> <p>Note 2: Differences between requirements for devices wider and narrower than 72 mm reflect observed differences in OTA performance with different hand phantoms of up to 6 dB.</p> <p>Note 3: "Yes" applies if the device supports voice operation in the talking position against the head in any cellular radio mode.</p> <p>Note 4: "No" would be applicable to data-centric devices that are not held up against the head, e.g., embedded laptop solutions.</p>						

Note: Device Power shall comply with the power levels specified in the relevant industry standard(s).

5.8 LTE

5.8.1 Test Procedure

The measurement site and EUT shall be configured as specified in [Appendix A](#). The power radiated by the EUT shall be measured using a calibrated and accurate RF measuring instrument (e.g., a spectrum analyzer, or measurement receiver, or power meter).

Note: See [Appendix D](#) for power measurement considerations.

The LTE system simulator and EUT shall be configured per 3GPP TS 36.521-1, Section 6.2 (UE Maximum Output Power) using the default settings specified in 3GPP TS 36.521-1 and 3GPP TS 36.508 as applicable. The test procedure in section 6.2 of 3GPP TS 36.521-1 shall be used to measure the UE output power. When a UE operates in Power Class 1, the IE (Information Element) p-Max must be included and set according to Table 6.2.2_1.4-2 of TS 36.521-1. Otherwise, p-Max shall not be signaled during attach procedures or during measurements.

Tests shall be carried out for different frequency pairs (FDD; UL -uplink /DL -downlink) or frequencies (TDD) and RB allocations across the bands supported by the EUT, as defined in [Table 5-20](#).

TABLE 5-20 LTE TRP MEASUREMENTS TABLE FOR THE PRIMARY MECHANICAL MODE¹

Band	Channel Bandwidth (MHz)	Channel	TX Frequency (MHz) [center of UL RB allocation]	UL RB Allocation	DL RB Allocation
2 ²	10	18650	1851.58	12 RB with RBstart=0	N/A ³
	10	18900	1880	12 RB with RBstart=19	N/A ³
	10	19150	1908.42	12 RB with RBstart=38	N/A ³
4 ⁴	10	20000	1711.58	12 RB with RBstart=0	N/A ³
	10	20175	1732.5	12 RB with RBstart=19	N/A ³
	10	20350	1753.42	12 RB with RBstart=38	N/A ³
5 ⁵	10	20450	825.58	12 RB with RBstart=0	N/A ³
	10	20525	836.5	12 RB with RBstart=19	N/A ³
	10	20600	847.42	12 RB with RBstart=38	N/A ³
7	20	20850	2502.62	18 RB with RBstart=0	N/A ³
	20	21100	2535	18 RB with RBstart=41	N/A ³
	20	21350	2567.38	18 RB with RBstart=82	N/A ³
12 ⁶	5	23035	699.97	8 RB with RBstart=0	N/A ³
	5	23095	707.41	8 RB with RBstart=8	N/A ³
	5	23155	715.03	8 RB with RBstart=17	N/A ³

TABLE 5-20 LTE TRP MEASUREMENTS TABLE FOR THE PRIMARY MECHANICAL MODE¹

Band	Channel Bandwidth (MHz)	Channel	TX Frequency (MHz) [center of UL RB allocation]	UL RB Allocation	DL RB Allocation
13	10	23230	778.58	12 RB with RBstart=0	N/A ³
	10	23230	782	12 RB with RBstart=19	N/A ³
	10	23230	785.42	12 RB with RBstart=38	N/A ³
14	10	23330	789.58	12 RB with RBstart=0	N/A ³
	10	23330	793	12 RB with RBstart=19	N/A ³
	10	23330	796.42	12 RB with RBstart=38	N/A ³
17 ⁶	10	23780	705.58	12 RB with RBstart=0	N/A ³
	10	23790	710	12 RB with RBstart=19	N/A ³
	10	23800	714.42	12 RB with RBstart=38	N/A ³
25 ²	5	26065	1850.97	8 RB with RBstart=0	N/A ³
	5	26365	1882.41	8 RB with RBstart=8	N/A ³
	5	26665	1914.03	8 RB with RBstart=17	N/A ³
26 ⁵	5	26715	814.97	8 RB with RBstart=0	N/A ³
	5	26865	831.41	8 RB with RBstart=8	N/A ³
	5	27015	848.03	8 RB with RBstart=17	N/A ³
30	10	27710	2306.58	12 RB with RBstart=0	N/A ³
	10	27710	2310	12 RB with RBstart=19	N/A ³
	10	27710	2313.42	12 RB with RBstart=38	N/A ³
41	20	39750	2498.62	18 RB with RBstart=0	N/A ³
	20	40620	2593	18 RB with RBstart=41	N/A ³
	20	41490	2687.38	18 RB with RBstart=82	N/A ³
48	10	55290	3551.58	12 RB with RBstart=0	N/A ³
	10	55990	3625	12 RB with RBstart=19	N/A ³
	10	56690	3698.42	12 RB with RBstart=38	N/A ³
66 ⁴	10	132022	1711.58	12 RB with RBstart=0	N/A ³
	10	132322	1745	12 RB with RBstart=19	N/A ³
	10	132622	1778.42	12 RB with RBstart=38	N/A ³
70	15	133047	1697.19	16 RB with RBstart=0	N/A ³
	15	133047	1702.41	16 RB with RBstart=29	N/A ³
	15	133047	1707.81	16 RB with RBstart=59	N/A ³

TABLE 5-20 LTE TRP MEASUREMENTS TABLE FOR THE PRIMARY MECHANICAL MODE¹

Band	Channel Bandwidth (MHz)	Channel	TX Frequency (MHz) [center of UL RB allocation]	UL RB Allocation	DL RB Allocation
71	10	133172	664.58	12 RB with RBstart=0	N/A ³
	10	133297	680.5	12 RB with RBstart=19	N/A ³
	10	133422	696.42	12 RB with RBstart=38	N/A ³
<p>Note 1: Primary Mechanical Mode refers to device configured in preferred mode per manufacturer instructions (typically means antenna extended, fold or portrait slide open, but depends on form factor).</p> <p>Note 2: If the device supports Band 25 and Band 2, then testing is only required to be completed in Band 25. The test requirements and data comparison between Bands 2 and 25 will not be directly comparable due to the usage of different RF channel bandwidths.</p> <p>Note 3: As per 3GPP TS 36.521-1, Section 6.2 (UE Maximum Output Power).</p> <p>Note 4: If the device supports Band 4 and Band 66, then testing is only required to be completed in Band 66.</p> <p>Note 5: If the device supports Band 26 and Band 5, then testing is only required to be completed in Band 26. The test requirements and data comparison between Bands 5 and 26 will not be directly comparable due to the usage of different RF channel bandwidths.</p> <p>Note 6: If the device supports Band 12 and Band 17, then testing is only required to be completed in Band 12. The test requirements and data comparison between Bands 12 and 17 will not be directly comparable due to the usage of different RF channel bandwidths.</p>					

Head and hand phantom, hand phantom only and/or free-space testing shall be conducted based on device type, as specified in [Appendix O](#). Refer to [Appendix C](#) for head/hand testing requirements. Perform each test on all specified frequencies and RB allocations with the EUT antenna extended and retracted, as applicable.

Note: Head-adjacent testing is only required for LTE if the EUT supports usage against the head while utilizing an LTE airlink (e.g., VoIP).

5.8.2 Criteria

Results shall be reported as specified in [Appendix B](#) using the figures of merit given in [Appendix B.3](#). [Appendix B.1](#) contains the pass/fail OTA tables for LTE. Reports shall include results for applicable use cases, including free-space, head/hand configurations and/or wrist-worn configurations, across all channels and RB allocations measured with the EUT in primary mechanical mode, and (if applicable) in non-primary mechanical modes as reference information.

TABLE 5-21 LTE MINIMUM TRP LEVEL (IN dBm) REQUIREMENTS FOR THE PRIMARY MECHANICAL MODE¹

Band	Use Cases Supported	Device Width (mm) ²	Free Space	WL and WR	BHHL and BHHR	HL and HR
LTE Band 71	Held to head for voice ³	≤72	TBD	N/A	TBD	TBD
		>72	TBD	N/A	TBD	TBD
	Wrist-worn ⁴	All	N/A	TBD	N/A	N/A
	Other ⁵	All	TBD	N/A	N/A	N/A
LTE Band 12	Held to head for voice ³	≤72	TBD	N/A	TBD	TBD
		>72	TBD	N/A	TBD	TBD
	Wrist-worn ⁴	All	N/A	TBD	N/A	N/A
	Other ⁵	All	TBD	N/A	N/A	N/A
LTE Band 17	Held to head for voice ³	≤72	TBD	N/A	TBD	TBD
		>72	TBD	N/A	TBD	TBD
	Wrist-worn ⁴	All	N/A	TBD	N/A	N/A
	Other ⁵	All	TBD	N/A	N/A	N/A
LTE Band 13	Held to head for voice ³	≤72	TBD	N/A	TBD	TBD
		>72	TBD	N/A	TBD	TBD
	Wrist-worn ⁴	All	N/A	TBD	N/A	N/A
	Other ⁵	All	TBD	N/A	N/A	N/A
LTE Band 14	Held to head for voice ³	≤72	TBD	N/A	TBD	TBD
		>72	TBD	N/A	TBD	TBD
	Wrist-worn ⁴	All	N/A	TBD	N/A	N/A
	Other ⁵	All	TBD	N/A	N/A	N/A
LTE Band 26	Held to head for voice ³	≤72	TBD	N/A	TBD	TBD
		>72	TBD	N/A	TBD	TBD
	Wrist-worn ⁴	All	N/A	TBD	N/A	N/A
	Other ⁵	All	TBD	N/A	N/A	N/A
LTE Band 5	Held to head for voice ³	≤72	TBD	N/A	TBD	TBD
		>72	TBD	N/A	TBD	TBD
	Wrist-worn ⁴	All	N/A	TBD	N/A	N/A
	Other ⁵	All	TBD	N/A	N/A	N/A
LTE Band 70	Held to head for voice ³	≤72	TBD	N/A	TBD	TBD
		>72	TBD	N/A	TBD	TBD
	Wrist-worn ⁴	All	N/A	TBD	N/A	N/A
	Other ⁵	All	TBD	N/A	N/A	N/A

TABLE 5-21 LTE MINIMUM TRP LEVEL (IN dBm) REQUIREMENTS FOR THE PRIMARY MECHANICAL MODE¹

Band	Use Cases Supported	Device Width (mm) ²	Free Space	WL and WR	BHHL and BHRH	HL and HR
LTE Band 2	Held to head for voice ³	≤72	TBD	N/A	TBD	TBD
		>72	TBD	N/A	TBD	TBD
	Wrist-worn ⁴	All	N/A	TBD	N/A	N/A
	Other ⁵	All	TBD	N/A	N/A	N/A
LTE Band 25	Held to head for voice ³	≤72	TBD	N/A	TBD	TBD
		>72	TBD	N/A	TBD	TBD
	Wrist-worn ⁴	All	N/A	TBD	N/A	N/A
	Other ⁵	All	TBD	N/A	N/A	N/A
LTE Band 4	Held to head for voice ³	≤72	TBD	N/A	TBD	TBD
		>72	TBD	N/A	TBD	TBD
	Wrist-worn ⁴	All	N/A	TBD	N/A	N/A
	Other ⁵	All	TBD	N/A	N/A	N/A
LTE Band 66	Held to head for voice ³	≤72	TBD	N/A	TBD	TBD
		>72	TBD	N/A	TBD	TBD
	Wrist-worn ⁴	All	N/A	TBD	N/A	N/A
	Other ⁵	All	TBD	N/A	N/A	N/A
LTE Band 30	Held to head for voice ³	≤72	TBD	N/A	TBD	TBD
		>72	TBD	N/A	TBD	TBD
	Wrist-worn ⁴	All	N/A	TBD	N/A	N/A
	Other ⁵	All	TBD	N/A	N/A	N/A
LTE Band 7	Held to head for voice ³	≤72	TBD	N/A	TBD	TBD
		>72	TBD	N/A	TBD	TBD
	Wrist-worn ⁴	All	N/A	TBD	N/A	N/A
	Other ⁵	All	TBD	N/A	N/A	N/A
LTE Band 41	Held to head for voice ³	≤72	TBD	N/A	TBD	TBD
		>72	TBD	N/A	TBD	TBD
	Wrist-worn ⁴	All	N/A	TBD	N/A	N/A
	Other ⁵	All	TBD	N/A	N/A	N/A

TABLE 5-21 LTE MINIMUM TRP LEVEL (IN dBm) REQUIREMENTS FOR THE PRIMARY MECHANICAL MODE¹

Band	Use Cases Supported	Device Width (mm) ²	Free Space	WL and WR	BHHL and BHHR	HL and HR
LTE Band 48	Held to head for voice ³	≤72	TBD	N/A	TBD	TBD
		>72	TBD	N/A	TBD	TBD
	Wrist-worn ⁴	All	N/A	TBD	N/A	N/A
	Other ⁵	All	TBD	N/A	N/A	N/A

Note 1: Primary Mechanical Mode refers to device configured in preferred mode per manufacturer instructions (typically means antenna extended, fold or portrait slide open, but depends on form factor).

Note 2: Differences between requirements for devices wider and narrower than 72 mm reflect observed differences in OTA performance with different hand phantoms of up to 6 dB.

Note 3: “Held to head for voice” applies if the device supports voice operation in the talking position against the head in any cellular radio mode.

Note 4: “Wrist-worn” would be applicable to devices that are worn on the wrist, e.g., smartwatches.

Note 5: “Other” would be applicable to data-centric devices that are not held up against the head nor Wrist-worn, e.g., embedded laptop solutions.

5.9 CDMA 1xEV-DO DATA

5.9.1 Test Procedure

The measurement site and EUT shall be configured as specified in [Appendix A](#). The power radiated by the EUT shall be measured using a calibrated and accurate RF measuring instrument (e.g., a spectrum analyzer, or measurement receiver, or power meter).

Note: See [Appendix D](#) for power measurement considerations.

If the EUT supports 1xEV-DO Rev. A, then 1xEV-DO Rev. A shall be used for this test. The CDMA 1xEV-DO test parameters shall be set according to TIA-866-A paragraph 4.3.4 (subtype 2 physical layer) for the Maximum RF Output Power test and to the applicable defaults specified in TIA-866-A section 8, with the exceptions specified in [Table 5-22](#) through [Table 5-24](#).

If the EUT does not support 1xEV-DO Rev. A, then 1xEV-DO Rev. 0 shall be used for this test and the CDMA 1xEV-DO test parameters shall be set according to TIA-866-1 paragraph 3.1.2.3.4 for the Maximum RF Output Power test, and to the applicable defaults specified in TIA-866-1 section 11 with the exceptions specified in [Table 5-22](#) through [Table 5-24](#).

Page the EUT and direct it to a traffic channel. Adjust the Forward Link Power as needed to establish/maintain the traffic channel with a PER such that the transmitter is not gated off during power measurements.

TABLE 5-22 CDMA 1xEV-DO BASE STATION PARAMETERS - CELLULAR BAND

Parameter	Setting
Band Class	0
Channel (Reg.)	As needed ¹
Power Control	Always Up
Path Loss	See Table 4-2
Note 1: Registration channel is service provider-specific.	

TABLE 5-23 CDMA 1xEV-DO BASE STATION PARAMETERS - PCS BAND

Parameter	Setting
Band Class	1
Channel (Reg.)	As needed ¹
Power Control	Always Up
Path Loss	See Table 4-2
Note 1: Registration channel is service provider-specific.	

TABLE 5-24 CDMA 1xEV-DO BASE STATION PARAMETERS - AWS-1 BAND

Parameter	Setting
Band Class	15
Channel (Reg.)	As needed ¹
Power Control	Always Up
Path Loss	See Table 4-2
Note 1: Registration channel is service provider-specific.	

Tests shall be carried out for three different frequency pairs across the bands supported by the EUT (i.e., cellular, PCS and/or AWS-1), as defined in [Table 5-4](#).

Head and hand phantom, hand phantom only and/or free-space testing shall be conducted based on device type, as specified in [Appendix O](#). Refer to [Appendix C](#) for head/hand testing requirements. Perform each test on all specified frequencies with the EUT antenna extended and retracted, as applicable.

Note: That head-adjacent testing is only required for CDMA 1xEV-DO data if the EUT supports usage against the head in this mode (e.g., VoIP).

5.9.2 Criteria

Results shall be reported as specified in [Appendix B](#) using the figures of merit given in [Appendix B.3](#). [Appendix B.1](#) contains the pass/fail OTA tables for CDMA 1xEV-DO. Reports shall include results for free-space and head/hand configurations (if applicable) across all channels measured with the EUT antenna extended and retracted (if applicable).

TABLE 5-25 CDMA 1xEV-DO DATA MINIMUM TRP LEVEL (IN DBM) REQUIREMENTS FOR THE PRIMARY MECHANICAL MODE¹

Band	Device Held Up to Head for Voice (Yes/No)	Antenna Type	Device Power Class	Device Width (mm) ²	FS	BHHL and BHR	HL and HR
CDMA 1xEV-DO DATA 800	Yes ³	Embedded	I	≤72	25	TBD	TBD
			I	>72	25	TBD	TBD
			II	≤72	22	TBD	TBD
			II	>72	22	TBD	TBD
			III	≤72	18	TBD	TBD
			III	>72	18	TBD	TBD
		Stub or Retractable	I	≤72	27	TBD	TBD
			I	>72	27	TBD	TBD
			II	≤72	24	TBD	TBD
			II	>72	24	TBD	TBD
	III		≤72	20	TBD	TBD	
	No ⁴	All	I	All	27	N/A	N/A
			II	All	24	N/A	N/A
			III	All	20	N/A	N/A

TABLE 5-25 CDMA 1xEV-DO DATA MINIMUM TRP LEVEL (IN DBM) REQUIREMENTS FOR THE PRIMARY MECHANICAL MODE¹

Band	Device Held Up to Head for Voice (Yes/No)	Antenna Type	Device Power Class	Device Width (mm) ²	FS	BHHL and BHHR	HL and HR
CDMA 1xEV-DO DATA 1900	Yes ³	Embedded	I	≤72	23	TBD	TBD
			I	>72	23	TBD	TBD
			II	≤72	18	TBD	TBD
			II	>72	18	TBD	TBD
			III	≤72	13	TBD	TBD
			III	>72	13	TBD	TBD
			IV	≤72	8	TBD	TBD
			IV	>72	8	TBD	TBD
			V	≤72	3	TBD	TBD
		V	>72	3	TBD	TBD	
		Stub or Retractable	I	≤72	25	TBD	TBD
			I	>72	25	TBD	TBD
			II	≤72	20	TBD	TBD
			II	>72	20	TBD	TBD
			III	≤72	15	TBD	TBD
			III	>72	15	TBD	TBD
			IV	≤72	10	TBD	TBD
			IV	>72	10	TBD	TBD
	V		≤72	5	TBD	TBD	
	V	>72	5	TBD	TBD		
	No ⁴	All	I	All	25	N/A	N/A
			II	All	20	N/A	N/A
			III	All	15	N/A	N/A
			IV	All	10	N/A	N/A
			V	All	5	N/A	N/A

TABLE 5-25 CDMA 1xEV-DO DATA MINIMUM TRP LEVEL (IN DBM) REQUIREMENTS FOR THE PRIMARY MECHANICAL MODE¹

Band	Device Held Up to Head for Voice (Yes/No)	Antenna Type	Device Power Class	Device Width (mm) ²	FS	BHHL and BHR	HL and HR
CDMA 1xEV-DO DATA 2100/1700	Yes ³	Embedded	I	≤72	22	TBD	TBD
			I	>72	22	TBD	TBD
			II	≤72	17	TBD	TBD
			II	>72	17	TBD	TBD
			III	≤72	12	TBD	TBD
			III	>72	12	TBD	TBD
			IV	≤72	7	TBD	TBD
			IV	>72	7	TBD	TBD
			V	≤72	2	TBD	TBD
		V	>72	2	TBD	TBD	
		Stub or Retractable	I	≤72	22	TBD	TBD
			I	>72	22	TBD	TBD
			II	≤72	17	TBD	TBD
			II	>72	17	TBD	TBD
			III	≤72	12	TBD	TBD
			III	>72	12	TBD	TBD
			IV	≤72	7	TBD	TBD
			IV	>72	7	TBD	TBD
	V		≤72	2	TBD	TBD	
	V	>72	2	TBD	TBD		
	No ⁴	All	I	All	22	N/A	N/A
			II	All	17	N/A	N/A
			III	All	12	N/A	N/A
			IV	All	7	N/A	N/A
			V	All	2	N/A	N/A

Note 1: Primary Mechanical Mode refers to device configured in preferred mode per manufacturer instructions (typically means antenna extended, fold or portrait slide open, but depends on form factor).
 Note 2: Differences between requirements for devices wider and narrower than 72 mm reflect observed differences in OTA performance with different hand phantoms of up to 6 dB.
 Note 3: "Yes" applies if the device supports voice operation in the talking position against the head in any cellular radio mode.
 Note 4: "No" would be applicable to data-centric devices that are not held up against the head, e.g., embedded laptop solutions.

Note: Device Power shall comply with the power levels specified in the relevant industry standard(s).

5.10 CDMA 1xRTT DATA

5.10.1 Test Procedure

The measurement site and EUT shall be configured as specified in [Appendix A](#). The power radiated by the EUT shall be measured using a calibrated and accurate RF measuring instrument (e.g., a spectrum analyzer, or measurement receiver, or power meter).

Note: See [Appendix D](#) for power measurement considerations.

The CDMA test parameters shall be set according to TIA-98-E paragraph 4.4.5 for the Reverse Fundamental Channel Maximum RF Output Power test and to the defaults specified in TIA-98-E paragraph 6.5.2 with the exceptions specified in [Table 5-26](#) through [Table 5-28](#). The Radio Configuration may not be directly settable on certain test boxes. If that is the case, the Radio Configuration will be implicitly set by the Service Option setting. Page the EUT and direct it to a traffic channel. Adjust the Forward Link Power as needed to establish/maintain the traffic channel with an FER such that the transmitter is not gated off during power measurements.

TABLE 5-26 CDMA 1xRTT DATA BASE STATION PARAMETERS - CELLULAR BAND

Parameter	Setting
Type	CDMA
Band Class	0
Channel (Reg.)	As needed ¹
SID	As needed ¹
NID	As needed ¹
Radio Configuration	3
Service Option	32
Rate	Full
Power Control	Always Up
Path Loss	See Table 4-2
Note 1: Registration channel, SID/NID are service provider-specific.	

TABLE 5-27 CDMA 1xRTT DATA BASE STATION PARAMETERS - PCS BAND

Parameter	Setting
Type	CDMA
Band Class	1
Channel (Reg.)	As needed ¹
SID	As needed ¹
NID	As needed ¹

TABLE 5-27 CDMA 1xRTT DATA BASE STATION PARAMETERS - PCS BAND

Parameter	Setting
Radio Configuration	3
Service Option	32
Rate	Full
Power Control	Always Up
Path Loss	See Table 4-2
Note 1: Registration channel, SID/NID are service provider-specific.	

TABLE 5-28 CDMA 1xRTT DATA BASE STATION PARAMETERS - AWS-1 BAND

Parameter	Setting
Type	CDMA
Band Class	15
Channel (Reg.)	As needed ¹
SID	As needed ¹
NID	As needed ¹
Radio Configuration	3
Service Option	32
Rate	Full
Power Control	Always Up
Path Loss	See Table 4-2
Note 1: Registration channel, SID/NID are service provider-specific.	

Tests shall be carried out for three different frequency pairs across the bands supported by the EUT (i.e., cellular, PCS and/or AWS-1), as defined in [Table 5-4](#).

Head and hand phantom, hand phantom only and/or free-space testing shall be conducted based on device type, as specified in [Appendix O](#). Refer to [Appendix C](#) for head/hand testing requirements. Perform each test on all specified frequencies with the EUT antenna extended and retracted, as applicable.

Note: *Head-adjacent testing is only required for CDMA 1xRTT data if the EUT supports usage against the head in this mode (e.g., VoIP).*

5.10.2 Criteria

Results shall be reported as specified in [Appendix B](#) using the figures of merit given in [Appendix B.3](#). [Appendix B.1](#) contains the pass/fail OTA tables for CDMA 1xRTT DATA. Reports shall include results for

free-space and head/hand configurations (if applicable) across all channels measured with the EUT antenna extended and retracted (if applicable).

TABLE 5-29 CDMA 1xRTT DATA MINIMUM TRP LEVEL (IN DBM) REQUIREMENTS FOR THE PRIMARY MECHANICAL MODE¹

Band	Device Held Up to Head for Voice (Yes/No)	Antenna Type	Device Power Class	Device Width (mm) ²	FS	BHHL and BHR	HL and HR
CDMA 1xRTT DATA 800	Yes ³	Embedded	I	≤72	25	TBD	TBD
			I	>72	25	TBD	TBD
			II	≤72	22	TBD	TBD
			II	>72	22	TBD	TBD
			III	≤72	18	TBD	TBD
			III	>72	18	TBD	TBD
		Stub or Retractable	I	≤72	27	TBD	TBD
			I	>72	27	TBD	TBD
			II	≤72	24	TBD	TBD
			II	>72	24	TBD	TBD
			III	≤72	20	TBD	TBD
			III	>72	20	TBD	TBD
	No ⁴	All	I	All	27	N/A	N/A
			II	All	24	N/A	N/A
			III	All	20	N/A	N/A

TABLE 5-29 CDMA 1XRTT DATA MINIMUM TRP LEVEL (IN dBm) REQUIREMENTS FOR THE PRIMARY MECHANICAL MODE¹

Band	Device Held Up to Head for Voice (Yes/No)	Antenna Type	Device Power Class	Device Width (mm) ²	FS	BHHL and BHRH	HL and HR
CDMA 1XRTT DATA 1900	Yes ³	Embedded	I	≤72	23	TBD	TBD
			I	>72	23	TBD	TBD
			II	≤72	18	TBD	TBD
			II	>72	18	TBD	TBD
			III	≤72	13	TBD	TBD
			III	>72	13	TBD	TBD
			IV	≤72	8	TBD	TBD
			IV	>72	8	TBD	TBD
			V	≤72	3	TBD	TBD
			V	>72	3	TBD	TBD
		Stub or Retractable	I	≤72	25	TBD	TBD
			I	>72	25	TBD	TBD
			II	≤72	20	TBD	TBD
			II	>72	20	TBD	TBD
			III	≤72	15	TBD	TBD
			III	>72	15	TBD	TBD
			IV	≤72	10	TBD	TBD
			IV	>72	10	TBD	TBD
	V		≤72	5	TBD	TBD	
	V		>72	5	TBD	TBD	
No ⁴	All	I	All	25	N/A	N/A	
		II	All	20	N/A	N/A	
		III	All	15	N/A	N/A	
		IV	All	10	N/A	N/A	
		V	All	5	N/A	N/A	

TABLE 5-29 CDMA 1XRTT DATA MINIMUM TRP LEVEL (IN dBm) REQUIREMENTS FOR THE PRIMARY MECHANICAL MODE¹

Band	Device Held Up to Head for Voice (Yes/No)	Antenna Type	Device Power Class	Device Width (mm) ²	FS	BHHL and BHRH	HL and HR
CDMA 1XRTT DATA 2100/1700	Yes ³	Embedded	I	≤72	22	TBD	TBD
			I	>72	22	TBD	TBD
			II	≤72	17	TBD	TBD
			II	>72	17	TBD	TBD
			III	≤72	12	TBD	TBD
			III	>72	12	TBD	TBD
			IV	≤72	7	TBD	TBD
			IV	>72	7	TBD	TBD
			V	≤72	2	TBD	TBD
			V	>72	2	TBD	TBD
		Stub or Retractable	I	≤72	22	TBD	TBD
			I	>72	22	TBD	TBD
			II	≤72	17	TBD	TBD
			II	>72	17	TBD	TBD
			III	≤72	12	TBD	TBD
			III	>72	12	TBD	TBD
			IV	≤72	7	TBD	TBD
			IV	>72	7	TBD	TBD
	V		≤72	2	TBD	TBD	
	V		>72	2	TBD	TBD	
No ⁴	All	I	All	22	N/A	N/A	
		II	All	17	N/A	N/A	
		III	All	12	N/A	N/A	
		IV	All	7	N/A	N/A	
		V	All	2	N/A	N/A	

Note 1: Primary Mechanical Mode refers to device configured in preferred mode per manufacturer instructions (typically means antenna extended, fold or portrait slide open, but depends on form factor).
 Note 2: Differences between requirements for devices wider and narrower than 72 mm reflect observed differences in OTA performance with different hand phantoms of up to 6 dB.
 Note 3: "Yes" applies if the device supports voice operation in the talking position against the head in any cellular radio mode.
 Note 4: "No" would be applicable to data-centric devices that are not held up against the head, e.g., embedded laptop solutions.

Note: Device Power shall comply with the power levels specified in the relevant industry standard(s).

5.11 Alternate Test Procedure for TRP

These alternate test procedures can significantly reduce the test time for TRP.

Use of these alternate test methods may require additional measurement uncertainty calculations, which are discussed in [Section 7.3](#).

5.11.1 Single Point Offset Test (SPOT)

This offset test procedure significantly reduces the test time for TRP for multi-protocol phones, which have more than one protocol in the same frequency band. This offset test procedure can be used to determine the offset in TRP between different protocols on equivalent channels. “Equivalent channels” assumes that the two channels are close enough in frequency that the pattern does not change. This method may be used between stand-alone LTE and LTE CA or one LTE CA combination and another, when the same band, channel and RB allocation combination is evaluated in both LTE combinations if single point offset testing (SPOT) is allowed for the CA combination as specified in the operator CA combination priority list identified in [Appendix O.8](#).

This offset test procedure for TRP cannot be used with an antenna which uses a different physical radiator, or different aperture tuning (e.g. matching on parasitic elements or matching components on the ground or within the radiator) between the reference protocol and the protocol being evaluated. This offset test procedure cannot be used in this case because the antenna pattern will generally be different between the 2 protocols.

This offset test procedure for TRP can be used with an antenna which uses the same physical radiator, the same aperture tuning (e.g. matching on parasitic elements or matching components on the ground or within the radiator) but uses different impedance matching (e.g. matching components on the RF feed) between the reference protocol and the protocol being evaluated,

The manufacturer must declare to the ATL when antennas are implemented in such a way that this offset test procedure for TRP cannot be used, when single point offset tests are considered.

It is recommended that voice digital protocols be given priority when doing full TRP measurements. For purposes of clarity for the following test procedure, test configuration A will be the reference protocol for which a full TRP measurement is performed. Test configuration B will be the other protocol to be tested using the single point radiated test.

Either test sequence is repeated for each channel specified in the appropriate part of [Section 5](#). Either test sequence shall be repeated for each EUT antenna configuration (free space, head and hand phantom, hand phantom only, whip extended, whip retracted). The single/multi point radiated power for both test configurations, the difference, and the calculated TRP for test configuration B shall be recorded.

The TRP test for test configuration A shall be completed first according to the appropriate part of [Section 5](#). After identifying the position and polarization for which the EUT has its maximum radiated power for one channel, the EUT should be placed in the same configuration. A radiated power measurement shall be first done in test configuration A according to the relevant procedures in [Section 5](#). If possible without touching the phone, initiate a hand-off or change to test configuration B at the equivalent channel. Otherwise, initiate a call in test configuration B and go to the equivalent channel. If the phone must be handled in order to initiate a call in test configuration B, then an additional repositioning uncertainty must be included to account for positioning repeatability. Following that, a radiated power measurement shall be done in test configuration B according to the relevant procedures in [Section 5](#). The two measurements shall be conducted as close in time as possible. The difference between these radiated

tests shall then be used as an offset to the TRP for test configuration A in order to calculate the TRP for test configuration B.

Note: *This test procedure is well suited for pairs of test configurations where hand-offs to and from each test configuration are both not possible.*

5.11.2 Multi-point Offset Test

This offset method has similar benefits as the Single-Point Offset Test in [Section 5.11.1](#) and has the same restrictions as discussed in [Section 5.11.1](#).

Multiple positions and polarizations shall be predetermined for comparing test configurations A and B. The test positions and polarizations shall be selected such that they are spread relatively evenly in time throughout the TRP test and are spread relatively evenly in space over the sphere. While the TRP test for test configuration A is being performed, measurements for test configuration B will be performed at those predetermined positions and polarizations. This is accomplished at those predetermined positions and polarizations by:

1. Measuring the radiated power for test configuration A
2. Handing-off or changing to test configuration B
3. Measuring the radiated power for test configuration B
4. Handing-off or changing to test configuration A
5. And finally continuing the TRP test until another predetermined position and polarization is to be tested, at which time, steps 1 to 5 are repeated.

The handset shall not be moved between handoffs between configuration A and B and back. Exclude measurement points, which are less than 20 dB above the noise floor, for use in this multi-point test. The difference between the averages of the radiated tests at the predetermined positions and polarizations shall then be used as an offset to the TRP for test configuration A in order to calculate the TRP for test configuration B.

Note: *This test procedure is well suited for pairs of test configurations where hand-offs to and from each test configuration are both possible.*

Note: *More than four test positions/polarizations are recommended to keep the measurement uncertainty low.*

Note: *This test procedure using multiple test positions/polarizations will have lower uncertainty than the test procedure using a single test position/polarization.*

5.11.3 Spiral Scan Procedure for TRP

This alternate test procedure significantly reduces the test time for TRP when used in conjunction with appropriate measurement systems. This method relies on continuous rotation of both the theta and phi positioner during the collection of data points. Power measurements on the measurement antenna for both the theta and phi polarizations may be taken simultaneously or in rapid succession. Alternately, each polarization may be measured for a complete spiral and the computed spherical quantities for each polarization may then be combined to obtain the total metrics. In either case, the measurement location (theta, phi) shall be recorded for each measurement point along with the measurement value.

FIGURE 5-1 SPIRAL SCAN MEASUREMENT POINTS (LEFT) AND STANDARD (EQUALLY SPACED) MEASUREMENT POINTS (RIGHT)

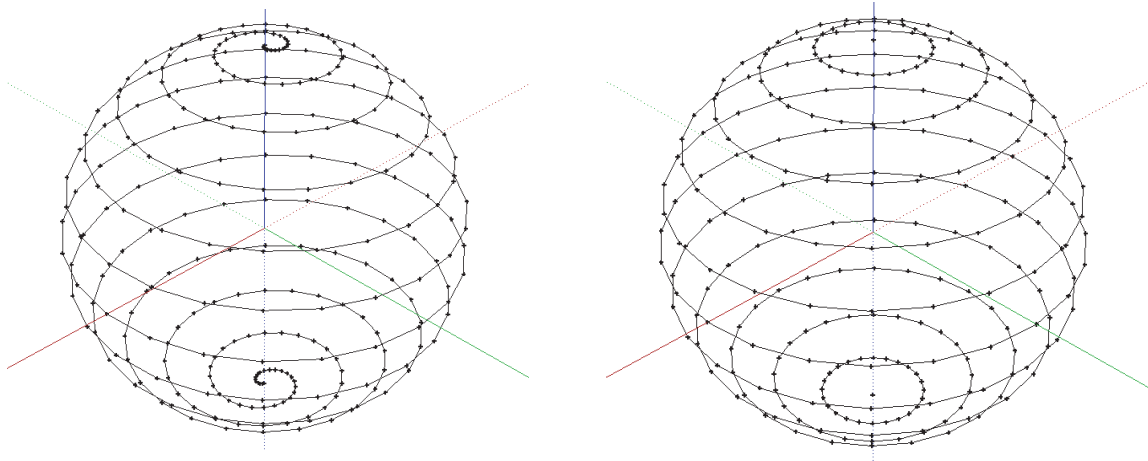

The spiral scan TRP procedure may be used without respect to communication protocol.

Due to the nature of the test systems being used, it is not required that point spacing when using the spiral scan be exactly 15 degrees. However, equal spacing of the test points shall be prioritized and the following criteria shall be achieved:

1. The maximum theta rotation between subsequent turns in the spiral at the same phi angle shall be 15 degrees for each polarization.
2. The maximum spacing between adjacent points in phi for each polarization shall be 15 degrees.
3. Points shall be oversampled relative to the standard 15 degree spacing, such that the minimum number of total measurement locations shall be 350 (x 2 polarizations = 700 total data points).

This alternate test method does not require additional measurement uncertainty calculations.

5.11.4 TRP Measurement of Low Transmit Duty-Cycle Devices

An underlying assumption in the TRP test methodologies described in Sections 5.2, 5.4 through 5.10, and 5.15 of this document is that the EUT is capable of supporting a moderate to high transmit duty-cycle during normal operation. However, some EUTs are designed to transmit at full power for only a fraction of each hour, and as a result, typically have a very small heatsink for the power amplifier and a relatively low-capacity battery. Attempts to measure TRP using the current CTIA Certification methodology will, in many cases, cause the EUT to be damaged due to excessive heat.

The TRP test methodology described below applies only to EUTs which have insufficient power/thermal capacity to maintain the cellular link for at least 50% of the execution time of a single-channel TRP or TIS test. This methodology applies regardless of cellular radio mode, so it may be utilized, as applicable, for any EUT which would otherwise be tested according to Sections 5.2, 5.4 through 5.10, and 5.15 of this document.

1. If the EUT supports multiple cellular radio modes, determine which cellular radio mode includes the highest number of CTIA Certification normative bands. If more than one cellular radio mode supports the same number of bands, the highest-order supported cellular radio mode (e.g. LTE > UMTS) shall be selected to begin this TRP test procedure.
2. Configure the network simulator so that the EUT output power will be approximately 10 dB below full output power. It's not necessary to set the uplink power to exactly 10 dB below full-power, it's only necessary to ensure that the EUT's uplink power setting on the network simulator is known and maintained through the execution of all subsequent tests, except as noted. The recommended device warm up time described in Clause 5 of this document should be applied to the reduced output power.
3. With the network simulator set to command the EUT to operate at a reduced output power as noted in Step 2, execute the TRP measurement process in one of the EUT's supported bands following the CTIA Certification procedure for the airlink under test.
4. Once radiated power data from all measurement points have been collected for all three reference channels in the selected band, determine the peak in the EUT's antenna pattern per reference channel and orient the measurement antenna(s) to the peak associated with the low-frequency measurement channel.
5. With the measurement antennas at the low-frequency antenna pattern peak as described in Step 4, obtain a single radiated power measurement at reduced power. Document the EUT's radiated power at this measurement location for reduced power.
6. Command the EUT to transmit at full-power only long enough to obtain a single radiated power measurement on the low-frequency reference channel. Document the radiated power at this measurement location for full power.
7. Repeat Steps 5 and 6 for the remaining reference channels in the selected band, using the measurement antenna locations corresponding to the peak in the EUT's antenna pattern at each reference frequency.
8. Repeat Steps 3 through 7 for all bands and cellular radio modes supported by the EUT. If any subsequent cellular radio modes include bands not tested in Steps 2 through 7, follow a similar TRP measurement methodology for the previously-untested band(s) or cellular radio mode(s).

5.12 LTE Two Downlink Carrier Aggregation (Single Uplink Carrier)

The number and type of measurements required to support TRP performance evaluation shall be determined based on the CA specific test requirements for carrier aggregation testing as described in [Appendix O.8.1](#).

5.12.1 Test Procedure

This test procedure applies only for two downlink carrier aggregation with a single uplink carrier on the PCC. This test procedure applies for both inter-band and intra-band cases.

The measurement site and EUT shall be configured as specified in [Appendix A](#). The power radiated by the EUT shall be measured using a calibrated and accurate RF measuring instrument (e.g., a spectrum analyzer, or measurement receiver, or power meter).

See [Appendix D](#) for power measurement considerations.

The LTE system simulator and EUT shall be configured per 3GPP TS 36.521-1, Section 6.2.2A (UE Maximum Output Power) using the default settings specified in 3GPP TS 36.521-1 and 3GPP TS 36.508 as applicable. The test procedure in section 6.2.2A of 3GPP TS 36.521-1 shall be used to measure the UE output power of the PCC. Adjust the downlink signal power of all CCs as needed to establish/maintain the LTE connection with a BLER such that the device does not miss PDCCH grants and the transmitter is not gated off during power measurements.

In order to reduce the need for communication tester upgrades or additions, testing LTE CA 2 DL combinations in stand-alone LTE is allowed under certain conditions as long as the antenna tuning is set according to the CA 2 DL combination that is being evaluated. The PCC TRP for a 2 DL CA combination may be tested in stand-alone LTE mode with the antenna tuned for operation in the 2 DL CA combination.

For example, when evaluating an interband 2 DL CA case, CA_xA-yA, where x and y are the LTE bands and the PCC is in LTE x, then the following tests are permitted:

1. TRP for x in CA_xA-yA may be tested in stand-alone LTE x with the antenna tuned for operation in CA_xA-yA.

Device manufacturers using dynamically tuned antennas should in general have a method of altering the antenna tuning in order to do the necessary antenna tuning optimization during the R&D phase. In general, the settings for the antenna tuner are stored in a tuning file. Consequently, the antenna tuning can be modified by writing a different tuning file into the device. All the stand-alone LTE bands could be tested using the normal tuning file. A second tuning file for testing the 2 DL CA modes could be created where the antenna tuner settings for the stand-alone LTE bands are changed to the antenna tuner settings for the associated 2 DL CA mode.

Tests shall be carried out for different carrier aggregation frequency combinations and RB allocations across the bands supported by the EUT, as defined in Table 5-30.

TABLE 5-30 LTE CARRIER AGGREGATION MODE (2 DOWNLINK CARRIERS, 1 UPLINK CARRIER) TRP MEASUREMENTS
TABLE FOR THE PRIMARY MECHANICAL MODE¹

Carrier Aggregation Combination	Primary Component Carrier (PCC) Band	Secondary Component Carrier (SCC) Band	PCC BW (MHz)	SCC BW (MHz)	PCC UL Channel	SCC DL Channel	PCC UL RB Allocation	PCC DL RB Allocation	SCC DL RB Allocation
CA_2A-2A ²	2	2	10	10	18650	900	12 RB with RBstart=0	N/A ³	N/A ³
			10	10	18900	1150	12 RB with RBstart=19	N/A ³	N/A ³
			10	10	19150	650	12 RB with RBstart=38	N/A ³	N/A ³
CA_2A-4A ⁴	2	4	10	10	18650	2350	12 RB with RBstart=0	N/A ³	N/A ³
			10	10	18900	2350	12 RB with RBstart=19	N/A ³	N/A ³
			10	10	19150	2350	12 RB with RBstart=38	N/A ³	N/A ³
CA_2A-5A	2	5	10	10	18650	2450	12 RB with RBstart=0	N/A ³	N/A ³
			10	10	18900	2450	12 RB with RBstart=19	N/A ³	N/A ³
			10	10	19150	2450	12 RB with RBstart=38	N/A ³	N/A ³
CA_2A-12A ⁵	2	12	10	5	18650	5035	12 RB with RBstart=0	N/A ³	N/A ³
			10	5	18900	5035	12 RB with RBstart=19	N/A ³	N/A ³
			10	5	19150	5035	12 RB with RBstart=38	N/A ³	N/A ³
CA_2A-13A	2	13	10	10	18650	5230	12 RB with RBstart=0	N/A ³	N/A ³
			10	10	18900	5230	12 RB with RBstart=19	N/A ³	N/A ³
			10	10	19150	5230	12 RB with RBstart=38	N/A ³	N/A ³

TABLE 5-30 LTE CARRIER AGGREGATION MODE (2 DOWNLINK CARRIERS, 1 UPLINK CARRIER) TRP MEASUREMENTS
TABLE FOR THE PRIMARY MECHANICAL MODE¹

Carrier Aggregation Combination	Primary Component Carrier (PCC) Band	Secondary Component Carrier (SCC) Band	PCC BW (MHz)	SCC BW (MHz)	PCC UL Channel	SCC DL Channel	PCC UL RB Allocation	PCC DL RB Allocation	SCC DL RB Allocation
CA_2A-17A ⁵	2	17	10	10	18650	5800	12 RB with RBstart=0	N/A ³	N/A ³
			10	10	18900	5800	12 RB with RBstart=19	N/A ³	N/A ³
			10	10	19150	5800	12 RB with RBstart=38	N/A ³	N/A ³
CA_2A-29A	2	29	10	10	18650	9720	12 RB with RBstart=0	N/A ³	N/A ³
			10	10	18900	9720	12 RB with RBstart=19	N/A ³	N/A ³
			10	10	19150	9720	12 RB with RBstart=38	N/A ³	N/A ³
CA_2A-30A	2	30	10	10	18650	9820	12 RB with RBstart=0	N/A ³	N/A ³
			10	10	18900	9820	12 RB with RBstart=19	N/A ³	N/A ³
			10	10	19150	9820	12 RB with RBstart=38	N/A ³	N/A ³
CA_2A-48A	2	48	10	10	18650	56690	12 RB with RBstart=0	N/A ³	N/A ³
			10	10	18900	56690	12 RB with RBstart=19	N/A ³	N/A ³
			10	10	19150	56690	12 RB with RBstart=38	N/A ³	N/A ³
CA_2A-66A ⁴	2	66	10	10	18650	67286	12 RB with RBstart=0	N/A ³	N/A ³
			10	10	18900	67286	12 RB with RBstart=19	N/A ³	N/A ³
			10	10	19150	67286	12 RB with RBstart=38	N/A ³	N/A ³
CA_4A-2A ⁴	4	2	10	10	20000	650	12 RB with RBstart=0	N/A ³	N/A ³
			10	10	20175	650	12 RB with RBstart=19	N/A ³	N/A ³
			10	10	20350	650	12 RB with RBstart=38	N/A ³	N/A ³
CA_4A-4A ⁴	4	4	10	10	20000	2175	12 RB with RBstart=0	N/A ³	N/A ³
			10	10	20175	2350	12 RB with RBstart=19	N/A ³	N/A ³
			10	10	20350	2000	12 RB with RBstart=38	N/A ³	N/A ³
CA_4A-5A ⁴	4	5	10	10	20000	2450	12 RB with RBstart=0	N/A ³	N/A ³
			10	10	20175	2450	12 RB with RBstart=19	N/A ³	N/A ³
			10	10	20350	2450	12 RB with RBstart=38	N/A ³	N/A ³
CA_4A-12A ^{4,5}	4	12	10	5	20000	5035	12 RB with RBstart=0	N/A ³	N/A ³
			10	5	20175	5035	12 RB with RBstart=19	N/A ³	N/A ³
			10	5	20350	5035	12 RB with RBstart=38	N/A ³	N/A ³
CA_4A-13A ⁴	4	13	10	10	20000	5230	12 RB with RBstart=0	N/A ³	N/A ³
			10	10	20175	5230	12 RB with RBstart=19	N/A ³	N/A ³
			10	10	20350	5230	12 RB with RBstart=38	N/A ³	N/A ³
CA_4A-17A ^{4,5}	4	17	10	10	20000	5800	12 RB with RBstart=0	N/A ³	N/A ³
			10	10	20175	5800	12 RB with RBstart=19	N/A ³	N/A ³
			10	10	20350	5800	12 RB with RBstart=38	N/A ³	N/A ³
CA_4A-29A ⁴	4	29	10	10	20000	9720	12 RB with RBstart=0	N/A ³	N/A ³
			10	10	20175	9720	12 RB with RBstart=19	N/A ³	N/A ³
			10	10	20350	9720	12 RB with RBstart=38	N/A ³	N/A ³

TABLE 5-30 LTE CARRIER AGGREGATION MODE (2 DOWNLINK CARRIERS, 1 UPLINK CARRIER) TRP MEASUREMENTS
TABLE FOR THE PRIMARY MECHANICAL MODE¹

Carrier Aggregation Combination	Primary Component Carrier (PCC) Band	Secondary Component Carrier (SCC) Band	PCC BW (MHz)	SCC BW (MHz)	PCC UL Channel	SCC DL Channel	PCC UL RB Allocation	PCC DL RB Allocation	SCC DL RB Allocation
CA_4A-30A ⁴	4	30	10	10	20000	9820	12 RB with RBstart=0	N/A ³	N/A ³
			10	10	20175	9820	12 RB with RBstart=19	N/A ³	N/A ³
			10	10	20350	9820	12 RB with RBstart=38	N/A ³	N/A ³
CA_5A-2A	5	2	10	10	20450	1150	12 RB with RBstart=0	N/A ³	N/A ³
			10	10	20525	1150	12 RB with RBstart=19	N/A ³	N/A ³
			10	10	20600	1150	12 RB with RBstart=38	N/A ³	N/A ³
CA_5A-4A ⁴	5	4	10	10	20450	2350	12 RB with RBstart=0	N/A ³	N/A ³
			10	10	20525	2350	12 RB with RBstart=19	N/A ³	N/A ³
			10	10	20600	2350	12 RB with RBstart=38	N/A ³	N/A ³
CA_5B ²	5	5	10	10	20450	2549	12 RB with RBstart=0	N/A ³	N/A ³
			10	10	20600	2501	12 RB with RBstart=38	N/A ³	N/A ³
CA_5A-5A ²	5	5	5	5	20425	2525	8 RB with RBstart=0	N/A ³	N/A ³
			5	5	20525	2625	8 RB with RBstart=8	N/A ³	N/A ³
			5	5	20625	2425	8 RB with RBstart=17	N/A ³	N/A ³
CA_5A-30A	5	30	10	10	20450	9820	12 RB with RBstart=0	N/A ³	N/A ³
			10	10	20525	9820	12 RB with RBstart=19	N/A ³	N/A ³
			10	10	20600	9820	12 RB with RBstart=38	N/A ³	N/A ³
CA_5A-48A	5	48	10	10	20450	56690	12 RB with RBstart=0	N/A ³	N/A ³
			10	10	20525	56690	12 RB with RBstart=19	N/A ³	N/A ³
			10	10	20600	56690	12 RB with RBstart=38	N/A ³	N/A ³
CA_5A-66A ⁴	5	66	10	10	20450	67286	12 RB with RBstart=0	N/A ³	N/A ³
			10	10	20525	67286	12 RB with RBstart=19	N/A ³	N/A ³
			10	10	20600	67286	12 RB with RBstart=38	N/A ³	N/A ³
CA_12A-2A ⁵	12	2	5	10	23035	1150	8 RB with RBstart=0	N/A ³	N/A ³
			5	10	23095	1150	8 RB with RBstart=8	N/A ³	N/A ³
			5	10	23155	1150	8 RB with RBstart=17	N/A ³	N/A ³
CA_12A-4A ^{2,4}	12	4	5	10	23035	2350	8 RB with RBstart=0	N/A ³	N/A ³
			5	10	23095	2350	8 RB with RBstart=8	N/A ³	N/A ³
			5	10	23155	2350	8 RB with RBstart=17	N/A ³	N/A ³
CA_12A-30A	12	30	5	10	23035	9820	8 RB with RBstart=0	N/A ³	N/A ³
			5	10	23095	9820	8 RB with RBstart=8	N/A ³	N/A ³
			5	10	23155	9820	8 RB with RBstart=17	N/A ³	N/A ³
CA_12A-66A ^{2,4,5}	12	66	5	10	23035	67286	8 RB with RBstart=0	N/A ³	N/A ³
			5	10	23095	67286	8 RB with RBstart=8	N/A ³	N/A ³
			5	10	23155	67286	8 RB with RBstart=17	N/A ³	N/A ³

TABLE 5-30 LTE CARRIER AGGREGATION MODE (2 DOWNLINK CARRIERS, 1 UPLINK CARRIER) TRP MEASUREMENTS
TABLE FOR THE PRIMARY MECHANICAL MODE¹

Carrier Aggregation Combination	Primary Component Carrier (PCC) Band	Secondary Component Carrier (SCC) Band	PCC BW (MHz)	SCC BW (MHz)	PCC UL Channel	SCC DL Channel	PCC UL RB Allocation	PCC DL RB Allocation	SCC DL RB Allocation
CA_13A-2A	13	2	10	10	23230	1150	12 RB with RBstart=0	N/A ³	N/A ³
			10	10	23230	1150	12 RB with RBstart=19	N/A ³	N/A ³
			10	10	23230	1150	12 RB with RBstart=38	N/A ³	N/A ³
CA_13A-4A ⁴	13	4	10	10	23230	2350	12 RB with RBstart=0	N/A ³	N/A ³
			10	10	23230	2350	12 RB with RBstart=19	N/A ³	N/A ³
			10	10	23230	2350	12 RB with RBstart=38	N/A ³	N/A ³
CA_13A-48A	13	48	10	10	23230	56690	12 RB with RBstart=0	N/A ³	N/A ³
			10	10	23230	56690	12 RB with RBstart=19	N/A ³	N/A ³
			10	10	23230	56690	12 RB with RBstart=38	N/A ³	N/A ³
CA_13A-66A ⁴	13	66	10	10	23230	67286	12 RB with RBstart=0	N/A ³	N/A ³
			10	10	23230	67286	12 RB with RBstart=19	N/A ³	N/A ³
			10	10	23230	67286	12 RB with RBstart=38	N/A ³	N/A ³
CA_17A-2A ⁵	17	2	10	10	23780	1150	12 RB with RBstart=0	N/A ³	N/A ³
			10	10	23790	1150	12 RB with RBstart=19	N/A ³	N/A ³
			10	10	23800	1150	12 RB with RBstart=38	N/A ³	N/A ³
CA_17A-4A ^{2,4}	17	4	10	10	23780	2350	12 RB with RBstart=0	N/A ³	N/A ³
			10	10	23790	2350	12 RB with RBstart=19	N/A ³	N/A ³
			10	10	23800	2350	12 RB with RBstart=38	N/A ³	N/A ³
CA_17A-66A ^{2,4,5}	17	66	10	10	23780	67286	12 RB with RBstart=0	N/A ³	N/A ³
			10	10	23790	67286	12 RB with RBstart=19	N/A ³	N/A ³
			10	10	23800	67286	12 RB with RBstart=38	N/A ³	N/A ³
CA_25A-25A	25	25	5	5	26065	8665	8 RB with RBstart=0	N/A ³	N/A ³
			5	5	26365	8665	8 RB with RBstart=8	N/A ³	N/A ³
			5	5	26665	8665	8 RB with RBstart=17	N/A ³	N/A ³
CA_25A-26A	25	26	5	5	26065	9015	8 RB with RBstart=0	N/A ³	N/A ³
			5	5	26365	9015	8 RB with RBstart=8	N/A ³	N/A ³
			5	5	26665	9015	8 RB with RBstart=17	N/A ³	N/A ³
CA_25A-41A	25	41	5	20	26065	41490	8 RB with RBstart=0	N/A ³	N/A ³
			5	20	26365	41490	8 RB with RBstart=8	N/A ³	N/A ³
			5	20	26665	41490	8 RB with RBstart=17	N/A ³	N/A ³
CA_26A-25A	26	25	5	5	26715	8065	8 RB with RBstart=0	N/A ³	N/A ³
			5	5	26865	8065	8 RB with RBstart=8	N/A ³	N/A ³
			5	5	27015	8065	8 RB with RBstart=17	N/A ³	N/A ³
CA_26A-41A	26	41	5	20	26715	41490	8 RB with RBstart=0	N/A ³	N/A ³
			5	20	26865	41490	8 RB with RBstart=8	N/A ³	N/A ³
			5	20	27015	41490	8 RB with RBstart=17	N/A ³	N/A ³

TABLE 5-30 LTE CARRIER AGGREGATION MODE (2 DOWNLINK CARRIERS, 1 UPLINK CARRIER) TRP MEASUREMENTS
TABLE FOR THE PRIMARY MECHANICAL MODE¹

Carrier Aggregation Combination	Primary Component Carrier (PCC) Band	Secondary Component Carrier (SCC) Band	PCC BW (MHz)	SCC BW (MHz)	PCC UL Channel	SCC DL Channel	PCC UL RB Allocation	PCC DL RB Allocation	SCC DL RB Allocation
CA_30A-2A	30	2	10	10	27710	650	12 RB with RBstart=0	N/A ³	N/A ³
			10	10	27710	650	12 RB with RBstart=19	N/A ³	N/A ³
			10	10	27710	650	12 RB with RBstart=38	N/A ³	N/A ³
CA_30A-4A ⁴	30	4	10	10	27710	2000	12 RB with RBstart=0	N/A ³	N/A ³
			10	10	27710	2000	12 RB with RBstart=19	N/A ³	N/A ³
			10	10	27710	2000	12 RB with RBstart=38	N/A ³	N/A ³
CA_30A-5A	30	5	10	10	27710	2450	12 RB with RBstart=0	N/A ³	N/A ³
			10	10	27710	2450	12 RB with RBstart=19	N/A ³	N/A ³
			10	10	27710	2450	12 RB with RBstart=38	N/A ³	N/A ³
CA_30A-12A	30	12	10	5	27710	5035	12 RB with RBstart=0	N/A ³	N/A ³
			10	5	27710	5035	12 RB with RBstart=19	N/A ³	N/A ³
			10	5	27710	5035	12 RB with RBstart=38	N/A ³	N/A ³
CA_30A-29A	30	29	10	10	27710	9720	12 RB with RBstart=0	N/A ³	N/A ³
			10	10	27710	9720	12 RB with RBstart=19	N/A ³	N/A ³
			10	10	27710	9720	12 RB with RBstart=38	N/A ³	N/A ³
CA_30A-66A ⁴	30	66	10	10	27710	67286	12 RB with RBstart=0	N/A ³	N/A ³
			10	10	27710	67286	12 RB with RBstart=19	N/A ³	N/A ³
			10	10	27710	67286	12 RB with RBstart=38	N/A ³	N/A ³
CA_41A-25A	41	25	20	5	39750	8065	18 RB with RBstart=0	N/A ³	N/A ³
			20	5	40620	8065	18 RB with RBstart=41	N/A ³	N/A ³
			20	5	41490	8065	18 RB with RBstart=82	N/A ³	N/A ³
CA_41A-26A	41	26	20	5	39750	8715	18 RB with RBstart=0	N/A ³	N/A ³
			20	5	40620	8715	18 RB with RBstart=41	N/A ³	N/A ³
			20	5	41490	8715	18 RB with RBstart=82	N/A ³	N/A ³
CA_41C	41	41	20	20	39750	39948	18 RB with RBstart=0	N/A ³	N/A ³
			20	20	40620	40422	18 RB with RBstart=41	N/A ³	N/A ³
			20	20	41490	41292	18 RB with RBstart=82	N/A ³	N/A ³
CA_41A-41A	41	41	20	20	39750	40620	18 RB with RBstart=0	N/A ³	N/A ³
			20	20	40620	41490	18 RB with RBstart=41	N/A ³	N/A ³
			20	20	41490	39750	18 RB with RBstart=82	N/A ³	N/A ³
CA_48A-2A	48	2	10	10	55290	650	12 RB with RBstart=0	N/A ³	N/A ³
			10	10	55990	650	12 RB with RBstart=19	N/A ³	N/A ³
			10	10	56690	650	12 RB with RBstart=38	N/A ³	N/A ³
CA_48A-5A	48	5	10	10	55290	2450	12 RB with RBstart=0	N/A ³	N/A ³
			10	10	55990	2450	12 RB with RBstart=19	N/A ³	N/A ³
			10	10	56690	2450	12 RB with RBstart=38	N/A ³	N/A ³

TABLE 5-30 LTE CARRIER AGGREGATION MODE (2 DOWNLINK CARRIERS, 1 UPLINK CARRIER) TRP MEASUREMENTS
TABLE FOR THE PRIMARY MECHANICAL MODE¹

Carrier Aggregation Combination	Primary Component Carrier (PCC) Band	Secondary Component Carrier (SCC) Band	PCC BW (MHz)	SCC BW (MHz)	PCC UL Channel	SCC DL Channel	PCC UL RB Allocation	PCC DL RB Allocation	SCC DL RB Allocation
CA_48A-13A	48	13	10	10	55290	5230	12 RB with RBstart=0	N/A ³	N/A ³
			10	10	55990	5230	12 RB with RBstart=19	N/A ³	N/A ³
			10	10	56690	5230	12 RB with RBstart=38	N/A ³	N/A ³
CA_48A-66A	48	66	10	10	55290	66486	12 RB with RBstart=0	N/A ³	N/A ³
			10	10	55990	66486	12 RB with RBstart=19	N/A ³	N/A ³
			10	10	56690	66486	12 RB with RBstart=38	N/A ³	N/A ³
CA_66A-2A ⁴	66	2	10	10	132022	650	12 RB with RBstart=0	N/A ³	N/A ³
			10	10	132322	650	12 RB with RBstart=19	N/A ³	N/A ³
			10	10	132622	650	12 RB with RBstart=38	N/A ³	N/A ³
CA_66A-5A ⁴	66	5	10	10	132022	2450	12 RB with RBstart=0	N/A ³	N/A ³
			10	10	132322	2450	12 RB with RBstart=19	N/A ³	N/A ³
			10	10	132622	2450	12 RB with RBstart=38	N/A ³	N/A ³
CA_66A-12A ^{2,4,5}	66	12	10	5	132022	5035	12 RB with RBstart=0	N/A ³	N/A ³
			10	5	132322	5035	12 RB with RBstart=19	N/A ³	N/A ³
			10	5	132622	5035	12 RB with RBstart=38	N/A ³	N/A ³
CA_66A-13A ⁴	66	13	10	10	132022	5230	12 RB with RBstart=0	N/A ³	N/A ³
			10	10	132322	5230	12 RB with RBstart=19	N/A ³	N/A ³
			10	10	132622	5230	12 RB with RBstart=38	N/A ³	N/A ³
CA_66A-17A ^{2,4,5}	66	17	10	10	132022	5800	12 RB with RBstart=0	N/A ³	N/A ³
			10	10	132322	5800	12 RB with RBstart=19	N/A ³	N/A ³
			10	10	132622	5800	12 RB with RBstart=38	N/A ³	N/A ³
CA_66A-29A ⁴	66	29	10	10	132022	9720	12 RB with RBstart=0	N/A ³	N/A ³
			10	10	132322	9720	12 RB with RBstart=19	N/A ³	N/A ³
			10	10	132622	9720	12 RB with RBstart=38	N/A ³	N/A ³
CA_66A-30A ⁴	66	30	10	10	132022	9820	12 RB with RBstart=0	N/A ³	N/A ³
			10	10	132322	9820	12 RB with RBstart=19	N/A ³	N/A ³
			10	10	132622	9820	12 RB with RBstart=38	N/A ³	N/A ³
CA_66C ⁶	66	66	10	20	132022	66630	12 RB with RBstart=0	N/A ³	N/A ³
			10	20	132322	66930	12 RB with RBstart=19	N/A ³	N/A ³
			10	20	132622	67230	12 RB with RBstart=38	N/A ³	N/A ³
CA_66A-48A ²	66	48	10	10	132022	56690	12 RB with RBstart=0	N/A ³	N/A ³
			10	10	132322	56690	12 RB with RBstart=19	N/A ³	N/A ³
			10	10	132622	56690	12 RB with RBstart=38	N/A ³	N/A ³
CA_66A-66A ⁴	66	66	10	10	132022	67286	12 RB with RBstart=0	N/A ³	N/A ³
			10	10	132322	67286	12 RB with RBstart=19	N/A ³	N/A ³
			10	10	132622	66486	12 RB with RBstart=38	N/A ³	N/A ³

TABLE 5-30 LTE CARRIER AGGREGATION MODE (2 DOWNLINK CARRIERS, 1 UPLINK CARRIER) TRP MEASUREMENTS
TABLE FOR THE PRIMARY MECHANICAL MODE¹

Carrier Aggregation Combination	Primary Component Carrier (PCC) Band	Secondary Component Carrier (SCC) Band	PCC BW (MHz)	SCC BW (MHz)	PCC UL Channel	SCC DL Channel	PCC UL RB Allocation	PCC DL RB Allocation	SCC DL RB Allocation
CA_70C	70	70	15	10	133047	68531	16 RB with RBstart=0	N/A ³	N/A ³
			15	10	133047	68531	16 RB with RBstart=29	N/A ³	N/A ³
			15	10	133047	68531	16 RB with RBstart=59	N/A ³	N/A ³
<p>Note 1: Primary Mechanical Mode refers to device configured in preferred mode per manufacturer instructions (typically means antenna extended, fold or portrait slide open, but depends on form factor).</p> <p>Note 2: This combination creates harmonic, intermodulation, or self-desense interference to the SCC. The power level of the SCC shall be adjusted as needed to maintain the LTE carrier aggregation connection and error free operation on the SCC.</p> <p>Note 3: As per 3GPP TS 36.521-1, Section 6.2.2A (UE Maximum Output Power for CA).</p> <p>Note 4: If the device supports both CA_4A-xA and CA_66A-xA (where x is the band number of the SCC), then testing is only required in CA_66A-xA. Similarly, if the device supports both CA_xA-4A and CA_xA-66A (where x is the band number of the PCC), then testing is only required in CA_xA-66A.</p> <p>Note 5: If the device supports both CA_12A-xA and CA_17A-xA (where x is the band number of the SCC), then testing is only required in CA_12A-xA. Similarly, if the device supports both CA_xA-12A and CA_xA-17A (where x is the band number of the PCC), then testing is only required in CA_xA-12A.</p> <p>Note 6: Since all Band 66-capable devices are required to support both CA_66B and CA_66C per 3GPP TS 36.101, testing of CA_66B is not required.</p>									

Hand phantom only and/or free-space testing shall be conducted based on device type, as specified in [Appendix O](#). Refer to [Appendix C](#) for hand testing requirements. Perform each test on all specified frequencies and RB allocations with the EUT antenna extended and retracted, as applicable.

Note: Head-adjacent testing is not required for LTE CA.

5.12.2 Criteria

Results shall be reported as specified in [Appendix B](#) using the figures of merit given in [Appendix B.3](#). [Appendix B.1](#) contains the pass/fail OTA tables for 2 downlink LTE carrier aggregation. Reports shall include results for free-space and hand only configurations (if applicable) across all channels and RB allocations measured with the EUT in primary mechanical mode, and (if applicable) in non-primary mechanical modes as reference information.

TABLE 5-31 LTE CARRIER AGGREGATION MODE (2 DOWNLINK CARRIERS, 1 UPLINK CARRIER) TRP CRITERIA
TABLE FOR THE PRIMARY MECHANICAL MODE¹

Carrier Aggregation Combination	Device Held to Head for Voice	Device Width (mm) ²	Free Space	HL and HR
CA_2A-2A	Yes ³	≤72	TBD	TBD
	Yes ³	>72	TBD	TBD
	No ⁴	All	TBD	N/A
CA_2A-4A	Yes ³	≤72	TBD	TBD
	Yes ³	>72	TBD	TBD
	No ⁴	All	TBD	N/A

TABLE 5-31 LTE CARRIER AGGREGATION MODE (2 DOWNLINK CARRIERS, 1 UPLINK CARRIER) TRP CRITERIA
TABLE FOR THE PRIMARY MECHANICAL MODE¹

Carrier Aggregation Combination	Device Held to Head for Voice	Device Width (mm) ²	Free Space	HL and HR
CA_2A-5A	Yes ³	≤72	TBD	TBD
	Yes ³	>72	TBD	TBD
	No ⁴	All	TBD	N/A
CA_2A-12A	Yes ³	≤72	TBD	TBD
	Yes ³	>72	TBD	TBD
	No ⁴	All	TBD	N/A
CA_2A-13A	Yes ³	≤72	TBD	TBD
	Yes ³	>72	TBD	TBD
	No ⁴	All	TBD	N/A
CA_2A-17A	Yes ³	≤72	TBD	TBD
	Yes ³	>72	TBD	TBD
	No ⁴	All	TBD	N/A
CA_2A-29A	Yes ³	≤72	TBD	TBD
	Yes ³	>72	TBD	TBD
	No ⁴	All	TBD	N/A
CA_2A-30A	Yes ³	≤72	TBD	TBD
	Yes ³	>72	TBD	TBD
	No ⁴	All	TBD	N/A
CA_2A-48A	Yes ³	≤72	TBD	TBD
	Yes ³	>72	TBD	TBD
	No ⁴	All	TBD	N/A
CA_2A-66A	Yes ³	≤72	TBD	TBD
	Yes ³	>72	TBD	TBD
	No ⁴	All	TBD	N/A
CA_4A-2A	Yes ³	≤72	TBD	TBD
	Yes ³	>72	TBD	TBD
	No ⁴	All	TBD	N/A
CA_4A-4A	Yes ³	≤72	TBD	TBD
	Yes ³	>72	TBD	TBD
	No ⁴	All	TBD	N/A
CA_4A-5A	Yes ³	≤72	TBD	TBD
	Yes ³	>72	TBD	TBD
	No ⁴	All	TBD	N/A

TABLE 5-31 LTE CARRIER AGGREGATION MODE (2 DOWNLINK CARRIERS, 1 UPLINK CARRIER) TRP CRITERIA
TABLE FOR THE PRIMARY MECHANICAL MODE¹

Carrier Aggregation Combination	Device Held to Head for Voice	Device Width (mm) ²	Free Space	HL and HR
CA_4A-12A	Yes ³	≤72	TBD	TBD
	Yes ³	>72	TBD	TBD
	No ⁴	All	TBD	N/A
CA_4A-13A	Yes ³	≤72	TBD	TBD
	Yes ³	>72	TBD	TBD
	No ⁴	All	TBD	N/A
CA_4A-17A	Yes ³	≤72	TBD	TBD
	Yes ³	>72	TBD	TBD
	No ⁴	All	TBD	N/A
CA_4A-29A	Yes ³	≤72	TBD	TBD
	Yes ³	>72	TBD	TBD
	No ⁴	All	TBD	N/A
CA_4A-30A	Yes ³	≤72	TBD	TBD
	Yes ³	>72	TBD	TBD
	No ⁴	All	TBD	N/A
CA_5A-2A	Yes ³	≤72	TBD	TBD
	Yes ³	>72	TBD	TBD
	No ⁴	All	TBD	N/A
CA_5A-4A	Yes ³	≤72	TBD	TBD
	Yes ³	>72	TBD	TBD
	No ⁴	All	TBD	N/A
CA_5B	Yes ³	≤72	TBD	TBD
	Yes ³	>72	TBD	TBD
	No ⁴	All	TBD	N/A
CA_5A-5A	Yes ³	≤72	TBD	TBD
	Yes ³	>72	TBD	TBD
	No ⁴	All	TBD	N/A
CA_5A-30A	Yes ³	≤72	TBD	TBD
	Yes ³	>72	TBD	TBD
	No ⁴	All	TBD	N/A
CA_5A-48A	Yes ³	≤72	TBD	TBD
	Yes ³	>72	TBD	TBD
	No ⁴	All	TBD	N/A

TABLE 5-31 LTE CARRIER AGGREGATION MODE (2 DOWNLINK CARRIERS, 1 UPLINK CARRIER) TRP CRITERIA
TABLE FOR THE PRIMARY MECHANICAL MODE¹

Carrier Aggregation Combination	Device Held to Head for Voice	Device Width (mm) ²	Free Space	HL and HR
CA_5A-66A	Yes ³	≤72	TBD	TBD
	Yes ³	>72	TBD	TBD
	No ⁴	All	TBD	N/A
CA_12A-2A	Yes ³	≤72	TBD	TBD
	Yes ³	>72	TBD	TBD
	No ⁴	All	TBD	N/A
CA_12A-4A	Yes ³	≤72	TBD	TBD
	Yes ³	>72	TBD	TBD
	No ⁴	All	TBD	N/A
CA_12A-30A	Yes ³	≤72	TBD	TBD
	Yes ³	>72	TBD	TBD
	No ⁴	All	TBD	N/A
CA_12A-66A	Yes ³	≤72	TBD	TBD
	Yes ³	>72	TBD	TBD
	No ⁴	All	TBD	N/A
CA_13A-2A	Yes ³	≤72	TBD	TBD
	Yes ³	>72	TBD	TBD
	No ⁴	All	TBD	N/A
CA_13A-4A	Yes ³	≤72	TBD	TBD
	Yes ³	>72	TBD	TBD
	No ⁴	All	TBD	N/A
CA_13A-48A	Yes ³	≤72	TBD	TBD
	Yes ³	>72	TBD	TBD
	No ⁴	All	TBD	N/A
CA_13A-66A	Yes ³	≤72	TBD	TBD
	Yes ³	>72	TBD	TBD
	No ⁴	All	TBD	N/A
CA_17A-2A	Yes ³	≤72	TBD	TBD
	Yes ³	>72	TBD	TBD
	No ⁴	All	TBD	N/A
CA_17A-4A	Yes ³	≤72	TBD	TBD
	Yes ³	>72	TBD	TBD
	No ⁴	All	TBD	N/A

TABLE 5-31 LTE CARRIER AGGREGATION MODE (2 DOWNLINK CARRIERS, 1 UPLINK CARRIER) TRP CRITERIA
TABLE FOR THE PRIMARY MECHANICAL MODE¹

Carrier Aggregation Combination	Device Held to Head for Voice	Device Width (mm) ²	Free Space	HL and HR
CA_17A-66A	Yes ³	≤72	TBD	TBD
	Yes ³	>72	TBD	TBD
	No ⁴	All	TBD	N/A
CA_25A-25A	Yes ³	≤72	TBD	TBD
	Yes ³	>72	TBD	TBD
	No ⁴	All	TBD	N/A
CA_25A-26A	Yes ³	≤72	TBD	TBD
	Yes ³	>72	TBD	TBD
	No ⁴	All	TBD	N/A
CA_25A-41A	Yes ³	≤72	TBD	TBD
	Yes ³	>72	TBD	TBD
	No ⁴	All	TBD	N/A
CA_26A-25A	Yes ³	≤72	TBD	TBD
	Yes ³	>72	TBD	TBD
	No ⁴	All	TBD	N/A
CA_26A-41A	Yes ³	≤72	TBD	TBD
	Yes ³	>72	TBD	TBD
	No ⁴	All	TBD	N/A
CA_30A-2A	Yes ³	≤72	TBD	TBD
	Yes ³	>72	TBD	TBD
	No ⁴	All	TBD	N/A
CA_30A-4A	Yes ³	≤72	TBD	TBD
	Yes ³	>72	TBD	TBD
	No ⁴	All	TBD	N/A
CA_30A-5A	Yes ³	≤72	TBD	TBD
	Yes ³	>72	TBD	TBD
	No ⁴	All	TBD	N/A
CA_30A-12A	Yes ³	≤72	TBD	TBD
	Yes ³	>72	TBD	TBD
	No ⁴	All	TBD	N/A
CA_30A-29A	Yes ³	≤72	TBD	TBD
	Yes ³	>72	TBD	TBD
	No ⁴	All	TBD	N/A

TABLE 5-31 LTE CARRIER AGGREGATION MODE (2 DOWNLINK CARRIERS, 1 UPLINK CARRIER) TRP CRITERIA
TABLE FOR THE PRIMARY MECHANICAL MODE¹

Carrier Aggregation Combination	Device Held to Head for Voice	Device Width (mm) ²	Free Space	HL and HR
CA_30A-66A	Yes ³	≤72	TBD	TBD
	Yes ³	>72	TBD	TBD
	No ⁴	All	TBD	N/A
CA_41A-25A	Yes ³	≤72	TBD	TBD
	Yes ³	>72	TBD	TBD
	No ⁴	All	TBD	N/A
CA_41A-26A	Yes ³	≤72	TBD	TBD
	Yes ³	>72	TBD	TBD
	No ⁴	All	TBD	N/A
CA_41C	Yes ³	≤72	TBD	TBD
	Yes ³	>72	TBD	TBD
	No ⁴	All	TBD	N/A
CA_41A-41A	Yes ³	≤72	TBD	TBD
	Yes ³	>72	TBD	TBD
	No ⁴	All	TBD	N/A
CA_48A-2A	Yes ³	≤72	TBD	TBD
	Yes ³	>72	TBD	TBD
	No ⁴	All	TBD	N/A
CA_48A-5A	Yes ³	≤72	TBD	TBD
	Yes ³	>72	TBD	TBD
	No ⁴	All	TBD	N/A
CA_48A-13A	Yes ³	≤72	TBD	TBD
	Yes ³	>72	TBD	TBD
	No ⁴	All	TBD	N/A
CA_48A-66A	Yes ³	≤72	TBD	TBD
	Yes ³	>72	TBD	TBD
	No ⁴	All	TBD	N/A
CA_66A-2A	Yes ³	≤72	TBD	TBD
	Yes ³	>72	TBD	TBD
	No ⁴	All	TBD	N/A
CA_66A-5A	Yes ³	≤72	TBD	TBD
	Yes ³	>72	TBD	TBD
	No ⁴	All	TBD	N/A

TABLE 5-31 LTE CARRIER AGGREGATION MODE (2 DOWNLINK CARRIERS, 1 UPLINK CARRIER) TRP CRITERIA
TABLE FOR THE PRIMARY MECHANICAL MODE¹

Carrier Aggregation Combination	Device Held to Head for Voice	Device Width (mm) ²	Free Space	HL and HR
CA_66A-12A	Yes ³	≤72	TBD	TBD
	Yes ³	>72	TBD	TBD
	No ⁴	All	TBD	N/A
CA_66A-13A	Yes ³	≤72	TBD	TBD
	Yes ³	>72	TBD	TBD
	No ⁴	All	TBD	N/A
CA_66A-17A	Yes ³	≤72	TBD	TBD
	Yes ³	>72	TBD	TBD
	No ⁴	All	TBD	N/A
CA_66A-29A	Yes ³	≤72	TBD	TBD
	Yes ³	>72	TBD	TBD
	No ⁴	All	TBD	N/A
CA_66A-30A	Yes ³	≤72	TBD	TBD
	Yes ³	>72	TBD	TBD
	No ⁴	All	TBD	N/A
CA_66A-48A	Yes ³	≤72	TBD	TBD
	Yes ³	>72	TBD	TBD
	No ⁴	All	TBD	N/A
CA_66C	Yes ³	≤72	TBD	TBD
	Yes ³	>72	TBD	TBD
	No ⁴	All	TBD	N/A
CA_66A-66A	Yes ³	≤72	TBD	TBD
	Yes ³	>72	TBD	TBD
	No ⁴	All	TBD	N/A
CA_70C	Yes ³	≤72	TBD	TBD
	Yes ³	>72	TBD	TBD
	No ⁴	All	TBD	N/A

Note 1: Primary Mechanical Mode refers to device configured in preferred mode per manufacturer instructions (typically means antenna extended, fold or portrait slide open, but depends on form factor).

Note 2: Differences between requirements for devices wider and narrower than 72 mm reflect observed differences in OTA performance with different hand phantoms of up to 6 dB.

Note 3: "Yes" applies if the device supports voice operation in the talking position against the head in LTE mode.

Note 4: "No" would be applicable to data-centric devices that are not held up against the head, e.g., embedded laptop solutions.

5.13 LTE Three Downlink Carrier Aggregation (Single Uplink Carrier)

The number and type of measurements required to support TRP performance evaluation shall be determined based on the CA specific test requirements for carrier aggregation testing as described in [Appendix O.8.1](#).

5.13.1 Test Procedure

The test procedure for three downlink carrier aggregation with a single uplink carrier is the same as the test procedure for two downlink carrier aggregation with a single uplink carrier (per Section 5.12) with the exception that there are two SCCs.

Tests shall be carried out for different carrier aggregation frequency combinations and RB allocations across the bands supported by the EUT, as defined in [Table 5-32](#). Since only the PCC is being tested, there is no need to swap the SCCs. The SCCs have been chosen, in general, to maximize the bandwidth spanned by the antenna.

In order to reduce the need for communication tester upgrades or additions, testing LTE CA 3 DL combinations in stand-alone LTE is allowed under certain conditions as long as the antenna tuning is set according to the CA 3 DL combination that is being evaluated. The PCC TRP for a 3 DL CA combination may be tested in stand-alone LTE mode with the antenna tuned for operation in the 3 DL CA combination.

For example, when evaluating an interband 3 DL CA case, CA_xA-yA-zA, where x, y and z are the LTE bands and the PCC is in LTE x, then the following tests are permitted:

1. TRP for x in CA_xA-yA-zA may be tested in stand-alone LTE x with the antenna tuned for operation in CA_xA-yA-zA.

Device manufacturers using dynamically tuned antennas should in general have a method of altering the antenna tuning in order to do the necessary antenna tuning optimization during the R&D phase. In general, the settings for the antenna tuner are stored in a tuning file. Consequently, the antenna tuning can be modified by writing a different tuning file into the device. All the stand-alone LTE bands could be tested using the normal tuning file. A second tuning file for testing the 2 DL CA modes could be created where the antenna tuner settings for the stand-alone LTE bands are changed to the antenna tuner settings for the associated 2 DL CA mode. A third tuning file for testing the 3 DL CA modes could be created where the antenna tuner settings for the stand-alone LTE bands are changed to the antenna tuner settings for the associated 3 DL CA mode.

TABLE 5-32 LTE CARRIER AGGREGATION MODE (3 DOWNLINK CARRIERS, 1 UPLINK CARRIER) TRP MEASUREMENTS TABLE FOR THE PRIMARY MECHANICAL MODE¹

Carrier Aggregation Combination	Primary Component Carrier (PCC) Band	Secondary Component Carriers (SCC1/ SCC2) Bands	PCC BW (MHz)	SCC BWs (MHz)	PCC UL Channel	SCC DL Channels	PCC UL RB Allocation	PCC DL RB Allocation	SCC DL RB Allocations
CA_2A-2A-4A ²	2	SCC1=2 SCC2=4	10	SCC1=10 SCC2=10	18650	SCC1=900 SCC2=2350	12 RB with RBstart=0	N/A ³	N/A ³
					18900	SCC1=1150 SCC2=2350	12 RB with RBstart=19	N/A ³	N/A ³
					19150	SCC1=650 SCC2=2350	12 RB with RBstart=38	N/A ³	N/A ³
CA_2A-2A-5A ²	2	SCC1=2 SCC2=5	10	SCC1=10 SCC2=10	18650	SCC1=900 SCC2=2450	12 RB with RBstart=0	N/A ³	N/A ³
					18900	SCC1=1150 SCC2=2450	12 RB with RBstart=19	N/A ³	N/A ³
					19150	SCC1=650 SCC2=2450	12 RB with RBstart=38	N/A ³	N/A ³
CA_2A-2A-12A ²	2	SCC1=2 SCC2=12	10	SCC1=10 SCC2=5	18650	SCC1=900 SCC2=5035	12 RB with RBstart=0	N/A ³	N/A ³
					18900	SCC1=1150 SCC2=5035	12 RB with RBstart=19	N/A ³	N/A ³
					19150	SCC1=650 SCC2=5035	12 RB with RBstart=38	N/A ³	N/A ³
CA_2A-2A-13A ²	2	SCC1=2 SCC2=13	10	SCC1=10 SCC2=10	18650	SCC1=900 SCC2=5230	12 RB with RBstart=0	N/A ³	N/A ³
					18900	SCC1=1150 SCC2=5230	12 RB with RBstart=19	N/A ³	N/A ³
					19150	SCC1=650 SCC2=5230	12 RB with RBstart=38	N/A ³	N/A ³
CA_2A-2A-66A ²	2	SCC1=2 SCC2=66	10	SCC1=10 SCC2=10	18650	SCC1=900 SCC2=67286	12 RB with RBstart=0	N/A ³	N/A ³
					18900	SCC1=1150 SCC2=67286	12 RB with RBstart=19	N/A ³	N/A ³
					19150	SCC1=650 SCC2=67286	12 RB with RBstart=38	N/A ³	N/A ³
CA_2A-4A-4A ⁴	2	SCC1=4 SCC2=4	10	SCC1=10 SCC2=10	18650	SCC1=2000 SCC2=2350	12 RB with RBstart=0	N/A ³	N/A ³
					18900	SCC1=2000 SCC2=2350	12 RB with RBstart=19	N/A ³	N/A ³
					19150	SCC1=2000 SCC2=2350	12 RB with RBstart=38	N/A ³	N/A ³
CA_2A-4A-5A ⁴	2	SCC1=4 SCC2=5	10	SCC1=10 SCC2=10	18650	SCC1=2350 SCC2=2450	12 RB with RBstart=0	N/A ³	N/A ³
					18900	SCC1=2350 SCC2=2450	12 RB with RBstart=19	N/A ³	N/A ³
					19150	SCC1=2350 SCC2=2450	12 RB with RBstart=38	N/A ³	N/A ³

TABLE 5-32 LTE CARRIER AGGREGATION MODE (3 DOWNLINK CARRIERS, 1 UPLINK CARRIER) TRP MEASUREMENTS TABLE FOR THE PRIMARY MECHANICAL MODE¹

Carrier Aggregation Combination	Primary Component Carrier (PCC) Band	Secondary Component Carriers (SCC1/SCC2) Bands	PCC BW (MHz)	SCC BWs (MHz)	PCC UL Channel	SCC DL Channels	PCC UL RB Allocation	PCC DL RB Allocation	SCC DL RB Allocations
CA_2A-4A-12A ⁴	2	SCC1=4 SCC2=12	10	SCC1=10 SCC2=5	18650	SCC1=2350 SCC2=5035	12 RB with RBstart=0	N/A ³	N/A ³
					18900	SCC1=2350 SCC2=5035	12 RB with RBstart=19	N/A ³	N/A ³
					19150	SCC1=2350 SCC2=5035	12 RB with RBstart=38	N/A ³	N/A ³
CA_2A-4A-13A ⁴	2	SCC1=4 SCC2=13	10	SCC1=10 SCC2=10	18650	SCC1=2350 SCC2=5230	12 RB with RBstart=0	N/A ³	N/A ³
					18900	SCC1=2350 SCC2=5230	12 RB with RBstart=19	N/A ³	N/A ³
					19150	SCC1=2350 SCC2=5230	12 RB with RBstart=38	N/A ³	N/A ³
CA_2A-5A-30A	2	SCC1=5 SCC2=30	10	SCC1=10 SCC2=10	18650	SCC1=2450 SCC2=9820	12 RB with RBstart=0	N/A ³	N/A ³
					18900	SCC1=2450 SCC2=9820	12 RB with RBstart=19	N/A ³	N/A ³
					19150	SCC1=2450 SCC2=9820	12 RB with RBstart=38	N/A ³	N/A ³
CA_2A-5A-48A	2	SCC1=5 SCC2=48	10	SCC1=10 SCC2=10	18650	SCC1=2450 SCC2=56690	12 RB with RBstart=0	N/A ³	N/A ³
					18900	SCC1=2450 SCC2=56690	12 RB with RBstart=19	N/A ³	N/A ³
					19150	SCC1=2450 SCC2=56690	12 RB with RBstart=38	N/A ³	N/A ³
CA_2A-5A-66A ⁴	2	SCC1=5 SCC2=66	10	SCC1=10 SCC2=10	18650	SCC1=2450 SCC2=67286	12 RB with RBstart=0	N/A ³	N/A ³
					18900	SCC1=2450 SCC2=67286	12 RB with RBstart=19	N/A ³	N/A ³
					19150	SCC1=2450 SCC2=67286	12 RB with RBstart=38	N/A ³	N/A ³
CA_2A-12A-30A	2	SCC1=12 SCC2=30	10	SCC1=5 SCC2=10	18650	SCC1=5035 SCC2=9820	12 RB with RBstart=0	N/A ³	N/A ³
					18900	SCC1=5035 SCC2=9820	12 RB with RBstart=19	N/A ³	N/A ³
					19150	SCC1=5035 SCC2=9820	12 RB with RBstart=38	N/A ³	N/A ³
CA_2A-12A-66A ⁴	2	SCC1=12 SCC2=66	10	SCC1=5 SCC2=10	18650	SCC1=5035 SCC2=67286	12 RB with RBstart=0	N/A ³	N/A ³
					18900	SCC1=5035 SCC2=67286	12 RB with RBstart=19	N/A ³	N/A ³
					19150	SCC1=5035 SCC2=67286	12 RB with RBstart=38	N/A ³	N/A ³

TABLE 5-32 LTE CARRIER AGGREGATION MODE (3 DOWNLINK CARRIERS, 1 UPLINK CARRIER) TRP MEASUREMENTS TABLE FOR THE PRIMARY MECHANICAL MODE¹

Carrier Aggregation Combination	Primary Component Carrier (PCC) Band	Secondary Component Carriers (SCC1/SCC2) Bands	PCC BW (MHz)	SCC BWs (MHz)	PCC UL Channel	SCC DL Channels	PCC UL RB Allocation	PCC DL RB Allocation	SCC DL RB Allocations
CA_2A-13A-48A	2	SCC1=13 SCC2=48	10	SCC1=10 SCC2=10	18650	SCC1=5230 SCC2=56690	12 RB with RBstart=0	N/A ³	N/A ³
					18900	SCC1=5230 SCC2=56690	12 RB with RBstart=19	N/A ³	N/A ³
					19150	SCC1=5230 SCC2=56690	12 RB with RBstart=38	N/A ³	N/A ³
CA_2A-13A-66A ⁴	2	SCC1=13 SCC2=66	10	SCC1=10 SCC2=10	18650	SCC1=5230 SCC2=67286	12 RB with RBstart=0	N/A ³	N/A ³
					18900	SCC1=5230 SCC2=67286	12 RB with RBstart=19	N/A ³	N/A ³
					19150	SCC1=5230 SCC2=67286	12 RB with RBstart=38	N/A ³	N/A ³
CA_2A-29A-30A	2	SCC1=29 SCC2=30	10	SCC1=10 SCC2=10	18650	SCC1=9720 SCC2=9820	12 RB with RBstart=0	N/A ³	N/A ³
					18900	SCC1=9720 SCC2=9820	12 RB with RBstart=19	N/A ³	N/A ³
					19150	SCC1=9720 SCC2=9820	12 RB with RBstart=38	N/A ³	N/A ³
CA_2A-48A-66A ⁴	2	SCC1=48 SCC2=66	10	SCC1=10 SCC2=10	18650	SCC1=56690 SCC2=66486	12 RB with RBstart=0	N/A ³	N/A ³
					18900	SCC1=56690 SCC2=66486	12 RB with RBstart=19	N/A ³	N/A ³
					19150	SCC1=56690 SCC2=66486	12 RB with RBstart=38	N/A ³	N/A ³
CA_2A-66C ^{4,5}	2	SCC1=66 SCC2=66	10	SCC1=10 SCC2=20	18650	SCC1=67086 SCC2=67230	12 RB with RBstart=0	N/A ³	N/A ³
					18900	SCC1=67086 SCC2=67230	12 RB with RBstart=19	N/A ³	N/A ³
					19150	SCC1=67086 SCC2=67230	12 RB with RBstart=38	N/A ³	N/A ³
CA_2A-66A-66A ⁴	2	SCC1=66 SCC2=66	10	SCC1=10 SCC2=10	18650	SCC1=66486 SCC2=67286	12 RB with RBstart=0	N/A ³	N/A ³
					18900	SCC1=66486 SCC2=67286	12 RB with RBstart=19	N/A ³	N/A ³
					19150	SCC1=66486 SCC2=67286	12 RB with RBstart=38	N/A ³	N/A ³
CA_4A-2A-4A	4	SCC1=2 SCC2=4	10	SCC1=10 SCC2=10	20000	SCC1=650 SCC2=2175	12 RB with RBstart=0	N/A ³	N/A ³
					20175	SCC1=650 SCC2=2350	12 RB with RBstart=19	N/A ³	N/A ³
					20350	SCC1=650 SCC2=2000	12 RB with RBstart=38	N/A ³	N/A ³

TABLE 5-32 LTE CARRIER AGGREGATION MODE (3 DOWNLINK CARRIERS, 1 UPLINK CARRIER) TRP MEASUREMENTS TABLE FOR THE PRIMARY MECHANICAL MODE¹

Carrier Aggregation Combination	Primary Component Carrier (PCC) Band	Secondary Component Carriers (SCC1/SCC2) Bands	PCC BW (MHz)	SCC BWs (MHz)	PCC UL Channel	SCC DL Channels	PCC UL RB Allocation	PCC DL RB Allocation	SCC DL RB Allocations
CA_4A-2A-5A ⁴	4	SCC1=2 SCC2=5	10	SCC1=10 SCC2=10	20000	SCC1=650 SCC2=2450	12 RB with RBstart=0	N/A ³	N/A ³
					20175	SCC1=650 SCC2=2450	12 RB with RBstart=19	N/A ³	N/A ³
					20350	SCC1=650 SCC2=2450	12 RB with RBstart=38	N/A ³	N/A ³
CA_4A-2A-12A ⁴	4	SCC1=2 SCC2=12	10	SCC1=10 SCC2=5	20000	SCC1=650 SCC2=5035	12 RB with RBstart=0	N/A ³	N/A ³
					20175	SCC1=650 SCC2=5035	12 RB with RBstart=19	N/A ³	N/A ³
					20350	SCC1=650 SCC2=5035	12 RB with RBstart=38	N/A ³	N/A ³
CA_4A-2A-13A ⁴	4	SCC1=2 SCC2=13	10	SCC1=10 SCC2=10	20000	SCC1=650 SCC2=5230	12 RB with RBstart=0	N/A ³	N/A ³
					20175	SCC1=650 SCC2=5230	12 RB with RBstart=19	N/A ³	N/A ³
					20350	SCC1=650 SCC2=5230	12 RB with RBstart=38	N/A ³	N/A ³
CA_4A-4A-5A ⁴	4	SCC1=4 SCC2=5	10	SCC1=10 SCC2=10	20000	SCC1=2175 SCC2=2450	12 RB with RBstart=0	N/A ³	N/A ³
					20175	SCC1=2350 SCC2=2450	12 RB with RBstart=19	N/A ³	N/A ³
					20350	SCC1=2000 SCC2=2450	12 RB with RBstart=38	N/A ³	N/A ³
CA_4A-4A-12A ⁴	4	SCC1=4 SCC2=12	10	SCC1=10 SCC2=5	20000	SCC1=2175 SCC2=5035	12 RB with RBstart=0	N/A ³	N/A ³
					20175	SCC1=2350 SCC2=5035	12 RB with RBstart=19	N/A ³	N/A ³
					20350	SCC1=2000 SCC2=5035	12 RB with RBstart=38	N/A ³	N/A ³
CA_4A-4A-13A ⁴	4	SCC1=4 SCC2=13	10	SCC1=10 SCC2=10	20000	SCC1=2175 SCC2=5230	12 RB with RBstart=0	N/A ³	N/A ³
					20175	SCC1=2350 SCC2=5230	12 RB with RBstart=19	N/A ³	N/A ³
					20350	SCC1=2000 SCC2=5230	12 RB with RBstart=38	N/A ³	N/A ³
CA_4A-5A-30A ⁴	4	SCC1=5 SCC2=30	10	SCC1=10 SCC2=10	20000	SCC1=2450 SCC2=9820	12 RB with RBstart=0	N/A ³	N/A ³
					20175	SCC1=2450 SCC2=9820	12 RB with RBstart=19	N/A ³	N/A ³
					20350	SCC1=2450 SCC2=9820	12 RB with RBstart=38	N/A ³	N/A ³

TABLE 5-32 LTE CARRIER AGGREGATION MODE (3 DOWNLINK CARRIERS, 1 UPLINK CARRIER) TRP MEASUREMENTS TABLE FOR THE PRIMARY MECHANICAL MODE¹

Carrier Aggregation Combination	Primary Component Carrier (PCC) Band	Secondary Component Carriers (SCC1/SCC2) Bands	PCC BW (MHz)	SCC BWs (MHz)	PCC UL Channel	SCC DL Channels	PCC UL RB Allocation	PCC DL RB Allocation	SCC DL RB Allocations
CA_4A-12A-30A ⁴	4	SCC1=12 SCC2=30	10	SCC1=5 SCC2=10	20000	SCC1=5035 SCC2=9820	12 RB with RBstart=0	N/A ³	N/A ³
					20175	SCC1=5035 SCC2=9820	12 RB with RBstart=19	N/A ³	N/A ³
					20350	SCC1=5035 SCC2=9820	12 RB with RBstart=38	N/A ³	N/A ³
CA_4A-29A-30A ⁴	4	SCC1=29 SCC2=30	10	SCC1=10 SCC2=10	20000	SCC1=9720 SCC2=9820	12 RB with RBstart=0	N/A ³	N/A ³
					20175	SCC1=9720 SCC2=9820	12 RB with RBstart=19	N/A ³	N/A ³
					20350	SCC1=9720 SCC2=9820	12 RB with RBstart=38	N/A ³	N/A ³
CA_5A-2A-2A	5	SCC1=2 SCC2=2	10	SCC1=10 SCC2=10	20450	SCC1=650 SCC2=1150	12 RB with RBstart=0	N/A ³	N/A ³
					20525	SCC1=650 SCC2=1150	12 RB with RBstart=19	N/A ³	N/A ³
					20600	SCC1=650 SCC2=1150	12 RB with RBstart=38	N/A ³	N/A ³
CA_5A-2A-4A ⁴	5	SCC1=2 SCC2=4	10	SCC1=10 SCC2=10	20450	SCC1=650 SCC2=2350	12 RB with RBstart=0	N/A ³	N/A ³
					20525	SCC1=650 SCC2=2350	12 RB with RBstart=19	N/A ³	N/A ³
					20600	SCC1=650 SCC2=2350	12 RB with RBstart=38	N/A ³	N/A ³
CA_5A-2A-30A	5	SCC1=2 SCC2=30	10	SCC1=10 SCC2=10	20450	SCC1=650 SCC2=9820	12 RB with RBstart=0	N/A ³	N/A ³
					20525	SCC1=650 SCC2=9820	12 RB with RBstart=19	N/A ³	N/A ³
					20600	SCC1=650 SCC2=9820	12 RB with RBstart=38	N/A ³	N/A ³
CA_5A-2A-48A	5	SCC1=2 SCC2=48	10	SCC1=10 SCC2=10	20450	SCC1=650 SCC2=56690	12 RB with RBstart=0	N/A ³	N/A ³
					20525	SCC1=650 SCC2=56690	12 RB with RBstart=19	N/A ³	N/A ³
					20600	SCC1=650 SCC2=56690	12 RB with RBstart=38	N/A ³	N/A ³
CA_5A-2A-66A ⁴	5	SCC1=2 SCC2=66	10	SCC1=10 SCC2=10	20450	SCC1=650 SCC2=67286	12 RB with RBstart=0	N/A ³	N/A ³
					20525	SCC1=650 SCC2=67286	12 RB with RBstart=19	N/A ³	N/A ³
					20600	SCC1=650 SCC2=67286	12 RB with RBstart=38	N/A ³	N/A ³

TABLE 5-32 LTE CARRIER AGGREGATION MODE (3 DOWNLINK CARRIERS, 1 UPLINK CARRIER) TRP MEASUREMENTS TABLE FOR THE PRIMARY MECHANICAL MODE¹

Carrier Aggregation Combination	Primary Component Carrier (PCC) Band	Secondary Component Carriers (SCC1/SCC2) Bands	PCC BW (MHz)	SCC BWs (MHz)	PCC UL Channel	SCC DL Channels	PCC UL RB Allocation	PCC DL RB Allocation	SCC DL RB Allocations
CA_5A-4A-4A ⁴	5	SCC1=4 SCC2=4	10	SCC1=10 SCC2=10	20450	SCC1=2000 SCC2=2350	12 RB with RBstart=0	N/A ³	N/A ³
					20525	SCC1=2000 SCC2=2350	12 RB with RBstart=19	N/A ³	N/A ³
					20600	SCC1=2000 SCC2=2350	12 RB with RBstart=38	N/A ³	N/A ³
CA_5A-4A-30A ⁴	5	SCC1=4 SCC2=30	10	SCC1=10 SCC2=10	20450	SCC1=2000 SCC2=9820	12 RB with RBstart=0	N/A ³	N/A ³
					20525	SCC1=2000 SCC2=9820	12 RB with RBstart=19	N/A ³	N/A ³
					20600	SCC1=2000 SCC2=9820	12 RB with RBstart=38	N/A ³	N/A ³
CA_5A-5A-66A ^{2,4}	5	SCC1=5 SCC2=66	5	SCC1=5 SCC2=10	20425	SCC1=2525 SCC2=67286	8 RB with RBstart=0	N/A ³	N/A ³
					20525	SCC1=2625 SCC2=67286	8 RB with RBstart=8	N/A ³	N/A ³
					20625	SCC1=2425 SCC2=67286	8 RB with RBstart=17	N/A ³	N/A ³
CA_5A-29A-30A	5	SCC1=29 SCC2=30	10	SCC1=10 SCC2=10	20450	SCC1=9720 SCC2=9820	12 RB with RBstart=0	N/A ³	N/A ³
					20525	SCC1=9720 SCC2=9820	12 RB with RBstart=19	N/A ³	N/A ³
					20600	SCC1=9720 SCC2=9820	12 RB with RBstart=38	N/A ³	N/A ³
CA_5A-30A-66A ⁴	5	SCC1=30 SCC2=66	10	SCC1=10 SCC2=10	20450	SCC1=9820 SCC2=66486	12 RB with RBstart=0	N/A ³	N/A ³
					20525	SCC1=9820 SCC2=66486	12 RB with RBstart=19	N/A ³	N/A ³
					20600	SCC1=9820 SCC2=66486	12 RB with RBstart=38	N/A ³	N/A ³
CA_5A-48A-66A	5	SCC1=48 SCC2=66	10	SCC1=10 SCC2=10	20450	SCC1=56690 SCC2=66486	12 RB with RBstart=0	N/A ³	N/A ³
					20525	SCC1=56690 SCC2=66486	12 RB with RBstart=19	N/A ³	N/A ³
					20600	SCC1=56690 SCC2=66486	12 RB with RBstart=38	N/A ³	N/A ³
CA_5A-66C ^{4,5}	5	SCC1=66 SCC2=66	10	SCC1=10 SCC2=20	20450	SCC1=67086 SCC2=67230	12 RB with RBstart=0	N/A ³	N/A ³
					20525	SCC1=67086 SCC2=67230	12 RB with RBstart=19	N/A ³	N/A ³
					20600	SCC1=67086 SCC2=67230	12 RB with RBstart=38	N/A ³	N/A ³

TABLE 5-32 LTE CARRIER AGGREGATION MODE (3 DOWNLINK CARRIERS, 1 UPLINK CARRIER) TRP MEASUREMENTS TABLE FOR THE PRIMARY MECHANICAL MODE¹

Carrier Aggregation Combination	Primary Component Carrier (PCC) Band	Secondary Component Carriers (SCC1/SCC2) Bands	PCC BW (MHz)	SCC BWs (MHz)	PCC UL Channel	SCC DL Channels	PCC UL RB Allocation	PCC DL RB Allocation	SCC DL RB Allocations
CA_5A-66A-66A ⁴	5	SCC1=66 SCC2=66	10	SCC1=10 SCC2=10	20450	SCC1=66486 SCC2=67286	12 RB with RBstart=0	N/A ³	N/A ³
					20525	SCC1=66486 SCC2=67286	12 RB with RBstart=19	N/A ³	N/A ³
					20600	SCC1=66486 SCC2=67286	12 RB with RBstart=38	N/A ³	N/A ³
CA_12A-2A-2A	12	SCC1=2 SCC2=2	5	SCC1=10 SCC2=10	23035	SCC1=650 SCC2=1150	8 RB with RBstart=0	N/A ³	N/A ³
					23095	SCC1=650 SCC2=1150	8 RB with RBstart=8	N/A ³	N/A ³
					23155	SCC1=650 SCC2=1150	8 RB with RBstart=17	N/A ³	N/A ³
CA_12A-2A-4A ⁴	12	SCC1=2 SCC2=4	5	SCC1=10 SCC2=10	23035	SCC1=650 SCC2=2350	8 RB with RBstart=0	N/A ³	N/A ³
					23095	SCC1=650 SCC2=2350	8 RB with RBstart=8	N/A ³	N/A ³
					23155	SCC1=650 SCC2=2350	8 RB with RBstart=17	N/A ³	N/A ³
CA_12A-2A-30A	12	SCC1=2 SCC2=30	5	SCC1=10 SCC2=10	23035	SCC1=650 SCC2=9820	8 RB with RBstart=0	N/A ³	N/A ³
					23095	SCC1=650 SCC2=9820	8 RB with RBstart=8	N/A ³	N/A ³
					23155	SCC1=650 SCC2=9820	8 RB with RBstart=17	N/A ³	N/A ³
CA_12A-2A-66A ^{2,4}	12	SCC1=2 SCC2=66	5	SCC1=10 SCC2=10	23035	SCC1=650 SCC2=67286	8 RB with RBstart=0	N/A ³	N/A ³
					23095	SCC1=650 SCC2=67286	8 RB with RBstart=8	N/A ³	N/A ³
					23155	SCC1=650 SCC2=67286	8 RB with RBstart=17	N/A ³	N/A ³
CA_12A-4A-4A ^{2,4}	12	SCC1=4 SCC2=4	5	SCC1=10 SCC2=10	23035	SCC1=2000 SCC2=2350	8 RB with RBstart=0	N/A ³	N/A ³
					23095	SCC1=2000 SCC2=2350	8 RB with RBstart=8	N/A ³	N/A ³
					23155	SCC1=2000 SCC2=2350	8 RB with RBstart=17	N/A ³	N/A ³
CA_12A-4A-30A ^{2,4}	12	SCC1=4 SCC2=30	5	SCC1=10 SCC2=10	23035	SCC1=2000 SCC2=9820	8 RB with RBstart=0	N/A ³	N/A ³
					23095	SCC1=2000 SCC2=9820	8 RB with RBstart=8	N/A ³	N/A ³
					23155	SCC1=2000 SCC2=9820	8 RB with RBstart=17	N/A ³	N/A ³

TABLE 5-32 LTE CARRIER AGGREGATION MODE (3 DOWNLINK CARRIERS, 1 UPLINK CARRIER) TRP MEASUREMENTS TABLE FOR THE PRIMARY MECHANICAL MODE¹

Carrier Aggregation Combination	Primary Component Carrier (PCC) Band	Secondary Component Carriers (SCC1/SCC2) Bands	PCC BW (MHz)	SCC BWs (MHz)	PCC UL Channel	SCC DL Channels	PCC UL RB Allocation	PCC DL RB Allocation	SCC DL RB Allocations
CA_12A-29A-66A ^{2,4}	12	SCC1=29 SCC2=66	5	SCC1=10 SCC2=10	23035	SCC1=9720 SCC2=67286	8 RB with RBstart=0	N/A ³	N/A ³
					23095	SCC1=9720 SCC2=67286	8 RB with RBstart=8	N/A ³	N/A ³
					23155	SCC1=9720 SCC2=67286	8 RB with RBstart=17	N/A ³	N/A ³
CA_12A-30A-66A ^{2,4}	12	SCC1=30 SCC2=66	5	SCC1=10 SCC2=10	23035	SCC1=9820 SCC2=66486	8 RB with RBstart=0	N/A ³	N/A ³
					23095	SCC1=9820 SCC2=66486	8 RB with RBstart=8	N/A ³	N/A ³
					23155	SCC1=9820 SCC2=66486	8 RB with RBstart=17	N/A ³	N/A ³
CA_12A-66C ^{2,4,5}	12	SCC1=66 SCC2=66	5	SCC1=10 SCC2=20	23035	SCC1=67086 SCC2=67230	8 RB with RBstart=0	N/A ³	N/A ³
					23095	SCC1=67086 SCC2=67230	8 RB with RBstart=8	N/A ³	N/A ³
					23155	SCC1=67086 SCC2=67230	8 RB with RBstart=17	N/A ³	N/A ³
CA_12A-66A-66A ^{2,4}	12	SCC1=66 SCC2=66	5	SCC1=10 SCC2=10	23035	SCC1=66486 SCC2=67286	8 RB with RBstart=0	N/A ³	N/A ³
					23095	SCC1=66486 SCC2=67286	8 RB with RBstart=8	N/A ³	N/A ³
					23155	SCC1=66486 SCC2=67286	8 RB with RBstart=17	N/A ³	N/A ³
CA_13A-2A-2A	13	SCC1=2 SCC2=2	10	SCC1=10 SCC2=10	23230	SCC1=650 SCC2=1150	12 RB with RBstart=0	N/A ³	N/A ³
					23230	SCC1=650 SCC2=1150	12 RB with RBstart=19	N/A ³	N/A ³
					23230	SCC1=650 SCC2=1150	12 RB with RBstart=38	N/A ³	N/A ³
CA_13A-2A-4A ⁴	13	SCC1=2 SCC2=4	10	SCC1=10 SCC2=10	23230	SCC1=650 SCC2=2350	12 RB with RBstart=0	N/A ³	N/A ³
					23230	SCC1=650 SCC2=2350	12 RB with RBstart=19	N/A ³	N/A ³
					23230	SCC1=650 SCC2=2350	12 RB with RBstart=38	N/A ³	N/A ³
CA_13A-2A-48A	13	SCC1=2 SCC2=48	10	SCC1=10 SCC2=10	23230	SCC1=650 SCC2=56690	12 RB with RBstart=0	N/A ³	N/A ³
					23230	SCC1=650 SCC2=56690	12 RB with RBstart=19	N/A ³	N/A ³
					23230	SCC1=650 SCC2=56690	12 RB with RBstart=38	N/A ³	N/A ³

TABLE 5-32 LTE CARRIER AGGREGATION MODE (3 DOWNLINK CARRIERS, 1 UPLINK CARRIER) TRP MEASUREMENTS TABLE FOR THE PRIMARY MECHANICAL MODE¹

Carrier Aggregation Combination	Primary Component Carrier (PCC) Band	Secondary Component Carriers (SCC1/SCC2) Bands	PCC BW (MHz)	SCC BWs (MHz)	PCC UL Channel	SCC DL Channels	PCC UL RB Allocation	PCC DL RB Allocation	SCC DL RB Allocations
CA_13A-2A-66A ⁴	13	SCC1=2 SCC2=66	10	SCC1=10 SCC2=10	23230	SCC1=650 SCC2=67286	12 RB with RBstart=0	N/A ³	N/A ³
					23230	SCC1=650 SCC2=67286	12 RB with RBstart=19	N/A ³	N/A ³
					23230	SCC1=650 SCC2=67286	12 RB with RBstart=38	N/A ³	N/A ³
CA_13A-4A-4A ⁴	13	SCC1=4 SCC2=4	10	SCC1=10 SCC2=10	23230	SCC1=2000 SCC2=2350	12 RB with RBstart=0	N/A ³	N/A ³
					23230	SCC1=2000 SCC2=2350	12 RB with RBstart=19	N/A ³	N/A ³
					23230	SCC1=2000 SCC2=2350	12 RB with RBstart=38	N/A ³	N/A ³
CA_13A-48A-66A	13	SCC1=48 SCC2=66	10	SCC1=10 SCC2=10	23230	SCC1=56690 SCC2=66486	12 RB with RBstart=0	N/A ³	N/A ³
					23230	SCC1=56690 SCC2=66486	12 RB with RBstart=19	N/A ³	N/A ³
					23230	SCC1=56690 SCC2=66486	12 RB with RBstart=38	N/A ³	N/A ³
CA_13A-66C ^{4,5}	13	SCC1=66 SCC2=66	10	SCC1=10 SCC2=20	23230	SCC1=67086 SCC2=67230	12 RB with RBstart=0	N/A ³	N/A ³
					23230	SCC1=67086 SCC2=67230	12 RB with RBstart=19	N/A ³	N/A ³
					23230	SCC1=67086 SCC2=67230	12 RB with RBstart=38	N/A ³	N/A ³
CA_13A-66A-66A ⁴	13	SCC1=66 SCC2=66	10	SCC1=10 SCC2=10	23230	SCC1=66486 SCC2=67286	12 RB with RBstart=0	N/A ³	N/A ³
					23230	SCC1=66486 SCC2=67286	12 RB with RBstart=19	N/A ³	N/A ³
					23230	SCC1=66486 SCC2=67286	12 RB with RBstart=38	N/A ³	N/A ³
CA_25A-41C	25	SCC1=41 SCC2=41	5	SCC1=20 SCC2=20	26065	SCC1=39750 SCC2=39948	8 RB with RBstart=0	N/A ³	N/A ³
					26365	SCC1=40620 SCC2=40422	8 RB with RBstart=8	N/A ³	N/A ³
					26665	SCC1=41490 SCC2=41292	8 RB with RBstart=17	N/A ³	N/A ³
CA_30A-2A-5A	30	SCC1=2 SCC2=5	10	SCC1=10 SCC2=10	27710	SCC1=650 SCC2=2450	12 RB with RBstart=0	N/A ³	N/A ³
					27710	SCC1=650 SCC2=2450	12 RB with RBstart=19	N/A ³	N/A ³
					27710	SCC1=650 SCC2=2450	12 RB with RBstart=38	N/A ³	N/A ³

TABLE 5-32 LTE CARRIER AGGREGATION MODE (3 DOWNLINK CARRIERS, 1 UPLINK CARRIER) TRP MEASUREMENTS TABLE FOR THE PRIMARY MECHANICAL MODE¹

Carrier Aggregation Combination	Primary Component Carrier (PCC) Band	Secondary Component Carriers (SCC1/SCC2) Bands	PCC BW (MHz)	SCC BWs (MHz)	PCC UL Channel	SCC DL Channels	PCC UL RB Allocation	PCC DL RB Allocation	SCC DL RB Allocations
CA_30A-2A-12A	30	SCC1=2 SCC2=12	10	SCC1=10 SCC2=5	27710	SCC1=650 SCC2=5035	12 RB with RBstart=0	N/A ³	N/A ³
					27710	SCC1=650 SCC2=5035	12 RB with RBstart=19	N/A ³	N/A ³
					27710	SCC1=650 SCC2=5035	12 RB with RBstart=38	N/A ³	N/A ³
CA_30A-2A-29A	30	SCC1=2 SCC2=29	10	SCC1=10 SCC2=10	27710	SCC1=650 SCC2=9720	12 RB with RBstart=0	N/A ³	N/A ³
					27710	SCC1=650 SCC2=9720	12 RB with RBstart=19	N/A ³	N/A ³
					27710	SCC1=650 SCC2=9720	12 RB with RBstart=38	N/A ³	N/A ³
CA_30A-4A-5A ⁴	30	SCC1=4 SCC2=5	10	SCC1=10 SCC2=10	27710	SCC1=2000 SCC2=2450	12 RB with RBstart=0	N/A ³	N/A ³
					27710	SCC1=2000 SCC2=2450	12 RB with RBstart=19	N/A ³	N/A ³
					27710	SCC1=2000 SCC2=2450	12 RB with RBstart=38	N/A ³	N/A ³
CA_30A-4A-12A ⁴	30	SCC1=4 SCC2=12	10	SCC1=10 SCC2=5	27710	SCC1=2000 SCC2=5035	12 RB with RBstart=0	N/A ³	N/A ³
					27710	SCC1=2000 SCC2=5035	12 RB with RBstart=19	N/A ³	N/A ³
					27710	SCC1=2000 SCC2=5035	12 RB with RBstart=38	N/A ³	N/A ³
CA_30A-4A-29A ⁴	30	SCC1=4 SCC2=29	10	SCC1=10 SCC2=10	27710	SCC1=2000 SCC2=9720	12 RB with RBstart=0	N/A ³	N/A ³
					27710	SCC1=2000 SCC2=9720	12 RB with RBstart=19	N/A ³	N/A ³
					27710	SCC1=2000 SCC2=9720	12 RB with RBstart=38	N/A ³	N/A ³
CA_30A-5A-29A	30	SCC1=5 SCC2=29	10	SCC1=10 SCC2=10	27710	SCC1=2600 SCC2=9720	12 RB with RBstart=0	N/A ³	N/A ³
					27710	SCC1=2600 SCC2=9720	12 RB with RBstart=19	N/A ³	N/A ³
					27710	SCC1=2600 SCC2=9720	12 RB with RBstart=38	N/A ³	N/A ³
CA_30A-5A-66A ⁴	30	SCC1=5 SCC2=66	10	SCC1=10 SCC2=10	27710	SCC1=2450 SCC2=66486	12 RB with RBstart=0	N/A ³	N/A ³
					27710	SCC1=2450 SCC2=66486	12 RB with RBstart=19	N/A ³	N/A ³
					27710	SCC1=2450 SCC2=66486	12 RB with RBstart=38	N/A ³	N/A ³

TABLE 5-32 LTE CARRIER AGGREGATION MODE (3 DOWNLINK CARRIERS, 1 UPLINK CARRIER) TRP MEASUREMENTS TABLE FOR THE PRIMARY MECHANICAL MODE¹

Carrier Aggregation Combination	Primary Component Carrier (PCC) Band	Secondary Component Carriers (SCC1/SCC2) Bands	PCC BW (MHz)	SCC BWs (MHz)	PCC UL Channel	SCC DL Channels	PCC UL RB Allocation	PCC DL RB Allocation	SCC DL RB Allocations
CA_30A-12A-66A ⁴	30	SCC1=12 SCC2=66	10	SCC1=5 SCC2=10	27710	SCC1=5035 SCC2=66486	12 RB with RBstart=0	N/A ³	N/A ³
					27710	SCC1=5035 SCC2=66486	12 RB with RBstart=19	N/A ³	N/A ³
					27710	SCC1=5035 SCC2=66486	12 RB with RBstart=38	N/A ³	N/A ³
CA_30A-29A-66A ⁴	30	SCC1=29 SCC2=66	10	SCC1=10 SCC2=10	27710	SCC1=9720 SCC2=66486	12 RB with RBstart=0	N/A ³	N/A ³
					27710	SCC1=9720 SCC2=66486	12 RB with RBstart=19	N/A ³	N/A ³
					27710	SCC1=9720 SCC2=66486	12 RB with RBstart=38	N/A ³	N/A ³
CA_30A-66C ^{4,5}	30	SCC1=66 SCC2=66	10	SCC1=10 SCC2=20	27710	SCC1=67086 SCC2=67230	12 RB with RBstart=0	N/A ³	N/A ³
					27710	SCC1=67086 SCC2=67230	12 RB with RBstart=19	N/A ³	N/A ³
					27710	SCC1=67086 SCC2=67230	12 RB with RBstart=38	N/A ³	N/A ³
CA_30A-66A-66A ⁴	30	SCC1=66 SCC2=66	10	SCC1=10 SCC2=10	27710	SCC1=66486 SCC2=67286	12 RB with RBstart=0	N/A ³	N/A ³
					27710	SCC1=66486 SCC2=67286	12 RB with RBstart=19	N/A ³	N/A ³
					27710	SCC1=66486 SCC2=67286	12 RB with RBstart=38	N/A ³	N/A ³
CA_41D	41	SCC1=41 SCC2=41	20	SCC1=20 SCC2=20	39750	SCC1=39948 SCC2=40146	18 RB with RBstart=0	N/A ³	N/A ³
					40620	SCC1=40422 SCC2=40818	18 RB with RBstart=41	N/A ³	N/A ³
					41490	SCC1=41292 SCC2=41094	18 RB with RBstart=82	N/A ³	N/A ³
CA_48A-2A-5A	48	SCC1=2 SCC2=5	10	SCC1=10 SCC2=10	55290	SCC1=1150 SCC2=2450	12 RB with RBstart=0	N/A ³	N/A ³
					55990	SCC1=1150 SCC2=2450	12 RB with RBstart=19	N/A ³	N/A ³
					56690	SCC1=1150 SCC2=2450	12 RB with RBstart=38	N/A ³	N/A ³
CA_48A-2A-13A	48	SCC1=2 SCC2=13	10	SCC1=10 SCC2=10	55290	SCC1=1150 SCC2=5230	12 RB with RBstart=0	N/A ³	N/A ³
					55990	SCC1=1150 SCC2=5230	12 RB with RBstart=19	N/A ³	N/A ³
					56690	SCC1=1150 SCC2=5230	12 RB with RBstart=38	N/A ³	N/A ³

TABLE 5-32 LTE CARRIER AGGREGATION MODE (3 DOWNLINK CARRIERS, 1 UPLINK CARRIER) TRP MEASUREMENTS TABLE FOR THE PRIMARY MECHANICAL MODE¹

Carrier Aggregation Combination	Primary Component Carrier (PCC) Band	Secondary Component Carriers (SCC1/ SCC2) Bands	PCC BW (MHz)	SCC BWs (MHz)	PCC UL Channel	SCC DL Channels	PCC UL RB Allocation	PCC DL RB Allocation	SCC DL RB Allocations
CA_48A-2A-66A	48	SCC1=2 SCC2=66	10	SCC1=10 SCC2=10	55290	SCC1=650 SCC2=67286	12 RB with RBstart=0	N/A ³	N/A ³
					55990	SCC1=650 SCC2=67286	12 RB with RBstart=19	N/A ³	N/A ³
					56690	SCC1=650 SCC2=67286	12 RB with RBstart=38	N/A ³	N/A ³
CA_48A-5A-66A	48	SCC1=5 SCC2=66	10	SCC1=10 SCC2=10	55290	SCC1=2450 SCC2=67286	12 RB with RBstart=0	N/A ³	N/A ³
					55990	SCC1=2450 SCC2=67286	12 RB with RBstart=19	N/A ³	N/A ³
					56690	SCC1=2450 SCC2=67286	12 RB with RBstart=38	N/A ³	N/A ³
CA_48A-13A-66A	48	SCC1=13 SCC2=66	10	SCC1=10 SCC2=10	55290	SCC1=5230 SCC2=67286	12 RB with RBstart=0	N/A ³	N/A ³
					55990	SCC1=5230 SCC2=67286	12 RB with RBstart=19	N/A ³	N/A ³
					56690	SCC1=5230 SCC2=67286	12 RB with RBstart=38	N/A ³	N/A ³
CA_66A-2A-2A ⁴	66	SCC1=2 SCC2=2	10	SCC1=10 SCC2=10	132022	SCC1=650 SCC2=1150	12 RB with RBstart=0	N/A ³	N/A ³
					132322	SCC1=650 SCC2=1150	12 RB with RBstart=19	N/A ³	N/A ³
					132622	SCC1=650 SCC2=1150	12 RB with RBstart=38	N/A ³	N/A ³
CA_66A-2A-5A ⁴	66	SCC1=2 SCC2=5	10	SCC1=10 SCC2=10	132022	SCC1=650 SCC2=2450	12 RB with RBstart=0	N/A ³	N/A ³
					132322	SCC1=650 SCC2=2450	12 RB with RBstart=19	N/A ³	N/A ³
					132622	SCC1=650 SCC2=2450	12 RB with RBstart=38	N/A ³	N/A ³
CA_66A-2A-12A ⁴	66	SCC1=2 SCC2=12	10	SCC1=10 SCC2=5	132022	SCC1=650 SCC2=5035	12 RB with RBstart=0	N/A ³	N/A ³
					132322	SCC1=650 SCC2=5035	12 RB with RBstart=19	N/A ³	N/A ³
					132622	SCC1=650 SCC2=5035	12 RB with RBstart=38	N/A ³	N/A ³
CA_66A-2A-13A ⁴	66	SCC1=2 SCC2=13	10	SCC1=10 SCC2=10	132022	SCC1=650 SCC2=5230	12 RB with RBstart=0	N/A ³	N/A ³
					132322	SCC1=650 SCC2=5230	12 RB with RBstart=19	N/A ³	N/A ³
					132622	SCC1=650 SCC2=5230	12 RB with RBstart=38	N/A ³	N/A ³

TABLE 5-32 LTE CARRIER AGGREGATION MODE (3 DOWNLINK CARRIERS, 1 UPLINK CARRIER) TRP MEASUREMENTS TABLE FOR THE PRIMARY MECHANICAL MODE¹

Carrier Aggregation Combination	Primary Component Carrier (PCC) Band	Secondary Component Carriers (SCC1/SCC2) Bands	PCC BW (MHz)	SCC BWs (MHz)	PCC UL Channel	SCC DL Channels	PCC UL RB Allocation	PCC DL RB Allocation	SCC DL RB Allocations
CA_66A-2A-48A ²	66	SCC1=2 SCC2=48	10	SCC1=10 SCC2=10	132022	SCC1=650 SCC2=56690	12 RB with RBstart=0	N/A ³	N/A ³
					132322	SCC1=650 SCC2=56690	12 RB with RBstart=19	N/A ³	N/A ³
					132622	SCC1=650 SCC2=56690	12 RB with RBstart=38	N/A ³	N/A ³
CA_66C-2A ^{4,5}	66	SCC1=66 SCC2=2	10	SCC1=20 SCC2=10	132022	SCC1=66630 SCC2=650	12 RB with RBstart=0	N/A ³	N/A ³
					132322	SCC1=66930 SCC2=650	12 RB with RBstart=19	N/A ³	N/A ³
					132622	SCC1=67230 SCC2=650	12 RB with RBstart=38	N/A ³	N/A ³
CA_66A-2A-66A ⁴	66	SCC1=2 SCC2=66	10	SCC1=10 SCC2=10	132022	SCC1=650 SCC2=67286	12 RB with RBstart=0	N/A ³	N/A ³
					132322	SCC1=650 SCC2=67286	12 RB with RBstart=19	N/A ³	N/A ³
					132622	SCC1=650 SCC2=66486	12 RB with RBstart=38	N/A ³	N/A ³
CA_66A-5A-5A ⁴	66	SCC1=5 SCC2=5	10	SCC1=5 SCC2=5	132022	SCC1=2425 SCC2=2625	12 RB with RBstart=0	N/A ³	N/A ³
					132322	SCC1=2425 SCC2=2625	12 RB with RBstart=19	N/A ³	N/A ³
					132622	SCC1=2425 SCC2=2625	12 RB with RBstart=38	N/A ³	N/A ³
CA_66A-5A-30A ⁴	66	SCC1=5 SCC2=30	10	SCC1=10 SCC2=10	132022	SCC1=2450 SCC2=9820	12 RB with RBstart=0	N/A ³	N/A ³
					132322	SCC1=2450 SCC2=9820	12 RB with RBstart=19	N/A ³	N/A ³
					132622	SCC1=2450 SCC2=9820	12 RB with RBstart=38	N/A ³	N/A ³
CA_66A-5A-48A ²	66	SCC1=5 SCC2=48	10	SCC1=10 SCC2=10	132022	SCC1=2450 SCC2=56690	12 RB with RBstart=0	N/A ³	N/A ³
					132322	SCC1=2450 SCC2=56690	12 RB with RBstart=19	N/A ³	N/A ³
					132622	SCC1=2450 SCC2=56690	12 RB with RBstart=38	N/A ³	N/A ³
CA_66C-5A ^{4,5}	66	SCC1=66 SCC2=5	10	SCC1=20 SCC2=10	132022	SCC1=66630 SCC2=2450	12 RB with RBstart=0	N/A ³	N/A ³
					132322	SCC1=66930 SCC2=2450	12 RB with RBstart=19	N/A ³	N/A ³
					132622	SCC1=67230 SCC2=2450	12 RB with RBstart=38	N/A ³	N/A ³

TABLE 5-32 LTE CARRIER AGGREGATION MODE (3 DOWNLINK CARRIERS, 1 UPLINK CARRIER) TRP MEASUREMENTS TABLE FOR THE PRIMARY MECHANICAL MODE¹

Carrier Aggregation Combination	Primary Component Carrier (PCC) Band	Secondary Component Carriers (SCC1/SCC2) Bands	PCC BW (MHz)	SCC BWs (MHz)	PCC UL Channel	SCC DL Channels	PCC UL RB Allocation	PCC DL RB Allocation	SCC DL RB Allocations
CA_66A-5A-66A ⁴	66	SCC1=5 SCC2=66	10	SCC1=10 SCC2=10	132022	SCC1=2450 SCC2=67286	12 RB with RBstart=0	N/A ³	N/A ³
					132322	SCC1=2450 SCC2=67286	12 RB with RBstart=19	N/A ³	N/A ³
					132622	SCC1=2450 SCC2=66486	12 RB with RBstart=38	N/A ³	N/A ³
CA_66A-12A-29A ⁴	66	SCC1=12 SCC2=29	10	SCC1=5 SCC2=10	132022	SCC1=5035 SCC2=9720	12 RB with RBstart=0	N/A ³	N/A ³
					132322	SCC1=5035 SCC2=9720	12 RB with RBstart=19	N/A ³	N/A ³
					132622	SCC1=5035 SCC2=9720	12 RB with RBstart=38	N/A ³	N/A ³
CA_66A-12A-30A ⁴	66	SCC1=12 SCC2=30	10	SCC1=5 SCC2=10	132022	SCC1=5035 SCC2=9820	12 RB with RBstart=0	N/A ³	N/A ³
					132322	SCC1=5035 SCC2=9820	12 RB with RBstart=19	N/A ³	N/A ³
					132622	SCC1=5035 SCC2=9820	12 RB with RBstart=38	N/A ³	N/A ³
CA_66C-12A ^{4,5}	66	SCC1=66 SCC2=12	10	SCC1=20 SCC2=5	132022	SCC1=66630 SCC2=5035	12 RB with RBstart=0	N/A ³	N/A ³
					132322	SCC1=66930 SCC2=5035	12 RB with RBstart=19	N/A ³	N/A ³
					132622	SCC1=67230 SCC2=5035	12 RB with RBstart=38	N/A ³	N/A ³
CA_66A-12A-66A ⁴	66	SCC1=12 SCC2=66	10	SCC1=5 SCC2=10	132022	SCC1=5035 SCC2=67286	12 RB with RBstart=0	N/A ³	N/A ³
					132322	SCC1=5035 SCC2=67286	12 RB with RBstart=19	N/A ³	N/A ³
					132622	SCC1=5035 SCC2=66486	12 RB with RBstart=38	N/A ³	N/A ³
CA_66C-13A ^{4,5}	66	SCC1=66 SCC2=13	10	SCC1=20 SCC2=10	132022	SCC1=66630 SCC2=5230	12 RB with RBstart=0	N/A ³	N/A ³
					132322	SCC1=66930 SCC2=5230	12 RB with RBstart=19	N/A ³	N/A ³
					132622	SCC1=67230 SCC2=5230	12 RB with RBstart=38	N/A ³	N/A ³
CA_66A-13A-48A ²	66	SCC1=13 SCC2=48	10	SCC1=10 SCC2=10	132022	SCC1=5230 SCC2=56690	12 RB with RBstart=0	N/A ³	N/A ³
					132322	SCC1=5230 SCC2=56690	12 RB with RBstart=19	N/A ³	N/A ³
					132622	SCC1=5230 SCC2=56690	12 RB with RBstart=38	N/A ³	N/A ³

TABLE 5-32 LTE CARRIER AGGREGATION MODE (3 DOWNLINK CARRIERS, 1 UPLINK CARRIER) TRP MEASUREMENTS TABLE FOR THE PRIMARY MECHANICAL MODE¹

Carrier Aggregation Combination	Primary Component Carrier (PCC) Band	Secondary Component Carriers (SCC1/SCC2) Bands	PCC BW (MHz)	SCC BWs (MHz)	PCC UL Channel	SCC DL Channels	PCC UL RB Allocation	PCC DL RB Allocation	SCC DL RB Allocations
CA_66A-13A-66A ⁴	66	SCC1=13 SCC2=66	10	SCC1=10 SCC2=10	132022	SCC1=5230 SCC2=67286	12 RB with RBstart=0	N/A ³	N/A ³
					132322	SCC1=5230 SCC2=67286	12 RB with RBstart=19	N/A ³	N/A ³
					132622	SCC1=5230 SCC2=66486	12 RB with RBstart=38	N/A ³	N/A ³
CA_66A-29A-30A ⁴	66	SCC1=29 SCC2=30	10	SCC1=10 SCC2=10	132022	SCC1=9720 SCC2=9820	12 RB with RBstart=0	N/A ³	N/A ³
					132322	SCC1=9720 SCC2=9820	12 RB with RBstart=19	N/A ³	N/A ³
					132622	SCC1=9720 SCC2=9820	12 RB with RBstart=38	N/A ³	N/A ³
CA_66C-29A ^{4,5}	66	SCC1=66 SCC2=29	10	SCC1=20 SCC2=10	132022	SCC1=66630 SCC2=9720	12 RB with RBstart=0	N/A ³	N/A ³
					132322	SCC1=66930 SCC2=9720	12 RB with RBstart=19	N/A ³	N/A ³
					132622	SCC1=67230 SCC2=9720	12 RB with RBstart=38	N/A ³	N/A ³
CA_66A-29A-66A ⁴	66	SCC1=29 SCC2=66	10	SCC1=10 SCC2=10	132022	SCC1=9720 SCC2=67286	12 RB with RBstart=0	N/A ³	N/A ³
					132322	SCC1=9720 SCC2=67286	12 RB with RBstart=19	N/A ³	N/A ³
					132622	SCC1=9720 SCC2=66486	12 RB with RBstart=38	N/A ³	N/A ³
CA_66C-30A ^{4,5}	66	SCC1=66 SCC2=30	10	SCC1=20 SCC2=10	132022	SCC1=66630 SCC2=9820	12 RB with RBstart=0	N/A ³	N/A ³
					132322	SCC1=66930 SCC2=9820	12 RB with RBstart=19	N/A ³	N/A ³
					132622	SCC1=67230 SCC2=9820	12 RB with RBstart=38	N/A ³	N/A ³
CA_66A-30A-66A ⁴	66	SCC1=30 SCC2=66	10	SCC1=10 SCC2=10	132022	SCC1=9820 SCC2=67286	12 RB with RBstart=0	N/A ³	N/A ³
					132322	SCC1=9820 SCC2=67286	12 RB with RBstart=19	N/A ³	N/A ³
					132622	SCC1=9820 SCC2=66486	12 RB with RBstart=38	N/A ³	N/A ³
CA_66D	66	SCC1=66 SCC2=66	10	SCC1=20 SCC2=20	132022	SCC1=66630 SCC2=66828	12 RB with RBstart=0	N/A ³	N/A ³
					132322	SCC1=66642 SCC2=66930	12 RB with RBstart=19	N/A ³	N/A ³
					132622	SCC1=66942 SCC2=67230	12 RB with RBstart=38	N/A ³	N/A ³

TABLE 5-32 LTE CARRIER AGGREGATION MODE (3 DOWNLINK CARRIERS, 1 UPLINK CARRIER) TRP MEASUREMENTS TABLE FOR THE PRIMARY MECHANICAL MODE¹

Carrier Aggregation Combination	Primary Component Carrier (PCC) Band	Secondary Component Carriers (SCC1/SCC2) Bands	PCC BW (MHz)	SCC BWs (MHz)	PCC UL Channel	SCC DL Channels	PCC UL RB Allocation	PCC DL RB Allocation	SCC DL RB Allocations
CA_66C-66A ⁵	66	SCC1=66 SCC2=66	10	SCC1=20 SCC2=10	132022	SCC1=66630 SCC2=67286	12 RB with RBstart=0	N/A ³	N/A ³
					132322	SCC1=66930 SCC2=67286	12 RB with RBstart=19	N/A ³	N/A ³
					132622	SCC1=67230 SCC2=66486	12 RB with RBstart=38	N/A ³	N/A ³
CA_66A-66C ⁵	66	SCC1=66 SCC2=66	10	SCC1=10 SCC2=20	132022	SCC1=67086 SCC2=67230	12 RB with RBstart=0	N/A ³	N/A ³
					132322	SCC1=67086 SCC2=67230	12 RB with RBstart=19	N/A ³	N/A ³
					132622	SCC1=66486 SCC2=66630	12 RB with RBstart=38	N/A ³	N/A ³

Note 1: Primary Mechanical Mode refers to device configured in preferred mode per manufacturer instructions (typically means antenna extended, fold or portrait slide open, but depends on form factor).

Note 2: This combination creates harmonic, intermodulation, or self-desense interference to one or both of the SCCs. The power level of the SCCs shall be adjusted as needed to maintain the LTE carrier aggregation connection and error free operation on the SCCs.

Note 3: As per 3GPP TS 36.521-1, Section 6.2.2A (UE Maximum Output Power for CA).

Note 4: If the device supports both CA_4A-xA-yA and CA_66A-xA-yA (where x and y are the band numbers of the SCC's), then testing is only required in CA_66A-xA-yA. Similarly, if the device supports both CA_xA-4A-yA and CA_xA-66A-yA (where x is the band number of the PCC and y is the band number of the other SCC), then testing is only required in CA_xA-66A-yA; and if the device supports both CA_xA-yA-4A and CA_xA-yA-66A (where x is the band number of the PCC and y is the band number of the other SCC), then testing is only required in CA_xA-yA-66A.

Note 5: Since all Band 66-capable devices are required to support both CA_66B and CA_66C per 3GPP TS 36.101, testing of xA-66B and 66B-xA combinations is not required.

Hand phantom only and/or free-space testing shall be conducted based on device type, as specified in [Appendix O](#). Refer to [Appendix C](#) for hand testing requirements. Perform each test on all specified frequencies and RB allocations with the EUT antenna extended and retracted, as applicable.

Note: Head-adjacent testing is not required for LTE CA.

Note: EUTs incapable of supporting the aggregated channel BW associated with the CA modes specified in [Table 5-32](#) do not need to be tested.

5.13.2 Criteria

Results shall be reported as specified in [Appendix B](#) using the figures of merit given in [Appendix B.3](#). [Appendix B.1](#) contains the pass/fail OTA tables for 3 downlink LTE carrier aggregation. Reports shall include results for free-space and hand only configurations (if applicable) across all channels and RB

allocations measured with the EUT in primary mechanical mode, and (if applicable) in secondary mechanical modes as reference information.

TABLE 5-33 LTE CARRIER AGGREGATION MODE (3 DOWNLINK CARRIERS, 1 UPLINK CARRIER) TRP CRITERIA TABLE FOR THE PRIMARY MECHANICAL MODE¹

Carrier Aggregation Combination	Device Held to Head for Voice	Device Width (mm) ²	Free Space	HL and HR
CA_2A-2A-4A	Yes ³	≤72	TBD	TBD
	Yes ³	>72	TBD	TBD
	No ⁴	All	TBD	N/A
CA_2A-2A-5A	Yes ³	≤72	TBD	TBD
	Yes ³	>72	TBD	TBD
	No ⁴	All	TBD	N/A
CA_2A-2A-12A	Yes ³	≤72	TBD	TBD
	Yes ³	>72	TBD	TBD
	No ⁴	All	TBD	N/A
CA_2A-2A-13A	Yes ³	≤72	TBD	TBD
	Yes ³	>72	TBD	TBD
	No ⁴	All	TBD	N/A
CA_2A-2A-66A	Yes ³	≤72	TBD	TBD
	Yes ³	>72	TBD	TBD
	No ⁴	All	TBD	N/A
CA_2A-4A-4A	Yes ³	≤72	TBD	TBD
	Yes ³	>72	TBD	TBD
	No ⁴	All	TBD	N/A
CA_2A-4A-5A	Yes ³	≤72	TBD	TBD
	Yes ³	>72	TBD	TBD
	No ⁴	All	TBD	N/A
CA_2A-4A-12A	Yes ³	≤72	TBD	TBD
	Yes ³	>72	TBD	TBD
	No ⁴	All	TBD	N/A
CA_2A-4A-13A	Yes ³	≤72	TBD	TBD
	Yes ³	>72	TBD	TBD
	No ⁴	All	TBD	N/A
CA_2A-5A-30A	Yes ³	≤72	TBD	TBD
	Yes ³	>72	TBD	TBD
	No ⁴	All	TBD	N/A
CA_2A-5A-48A	Yes ³	≤72	TBD	TBD
	Yes ³	>72	TBD	TBD
	No ⁴	All	TBD	N/A

TABLE 5-33 LTE CARRIER AGGREGATION MODE (3 DOWNLINK CARRIERS, 1 UPLINK CARRIER) TRP CRITERIA TABLE FOR THE PRIMARY MECHANICAL MODE¹

Carrier Aggregation Combination	Device Held to Head for Voice	Device Width (mm) ²	Free Space	HL and HR
CA_2A-5A-66A	Yes ³	≤72	TBD	TBD
	Yes ³	>72	TBD	TBD
	No ⁴	All	TBD	N/A
CA_2A-12A-30A	Yes ³	≤72	TBD	TBD
	Yes ³	>72	TBD	TBD
	No ⁴	All	TBD	N/A
CA_2A-12A-66A	Yes ³	≤72	TBD	TBD
	Yes ³	>72	TBD	TBD
	No ⁴	All	TBD	N/A
CA_2A-13A-48A	Yes ³	≤72	TBD	TBD
	Yes ³	>72	TBD	TBD
	No ⁴	All	TBD	N/A
CA_2A-13A-66A	Yes ³	≤72	TBD	TBD
	Yes ³	>72	TBD	TBD
	No ⁴	All	TBD	N/A
CA_2A-29A-30A	Yes ³	≤72	TBD	TBD
	Yes ³	>72	TBD	TBD
	No ⁴	All	TBD	N/A
CA_2A-48A-66A	Yes ³	≤72	TBD	TBD
	Yes ³	>72	TBD	TBD
	No ⁴	All	TBD	N/A
CA_2A-66C	Yes ³	≤72	TBD	TBD
	Yes ³	>72	TBD	TBD
	No ⁴	All	TBD	N/A
CA_2A-66A-66A	Yes ³	≤72	TBD	TBD
	Yes ³	>72	TBD	TBD
	No ⁴	All	TBD	N/A
CA_4A-2A-4A	Yes ³	≤72	TBD	TBD
	Yes ³	>72	TBD	TBD
	No ⁴	All	TBD	N/A
CA_4A-2A-5A	Yes ³	≤72	TBD	TBD
	Yes ³	>72	TBD	TBD
	No ⁴	All	TBD	N/A

TABLE 5-33 LTE CARRIER AGGREGATION MODE (3 DOWNLINK CARRIERS, 1 UPLINK CARRIER) TRP CRITERIA TABLE FOR THE PRIMARY MECHANICAL MODE¹

Carrier Aggregation Combination	Device Held to Head for Voice	Device Width (mm) ²	Free Space	HL and HR
CA_4A-2A-12A	Yes ³	≤72	TBD	TBD
	Yes ³	>72	TBD	TBD
	No ⁴	All	TBD	N/A
CA_4A-2A-13A	Yes ³	≤72	TBD	TBD
	Yes ³	>72	TBD	TBD
	No ⁴	All	TBD	N/A
CA_4A-4A-5A	Yes ³	≤72	TBD	TBD
	Yes ³	>72	TBD	TBD
	No ⁴	All	TBD	N/A
CA_4A-4A-12A	Yes ³	≤72	TBD	TBD
	Yes ³	>72	TBD	TBD
	No ⁴	All	TBD	N/A
CA_4A-4A-13A	Yes ³	≤72	TBD	TBD
	Yes ³	>72	TBD	TBD
	No ⁴	All	TBD	N/A
CA_4A-5A-30A	Yes ³	≤72	TBD	TBD
	Yes ³	>72	TBD	TBD
	No ⁴	All	TBD	N/A
CA_4A-12A-30A	Yes ³	≤72	TBD	TBD
	Yes ³	>72	TBD	TBD
	No ⁴	All	TBD	N/A
CA_4A-29A-30A	Yes ³	≤72	TBD	TBD
	Yes ³	>72	TBD	TBD
	No ⁴	All	TBD	N/A
CA_5A-2A-2A	Yes ³	≤72	TBD	TBD
	Yes ³	>72	TBD	TBD
	No ⁴	All	TBD	N/A
CA_5A-2A-4A	Yes ³	≤72	TBD	TBD
	Yes ³	>72	TBD	TBD
	No ⁴	All	TBD	N/A
CA_5A-2A-30A	Yes ³	≤72	TBD	TBD
	Yes ³	>72	TBD	TBD
	No ⁴	All	TBD	N/A

TABLE 5-33 LTE CARRIER AGGREGATION MODE (3 DOWNLINK CARRIERS, 1 UPLINK CARRIER) TRP CRITERIA TABLE FOR THE PRIMARY MECHANICAL MODE¹

Carrier Aggregation Combination	Device Held to Head for Voice	Device Width (mm) ²	Free Space	HL and HR
CA_5A-2A-48A	Yes ³	≤72	TBD	TBD
	Yes ³	>72	TBD	TBD
	No ⁴	All	TBD	N/A
CA_5A-2A-66A	Yes ³	≤72	TBD	TBD
	Yes ³	>72	TBD	TBD
	No ⁴	All	TBD	N/A
CA_5A-4A-4A	Yes ³	≤72	TBD	TBD
	Yes ³	>72	TBD	TBD
	No ⁴	All	TBD	N/A
CA_5A-4A-30A	Yes ³	≤72	TBD	TBD
	Yes ³	>72	TBD	TBD
	No ⁴	All	TBD	N/A
CA_5A-5A-66A	Yes ³	≤72	TBD	TBD
	Yes ³	>72	TBD	TBD
	No ⁴	All	TBD	N/A
CA_5A-29A-30A	Yes ³	≤72	TBD	TBD
	Yes ³	>72	TBD	TBD
	No ⁴	All	TBD	N/A
CA_5A-30A-66A	Yes ³	≤72	TBD	TBD
	Yes ³	>72	TBD	TBD
	No ⁴	All	TBD	N/A
CA_5A-48A-66A	Yes ³	≤72	TBD	TBD
	Yes ³	>72	TBD	TBD
	No ⁴	All	TBD	N/A
CA_5A-66C	Yes ³	≤72	TBD	TBD
	Yes ³	>72	TBD	TBD
	No ⁴	All	TBD	N/A
CA_5A-66A-66A	Yes ³	≤72	TBD	TBD
	Yes ³	>72	TBD	TBD
	No ⁴	All	TBD	N/A
CA_12A-2A-2A	Yes ³	≤72	TBD	TBD
	Yes ³	>72	TBD	TBD
	No ⁴	All	TBD	N/A

TABLE 5-33 LTE CARRIER AGGREGATION MODE (3 DOWNLINK CARRIERS, 1 UPLINK CARRIER) TRP CRITERIA TABLE FOR THE PRIMARY MECHANICAL MODE¹

Carrier Aggregation Combination	Device Held to Head for Voice	Device Width (mm) ²	Free Space	HL and HR
CA_12A-2A-4A	Yes ³	≤72	TBD	TBD
	Yes ³	>72	TBD	TBD
	No ⁴	All	TBD	N/A
CA_12A-2A-30A	Yes ³	≤72	TBD	TBD
	Yes ³	>72	TBD	TBD
	No ⁴	All	TBD	N/A
CA_12A-2A-66A	Yes ³	≤72	TBD	TBD
	Yes ³	>72	TBD	TBD
	No ⁴	All	TBD	N/A
CA_12A-4A-4A	Yes ³	≤72	TBD	TBD
	Yes ³	>72	TBD	TBD
	No ⁴	All	TBD	N/A
CA_12A-4A-30A	Yes ³	≤72	TBD	TBD
	Yes ³	>72	TBD	TBD
	No ⁴	All	TBD	N/A
CA_12A-29A-66A	Yes ³	≤72	TBD	TBD
	Yes ³	>72	TBD	TBD
	No ⁴	All	TBD	N/A
CA_12A-30A-66A	Yes ³	≤72	TBD	TBD
	Yes ³	>72	TBD	TBD
	No ⁴	All	TBD	N/A
CA_12A-66C	Yes ³	≤72	TBD	TBD
	Yes ³	>72	TBD	TBD
	No ⁴	All	TBD	N/A
CA_12A-66A-66A	Yes ³	≤72	TBD	TBD
	Yes ³	>72	TBD	TBD
	No ⁴	All	TBD	N/A
CA_13A-2A-2A	Yes ³	≤72	TBD	TBD
	Yes ³	>72	TBD	TBD
	No ⁴	All	TBD	N/A
CA_13A-2A-2A	Yes ³	≤72	TBD	TBD
	Yes ³	>72	TBD	TBD
	No ⁴	All	TBD	N/A

TABLE 5-33 LTE CARRIER AGGREGATION MODE (3 DOWNLINK CARRIERS, 1 UPLINK CARRIER) TRP CRITERIA TABLE FOR THE PRIMARY MECHANICAL MODE¹

Carrier Aggregation Combination	Device Held to Head for Voice	Device Width (mm) ²	Free Space	HL and HR
CA_13A-2A-4A	Yes ³	≤72	TBD	TBD
	Yes ³	>72	TBD	TBD
	No ⁴	All	TBD	N/A
CA_13A-2A-48A	Yes ³	≤72	TBD	TBD
	Yes ³	>72	TBD	TBD
	No ⁴	All	TBD	N/A
CA_13A-2A-66A	Yes ³	≤72	TBD	TBD
	Yes ³	>72	TBD	TBD
	No ⁴	All	TBD	N/A
CA_13A-4A-4A	Yes ³	≤72	TBD	TBD
	Yes ³	>72	TBD	TBD
	No ⁴	All	TBD	N/A
CA_13A-48A-66A	Yes ³	≤72	TBD	TBD
	Yes ³	>72	TBD	TBD
	No ⁴	All	TBD	N/A
CA_13A-66C	Yes ³	≤72	TBD	TBD
	Yes ³	>72	TBD	TBD
	No ⁴	All	TBD	N/A
CA_13A-66A-66A	Yes ³	≤72	TBD	TBD
	Yes ³	>72	TBD	TBD
	No ⁴	All	TBD	N/A
CA_25A-41C	Yes ³	≤72	TBD	TBD
	Yes ³	>72	TBD	TBD
	No ⁴	All	TBD	N/A
CA_30A-2A-5A	Yes ³	≤72	TBD	TBD
	Yes ³	>72	TBD	TBD
	No ⁴	All	TBD	N/A
CA_30A-2A-12A	Yes ³	≤72	TBD	TBD
	Yes ³	>72	TBD	TBD
	No ⁴	All	TBD	N/A
CA_30A-2A-29A	Yes ³	≤72	TBD	TBD
	Yes ³	>72	TBD	TBD
	No ⁴	All	TBD	N/A

TABLE 5-33 LTE CARRIER AGGREGATION MODE (3 DOWNLINK CARRIERS, 1 UPLINK CARRIER) TRP CRITERIA TABLE FOR THE PRIMARY MECHANICAL MODE¹

Carrier Aggregation Combination	Device Held to Head for Voice	Device Width (mm) ²	Free Space	HL and HR
CA_30A-4A-5A	Yes ³	≤72	TBD	TBD
	Yes ³	>72	TBD	TBD
	No ⁴	All	TBD	N/A
CA_30A-4A-12A	Yes ³	≤72	TBD	TBD
	Yes ³	>72	TBD	TBD
	No ⁴	All	TBD	N/A
CA_30A-4A-29A	Yes ³	≤72	TBD	TBD
	Yes ³	>72	TBD	TBD
	No ⁴	All	TBD	N/A
CA_30A-5A-29A	Yes ³	≤72	TBD	TBD
	Yes ³	>72	TBD	TBD
	No ⁴	All	TBD	N/A
CA_30A-5A-66A	Yes ³	≤72	TBD	TBD
	Yes ³	>72	TBD	TBD
	No ⁴	All	TBD	N/A
CA_30A-12A-66A	Yes ³	≤72	TBD	TBD
	Yes ³	>72	TBD	TBD
	No ⁴	All	TBD	N/A
CA_30A-29A-66A	Yes ³	≤72	TBD	TBD
	Yes ³	>72	TBD	TBD
	No ⁴	All	TBD	N/A
CA_30A-66C	Yes ³	≤72	TBD	TBD
	Yes ³	>72	TBD	TBD
	No ⁴	All	TBD	N/A
CA_30A-66A-66A	Yes ³	≤72	TBD	TBD
	Yes ³	>72	TBD	TBD
	No ⁴	All	TBD	N/A
CA_41D	Yes ³	≤72	TBD	TBD
	Yes ³	>72	TBD	TBD
	No ⁴	All	TBD	N/A
CA_48A-2A-5A	Yes ³	≤72	TBD	TBD
	Yes ³	>72	TBD	TBD
	No ⁴	All	TBD	N/A

TABLE 5-33 LTE CARRIER AGGREGATION MODE (3 DOWNLINK CARRIERS, 1 UPLINK CARRIER) TRP CRITERIA TABLE FOR THE PRIMARY MECHANICAL MODE¹

Carrier Aggregation Combination	Device Held to Head for Voice	Device Width (mm) ²	Free Space	HL and HR
CA_48A-2A-13A	Yes ³	≤72	TBD	TBD
	Yes ³	>72	TBD	TBD
	No ⁴	All	TBD	N/A
CA_48A-2A-66A	Yes ³	≤72	TBD	TBD
	Yes ³	>72	TBD	TBD
	No ⁴	All	TBD	N/A
CA_48A-5A-66A	Yes ³	≤72	TBD	TBD
	Yes ³	>72	TBD	TBD
	No ⁴	All	TBD	N/A
CA_48A-13A-66A	Yes ³	≤72	TBD	TBD
	Yes ³	>72	TBD	TBD
	No ⁴	All	TBD	N/A
CA_66A-2A-2A	Yes ³	≤72	TBD	TBD
	Yes ³	>72	TBD	TBD
	No ⁴	All	TBD	N/A
CA_66A-2A-5A	Yes ³	≤72	TBD	TBD
	Yes ³	>72	TBD	TBD
	No ⁴	All	TBD	N/A
CA_66A-2A-12A	Yes ³	≤72	TBD	TBD
	Yes ³	>72	TBD	TBD
	No ⁴	All	TBD	N/A
CA_66A-2A-13A	Yes ³	≤72	TBD	TBD
	Yes ³	>72	TBD	TBD
	No ⁴	All	TBD	N/A
CA_66A-2A-48A	Yes ³	≤72	TBD	TBD
	Yes ³	>72	TBD	TBD
	No ⁴	All	TBD	N/A
CA_66C-2A	Yes ³	≤72	TBD	TBD
	Yes ³	>72	TBD	TBD
	No ⁴	All	TBD	N/A
CA_66A-2A-66A	Yes ³	≤72	TBD	TBD
	Yes ³	>72	TBD	TBD
	No ⁴	All	TBD	N/A

TABLE 5-33 LTE CARRIER AGGREGATION MODE (3 DOWNLINK CARRIERS, 1 UPLINK CARRIER) TRP CRITERIA TABLE FOR THE PRIMARY MECHANICAL MODE¹

Carrier Aggregation Combination	Device Held to Head for Voice	Device Width (mm) ²	Free Space	HL and HR
CA_66A-5A-5A	Yes ³	≤72	TBD	TBD
	Yes ³	>72	TBD	TBD
	No ⁴	All	TBD	N/A
CA_66A-5A-30A	Yes ³	≤72	TBD	TBD
	Yes ³	>72	TBD	TBD
	No ⁴	All	TBD	N/A
CA_66A-5A-48A	Yes ³	≤72	TBD	TBD
	Yes ³	>72	TBD	TBD
	No ⁴	All	TBD	N/A
CA_66C-5A	Yes ³	≤72	TBD	TBD
	Yes ³	>72	TBD	TBD
	No ⁴	All	TBD	N/A
CA_66A-5A-66A	Yes ³	≤72	TBD	TBD
	Yes ³	>72	TBD	TBD
	No ⁴	All	TBD	N/A
CA_66A-12A-29A	Yes ³	≤72	TBD	TBD
	Yes ³	>72	TBD	TBD
	No ⁴	All	TBD	N/A
CA_66A-12A-30A	Yes ³	≤72	TBD	TBD
	Yes ³	>72	TBD	TBD
	No ⁴	All	TBD	N/A
CA_66C-12A	Yes ³	≤72	TBD	TBD
	Yes ³	>72	TBD	TBD
	No ⁴	All	TBD	N/A
CA_66A-12A-66A	Yes ³	≤72	TBD	TBD
	Yes ³	>72	TBD	TBD
	No ⁴	All	TBD	N/A
CA_66A-13A-48A	Yes ³	≤72	TBD	TBD
	Yes ³	>72	TBD	TBD
	No ⁴	All	TBD	N/A
CA_66C-13A	Yes ³	≤72	TBD	TBD
	Yes ³	>72	TBD	TBD
	No ⁴	All	TBD	N/A

TABLE 5-33 LTE CARRIER AGGREGATION MODE (3 DOWNLINK CARRIERS, 1 UPLINK CARRIER) TRP CRITERIA TABLE FOR THE PRIMARY MECHANICAL MODE¹

Carrier Aggregation Combination	Device Held to Head for Voice	Device Width (mm) ²	Free Space	HL and HR
CA_66A-13A-66A	Yes ³	≤72	TBD	TBD
	Yes ³	>72	TBD	TBD
	No ⁴	All	TBD	N/A
CA_66A-29A-30A	Yes ³	≤72	TBD	TBD
	Yes ³	>72	TBD	TBD
	No ⁴	All	TBD	N/A
CA_66C-29A	Yes ³	≤72	TBD	TBD
	Yes ³	>72	TBD	TBD
	No ⁴	All	TBD	N/A
CA_66A-29A-66A	Yes ³	≤72	TBD	TBD
	Yes ³	>72	TBD	TBD
	No ⁴	All	TBD	N/A
CA_66C-30A	Yes ³	≤72	TBD	TBD
	Yes ³	>72	TBD	TBD
	No ⁴	All	TBD	N/A
CA_66A-30A-66A	Yes ³	≤72	TBD	TBD
	Yes ³	>72	TBD	TBD
	No ⁴	All	TBD	N/A
CA_66D	Yes ³	≤72	TBD	TBD
	Yes ³	>72	TBD	TBD
	No ⁴	All	TBD	N/A
CA_66C-66A	Yes ³	≤72	TBD	TBD
	Yes ³	>72	TBD	TBD
	No ⁴	All	TBD	N/A
CA_66A-66C	Yes ³	≤72	TBD	TBD
	Yes ³	>72	TBD	TBD
	No ⁴	All	TBD	N/A

Note 1: Primary Mechanical Mode refers to device configured in preferred mode per manufacturer instructions (typically means antenna extended, fold or portrait slide open, but depends on form factor).

Note 2: Differences between requirements for devices wider and narrower than 72 mm reflect observed differences in OTA performance with different hand phantoms of up to 6 dB.

Note 3: “Yes” applies if the device supports voice operation in the talking position against the head in LTE mode.

Note 4: “No” would be applicable to data-centric devices that are not held up against the head, e.g., embedded laptop solutions.

5.14 OTA Testing of Devices Containing Multiple TX Antennas

5.14.1 Devices where the Active TX Antenna Could Change during the Execution of the Test Cases

These are devices where the choice of which TX antenna is active is not a function of the use case of the device. Instead, TX antenna selection is made according to other parameters such as, but not limited to base station control, user control, Rx signal level or other means that originate external to the device. Such a device may switch from one TX antenna to another, but requires specific inputs from an external control source to do so. At this time, devices of this type must measure TRP for each TX antenna individually and the measured values shall be reported accordingly in the Test Report. Devices supporting TX switched diversity are in this device category as well.

1. The manufacturer shall provide either:
 - a. Equipment and/or software which will allow the test lab to control which TX antenna is used. Or,
 - b. Otherwise identical test devices which are pre-configured for each TX antenna selection.
2. The device manufacturer shall indicate which frequency bands and air interfaces support TX antenna switching in Table B-2.

The antenna with better TRP will be used to determine the pass/fail compliance. The better antenna between the two transmitting antennas is always identified as the primary antenna, and the weaker antenna is the secondary antenna.

5.14.2 Devices where the Active TX Antenna Does Not Switch during the Execution of the Test Cases

These are devices where the choice of which TX antenna is active is a function of the proximity to the user's hand, head or body, or nearby object and is usually determined by sensors contained within the device. Such a device will switch from one TX antenna to another based on the inputs it receives from its own self-contained sensors. The sensors may detect proximity of human tissue (hand, head or body) or may detect proximity of external objects (tables, seats, etc.). In such a device, it is required that the choice of TX antenna of the device remains the same during the TRP test. Below are listed the basic requirements and conditions for two testing mode options, autonomous and non-autonomous defined for FS, BHHL, BHHR, HR, and HL test cases.

1. Autonomous Mode
 - a. If the manufacturer chooses, the device is allowed to operate in a fully autonomous mode where it actively chooses the TX antenna depending on the test case during the TRP test.
2. Non-Autonomous Mode
 - a. The device manufacturer shall supply a "truth table" that clearly identifies which TX antenna will be used for all of the test cases (FS, BHHL, BHHR, HL, HR).
 - b. In addition, the manufacturer shall provide either:
 - i. Equipment and/or software which will allow the test lab to control which TX antenna is used for each test case, per the truth table. Or,
 - ii. Otherwise identical test devices which are pre-configured for the TX antenna selections per the truth table.
 - c. The device is allowed to change the TX antenna that it uses at different RF frequencies within the same band, or when different TX power levels are chosen, or when a different air interface is chosen, or other manufacturer declared conditions, as long as this is clearly indicated in the truth table.

5.15 LTE Category M1

5.15.1 Test Procedure

The measurement site and EUT shall be configured as specified in [Appendix A](#). The power radiated by the EUT shall be measured using a calibrated and accurate RF measuring instrument (e.g., a spectrum analyzer, or measurement receiver, or power meter).

Note: See [Appendix D](#) for power measurement considerations.

The LTE system simulator and EUT shall be configured per 3GPP TS 36.521-1, Section 6.2.2EA (UE Maximum Output Power for UE Category M1) using the default settings specified in 3GPP TS 36.521-1 and 3GPP TS 36.508 as applicable and using the uplink reference measurement channels defined in Tables A.2.2.2.1-1b and A.2.3.2.1-1b of 3GPP TS 36.521-1 and [Table 5-34](#). The test procedure in section 6.2.2EA of 3GPP TS 36.521-1 shall be used to measure the UE output power.

Tests shall be carried out for different frequency pairs (FDD, HD-FDD; UL -uplink /DL -downlink) or frequencies (TDD) and RB allocations across the bands supported by the EUT, as defined in [Table 5-34](#).

TABLE 5-34 LTE Category M1 TRP Measurements Table for the Primary Mechanical Mode¹

Band	Channel Bandwidth (MHz)	Channel	Power Class 3		Power Class 5		DL RB Allocation
			Frequency (MHz)	UL RB Allocation	Frequency (MHz)	UL RB Allocation	
2	10	18650	1851.04	4 RB with RBstart=1	1851.13	5 RB with RBstart=1	N/A ³
	10	18900	1880.36	4 RB with RBstart=25	1880.45	5 RB with RBstart=25	N/A ³
	10	19150	1908.96	4 RB with RBstart=45	1908.87	5 RB with RBstart=44	N/A ³
4	10	20000	1711.04	4 RB with RBstart=1	1711.13	5 RB with RBstart=1	N/A ³
	10	20175	1732.86	4 RB with RBstart=25	1732.95	5 RB with RBstart=25	N/A ³
	10	20350	1753.96	4 RB with RBstart=45	1753.87	5 RB with RBstart=44	N/A ³
5 ²	10	20450	825.04	4 RB with RBstart=1	825.13	5 RB with RBstart=1	N/A ³
	10	20525	836.86	4 RB with RBstart=25	836.95	5 RB with RBstart=25	N/A ³
	10	20600	847.96	4 RB with RBstart=45	847.87	5 RB with RBstart=44	N/A ³
7	20	20850	2501.9	6 RB with RBstart=2	2501.9	6 RB with RBstart=2	N/A ³
	20	21100	2535.54	6 RB with RBstart=50	2535.54	6 RB with RBstart=50	N/A ³
	20	21350	2568.1	6 RB with RBstart=92	2568.1	6 RB with RBstart=92	N/A ³
12	5	23035	699.34	1 RB with RBstart=0	699.52	3 RB with RBstart=0	N/A ³
	5	23095	707.68	1 RB with RBstart=13	707.86	3 RB with RBstart=13	N/A ³
	5	23155	715.66	1 RB with RBstart=24	715.48	3 RB with RBstart=22	N/A ³
13	10	23230	778.04	4 RB with RBstart=1	778.13	5 RB with RBstart=1	N/A ³
	10	23230	782.36	4 RB with RBstart=25	782.45	5 RB with RBstart=25	N/A ³
	10	23230	785.96	4 RB with RBstart=45	785.87	5 RB with RBstart=44	N/A ³
26 ²	5	26715	814.34	1 RB with RBstart=0	814.52	3 RB with RBstart=0	N/A ³
	5	26865	831.68	1 RB with RBstart=13	831.86	3 RB with RBstart=13	N/A ³
	5	27015	848.66	1 RB with RBstart=24	848.48	3 RB with RBstart=22	N/A ³
41	20	39750	2497.9	6 RB with RBstart=2	2497.9	6 RB with RBstart=2	N/A ³
	20	40620	2593.54	6 RB with RBstart=50	2593.54	6 RB with RBstart=50	N/A ³
	20	41490	2688.1	6 RB with RBstart=92	2688.1	6 RB with RBstart=92	N/A ³
71	10	133172	664.04	4 RB with RBstart=1	664.13	5 RB with RBstart=1	N/A ³
	10	133297	680.86	4 RB with RBstart=25	680.95	5 RB with RBstart=25	N/A ³
	10	133422	696.96	4 RB with RBstart=45	696.87	5 RB with RBstart=44	N/A ³

Note 1: Primary Mechanical Mode refers to device configured in preferred mode per manufacturer instructions (typically means antenna extended, fold or portrait slide open, but depends on form factor).

Note 2: If the device supports Band 26 and Band 5, then testing is only required to be completed in Band 26.

Note 3: As per 3GPP TS 36.521-1, Section 6.2.2EA (UE Maximum Output Power for UE Category M1).

Forearm and/or free-space testing shall be conducted based on device type, as specified in [Appendix O](#). Refer to [Appendix Q](#) for forearm testing requirements. Perform each test on all specified frequencies and RB allocations with the EUT antenna extended and retracted, as applicable.

5.15.2 Criteria

Results shall be reported as specified in [Appendix B](#) using the figures of merit given in [Appendix B.3](#). Pass/fail criteria for LTE Category M1 is for future study, and different pass/fail criteria may be developed for different device types/use cases. Reports shall include results for applicable use cases, including free-space and/or wrist-worn configurations across all channels and RB allocations measured with the EUT in primary mechanical mode, and (if applicable) in non-primary mechanical modes as reference information.

TABLE 5-35 LTE CAT-M1 MINIMUM TRP LEVEL (IN DBM) REQUIREMENTS FOR THE PRIMARY MECHANICAL MODE¹

Band	Device Worn on Wrist?	Power Class	FS	WL and WR
LTE Band 71	Yes	3	N/A	TBD
		5	N/A	TBD
	No	3	TBD	N/A
		5	TBD	N/A
LTE Band 12	Yes	3	N/A	TBD
		5	N/A	TBD
	No	3	TBD	N/A
		5	TBD	N/A
LTE Band 13	Yes	3	N/A	TBD
		5	N/A	TBD
	No	3	TBD	N/A
		5	TBD	N/A
LTE Band 26	Yes	3	N/A	TBD
		5	N/A	TBD
	No	3	TBD	N/A
		5	TBD	N/A
LTE Band 5	Yes	3	N/A	TBD
		5	N/A	TBD
	No	3	TBD	N/A
		5	TBD	N/A
LTE Band 2	Yes	3	N/A	TBD
		5	N/A	TBD
	No	3	TBD	N/A
		5	TBD	N/A
LTE Band 4	Yes	3	N/A	TBD
		5	N/A	TBD
	No	3	TBD	N/A
		5	TBD	N/A

TABLE 5-35 LTE CAT-M1 MINIMUM TRP LEVEL (IN DBM) REQUIREMENTS FOR THE PRIMARY MECHANICAL MODE¹

Band	Device Worn on Wrist?	Power Class	FS	WL and WR
LTE Band 7	Yes	3	N/A	TBD
		5	N/A	TBD
	No	3	TBD	N/A
		5	TBD	N/A
LTE Band 41	Yes	3	N/A	TBD
		5	N/A	TBD
	No	3	TBD	N/A
		5	TBD	N/A

Note 1: Primary Mechanical Mode refers to device configured in preferred mode per manufacturer instructions (typically means antenna extended, fold or portrait slide open, but depends on form factor).

5.16 LTE Category NB1 (NB-IoT)

5.16.1 Test Procedure

The measurement site and EUT shall be configured as specified in [Appendix A](#). The power radiated by the EUT shall be measured using a calibrated and accurate RF measuring instrument (e.g., a spectrum analyzer, or measurement receiver, or power meter).

Note: See [Appendix D](#) for power measurement considerations.

The LTE system simulator and EUT shall be configured per 3GPP TS 36.521-1, Section 6.2.2F (UE Maximum Output Power for UE Category NB1) using the default settings specified in 3GPP TS 36.521-1 and 3GPP TS 36.508 as applicable and using the uplink reference measurement channels defined in Annex A.2.4 of 3GPP TS 36.521-1 and [Table 5-36](#). The test procedure in section 6.2.2F of 3GPP TS 36.521-1 shall be used to measure the UE output power. TRP measurements shall be executed using the Category NB1 Stand-Alone (SA) mode, using the test channel configuration described in [Table 5-36](#).

Note: as opposed to LTE, the frequency difference between the test channel (i.e., F_{UL}) and the actual center frequency for the subcarrier allocation is very small (<100kHz). Therefore, power measurements shall be done on F_{UL} .

TABLE 5-36 LTE CATEGORY NB1 TRP MEASUREMENTS TABLE FOR STAND-ALONE (SA) OPERATION USING $\pi/4$ QPSK (15 KHZ SUB-CARRIER SPACING) IN THE PRIMARY MECHANICAL MODE¹

Band	Range	NB1 UL EARFCN	UL Offset to NB1 EARFCN	Frequency of NB1 UL EARFCN	Uplink Configuration		Downlink Configuration	
		N_{UL}	M_{UL}	F_{UL} (MHz)	Modulation	N_{tones}	Modulation	Subcarriers
2 ²	Low	18601	0	1850.10	$\pi/4$ QPSK	1@0	N/A ³	N/A ³
2 ²	High	19199	0	1909.90	$\pi/4$ QPSK	1@11	N/A ³	N/A ³
4 ⁴	Low	19951	0	1710.10	$\pi/4$ QPSK	1@0	N/A ³	N/A ³
4 ⁴	High	20399	0	1754.90	$\pi/4$ QPSK	1@11	N/A ³	N/A ³
5 ⁵	Low	20401	0	824.10	$\pi/4$ QPSK	1@0	N/A ³	N/A ³
5 ⁵	High	20649	0	848.90	$\pi/4$ QPSK	1@11	N/A ³	N/A ³
12 ⁶	Low	23011	0	699.10	$\pi/4$ QPSK	1@0	N/A ³	N/A ³
12 ⁶	High	23179	0	715.90	$\pi/4$ QPSK	1@11	N/A ³	N/A ³
13	Low	23181	0	777.10	$\pi/4$ QPSK	1@0	N/A ³	N/A ³
13	High	23279	0	786.90	$\pi/4$ QPSK	1@11	N/A ³	N/A ³
14	Low	23281	0	788.10	$\pi/4$ QPSK	1@0	N/A ³	N/A ³
14	High	23379	0	797.90	$\pi/4$ QPSK	1@11	N/A ³	N/A ³
17 ⁶	Low	23731	0	704.10	$\pi/4$ QPSK	1@0	N/A ³	N/A ³
17 ⁶	High	23849	0	715.90	$\pi/4$ QPSK	1@11	N/A ³	N/A ³
25 ²	Low	26041	0	1850.10	$\pi/4$ QPSK	1@0	N/A ³	N/A ³
25 ²	High	26689	0	1914.90	$\pi/4$ QPSK	1@11	N/A ³	N/A ³
26 ⁵	Low	26691	0	814.10	$\pi/4$ QPSK	1@0	N/A ³	N/A ³
26 ⁵	High	27039	0	848.90	$\pi/4$ QPSK	1@11	N/A ³	N/A ³
66 ⁴	Low	131973	0	1710.10	$\pi/4$ QPSK	1@0	N/A ³	N/A ³
66 ⁴	High	132671	0	1779.90	$\pi/4$ QPSK	1@11	N/A ³	N/A ³
71	Low	133123	0	663.10	$\pi/4$ QPSK	1@0	N/A ³	N/A ³
71	High	133471	0	697.90	$\pi/4$ QPSK	1@11	N/A ³	N/A ³

Note 1: Primary Mechanical Mode refers to device configured in preferred mode per manufacturer instructions (typically means antenna extended, fold or portrait slide open, but depends on form factor).

Note 2: If the device supports Band 25 and Band 2, then testing is only required to be completed in Band 25.

Note 3: As per 3GPP TS 36.521-1, Section 6.2.2F (UE Maximum Output Power for category NB1 and NB2).

Note 4: If the device supports Band 4 and Band 66, then testing is only required to be completed in Band 66.

Note 5: If the device supports Band 26 and Band 5, then testing is only required to be completed in Band 26.

Note 6: If the device supports Band 12 and Band 17, then testing is only required to be completed in Band 12.

5.16.2 Criteria

Results shall be reported as specified in [Appendix B](#) using the figures of merit given in [Appendix B.3](#). [Appendix B.1](#) contains the pass/fail OTA tables for LTE Category NB1.

Pass/fail criteria for LTE Category NB1 is for future study, and different pass/fail criteria may be developed for different device types/use cases. Reports shall include results for applicable use cases, including free-space and/or wrist-worn configurations across all relevant channels measured with the EUT in primary mechanical mode, and (if applicable) in non-primary mechanical modes as reference information.

TABLE 5-37 LTE CATEGORY NB1 TRP LEVEL (DBM) FOR STAND-ALONE (SA) OPERATION USING $\pi/4$ QPSK (15 KHZ SUB-CARRIER SPACING) IN THE PRIMARY MECHANICAL MODE¹

Band	Device Worn on Wrist?	Power Class	FS	WL and WR
LTE Band 71	Yes	3	N/A	TBD
		5	N/A	TBD
	No	3	TBD	N/A
		5	TBD	N/A
LTE Band 12	Yes	3	N/A	TBD
		5	N/A	TBD
	No	3	TBD	N/A
		5	TBD	N/A
LTE Band 13	Yes	3	N/A	TBD
		5	N/A	TBD
	No	3	TBD	N/A
		5	TBD	N/A
LTE Band 14	Yes	3	N/A	TBD
		5	N/A	TBD
	No	3	TBD	N/A
		5	TBD	N/A
LTE Band 17	Yes	3	N/A	TBD
		5	N/A	TBD
	No	3	TBD	N/A
		5	TBD	N/A
LTE Band 26	Yes	3	N/A	TBD
		5	N/A	TBD
	No	3	TBD	N/A
		5	TBD	N/A

TABLE 5-37 LTE CATEGORY NB1 TRP LEVEL (DBM) FOR STAND-ALONE (SA) OPERATION USING $\pi/4$ QPSK (15 KHZ SUB-CARRIER SPACING) IN THE PRIMARY MECHANICAL MODE¹

Band	Device Worn on Wrist?	Power Class	FS	WL and WR
LTE Band 5	Yes	3	N/A	TBD
		5	N/A	TBD
	No	3	TBD	N/A
		5	TBD	N/A
LTE Band 25	Yes	3	N/A	TBD
		5	N/A	TBD
	No	3	TBD	N/A
		5	TBD	N/A
LTE Band 2	Yes	3	N/A	TBD
		5	N/A	TBD
	No	3	TBD	N/A
		5	TBD	N/A
LTE Band 4	Yes	3	N/A	TBD
		5	N/A	TBD
	No	3	TBD	N/A
		5	TBD	N/A
LTE Band 66	Yes	3	N/A	TBD
		5	N/A	TBD
	No	3	TBD	N/A
		5	TBD	N/A

Note 1: Primary Mechanical Mode refers to device configured in preferred mode per manufacturer instructions (typically means antenna extended, fold or portrait slide open, but depends on form factor).

5.17 New Radio (NR) Frequency Range 1 (FR1) (Informative)

5.17.1 Test Procedure

The measurement site and EUT shall be configured as specified in [Appendix A](#). The power radiated by the EUT shall be measured using a calibrated and accurate RF measuring instrument (e.g., a spectrum analyzer, or measurement receiver, or power meter).

Note: See [Appendix D](#) for power measurement considerations.

The NR system simulator and EUT shall be configured per 3GPP TS 38.521-1, Section 6.2 (Transmitter Power) using the default settings specified in 3GPP TS 38.521-1 and 3GPP TS 38.508-1 as applicable. The test procedure in Section 6.2.1 (UE Maximum Output Power) of 3GPP TS 38.521-1 shall be used to measure the UE output power.

Tests shall be carried out for different frequency pairs (FDD; UL -uplink /DL -downlink) or frequencies (TDD) and RB allocations across the bands supported by the EUT, as defined in [Table 5-38](#).

TABLE 5-38 NR FR1 TRP MEASUREMENTS TABLE FOR THE PRIMARY MECHANICAL MODE¹

Band	Channel Bandwidth (MHz)	SCS (kHz)	UL Modulation	UL Channel	Carrier Center Frequency [MHz]	UL RB Allocation	DL Configuration
n2	10	15	DFT-s-OFDM QPSK	371000	1855	25@12	N/A
				376000	1880	25@12	N/A
				381000	1905	25@12	N/A
n5	10	15	DFT-s-OFDM QPSK	165800	829	25@12	N/A
				167300	836.5	25@12	N/A
				168800	844	25@12	N/A
n41	100	30	DFT-s-OFDM QPSK	509202	2546.01	135@67	N/A
				518598	2592.99	135@67	N/A
				528000	2640	135@67	N/A
n66	10	15	DFT-s-OFDM QPSK	343000	1715	25@12	N/A
				349000	1745	25@12	N/A
				355000	1775	25@12	N/A
	20	15	DFT-s-OFDM QPSK	344000	1720	50@25	N/A
				349000	1745	50@25	N/A
				354000	1770	50@25	N/A
	40	15	DFT-s-OFDM QPSK	346000	1730	108@54	N/A
				349000	1745	108@54	N/A
				352000	1760	108@54	N/A

TABLE 5-38 NR FR1 TRP MEASUREMENTS TABLE FOR THE PRIMARY MECHANICAL MODE¹

Band	Channel Bandwidth (MHz)	SCS (kHz)	UL Modulation	UL Channel	Carrier Center Frequency [MHz]	UL RB Allocation	DL Configuration
n70	5	15	DFT-s-OFDM QPSK	339500	1697.5	12@6	N/A
	15			340500	1702.5	36@18	N/A
	5			341500	1707.5	12@6	N/A
n71	10	15	DFT-s-OFDM QPSK	133600	668	25@12	N/A
				136100	680.5	25@12	N/A
				138600	693	25@12	N/A
n78	60	30	DFT-s-OFDM QPSK	622000	3330	81@40	N/A
				636666	3549.99	81@40	N/A
				651332	3769.98	81@40	N/A
	100	30	DFT-s-OFDM QPSK	623334	3350.01	135@67	N/A
				636666	3549.99	135@67	N/A
				650000	3750	135@67	N/A

Note 1: Primary Mechanical Mode refers to device configured in preferred mode per manufacturer instructions (typically means antenna extended, fold or portrait slide open, but depends on form factor).

Head and hand phantom, hand phantom only and/or free-space testing shall be conducted based on device type, as specified in [Appendix O](#). Refer to [Appendix C](#) for head/hand testing requirements. Perform each test on all specified frequencies and RB allocations with the EUT antenna extended and retracted, as applicable.

Note: Head-adjacent testing is only required for NR if the EUT supports usage against the head while utilizing an NR airlink (e.g., VoIP).

5.17.2 Criteria

Pass/fail criteria for NR FR1 is for future study, and different pass/fail criteria may be developed for different device types/use cases.

Section 6 Test Procedure—Receiver Performance

Products supporting multiple air-interface technologies shall be tested in accordance with all relevant test procedures. Test results will be provided for each test performed in the format defined in [Appendix B](#).

Receiver Sensitivity procedures will utilize the same spherical measurement procedure as specified for the Transmitter power measurements in [Section 5](#) with the exception of angular step size. Receiver Performance measurements may be made simultaneously with tests performed in [Section 5](#). For measurements not made in conjunction, test setups and frequencies designated CHn-Rx and given in the tables within [Section 5](#) should be used.

Total Isotropic Sensitivity (TIS) shall be fully measured as described above and calculated pursuant to [Appendix B.3](#) for the channel(s) specified in [Section 5](#) for all frequency bands supported by the EUT and required to be tested per this test plan. All of the remaining intermediate channels must each be evaluated for relative sensitivity or fully measured TIS. In the case of fully measured TIS, the same limit as that channel's reference channel shall be applied with a 3 dB margin as per the intermediate channel test procedure. Regardless of test method, intermediate channel results shall be reported as PASS/FAIL per [Appendix B.1](#), Table B-21. The intermediate channel test is to be done by comparison of the fully measured channel(s) with the intermediate channels measured. Since some digital technologies have a very large number of intermediate channels, some channels may be omitted from actual testing. The combination of intermediate channels that must be evaluated will be specific to each different air interface. In the case of GNSS testing, the intermediate channels are utilized to determine if the wireless operation of the EUT interferes with the GNSS sensitivity performance of the EUT. Refer to [Appendix E](#) for details on TIS. Refer to [Appendix K](#) for details on the intermediate channels to be tested for each air interface.

For all air interfaces and devices, TIS shall be measured with all receivers active. This measurement method and result is referred to as Combined Total Isotropic Sensitivity, or C-TIS. The C-TIS test is agnostic to whether the device under test actually has only one or multiple receivers; all that matters is that the receivers are all active during the test. The performance metrics (pass/fail criteria) are given in terms of C-TIS for all device types. Different categories of devices, having differing performance expectations based on e.g., number of receivers, may be defined, each having its own appropriate pass/fail criteria expressed in terms of C-TIS.

To accommodate the possibility that special cases may arise where an operator or manufacturer may want to measure a device with multiple receivers with measuring one receiver at a time (other receivers disabled), individually measured TIS, referred to as I-TIS, may be reported as supplemental information. I-TIS results can be mathematically combined to produce an estimated C-TIS value for a device, following the equation shown below.

EQUATION 6.1

$$\frac{1}{TIS_C} = \frac{1}{TIS_0} + \frac{1}{TIS_1}$$

This approach shall not be used for certification purposes.

As required in [Appendix O](#), units shall be tested in free-space, with head and hand phantom, and/or with hand phantom only as described in [Appendix C](#), for the full TIS test. The intermediate channel tests will be limited to the right side head and hand phantom (BHHR) and free space test configurations, as applicable from [Appendix O](#), for cellular technologies. Intermediate Channel Degradation testing for

GNSS shall be tested in the right side head and hand phantom and right hand phantom only configurations as described in [Appendix C](#). A base station simulator appropriate for the air-interface is required for these tests and will be used to report the digital error rate found by the EUT. The EUT will be placed in an active call on the specified test channel(s), and in the specified test conditions. The RF power level of the base station simulator will then be adjusted to achieve the desired digital error rate at each measured location on the sphere. The digital error rate from the EUT will be extracted from the base station simulator or directly from the EUT, where applicable. In general, a sufficient number of bits, packets or frames will be sampled such that the confidence interval in digital error rate is 95% or better.

Since the process of measuring effective radiated receiver sensitivity is typically less accurate than measuring transmitter radiated power, this test specification allows for a relaxation in the spatial separation to 30 degrees in the theta (θ) and in the phi (ϕ) axis for TIS²; as noted in [Section 2.2](#).

Please note the following abbreviations in this section:

FS = Free Space

BH = Beside Head (Head Phantom Only)

BHL = Beside Head Left Side (Head Phantom Only)

BHR = Beside Head Right Side (Head Phantom Only)

HL = Hand Left (Hand Phantom Only)

HR = Hand Right (Hand Phantom Only)

BHHL = Beside Head and Hand Left Side (Head and Hand Phantom)

BHHR = Beside Head and Hand Right Side (Head and Hand Phantom)

WL = Wrist-Worn Left (Forearm Phantom)

WR = Wrist-Worn Right (Forearm Phantom)

6.1 AMPS

This section removed for V3.1.

6.2 CDMA

6.2.1 Test Procedure

Receiver Sensitivity measurements shall be performed using the Base Station Simulator to determine the EUT's receiver sensitivity by reporting the minimum forward-link power resulting in a Frame Error Rate (FER) of 0.5% or less with 95% confidence. Refer to [Appendix A](#) for set-up illustrations.

2. The goal of the receiver test is to find TIS with a minimum measurement uncertainty of no more than the values specified in [Table 7-8](#) with a confidence of 95%. The use of a 30-degree sampling increment has been shown to contribute on the order of ± 0.5 dB or less to this error in TIS for the Cellular and PCS bands, and is therefore acceptable. 30-degree sampling is not considered acceptable for accurately capturing peak field quantities at these frequencies (only integrated quantities like TIS), but that is not what is required for this test. Future extension of this test plan to higher frequencies would require revisiting this sampling issue at those frequencies.

The set-up parameters defined in [Section 5.2](#) shall be used with the following exceptions:

- Forward-Link Power: As needed to maintain 0% FER
- Power Control: Closed Loop
- All other parameters shall be set according to TIA-98-E paragraph 3.5.1 for the Receiver Sensitivity test and to the defaults specified in TIA-98-E paragraph 6.5.2.

Note: *If the test point is occurring in a significant null, the forward-link power may have to be raised to establish/maintain a call.*

For a device supporting multiple receivers, all receivers shall be enabled during the test procedure described in the remainder of this section. In this way, C-TIS is the test result, regardless whether the device supports one or multiple receivers. In the special case that I-TIS is the desired quantity of interest, the same procedure is followed, except that all but the specified receiver-under-test on the device are disabled.

Page the EUT and direct it to one of the reference test channels. With a digital voice/traffic channel established, invoke an FER Measurement.

Sensitivity measurements shall be equivalent to the minimum RF power level that results in an FER of 0.5% or less with 95% confidence at each measured location on the sphere. The algorithms/methods used to arrive at these results can be optimized for speed by finding alternate points on the FER curve as long as the data is eventually normalized to a data set equivalent to 0.5% or less at each data point. Alternative points on the FER curve greater than 2% shall not be used. The normalization value shall be determined in the same test configuration used to make the other FER measurements (i.e. over-the-air, CDMA set-up parameters, etc.) and shall be derived from an actual sensitivity measurement of 0.5% FER or less with 95% confidence and not an interpolation. In either case, the appropriate contribution to the measurement uncertainty shall be included. Refer to [Section 6.15.1](#) for details on this procedure and [Section 7.4](#) for details on this measurement uncertainty. The number of frames observed shall be consistent with a 95% confidence level but may be limited to 500 frames maximum at 2% FER and to 2000 frames maximum at 0.5% FER. For FER's in between these two points, the maximum number of frames shall be scaled proportionally. The forward-link power step size shall be no more than 0.5 dB when the RF power level is near the CDMA sensitivity level. The Power Control setting shall be changed to Always Up when the final sensitivity measurement is made for each test point. The Forward-Link Power and the Power Control settings should be set back to defaults prior to tuning to the next test point. The minimum RF power level resulting in an FER of 0.5% or less for each EUT test condition shall be recorded for integration pursuant to [Appendix B.3](#) to give a single figure of merit referred to as Total Isotropic Sensitivity (TIS).

Typically, the maximum deviation in RX level measurements from peak to null of any one channel does not exceed 30 dB. Therefore, the test facility may elect to initiate each sensitivity measurement starting with the base station power set 30 dB above the lowest sensitivity level measured in order to reduce the time required to search for the sensitivity floor. For points where this setting is below the target sensitivity level, the sensitivity may be considered negligible for that location and the initial value used in place of an actual measurement.

TIS shall be fully measured as described above and calculated pursuant to [Appendix B.3](#) for the three channels (low, middle and high) specified in [Section 5](#) for all frequency bands supported by the EUT and required to be tested per this test plan.

Relative sensitivity measurements or fully measured TIS shall be repeated per channel on a specified list of intermediate channels as shown in [Appendix K.1](#). The separation between channels is no greater than 500 kHz, and the intermediate channels are based on the frequency of the center channel.

When full TIS measurements are performed on intermediate channels, the intermediate channel passes if the full TIS result is better than 1) the TIS limit or 2) the TIS result at either of the neighboring reference channels plus 1 dB. The full TIS results at the intermediate channels may be included as additional data and marked as supplemental in the test report.

Procedure for measuring relative sensitivity on intermediate channels (refer to [Figure 6-1](#)):

1. Move the EUT and chamber positioner(s) to the location & polarization resulting in the best-radiated free-space sensitivity measured for the closest, in frequency, fully measured channel (low, mid, high), now used as a Reference Channel.
2. Note the downlink power level which corresponds to the EUT's peak free-space radiated sensitivity as described in step 1 above, which will be referred to as FS EIS_(peak low). Next, determine the margin, M1_{low}, in dB, between the EUT's measured TIS and the corresponding TIS limit in [Table 6-1](#). If the device doesn't meet the required TIS limit, then set M1_{low}=0. Adjust the digital call simulator to the RF power level calculated by the following formula:

EQUATION 6.1

$$\text{Downlink Signal Power}_{\text{low}} \text{ (dBm)} = \text{FS EIS}_{(\text{peak low})} \text{ (dBm)} + \text{M1}_{\text{low}} \text{ (dB)} + 3 \text{ (dB)}$$

For example, if the EUT's FS EIS_(peak low) was -108 dBm on the low-frequency reference channel, the EUT's low-frequency reference channel FS TIS was -104 dBm, and the FS TIS limit is -100 dBm, we have:

$$(-108 \text{ (dBm)} + 4 \text{ (dB)} + 3 \text{ (dB)}) \text{ dBm} = -101 \text{ dBm}$$

In this example, the signal generator would be set to -101 dBm for all intermediate channels associated with the low-frequency reference channel as shown in [Figure 6-1](#). Similar evaluations are performed for mid and high reference channels. Note that M1_{low}, M1_{mid}, and M1_{high} can vary depending on how much the FS TIS of each channel exceeds the FS TIS limit.

3. Without changing the RF signal level at the EUT, change the frequency of the base station simulator such that it is operating on a defined intermediate channel.
4. Using the base station simulator, measure the FER using the required number of frames as described above. The measured FER must not exceed 0.5%.
5. Repeat steps 3 through 4 of this procedure for all remaining intermediate channels. If the reference channel changes from low to mid or high, move to the location and polarization of the next reference channel (mid, high), see step 1, and take the EUT's measured FS TIS and BHHR TIS on the low, mid and high-frequency reference channels into account when calculating the downlink signal power level according to [Equation 6.1](#) in step 2.
6. Report the free-space pass/fail status of each intermediate channel listed in [Appendix K.1](#) For both the full TIS test and the intermediate channel tests, free-space testing shall be conducted based on device type, as specified in [Appendix O](#). Perform each test on all specified frequencies with the EUT antenna extended and retracted, as applicable.
7. If the device must be tested in the BHHR position, then move the EUT and chamber positioner(s) to the location and polarization resulting in the best-radiated BHHR sensitivity measured for the closest, in frequency, fully measured channel (low, mid, high), now used as a Reference Channel.
8. Devices which must be tested in the BHHR position shall be evaluated for intermediate channel performance using a Pass/Fail limit provided by the following formula:

EQUATION 6.2

$$\text{BHHR TIS Pass/Fail limit}_{\text{low}} (\text{dBm}) = \text{FS TIS Pass/Fail limit} (\text{dBm}) + (\text{EUT BHHR TIS}_{\text{low}} (\text{dBm}) - \text{EUT FS TIS}_{\text{low}} (\text{dBm}))$$

For example, if the FS TIS limit is -100 dBm, the EUT BHHR TIS on the low-frequency reference channel is -99 dBm, and the EUT FS TIS on the low-frequency reference channel is -104 dBm, we have:

$$(-100 (\text{dBm}) + (-99 (\text{dBm}) - (-104 (\text{dBm}))) \text{ dBm} = -95 \text{ dBm}$$

In this example, -95 dBm would be the BHHR TIS Pass/Fail Limit_{low} used when repeating steps 1 through 6 above with the EUT in the BHHR position for all intermediate channels associated with the low-frequency reference channel as shown in [Figure 6-1](#).

Similar evaluations are performed for mid and high reference channels. Note that BHHR TIS Pass/Fail limit_{low}, BHHR TIS Pass/Fail limit_{mid} and BHHR TIS Pass/Fail limit_{high} can be different.

9. Note the downlink power level which corresponds to the EUT's peak BHHR radiated sensitivity as described in step 7 above, which will be referred to as BHHR EIS_(peak low). Since the BHHR TIS Pass/Fail limit_{low} is directly derived from the FS limit and the TIS difference, see [Equation 6.2](#), the same margin M1_{low} is to be used. Adjust the digital call simulator to the RF power level calculated by the following formula:

EQUATION 6.3

$$\text{Downlink Signal Power}_{\text{low}} (\text{dBm}) = \text{BHHR EIS}_{(\text{peak low})} (\text{dBm}) + \text{M1}_{\text{low}} (\text{dB}) + 3 (\text{dB})$$

For example, if the EUT's BHHR EIS_(peak low) was -100 dBm on the low-frequency reference channel, the EUT's low-frequency reference channel BHHR TIS low was -96 dBm, and the BHHR TIS low limit is -92 dBm, we have:

$$(-100 (\text{dBm}) + 4 (\text{dB}) + 3 (\text{dB})) \text{ dBm} = -93 \text{ dBm}$$

In this example, the signal generator would be set to -93 dBm for all intermediate channels associated with the low-frequency reference channel as shown in [Figure 6-1](#). Similar evaluations are performed for mid and high reference channels.

10. Without changing the RF signal level, change the frequency of the base station simulator such that it is operating on a defined intermediate channel.
11. Using the base station simulator, measure the FER using the required number of frames as described above. The measured FER must not exceed 0.5%.
12. Repeat steps 10 through 11 of this procedure for all remaining intermediate channels. If the reference channel changes from low to mid or high, move to the location and polarization of the next reference channel (mid, high), see step 7, and take the EUT's measured FS TIS and BHHR TIS on the low, mid and high-frequency reference channels into account when calculating the downlink signal power level according to [Equation 6.3](#) in step 9.
13. Report the BHHR pass/fail status of each intermediate channel listed in [Appendix K.1](#). For both the full TIS test and the intermediate channel tests, head/hand testing shall be conducted based on device type, as specified in [Appendix O](#). Refer to [Appendix C](#) for head/hand testing requirements. Perform each test on all specified frequencies with the EUT antenna extended and retracted, as applicable.
14. The methodology in step 8 shall be applied to determine the TIS Pass/Fail Limits for all non-primary mechanical modes, if applicable, for the purpose of performing the intermediate channel desense test.

Figure 6-1 is an illustration of relative sensitivity on intermediate channels test. The green lines indicate a pass-fail test performed (margin + 3) dB above the corresponding EIS level of the nearest channel for which a full TIS measurement was performed.

FIGURE 6-1 ILLUSTRATION OF RELATIVE SENSITIVITY ON INTERMEDIATE CHANNELS TEST

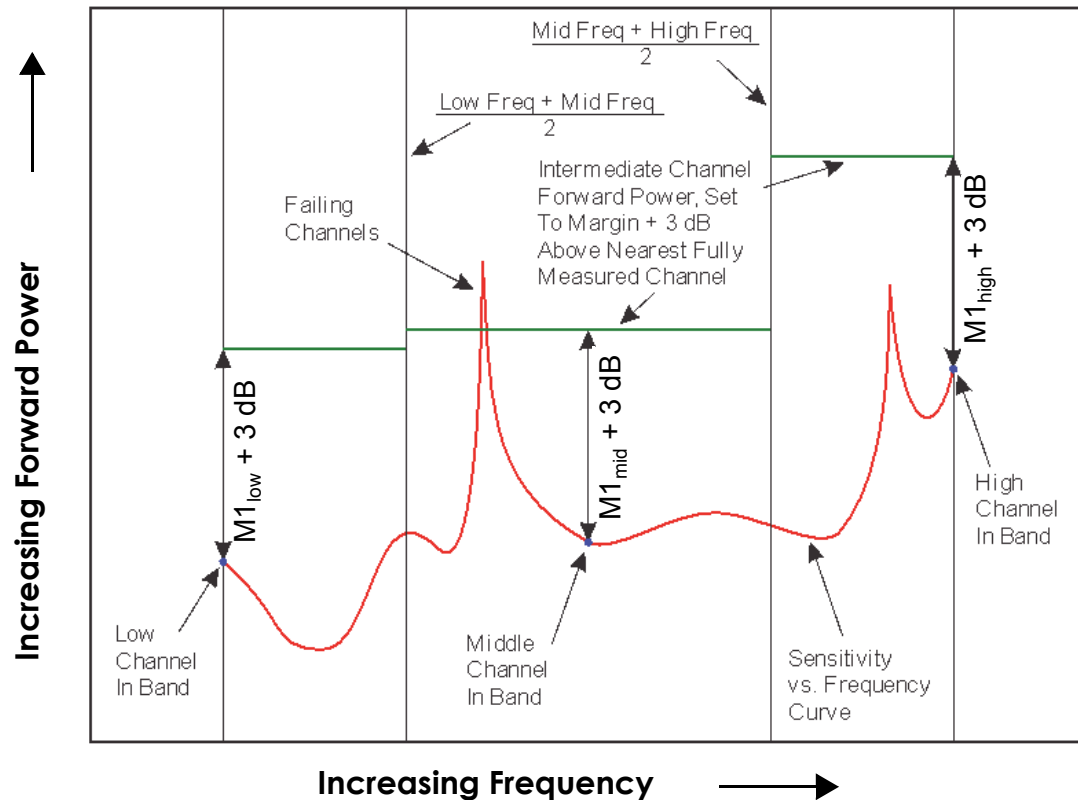

For the full TIS test, head/hand and/or free-space testing shall be conducted based on device type, as specified in [Appendix O](#). For the intermediate channel tests, head and hand phantom and free-space test configurations shall be conducted based on device type, as specified in [Appendix O](#). Refer to [Appendix C](#) for head/hand testing requirements. Perform each test on all specified frequencies with the EUT antenna extended and retracted, as applicable.

6.2.2 Criteria

Results shall be reported as specified in [Appendix B](#) using the figures of merit given in [Appendix B.3](#). [Appendix B.1](#) contains the pass/fail OTA tables for CDMA. Reports shall include results for free-space and simulated-use configurations (if applicable) across all channels measured with the EUT antenna extended and retracted.

Relative sensitivity on intermediate channels test results shall be provided in a file format equivalent to that specified in [Appendix B.1](#)

TABLE 6-1 CDMA MAXIMUM C-TIS LEVEL (IN DBM) REQUIREMENTS FOR THE PRIMARY MECHANICAL MODE¹

Band	Device Held Up to Head for Voice (Yes/No)	Antenna Type	Device Width (mm) ²	FS	BHHL and BHRH	HL and HR
CDMA 800	Yes ³	Embedded	≤72	-101	TBD	TBD
			>72	-101	TBD	TBD
		Stub or Retractable	≤72	-101	TBD	TBD
			>72	-101	TBD	TBD
	No ⁴	All	All	-101	N/A	N/A
CDMA 1900	Yes ³	Embedded	≤72	-101	TBD	TBD
			>72	-101	TBD	TBD
		Stub or Retractable	≤72	-101	TBD	TBD
			>72	-101	TBD	TBD
	No ⁴	All	All	-101	N/A	N/A
CDMA 2100/1700	Yes ³	Embedded	≤72	-101	TBD	TBD
			>72	-101	TBD	TBD
		Stub or Retractable	≤72	-101	TBD	TBD
			>72	-101	TBD	TBD
	No ⁴	All	All	-101	N/A	N/A

Note 1: Primary Mechanical Mode refers to device configured in preferred mode per manufacturer instructions (typically means antenna extended, fold or portrait slide open, but depends on form factor).
 Note 2: Differences between requirements for devices wider and narrower than 72 mm reflect observed differences in OTA performance with different hand phantoms of up to 6 dB.
 Note 3: "Yes" applies if the device supports voice operation in the talking position against the head in any cellular radio mode.
 Note 4: "No" would be applicable to data-centric devices that are not held up against the head, e.g., embedded laptop solutions.

6.3 TDMA

This section removed for V3.1.

6.4 GSM

6.4.1 Test Procedure

Receiver Sensitivity measurements shall be performed using the Base Station Simulator to determine the EUT's receiver sensitivity by reporting the minimum forward-link power resulting in a Class II Residual Bit Error Rate (RBER) of 2.44% or less with 95% confidence. Refer to [Appendix A](#) for set-up illustrations.

The set-up parameters defined in [Section 5.4](#) shall be used with the following exceptions:

- a. Forward-Link Power: As needed to maintain 0% RBER
- b. Power Control Level (PCL) adjusted high enough to ensure that there are no communication errors introduced on the reverse channel. The EUT does not need to be set to maximum power at the initiation of the sensitivity search.
- c. The base station simulator shall configure the EUT for loopback mode. Refer to 3GPP TS 05.05 and 3GPP TS 51.010-1 for procedures and criteria for the setup of loopback mode.

Note: *If the test point is occurring in a significant null, the forward-link power may have to be raised to establish/maintain a call.*

For a device supporting multiple receivers, all receivers shall be enabled during the test procedure described in the remainder of this section. In this way, C-TIS is the test result, regardless whether the device supports one or multiple receivers. In the special case that I-TIS is the desired quantity of interest, the same procedure is followed, except that all but the specified receiver-under-test on the device are disabled.

Page the EUT and direct it to one of the reference test channels. With a digital voice/traffic channel established, invoke an RBER Measurement.

Sensitivity measurements shall be equivalent to the minimum RF power level that results in a Class II RBER of 2.44% or less with 95% confidence at each measured location on the sphere. The algorithms/methods used to arrive at these results can be optimized for speed by finding alternate points on the BER curve as long as the data is eventually normalized to a value equivalent to 2.44% or less at each data point. The normalization value shall be determined in the same test configuration used to make the other BER measurements (i.e. over-the-air, GSM set-up parameters, etc.) and shall be derived from an actual sensitivity measurement of 2.44% BER or less with 95% confidence and not based on an interpolation. In either case, the appropriate contribution to the measurement uncertainty shall be included. Refer to [Section 6.15.1](#) for details on this procedure and [Section 7.4](#) for details on this measurement uncertainty. The number of frames observed shall be consistent with a 95% confidence level but may be limited to 135 frames maximum. The forward power step size shall be no more than 0.5 dB when the RF power level is near the target sensitivity level. The Power Control Level setting shall be changed to maximum power when the final sensitivity measurement is made for each test point, as well as when any BER reference curve is generated. The Forward Link Power and the Power Control Level settings should be set back to defaults prior to tuning to the next test point. The minimum RF power level resulting in a Class II RBER of 2.44% or less for each EUT test condition shall be recorded for integration pursuant to [Appendix B.3](#) to give a single figure of merit referred to as Total Isotropic Sensitivity (TIS).

Typically, the maximum deviation in RX level measurements from peak to null of any one channel does not exceed 30 dB. Therefore, the test facility may elect to initiate each sensitivity measurement starting with the base station power set 30 dB above the lowest sensitivity level measured in order to reduce the time required to search for the sensitivity floor. For points where this setting is below the target sensitivity

level, the sensitivity may be considered negligible for that location and the initial value used in place of an actual measurement.

TIS shall be fully measured as described above and calculated pursuant to [Appendix B.3](#) for the 3 channels (low, middle and high) specified in [Section 5](#) for all frequency bands supported by the EUT and required to be tested per this test plan.

Relative sensitivity measurements or fully measured TIS will be repeated per channel on all channels.

When full TIS measurements are performed on intermediate channels, the intermediate channel passes if the full TIS result is better than 1) the TIS recommended limit or 2) the TIS result at either of the neighboring reference channels plus 1 dB. The full TIS results at the intermediate channels may be included as additional data and marked as supplemental in the test report.

1. Move the EUT and chamber positioner(s) to the location & polarization resulting in the best-radiated free-space sensitivity measured for the closest, in frequency, fully measured channel (low, mid, high), now used as a Reference Channel.
2. Note the downlink power level which corresponds to the EUT's peak free-space radiated sensitivity as described in step 1 above, which will be referred to as FS EIS_(peak low). Next, determine the margin, M1_{low}, in dB, between the EUT's measured TIS and the corresponding TIS limit in [Table 6-2](#). If the device doesn't meet the required TIS limit, then set M1_{low}=0. Adjust the digital call simulator to the RF power level calculated by the following formula:

EQUATION 6.4

$$\text{Downlink Signal Power}_{\text{low}} \text{ (dBm)} = \text{FS EIS}_{(\text{peak low})} \text{ (dBm)} + \text{M1}_{\text{low}} \text{ (dB)} + 3 \text{ (dB)}$$

For example, if the EUT's FS EIS_(peak low) was -108 dBm on the low-frequency reference channel, the EUT's low-frequency reference channel FS TIS_{low} was -104 dBm, and the FS TIS limit is -100 dBm, we have:

$$(-108 \text{ (dBm)} + 4 \text{ (dB)} + 3 \text{ (dB)}) \text{ dBm} = -101 \text{ dBm}$$

In this example, the signal generator would be set to -101 dBm for all intermediate channels associated with the low-frequency reference channel as shown in [Figure 6-1](#). Similar evaluations are performed for mid and high reference channels. Note that M1_{low}, M1_{mid}, and M1_{high} can vary depending on how much the FS TIS of each channel exceeds the FS TIS limit.

3. Without changing the RF signal level at the EUT, change the frequency of the base station simulator such that it is operating on a defined intermediate channel.
4. Using the base station simulator, measure the Class II RBER using the required number of frames as described above. The measured RBER must not exceed 2.44%.
5. Repeat steps 3 through 4 of this procedure for all remaining intermediate channels. If the reference channel changes from low to mid or high, move to the location and polarization of the next reference channel (mid, high), see step 1, and take the EUT's measured FS TIS and BHHR TIS on the low, mid and high-frequency reference channels into account when calculating the downlink signal power level according to [Equation 6.4](#) in step 2.
6. Report the free-space pass/fail status of each intermediate channel listed in [Appendix K.2](#) For both the full TIS test and the intermediate channel tests, free-space testing shall be conducted based on device type, as specified in [Appendix O](#). Perform each test on all specified frequencies with the EUT antenna extended and retracted, as applicable.
7. If the device must be tested in the BHHR position, then move the EUT and chamber positioner(s) to the location and polarization resulting in the best-radiated BHHR sensitivity

measured for the closest, in frequency, fully measured channel (low, mid, high), now used as a Reference Channel.

8. Devices which must be tested in the BHRH position shall be evaluated for intermediate channel performance using a Pass/Fail limit provided by the following formula:

EQUATION 6.5

$$\text{BHRH TIS Pass/Fail limit}_{\text{low}} (\text{dBm}) = \text{FS TIS Pass/Fail limit} (\text{dBm}) + (\text{EUT BHRH TIS}_{\text{low}} (\text{dBm}) - \text{EUT FS TIS}_{\text{low}} (\text{dBm}))$$

For example, if the FS TIS limit is -100 dBm, the EUT BHRH TIS_{low} on the low-frequency reference channel is -99 dBm, and the EUT FS TIS_{low} on the low-frequency reference channel is -104 dBm, we have:

$$(-100 (\text{dBm}) + (-99 (\text{dBm}) - (-104 (\text{dBm}))) \text{ dBm} = -95 \text{ dBm}$$

In this example, -95 dBm would be the BHRH TIS Pass/Fail Limit_{low} used when repeating steps 1 through 6 above with the EUT in the BHRH position for all intermediate channels associated with the low-frequency reference channel as shown in [Figure 6-1](#).

Similar evaluations are performed for mid and high reference channels. Note that BHRH TIS Pass/Fail limit_{low}, BHRH TIS Pass/Fail limit_{mid} and BHRH TIS Pass/Fail limit_{high} can be different.

9. Note the downlink power level which corresponds to the EUT's peak BHRH radiated sensitivity as described in step 7 above, which will be referred to as BHRH EIS_(peak low). Since the BHRH TIS Pass/Fail limit_{low} is directly derived from the FS limit and the TIS difference, see [Equation 6.5](#), the same margin M1_{low} is to be used. Adjust the digital call simulator to the RF power level calculated by the following formula:

EQUATION 6.6

$$\text{Downlink Signal Power}_{\text{low}} (\text{dBm}) = \text{BHRH EIS}_{(\text{peak low})} (\text{dBm}) + \text{M1}_{\text{low}} (\text{dB}) + 3 (\text{dB})$$

For example, if the EUT's BHRH EIS_(peak low) was -100 dBm on the low-frequency reference channel, the EUT's low-frequency reference channel BHRH TIS_{low} was -96 dBm, and the BHRH TIS_{low} limit is -92 dBm, we have:

$$(-100 (\text{dBm}) + 4 (\text{dB}) + 3 (\text{dB})) \text{ dBm} = -93 \text{ dBm}$$

In this example, the signal generator would be set to -93 dBm for all intermediate channels associated with the low-frequency reference channel as shown in [Figure 6-1](#). Similar evaluations are performed for mid and high reference channels.

10. Without changing the RF signal level, change the frequency of the base station simulator such that it is operating on a defined intermediate channel.
11. Using the base station simulator, measure the Class II RBER using the required number of frames as described above. The measured RBER must not exceed 2.44%.
12. Repeat steps 10 through 11 of this procedure for all remaining intermediate channels. If the reference channel changes from low to mid or high, move to the location and polarization of the next reference channel (mid, high), see step 7, and take the EUT's measured FS TIS and BHRH TIS on the low, mid and high-frequency reference channels into account when calculating the downlink signal power level according to [Equation 6.6](#) in step 9.
13. Report the BHRH pass/fail status of each intermediate channel listed in [Appendix K.2](#). For both the full TIS test and the intermediate channel tests, head/hand testing shall be conducted based on device type, as specified in [Appendix O](#). Refer to [Appendix C](#) for head/hand testing requirements. Perform each test on all specified frequencies with the EUT antenna extended and retracted, as applicable.

14. The methodology in step 8 shall be applied to determine the TIS Pass/Fail Limits for all non-primary mechanical modes for the purpose of performing the intermediate channel desense test.

For the full TIS test, head/hand and/or free-space testing shall be conducted based on device type, as specified in [Appendix O](#). For the intermediate channel tests, head and hand phantom and free-space test configurations shall be conducted based on device type, as specified in [Appendix O](#). Refer to [Appendix C](#) for head/hand testing requirements. Perform each test on all specified frequencies with the EUT antenna extended and retracted, as applicable.

6.4.2 Criteria

Results shall be reported as specified in [Appendix B](#) using the figures of merit given in [Appendix B.3](#). [Appendix B.1](#) contains the pass/fail OTA tables for GSM. Reports shall include results for free-space and head/hand configurations (if applicable) across all channels measured with the EUT antenna extended and retracted.

The limits in [Table 6-2](#) are recommended. However, they shall be used to determine the mandatory pass/fail limits for the intermediate channel desense tests.

Relative sensitivity on intermediate channels test results shall be provided in a file format specified in [Appendix B.1](#). The reported RF level that produces a 2.44% RBER for each channel shall be less than the level determined in [Section 6.4.1](#).

TABLE 6-2 GSM MAXIMUM C-TIS LEVEL (IN dBm) RECOMMENDED LIMITS FOR THE PRIMARY MECHANICAL MODE¹

Band	Device Held Up to Head for Voice (Yes/No)	Device Power Class	Device Width (mm) ²	FS	BHHL and BHHR	HL and HR ³
GSM 850	Yes ⁴	2	≤72	-99	TBD	N/A
			>72	-99	TBD	N/A
		3	≤72	-99	TBD	N/A
			>72	-99	TBD	N/A
		4	≤72	-99	TBD	N/A
			>72	-99	TBD	N/A
		5	≤72	-99	TBD	N/A
			>72	-99	TBD	N/A
	No ⁵	2	All	-99	N/A	N/A
		3	All	-99	N/A	N/A
		4	All	-99	N/A	N/A
		5	All	-99	N/A	N/A

TABLE 6-2 GSM MAXIMUM C-TIS LEVEL (IN dBm) RECOMMENDED LIMITS FOR THE PRIMARY MECHANICAL MODE¹

Band	Device Held Up to Head for Voice (Yes/No)	Device Power Class	Device Width (mm) ²	FS	BHHL and BHR	HL and HR ³
GSM 1900	Yes ⁴	1	≤72	-101.5	TBD	N/A
			>72	-101.5	TBD	N/A
		2	≤72	-101.5	TBD	N/A
			>72	-101.5	TBD	N/A
		3	≤72	-101.5	TBD	N/A
			>72	-101.5	TBD	N/A
	No ⁵	1	All	-101.5	N/A	N/A
		2	All	-101.5	N/A	N/A
		3	All	-101.5	N/A	N/A

Note 1: Primary Mechanical Mode refers to device configured in preferred mode per manufacturer instructions (typically means antenna extended, fold or portrait slide open, but depends on form factor).
 Note 2: Differences between requirements for devices wider and narrower than 72 mm reflect observed differences in OTA performance with different hand phantoms of up to 6 dB.
 Note 3: GSM HL and HR tests are optional and are currently not a requirement of this Test Plan, but may be used for single and multiple offset point reference tests including GPRS/EGPRS.
 Note 4: "Yes" applies if the device supports voice operation in the talking position against the head in any cellular radio mode.
 Note 5: "No" would be applicable to data-centric devices that are not held up against the head, e.g., embedded laptop solutions.

6.5 GPRS

6.5.1 Test Procedure

GPRS Receiver Sensitivity measurements shall be performed using a GPRS-capable Base Station Simulator to determine the EUT's receiver sensitivity by reporting the minimum forward-link power resulting in a Block Error Rate (BLER) of 10% or less. Refer to [Appendix A](#) for set-up illustrations.

The set-up parameters defined in [Section 5.5](#) shall be used with the following exceptions:

- Forward-Link Power: As needed to maintain 0% BLER at CS-1.
- Power Control Level (PCL)/Gamma adjusted to ensure that there are no communication errors introduced on the reverse channel. The EUT does not need to be set to maximum power at the initiation of the sensitivity search.
- The GPRS base station simulator shall configure the EUT for GPRS data loopback mode. Refer to 3GPP TS 05.05 and 3GPP TS 51.010-1 for procedures and criteria for the setup of loopback mode.
- The GPRS base station simulator shall be configured to transmit with the maximum number of downlink slots supported by the EUT.

Note: *If the test point is occurring in a significant null, the forward-link power may have to be raised to establish/maintain an active data loopback session.*

For a device supporting multiple receivers, all receivers shall be enabled during the test procedure described in the remainder of this section. In this way, C-TIS is the test result, regardless whether the device supports one or multiple receivers. In the special case that I-TIS is the desired quantity of interest, the same procedure is followed, except that all but the specified receiver-under-test on the device are disabled.

Invoke a GPRS loopback session between the EUT and the GPRS base station simulator on one of the reference test channels. Verify that the GPRS base station simulator is utilizing CS-1 coding on the downlink. With an active data loopback session established, invoke a BLER Measurement.

Sensitivity measurements shall be equivalent to the minimum RF power level that results in a BLER of 10% or less with 95% confidence but may be limited to 2000 received blocks maximum at each measured location on the sphere. If the alternate/normalization method is not used, the number of blocks may be limited to 200 at each measured location on the sphere. The algorithms/methods used to arrive at these results can be optimized for speed by finding alternate points on the BLER curve as long as the data is eventually normalized to a value equivalent to 10% or less at each data point. The normalization value shall be determined in the same test configuration used to make the other BLER measurements (i.e. over-the-air, GSM set-up parameters, etc.) and shall be derived from an actual sensitivity measurement of 10% BLER or less with 95% confidence but may be limited to 2000 received blocks maximum and not based on an interpolation. In either case, the appropriate contribution to the measurement uncertainty shall be included. Refer to [Section 6.15.1](#) for details on this procedure and [Section 7.4](#) for details on this measurement uncertainty. The forward power step size shall be no more than 0.5 dB when the RF power level is near the target sensitivity level. The Power Control Level/Gamma setting shall be changed to maximum power when the final sensitivity measurement is made for each test point, as well as when any BLER reference curve is generated.

The Forward Link Power, the Power Control Level/Gamma settings should be set back to defaults prior to tuning to the next test point. The minimum RF power level resulting in a BLER of 10% or less for each EUT test condition shall be recorded for integration pursuant to [Appendix B.3](#) to give a single figure of merit referred to as Total Isotropic Sensitivity (TIS).

Typically, the maximum deviation in RX level measurements from peak to null of any one channel does not exceed 30 dB. Therefore, the test facility may elect to initiate each sensitivity measurement starting with the base station power set 30 dB above the lowest sensitivity level measured in order to reduce the time required to search for the sensitivity floor. For points where this setting is below the target sensitivity level, the sensitivity may be considered negligible for that location and the initial value used in place of an actual measurement.

TIS shall be fully measured as described above and calculated pursuant to [Appendix B.3](#) for the 3 channels (low, middle and high) specified in [Section 5](#) for all frequency bands supported by the EUT and required to be tested per this test plan.

Relative sensitivity measurements or fully measured TIS will be repeated per channel on all channels. Reference channel and intermediate channel measurements shall be actual sensitivity measurements of 10% BLER or less with 95% confidence but may be limited to 2000 received blocks maximum.

When full TIS measurements are performed on intermediate channels, the intermediate channel passes if the full TIS result is better than 1) the TIS recommended limit or 2) the TIS result at either of the neighboring reference channels plus 1 dB. The full TIS results at the intermediate channels may be included as additional data and marked as supplemental in the test report.

Procedure for measuring relative sensitivity on intermediate channels (refer to [Figure 6-1](#)):

1. Move the EUT and chamber positioner(s) to the location & polarization resulting in the best-radiated free-space sensitivity measured for the closest, in frequency, fully measured channel (low, mid, high), now used as a Reference Channel.
2. Note the downlink power level which corresponds to the EUT's peak free-space radiated sensitivity as described in step 1 above, which will be referred to as FS EIS_(peak low). Next, determine the margin, M1_{low}, in dB, between the EUT's measured TIS and the corresponding TIS limit in Table 6-3. If the device doesn't meet the required TIS limit, then set M1_{low}=0. Adjust the digital call simulator to the RF power level calculated by the following formula:

EQUATION 6.7

$$\text{Downlink Signal Power}_{\text{low}} \text{ (dBm)} = \text{FS EIS}_{(\text{peak low})} \text{ (dBm)} + \text{M1}_{\text{low}} \text{ (dB)} + 3 \text{ (dB)}$$

For example, if the EUT's FS EIS_(peak low) was -108 dBm on the low-frequency reference channel, the EUT's low-frequency reference channel FS TIS_{low} was -104 dBm, and the FS TIS limit is -100 dBm, we have:

$$(-108 \text{ (dBm)} + 4 \text{ (dB)} + 3 \text{ (dB)}) \text{ dBm} = -101 \text{ dBm}$$

In this example, the signal generator would be set to -101 dBm for all intermediate channels associated with the low-frequency reference channel as shown in Figure 6-1. Similar evaluations are performed for mid and high reference channels. Note that M1_{low}, M1_{mid}, and M1_{high} can vary depending on how much the FS TIS of each channel exceeds the FS TIS limit.

3. Without changing the RF signal level at the EUT, change the frequency of the base station simulator such that it is operating on a defined intermediate channel.
4. Using the GPRS base station simulator, measure the downlink BLER using the required number of blocks as described above. The measured BLER must not exceed 10%.
5. Repeat steps 3 through 4 of this procedure for all remaining intermediate channels. If the reference channel changes from low to mid or high, move to the location and polarization of the next reference channel (mid, high), see step 1, and take the EUT's measured FS TIS and BHHR TIS on the low, mid and high-frequency reference channels into account when calculating the downlink signal power level according to Equation 6.7 in step 2.
6. Report the free-space pass/fail status of each intermediate channel listed in Appendix K.2 For both the full TIS test and the intermediate channel tests, free-space testing shall be conducted based on device type, as specified in Appendix O. Perform each test on all specified frequencies with the EUT antenna extended and retracted, as applicable.
7. If the device must be tested in the BHHR position, then move the EUT and chamber positioner(s) to the location and polarization resulting in the best-radiated BHHR sensitivity measured for the closest, in frequency, fully measured channel (low, mid, high), now used as a Reference Channel.
8. Devices which must be tested in the BHHR position shall be evaluated for intermediate channel performance using a Pass/Fail limit provided by the following formula:

EQUATION 6.8

$$\text{BHHR TIS Pass/Fail limit}_{\text{low}} \text{ (dBm)} = \text{FS TIS Pass/Fail limit (dBm)} + (\text{EUT BHHR TIS}_{\text{low}} \text{ (dBm)} - \text{EUT FS TIS}_{\text{low}} \text{ (dBm)})$$

For example, if the FS TIS limit is -100 dBm, the EUT BHHR TIS_{low} on the low-frequency reference channel is -99 dBm, and the EUT FS TIS_{low} on the low-frequency reference channel is -104 dBm, we have:

$$(-100 \text{ (dBm)} + (-99 \text{ (dBm)} - (-104 \text{ (dBm)})) \text{ dBm} = -95 \text{ dBm}$$

In this example, -95 dBm would be the BHR TIS Pass/Fail Limit_{low} used when repeating steps 1 through 6 above with the EUT in the BHR position for all intermediate channels associated with the low-frequency reference channel as shown in [Figure 6-1](#).

Similar evaluations are performed for mid and high reference channels. Note that BHR TIS Pass/Fail limit_{low}, BHR TIS Pass/Fail limit_{mid} and BHR TIS Pass/Fail limit_{high} can be different.

9. Note the downlink power level which corresponds to the EUT's peak BHR radiated sensitivity as described in step 7 above, which will be referred to as BHR EIS_(peak low). Since the BHR TIS Pass/Fail limit_{low} is directly derived from the FS limit and the TIS difference, see [Equation 6.8](#), the same margin M1_{low} is to be used. Adjust the digital call simulator to the RF power level calculated by the following formula:

EQUATION 6.9

$$\text{Downlink Signal Power}_{\text{low}} \text{ (dBm)} = \text{BHR EIS}_{\text{(peak low)}} \text{ (dBm)} + \text{M1}_{\text{low}} \text{ (dB)} + 3 \text{ (dB)}$$

For example, if the EUT's BHR EIS_(peak low) was -100 dBm on the low-frequency reference channel, the EUT's low-frequency reference channel BHR TIS low was -96 dBm, and the BHR TIS low limit is -92 dBm, we have:

$$(-100 \text{ (dBm)} + 4 \text{ (dB)} + 3 \text{ (dB)}) \text{ dBm} = -93 \text{ dBm}$$

In this example, the signal generator would be set to -93 dBm for all intermediate channels associated with the low-frequency reference channel as shown in [Figure 6-1](#). Similar evaluations are performed for mid and high reference channels.

10. Without changing the RF signal level, change the frequency of the base station simulator such that it is operating on a defined intermediate channel.
11. Using the GPRS base station simulator, measure the downlink BLER using the required number of blocks as described above. The measured BLER must not exceed 10%.
12. Repeat steps 10 through 11 of this procedure for all remaining intermediate channels. If the reference channel changes from low to mid or high, move to the location and polarization of the next reference channel (mid, high), see step 7, and take the EUT's measured FS TIS and BHR TIS on the low, mid and high-frequency reference channels into account when calculating the downlink signal power level according to [Equation 6.9](#) in step 9.
13. Report the BHR pass/fail status of each intermediate channel listed in [Appendix K.2](#). For both the full TIS test and the intermediate channel tests, head/hand testing shall be conducted based on device type, as specified in [Appendix O](#). Refer to [Appendix C](#) for head/hand testing requirements. Perform each test on all specified frequencies with the EUT antenna extended and retracted, as applicable.
14. The methodology in step 8 shall be applied to determine the TIS Pass/Fail Limits for all non-primary mechanical modes for the purpose of performing the intermediate channel desense test.

For the full TIS test, head/hand and/or free-space testing shall be conducted based on device type, as specified in [Appendix O](#). For the intermediate channel tests, head and hand phantom and free-space test configurations shall be conducted based on device type, as specified in [Appendix O](#). Refer to [Appendix C](#) for head/hand testing requirements. Perform each test on all specified frequencies with the EUT antenna extended and retracted, as applicable.

Note: Head-adjacent testing is only required for GPRS if the EUT supports usage against the head in this mode (e.g., VoIP).

6.5.2 Criteria

Results shall be reported as specified in [Appendix B](#) using the figures of merit given in [Appendix B.3](#). [Appendix B.1](#) contains the pass/fail OTA tables for GPRS. Reports shall include results for free-space and head/hand configurations (if applicable) across all channels measured with the EUT antenna extended and retracted.

The limits in [Table 6-3](#) are recommended. However, they shall be used to determine the mandatory pass/fail limits for the intermediate channel desense tests.

Relative sensitivity on intermediate channels test results shall be provided in a file format specified in [Appendix B.1](#). The reported RF level that produces a 10% BLER for each channel shall be less than the level determined in [Section 6.5.1](#).

TABLE 6-3 GPRS MAXIMUM C-TIS LEVEL (IN DBM) RECOMMENDED LIMITS FOR THE PRIMARY MECHANICAL MODE¹

Band	Device Held Up to Head for Voice (Yes/No)	Device Power Class	Device Width (mm) ²	FS	BHHL and BHR	HL and HR
GPRS 850	Yes ³	2	≤72	-99	TBD	TBD
		2	>72	-99	TBD	TBD
		3	≤72	-99	TBD	TBD
		3	>72	-99	TBD	TBD
		4	≤72	-99	TBD	TBD
		4	>72	-99	TBD	TBD
		5	≤72	-99	TBD	TBD
		5	>72	-99	TBD	TBD
	No ⁴	2	All	-99	N/A	N/A
		3	All	-99	N/A	N/A
		4	All	-99	N/A	N/A
		5	All	-99	N/A	N/A

TABLE 6-3 GPRS MAXIMUM C-TIS LEVEL (IN dBm) RECOMMENDED LIMITS FOR THE PRIMARY MECHANICAL MODE¹

Band	Device Held Up to Head for Voice (Yes/No)	Device Power Class	Device Width (mm) ²	FS	BHHL and BHHR	HL and HR
GPRS 1900	Yes ³	1	≤72	-101.5	TBD	TBD
		1	>72	-101.5	TBD	TBD
		2	≤72	-101.5	TBD	TBD
		2	>72	-101.5	TBD	TBD
		3	≤72	-101.5	TBD	TBD
		3	>72	-101.5	TBD	TBD
	No ⁴	1	All	-101.5	N/A	N/A
		2	All	-101.5	N/A	N/A
		3	All	-101.5	N/A	N/A

Note 1: Primary Mechanical Mode refers to device configured in preferred mode per manufacturer instructions (typically means antenna extended, fold or portrait slide open, but depends on form factor).
 Note 2: Differences between requirements for devices wider and narrower than 72 mm reflect observed differences in OTA performance with different hand phantoms of up to 6 dB.
 Note 3: "Yes" applies if the device supports voice operation in the talking position against the head in any cellular radio mode.
 Note 4: "No" would be applicable to data-centric devices that are not held up against the head, e.g., embedded laptop solutions.

6.6 EGPRS

6.6.1 Test Procedure

EGPRS Receiver Sensitivity measurements shall be performed using an EGPRS-capable Base Station Simulator to determine the EUT's receiver sensitivity by reporting the minimum forward-link power resulting in a Block Error Rate (BLER) of 10% or less with 95% confidence. Refer to [Appendix A](#) for set-up illustrations.

The set-up parameters defined in [Section 5.6](#) shall be used with the following exceptions:

- Forward-Link Power: As needed to maintain 0% BLER while using downlink modulation coding scheme MCS-5
- Power Control Level (PCL)/Gamma adjusted high enough to ensure that there are no communication errors introduced on the reverse channel. The EUT does not need to be set to maximum power at the initiation of the sensitivity search.
- The EGPRS base station simulator shall configure the EUT for EGPRS data loopback mode. Refer to 3GPP TS 05.05 and 3GPP TS 51.010-1 for procedures and criteria for the setup of loopback mode.
- The EGPRS base station simulator shall be configured to transmit with the maximum number of downlink slots supported by the EUT.

Note: If the test point is occurring in a significant null, the forward-link power may have to be raised to establish/maintain an active data loopback session.

For a device supporting multiple receivers, all receivers shall be enabled during the test procedure described in the remainder of this section. In this way, C-TIS is the test result, regardless whether the device supports one or multiple receivers. In the special case that I-TIS is the desired quantity of interest, the same procedure is followed, except that all but the specified receiver-under-test on the device are disabled.

Invoke data loopback between the EUT and the EGPRS base station simulator on one of the reference test channels. Verify that the EGPRS base station simulator is utilizing MCS-5 coding in the downlink. With an active data loopback session established, invoke a BLER Measurement.

Sensitivity measurements shall be equivalent to the minimum RF power level that results in a BLER of 10% or less with 95% confidence but may be limited to 2000 received blocks maximum at each measured location on the sphere. If the alternate/normalization method is not used, the number of blocks may be limited to 200 at each measured location on the sphere. The algorithms/methods used to arrive at these results can be optimized for speed by finding alternate points on the BLER curve as long as the data is eventually normalized to a value equivalent to 10% or less at each data point. The normalization value shall be determined in the same test configuration used to make the other BLER measurements (i.e., over-the-air, GSM set-up parameters, etc.) and shall be derived from an actual sensitivity measurement of 10% BLER or less with 95% confidence but may be limited to 2000 received blocks maximum and not based on an interpolation. In either case, the appropriate contribution to the measurement uncertainty shall be included. Refer to [Section 6.15.1](#) for details on this procedure and [Section 7.4](#) for details on this measurement uncertainty. The forward power step size shall be no more than 0.5 dB when the RF power level is near the target sensitivity level. The Power Control Level/Gamma setting shall be changed to maximum power when the final sensitivity measurement is made for each test point, as well as when any BLER reference curve is generated. The Forward Link Power, the Power Control Level/Gamma settings should be set back to defaults prior to tuning to the next test point. The minimum RF power level resulting in a BLER of 10% or less for each EUT test condition shall be recorded for integration pursuant to [Appendix B.3](#) to give a single figure of merit referred to as Total Isotropic Sensitivity (TIS).

Typically, the maximum deviation in RX level measurements from peak to null of any one channel does not exceed 30 dB. Therefore, the test facility may elect to initiate each sensitivity measurement starting with the base station power set 30 dB above the lowest sensitivity level measured in order to reduce the time required to search for the sensitivity floor. For points where this setting is below the target sensitivity level, the sensitivity may be considered negligible for that location and the initial value used in place of an actual measurement.

TIS shall be fully measured as described above and calculated pursuant to [Appendix B.3](#) for the 3 channels (low, middle and high) specified in [Section 5](#) for all frequency bands supported by the EUT and required to be tested per this test plan.

Relative sensitivity measurements or fully measured TIS will be repeated per channel on all channels. Reference channel and intermediate channel measurements shall be actual sensitivity measurements of 10% BLER or less with 95% confidence but may be limited to 2000 received blocks maximum.

When full TIS measurements are performed on intermediate channels, the intermediate channel passes if the full TIS result is better than 1) the TIS recommended limit or 2) the TIS result at either of the neighboring reference channels plus 1 dB. The full TIS results at the intermediate channels may be included as additional data and marked as supplemental in the test report.

Procedure for measuring relative sensitivity on intermediate channels (refer to [Figure 6-1](#)):

1. Move the EUT and chamber positioner(s) to the location & polarization resulting in the best-radiated free-space sensitivity measured for the closest, in frequency, fully measured channel (low, mid, high), now used as a Reference Channel.

2. Note the downlink power level which corresponds to the EUT's peak free-space radiated sensitivity as described in step 1 above, which will be referred to as FS EIS_(peak low). Next, determine the margin, M1_{low}, in dB, between the EUT's measured TIS and the corresponding TIS limit in Table 6-4. If the device doesn't meet the required TIS limit, then set M1_{low}=0. Adjust the digital call simulator to the RF power level calculated by the following formula:

EQUATION 6.10

$$\text{Downlink Signal Power}_{\text{low}} \text{ (dBm)} = \text{FS EIS}_{(\text{peak low})} \text{ (dBm)} + \text{M1}_{\text{low}} \text{ (dB)} + 3 \text{ (dB)}$$

For example, if the EUT's FS EIS_(peak low) was -108 dBm on the low-frequency reference channel, the EUT's low-frequency reference channel FS TIS_{low} was -104 dBm, and the FS TIS limit is -100 dBm, we have:

$$(-108 \text{ (dBm)} + 4 \text{ (dB)} + 3 \text{ (dB)}) \text{ dBm} = -101 \text{ dBm}$$

In this example, the signal generator would be set to -101 dBm for all intermediate channels associated with the low-frequency reference channel as shown in Figure 6-1. Similar evaluations are performed for mid and high reference channels. Note that M1_{low}, M1_{mid}, and M1_{high} can vary depending on how much the FS TIS of each channel exceeds the FS TIS limit.

3. Without changing the RF signal level at the EUT, change the frequency of the base station simulator such that it is operating on a defined intermediate channel.
4. Using the EGPRS base station simulator, measure the downlink BLER using the required number of blocks as described above. The measured BLER must not exceed 10%.
5. Repeat steps 3 through 4 of this procedure for all remaining intermediate channels. If the reference channel changes from low to mid or high, move to the location and polarization of the next reference channel (mid, high), see step 1, and take the EUT's measured FS TIS and BHHR TIS on the low, mid and high-frequency reference channels into account when calculating the downlink signal power level according to Equation 6.10 in step 2.
6. Report the free-space pass/fail status of each intermediate channel listed in Appendix K.2 For both the full TIS test and the intermediate channel tests, free-space testing shall be conducted based on device type, as specified in Appendix O. Perform each test on all specified frequencies with the EUT antenna extended and retracted, as applicable.
7. If the device must be tested in the BHHR position, then move the EUT and chamber positioner(s) to the location and polarization resulting in the best-radiated BHHR sensitivity measured for the closest, in frequency, fully measured channel (low, mid, high), now used as a Reference Channel.
8. Devices which must be tested in the BHHR position shall be evaluated for intermediate channel performance using a Pass/Fail limit provided by the following formula:

EQUATION 6.11

$$\text{BHHR TIS Pass/Fail limit}_{\text{low}} \text{ (dBm)} = \text{FS TIS Pass/Fail limit (dBm)} + (\text{EUT BHHR TIS}_{\text{low}} \text{ (dBm)} - \text{EUT FS TIS}_{\text{low}} \text{ (dBm)})$$

For example, if the FS TIS limit is -100 dBm, the EUT BHHR TIS_{low} on the low-frequency reference channel is -99 dBm, and the EUT FS TIS_{low} on the low-frequency reference channel is -104 dBm, we have:

$$(-100 \text{ (dBm)} + (-99 \text{ (dBm)} - (-104 \text{ (dBm)})) \text{ dBm} = -95 \text{ dBm}$$

In this example, -95 dBm would be the BHHR TIS Pass/Fail Limit_{low} used when repeating steps 1 through 6 above with the EUT in the BHHR position for all intermediate channels associated with the low-frequency reference channel as shown in Figure 6-1.

Similar evaluations are performed for mid and high reference channels. Note that BHR TIS Pass/Fail limit_{low}, BHR TIS Pass/Fail limit_{mid} and BHR TIS Pass/Fail limit_{high} can be different.

9. Note the downlink power level which corresponds to the EUT's peak BHR radiated sensitivity as described in step 7 above, which will be referred to as BHR EIS_(peak low). Since the BHR TIS Pass/Fail limit_{low} is directly derived from the FS limit and the TIS difference, see [Equation 6.11](#), the same margin M1_{low} is to be used. Adjust the digital call simulator to the RF power level calculated by the following formula:

EQUATION 6.12

$$\text{Downlink Signal Power}_{\text{low}} \text{ (dBm)} = \text{BHR EIS}_{\text{(peak low)}} \text{ (dBm)} + \text{M1}_{\text{low}} \text{ (dB)} + 3 \text{ (dB)}$$

For example, if the EUT's BHR EIS_(peak low) was -100 dBm on the low-frequency reference channel, the EUT's low-frequency reference channel BHR TIS low was -96 dBm, and the BHR TIS low limit is -92 dBm, we have:

$$(-100 \text{ (dBm)} + 4 \text{ (dB)} + 3 \text{ (dB)}) \text{ dBm} = -93 \text{ dBm}$$

In this example, the signal generator would be set to -93 dBm for all intermediate channels associated with the low-frequency reference channel as shown in [Figure 6-1](#). Similar evaluations are performed for mid and high reference channels.

10. Without changing the RF signal level, change the frequency of the base station simulator such that it is operating on a defined intermediate channel.
11. Using the EGPRS base station simulator, measure the downlink BLER using the required number of blocks as described above. The measured BLER must not exceed 10%.
12. Repeat steps 10 through 11 of this procedure for all remaining intermediate channels. If the reference channel changes from low to mid or high, move to the location and polarization of the next reference channel (mid, high), see step 7, and take the EUT's measured FS TIS and BHR TIS on the low, mid and high-frequency reference channels into account when calculating the downlink signal power level according to [Equation 6.12](#) in step 9.
13. Report the BHR pass/fail status of each intermediate channel listed in [Appendix K.2](#). For both the full TIS test and the intermediate channel tests, head/hand testing shall be conducted based on device type, as specified in [Appendix O](#). Refer to [Appendix C](#) for head/hand testing requirements. Perform each test on all specified frequencies with the EUT antenna extended and retracted, as applicable.
14. The methodology in step 8 shall be applied to determine the TIS Pass/Fail Limits for all non-primary mechanical modes for the purpose of performing the intermediate channel desense test.

For the full TIS test, head/hand and/or free-space testing shall be conducted based on device type, as specified in [Appendix O](#). For the intermediate channel tests, head and hand phantom and free-space test configurations shall be conducted based on device type, as specified in [Appendix O](#). Refer to [Appendix C](#) for head/hand testing requirements. Perform each test on all specified frequencies with the EUT antenna extended and retracted, as applicable.

Note: Head-adjacent testing is only required for EGPRS if the EUT supports usage against the head in this mode (e.g., VoIP).

6.6.2 Criteria

Results shall be reported as specified in [Appendix B](#) using the figures of merit given in [Appendix B.3](#). [Appendix B.1](#) contains the pass/fail OTA tables for EGPRS. Reports shall include results for free-space and head/hand configurations (if applicable) across all channels measured with the EUT antenna extended and retracted.

The limits in [Table 6-4](#) are recommended. However, they shall be used to determine the mandatory pass/fail limits for the intermediate channel desense tests.

Relative sensitivity on intermediate channels test results shall be provided in a file format specified in [Appendix B.1](#). The reported RF level that produces a 10% BLER for each channel shall be less than the level determined in [Section 6.6.1](#)

TABLE 6-4 EGPRS MAXIMUM C-TIS LEVEL (IN dBm) RECOMMENDED LIMITS FOR THE PRIMARY MECHANICAL MODE¹

Band	Device Held Up to Head for Voice (Yes/No)	Device Power Class	Device Width (mm) ²	FS	BHHL and BHHR	HL and HR
EGPRS 850	Yes ³	E1	≤72	-94	TBD	TBD
		E1	>72	-94	TBD	TBD
		E2	≤72	-94	TBD	TBD
		E2	>72	-94	TBD	TBD
		E3	≤72	-94	TBD	TBD
		E3	>72	-94	TBD	TBD
	No ⁴	E1	All	-94	N/A	N/A
		E2	All	-94	N/A	N/A
		E3	All	-94	N/A	N/A
EGPRS 1900	Yes ³	E1	≤72	-97	TBD	TBD
		E1	>72	-97	TBD	TBD
		E2	≤72	-97	TBD	TBD
		E2	>72	-97	TBD	TBD
		E3	≤72	-97	TBD	TBD
		E3	>72	-97	TBD	TBD
	No ⁴	E1	All	-97	N/A	N/A
		E2	All	-97	N/A	N/A
		E3	All	-97	N/A	N/A

Note 1: Primary Mechanical Mode refers to device configured in preferred mode per manufacturer instructions (typically means antenna extended, fold or portrait slide open, but depends on form factor).
 Note 2: Differences between requirements for devices wider and narrower than 72 mm reflect observed differences in OTA performance with different hand phantoms of up to 6 dB.
 Note 3: "Yes" applies if the device supports voice operation in the talking position against the head in any cellular radio mode.
 Note 4: "No" would be applicable to data-centric devices that are not held up against the head, e.g., embedded laptop solutions.

6.7 UMTS (WCDMA)

6.7.1 Test Procedure

Receiver Sensitivity measurements shall be performed using the Base Station Simulator to determine the EUT's receiver sensitivity by reporting the minimum forward-link power resulting in a Bit Error Rate (BER) of 1.2% or less at 12.2 kbps data rate with 95% confidence. Refer to [Appendix A](#) for set-up illustrations.

The set-up parameters defined in [Section 5.7](#) shall be used with the following exceptions:

- a. Forward-Link Power: As needed to maintain 0% BER at 12.2 kbps data rate
- b. Power Control: Algorithm 2, using closed loop power control with target power sufficient to guarantee error-free uplink transmission.
- c. All other parameters shall be set according to 3GPP TS 34.121-1 Reference Sensitivity Level test case.

Note: *If the test point is occurring in a significant null, the forward-link power may have to be raised to establish/maintain a call.*

For a device supporting multiple receivers, all receivers shall be enabled during the test procedure described in the remainder of this section. In this way, C-TIS is the test result, regardless whether the device supports one or multiple receivers. In the special case that I-TIS is the desired quantity of interest, the same procedure is followed, except that all but the specified receiver-under-test on the device are disabled.

Page the EUT and direct it to one of the reference test channels. With a digital voice/traffic channel established, invoke a BER Measurement.

Sensitivity measurements shall be equivalent to the minimum RF power level that results in a BER of 1.2% or less at 12.2 kbps data rate with 95% confidence but may be limited to 20,000 bits maximum at each measured location on the sphere. The algorithms/methods used to arrive at these results can be optimized for speed by finding alternate points on the BER curve and/or using higher data rates as long as the data is eventually normalized to a data set equivalent to 1.2% BER or less at each data point. Alternative points on the BER curve greater than 12% shall not be used. The normalization value shall be determined in the same test configuration used to make the other BER measurements (i.e., over-the-air, UMTS set-up parameters, etc.) and shall be derived from an actual sensitivity measurement of 1.2% BER or less at 12.2 kbps with 95% confidence but may be limited to 20,000 bits maximum and not an interpolation. The forward-link power step size shall be no more than 0.5dB when the RF power level is near the UMTS sensitivity level. The Power Control setting shall be changed to Algorithm 2 using all up-bits to guarantee that maximum power is transmitted when the final sensitivity measurement is made for each test point. The Forward-Link Power and the Power Control settings should be set back to defaults prior to tuning to the next test point. The minimum RF power level resulting in a BER of 1.2% or less for each EUT test condition shall be recorded for integration pursuant to [Appendix B.3](#) to give a single figure of merit referred to as Total Isotropic Sensitivity (TIS).

Typically, the maximum deviation in RX level measurements from peak to null of any one channel does not exceed 30 dB. Therefore, the test facility may elect to initiate each sensitivity measurement starting with the base station power set 30 dB above the lowest sensitivity level measured in order to reduce the time required to search for the sensitivity floor. For points where this setting is below the target sensitivity level, the sensitivity may be considered negligible for that location and the initial value used in place of an actual measurement.

TIS shall be fully measured as described above and calculated pursuant to [Appendix B.3](#) for the 3 channels (low, middle and high) specified in [Section 5](#) for all frequency bands supported by the EUT and required to be tested per this test plan.

Relative sensitivity measurements or fully measured TIS will be repeated per channel on a specified list of intermediate channels as shown in [Appendix K.3](#). The separation between channels is no greater than 2.5 MHz, and the intermediate channels are spaced off of the center channel.

When full TIS measurements are performed on intermediate channels, the intermediate channel passes if the full TIS result is better than 1) the TIS recommended limit or 2) the TIS result at either of the neighboring reference channels plus 1 dB. The full TIS results at the intermediate channels may be included as additional data and marked as supplemental in the test report.

Procedure for measuring relative sensitivity on intermediate channels (refer to [Figure 6-1](#)):

1. Move the EUT and chamber positioner(s) to the location & polarization resulting in the best-radiated free-space sensitivity measured for the closest, in frequency, fully measured channel (low, mid, high), now used as a Reference Channel.
2. Note the downlink power level which corresponds to the EUT's peak free-space radiated sensitivity as described in step 1 above, which will be referred to as FS EIS_(peak low). Next, determine the margin, M1_{low}, in dB, between the EUT's measured TIS and the corresponding TIS limit [Table 6-5](#). If the device doesn't meet the required TIS limit, then set M1_{low}=0. Adjust the digital call simulator to the RF power level calculated by the following formula:

EQUATION 6.13

$$\text{Downlink Signal Power}_{\text{low}} \text{ (dBm)} = \text{FS EIS}_{(\text{peak low})} \text{ (dBm)} + \text{M1}_{\text{low}} \text{ (dB)} + 3 \text{ (dB)}$$

For example, if the EUT's FS EIS_(peak low) was -108 dBm on the low-frequency reference channel, the EUT's low-frequency reference channel FS TIS_{low} was -104 dBm, and the FS TIS limit is -100 dBm, we have:

$$(-108 \text{ (dBm)} + 4 \text{ (dB)} + 3 \text{ (dB)}) \text{ dBm} = -101 \text{ dBm}$$

In this example, the signal generator would be set to -101 dBm for all intermediate channels associated with the low-frequency reference channel as shown in [Figure 6-1](#). Similar evaluations are performed for mid and high reference channels. Note that M1_{low}, M1_{mid}, and M1_{high} can vary depending on how much the FS TIS of each channel exceeds the FS TIS limit.

3. Without changing the RF signal level at the EUT, change the frequency of the base station simulator such that it is operating on a defined intermediate channel.
4. Using the UMTS base station simulator, measure the downlink BER at a 12.2 kbps data rate using the required number of bits as described above. The measured BER must not exceed 1.2%.
5. Repeat steps 3 through 4 of this procedure for all remaining intermediate channels. If the reference channel changes from low to mid or high, move to the location and polarization of the next reference channel (mid, high), see step 1, and take the EUT's measured FS TIS and BHR TIS on the low, mid and high-frequency reference channels into account when calculating the downlink signal power level according to [Equation 6.13](#) in step 2.
6. Report the free-space pass/fail status of each intermediate channel listed in [Appendix K.3](#). For both the full TIS test and the intermediate channel tests, free-space testing shall be conducted based on device type, as specified in [Appendix O](#). Perform each test on all specified frequencies with the EUT antenna extended and retracted, as applicable.

7. If the device must be tested in the BHR position, then move the EUT and chamber positioner(s) to the location and polarization resulting in the best-radiated BHR sensitivity measured for the closest, in frequency, fully measured channel (low, mid, high), now used as a Reference Channel.
8. Devices which must be tested in the BHR position shall be evaluated for intermediate channel performance using a Pass/Fail limit provided by the following formula:

EQUATION 6.14

$$\text{BHR TIS Pass/Fail limit}_{\text{low}} (\text{dBm}) = \text{FS TIS Pass/Fail limit} (\text{dBm}) + (\text{EUT BHR TIS}_{\text{low}} (\text{dBm}) - \text{EUT FS TIS}_{\text{low}} (\text{dBm}))$$

For example, if the FS TIS limit is -100 dBm, the EUT BHR TIS_{low} on the low-frequency reference channel is -99 dBm, and the EUT FS TIS_{low} on the low-frequency reference channel is -104 dBm, we have:

$$(-100 (\text{dBm}) + (-99 (\text{dBm}) - (-104 (\text{dBm}))) \text{ dBm} = -95 \text{ dBm}$$

In this example, -95 dBm would be the BHR TIS Pass/Fail Limit_{low} used when repeating steps 1 through 6 above with the EUT in the BHR position for all intermediate channels associated with the low-frequency reference channel as shown in [Figure 6-1](#).

Similar evaluations are performed for mid and high reference channels. Note that BHR TIS Pass/Fail limit_{low}, BHR TIS Pass/Fail limit_{mid} and BHR TIS Pass/Fail limit_{high} can be different.

9. Note the downlink power level which corresponds to the EUT's peak BHR radiated sensitivity as described in step 7 above, which will be referred to as BHR EIS_(peak low). Since the BHR TIS Pass/Fail limit_{low} is directly derived from the FS limit and the TIS difference, see [Equation 6.14](#), the same margin M1_{low} is to be used. Adjust the digital call simulator to the RF power level calculated by the following formula:

EQUATION 6.15

$$\text{Downlink Signal Power}_{\text{low}} (\text{dBm}) = \text{BHR EIS}_{(\text{peak low})} (\text{dBm}) + \text{M1}_{\text{low}} (\text{dB}) + 3 (\text{dB})$$

For example, if the EUT's BHR EIS_(peak low) was -100 dBm on the low-frequency reference channel, the EUT's low-frequency reference channel BHR TIS_{low} was -96 dBm, and the BHR TIS_{low} limit is -92 dBm, we have:

$$(-100 (\text{dBm}) + 4 (\text{dB}) + 3 (\text{dB})) \text{ dBm} = -93 \text{ dBm}$$

In this example, the signal generator would be set to -93 dBm for all intermediate channels associated with the low-frequency reference channel as shown in [Figure 6-1](#). Similar evaluations are performed for mid and high reference channels.

10. Without changing the RF signal level, change the frequency of the base station simulator such that it is operating on a defined intermediate channel.
11. Using the UMTS base station simulator, measure the downlink BER at a 12.2 kbps data rate using the required number of bits as described above. The measured BER must not exceed 1.2%.
12. Repeat steps 10 through 11 of this procedure for all remaining intermediate channels. If the reference channel changes from low to mid or high, move to the location and polarization of the next reference channel (mid, high), see step 7, and take the EUT's measured FS TIS and BHR TIS on the low, mid and high-frequency reference channels into account when calculating the downlink signal power level according to [Equation 6.15](#) in step 9.
13. Report the BHR pass/fail status of each intermediate channel listed in [Appendix K.3](#). For both the full TIS test and the intermediate channel tests, head/hand testing shall be

conducted based on device type, as specified in [Appendix O](#). Refer to [Appendix C](#) for head/hand testing requirements. Perform each test on all specified frequencies with the EUT antenna extended and retracted, as applicable.

14. The methodology in step 8 shall be applied to determine the TIS Pass/Fail Limits for all non-primary mechanical modes, if applicable, for the purpose of performing the intermediate channel desense test.

For the full TIS test and the intermediate channel tests, head/hand and/or free-space testing shall be conducted based on device type, as specified in [Appendix O](#). For the intermediate channel tests, head and hand phantom and free-space test configurations shall be conducted based on device type, as specified in [Appendix O](#). Refer to [Appendix C](#) for head/hand testing requirements. Perform each test on all specified frequencies with the EUT antenna extended and retracted, as applicable.

6.7.2 Criteria

Results shall be reported as specified in [Appendix B](#) using the figures of merit given in [Appendix B.3](#). [Appendix B.1](#) contains the pass/fail OTA tables for UMTS. Reports shall include results for free-space and head/hand configurations (if applicable) across all channels measured with the EUT antenna extended and retracted.

The limits in [Table 6-5](#) are recommended. However, they shall be used to determine the mandatory pass/fail limits for the intermediate channel desense tests.

Relative sensitivity on intermediate channels test results shall be provided in a file format equivalent to that specified in [Appendix B.1](#). The reported RF level that produces a 1.2% BER for each channel shall be less than the level determined in [Section 6.7.1](#).

TABLE 6-5 UMTS MAXIMUM C-TIS LEVEL (IN DBM) RECOMMENDED LIMITS FOR THE PRIMARY MECHANICAL MODE¹

Band	Device Held Up to Head for Voice (Yes/No)	Device Power Class	Device Width (mm) ²	FS	BHHL and BHHR	HL and HR
UMTS 850	Yes ³	3	≤72	-100	TBD	TBD
		3	>72	-100	TBD	TBD
		4	≤72	-100	TBD	TBD
		4	>72	-100	TBD	TBD
	No ⁴	3	All	-100	N/A	N/A
		4	All	-100	N/A	N/A
UMTS 1900	Yes ³	3	≤72	-102	TBD	TBD
		3	>72	-102	TBD	TBD
		4	≤72	-102	TBD	TBD
		4	>72	-102	TBD	TBD
	No ⁴	3	All	-102	N/A	N/A
		4	All	-102	N/A	N/A

TABLE 6-5 UMTS MAXIMUM C-TIS LEVEL (IN DBM) RECOMMENDED LIMITS FOR THE PRIMARY MECHANICAL MODE¹

Band	Device Held Up to Head for Voice (Yes/No)	Device Power Class	Device Width (mm) ²	FS	BHHL and BHHR	HL and HR
UMTS 2100/1700	Yes ³	3	≤72	-105	TBD	TBD
		3	>72	-105	TBD	TBD
		4	≤72	-105	TBD	TBD
		4	>72	-105	TBD	TBD
	No ⁴	3	All	-105	N/A	N/A
		4	All	-105	N/A	N/A

Note 1: Primary Mechanical Mode refers to device configured in preferred mode per manufacturer instructions (typically means antenna extended, fold or portrait slide open, but depends on form factor).
Note 2: Differences between requirements for devices wider and narrower than 72 mm reflect observed differences in OTA performance with different hand phantoms of up to 6 dB.
Note 3: "Yes" applies if the device supports voice operation in the talking position against the head in any cellular radio mode.
Note 4: "No" would be applicable to data-centric devices that are not held up against the head, e.g., embedded laptop solutions.

6.8 LTE

The TIS test procedure for LTE shall be performed using the procedure identified in [Section 6.8.1](#).

6.8.1 Test Procedure

Receiver sensitivity measurements shall be performed using data throughput as the measurement metric. The EUT's receiver sensitivity corresponds to the minimum downlink signal power required to provide a data throughput rate greater than or equal to 95% of the maximum throughput of the reference measurement channel. Refer to [Appendix A](#) for set-up illustrations.

For a device supporting multiple receivers, all receivers shall be enabled during the test procedure described in the remainder of this section. In this way, C-TIS is the test result, regardless whether the device supports one or multiple receivers. In the special case that I-TIS is the desired quantity of interest, the same procedure is followed, except that all but the specified receiver-under-test on the device are disabled.

The LTE system simulator and EUT shall be configured per section 7.3 (Reference Sensitivity Level) of 3GPP TS 36.521-1 using the defaults specified in 3GPP TS 36.521-1 and 3GPP TS 36.508 as applicable. As the 3GPP reference does not make any mention of p-Max, nor is p-Max included in the default message content defined in 3GPP TS 36.508, p-Max shall not be signaled during attach procedures or during measurements. For a given downlink RF power level, throughput shall be measured using the test procedure in section 7.3 of 3GPP TS 36.521-1 using the downlink and uplink reference measurement channels defined in Annexes A.2.2, A.2.3, and A.3.2 of 3GPP TS 36.521-1 and [Table 6-6](#). For LTE Band 13, the settings in [Table 6-7](#) shall take precedence over the settings in Annexes A.2.2, A.2.3, and A.3.2 of 3GPP TS 36.521-1. The LTE system simulator shall send continuous uplink power control "up" commands to the EUT to ensure the EUT's transmitter is at maximum output power during the sensitivity searches. The downlink power step size shall be no more than 0.5 dB when the RF

power level is near the LTE sensitivity level. The minimum RF power level resulting in a data throughput rate greater than or equal to 95% of the maximum throughput of the reference measurement channel shall be recorded as the downlink power level corresponding to the 95% throughput percentage (the data throughput rate is as defined in section 7.3 of 3GPP TS 36.521-1). Care must be taken to ensure that the duration of the throughput measurement is sufficient to achieve statistical significance according to Annex G.2 of 3GPP TS 36.521-1. The downlink signal level for each EUT test condition shall be recorded for integration pursuant to [Appendix B.3](#) to give a single figure of merit referred to as Total Isotropic Sensitivity (TIS).

Typically, the maximum deviation in receive level measurements from peak to null of any one channel does not exceed 30 dB. Therefore, the test facility may elect to initiate each sensitivity measurement starting with the base station power set 30 dB above the lowest sensitivity level measured in order to reduce the time required to search for the sensitivity floor. For points where this setting is below the target sensitivity level, the sensitivity may be considered negligible for that location and the initial value used in place of an actual measurement.

TIS shall be fully measured as described above and calculated pursuant to [Appendix B.3](#). TIS measurements shall be carried out for different frequency pairs (FDD; UL -uplink /DL -downlink) or frequencies (TDD) and RB allocations across the bands supported by the EUT, as defined in [Table 6-6](#). TIS results shall be based on total channel power.

TABLE 6-6 LTE TIS MEASUREMENTS TABLE FOR THE PRIMARY MECHANICAL MODE¹

Band	Channel Bandwidth (MHz)	Channel	RX Frequency (MHz) [center of DL RB allocation]	UL RB Allocation	DL RB Allocation
2 ²	10	650	1935	50 RB with RBstart=0	50 RB with RBstart=0
	10	900	1960	50 RB with RBstart=0	50 RB with RBstart=0
	10	1150	1985	50 RB with RBstart=0	50 RB with RBstart=0
4 ³	10	2000	2115	50 RB with RBstart=0	50 RB with RBstart=0
	10	2175	2132.5	50 RB with RBstart=0	50 RB with RBstart=0
	10	2350	2150	50 RB with RBstart=0	50 RB with RBstart=0
5 ⁴	10	2450	874	25 RB with RBstart=25	50 RB with RBstart=0
	10	2525	881.5	25 RB with RBstart=25	50 RB with RBstart=0
	10	2600	889	25 RB with RBstart=25	50 RB with RBstart=0
7	20	2850	2630	75 RB with RBstart=25	100 RB with RBstart=0
	20	3100	2655	75 RB with RBstart=25	100 RB with RBstart=0
	20	3350	2680	75 RB with RBstart=25	100 RB with RBstart=0
12 ⁵	5	5035	731.5	20 RB with RBstart=5	25 RB with RBstart=0
	5	5095	737.5	20 RB with RBstart=5	25 RB with RBstart=0
	5	5155	743.5	20 RB with RBstart=5	25 RB with RBstart=0
13	10	5230	751	15 RB with RBstart=0	50 RB with RBstart=0
14	10	5330	763	15 RB with RBstart=0	50 RB with RBstart=0
17 ⁵	10	5800	741	20 RB with RBstart=30	50 RB with RBstart=0

TABLE 6-6 LTE TIS MEASUREMENTS TABLE FOR THE PRIMARY MECHANICAL MODE¹

Band	Channel Bandwidth (MHz)	Channel	RX Frequency (MHz) [center of DL RB allocation]	UL RB Allocation	DL RB Allocation
25 ²	5	8065	1932.5	25 RB with RBstart=0	25 RB with RBstart=0
	5	8365	1962.5	25 RB with RBstart=0	25 RB with RBstart=0
	5	8665	1992.5	25 RB with RBstart=0	25 RB with RBstart=0
26 ⁴	5	8715	861.5	25 RB with RBstart=0	25 RB with RBstart=0
	5	8865	876.5	25 RB with RBstart=0	25 RB with RBstart=0
	5	9015	891.5	25 RB with RBstart=0	25 RB with RBstart=0
30	10	9820	2355	25 RB with RBstart=25	50 RB with RBstart=0
41	20	39750	2506	100RB with RBstart=0	100RB with RBstart=0
	20	40620	2593	100RB with RBstart=0	100RB with RBstart=0
	20	41490	2680	100RB with RBstart=0	100RB with RBstart=0
48	10	55290	3555	50 RB with RBstart=0	50 RB with RBstart=0
	10	55990	3625	50 RB with RBstart=0	50 RB with RBstart=0
	10	56690	3695	50 RB with RBstart=0	50 RB with RBstart=0
66 ³	10	66486	2115	50 RB with RBstart=0	50 RB with RBstart=0
	10	66786	2145	50 RB with RBstart=0	50 RB with RBstart=0
	10	67086	2175	50 RB with RBstart=0	50 RB with RBstart=0
70	15	68411	2002.5	75 RB with RBstart=0	75 RB with RBstart=0
71	10	68636	622	25 RB with RBstart=0	50 RB with RBstart=0
	10	68761	634.5	25 RB with RBstart=0	50 RB with RBstart=0
	10	68886	647	25 RB with RBstart=0	50 RB with RBstart=0

Note 1: Primary Mechanical Mode refers to device configured in preferred mode per manufacturer instructions (typically means antenna extended, fold or portrait slide open, but depends on form factor).

Note 2: If the device supports Band 25 and Band 2, then testing is only required to be completed in Band 25. The test requirements and data comparison between Bands 2 and 25 will not be directly comparable due to the usage of different RF channel bandwidths.

Note 3: If the device supports Band 4 and Band 66, then testing is only required to be completed in Band 66.

Note 4: If the device supports Band 26 and Band 5, then testing is only required to be completed in Band 26. The test requirements and data comparison between Bands 5 and 26 will not be directly comparable due to the usage of different RF channel bandwidths.

Note 5: If the device supports Band 12 and Band 17, then testing is only required to be completed in Band 12. The test requirements and data comparison between Bands 12 and 17 will not be directly comparable due to the usage of different RF channel bandwidths.

TABLE 6-7 UPLINK REFERENCE MEASUREMENT CHANNEL TABLE (UPLINK REFERENCE MEASUREMENT CHANNELS ARE PER ANNEXES A.2.2 AND A.2.3 OF 3GPP TS 36.521-1 WITH THE EXCEPTIONS NOTED IN THE TABLE FOR BAND 13)

Parameter	Unit	Value
Channel bandwidth	MHz	10
Allocated resource blocks		15

TABLE 6-7 UPLINK REFERENCE MEASUREMENT CHANNEL TABLE (UPLINK REFERENCE MEASUREMENT CHANNELS ARE PER ANNEXES A.2.2 AND A.2.3 OF 3GPP TS 36.521-1 WITH THE EXCEPTIONS NOTED IN THE TABLE FOR BAND 13)

Parameter	Unit	Value
DFT-OFDM Symbols per subframe		12
Modulation		QPSK
Target Coding rate		1/3
Payload size	Bits	1320
Transport block CRC	Bits	24
Number of code blocks - C		1
Code block CRC size	Bits	0
Total number of bits per sub-frame	Bits	4320
Total symbols per sub-frame		2160
UE Category		1-5

For the TIS test, head and hand phantom, hand phantom only and/or free-space testing shall be conducted based on device type, as specified in [Appendix O](#). Refer to [Appendix C](#) for head/hand testing requirements. Perform each test on all specified frequencies with the EUT antenna extended and retracted, as applicable.

Note: Head-adjacent testing is only required for LTE if the EUT supports usage against the head while utilizing an LTE airlink (e.g., VoIP).

Intermediate channel measurements shall performed for applicable bands as detailed in [Section 6.8.2](#).

6.8.2 LTE Intermediate Channel Measurements

Relative sensitivity measurements are not required in all bands. Bands for which intermediate channel measurements apply and the test frequencies to be used are specified in [Appendix K.4](#). Full TIS measurements may be substituted for relative sensitivity measurements.

Note: There are no LTE TIS limits defined. The following procedure is not applicable; see [Appendix O.10.1](#) for details.

When full TIS measurements are performed on intermediate channels, the intermediate channel passes if the full TIS result is better than 1) the TIS limit or 2) the TIS result at either of the neighboring reference channels plus 1 dB. The full TIS results at the intermediate channels may be included as additional data and marked as supplemental in the test report.

Procedure for measuring relative sensitivity on intermediate channels (refer [Figure 6-1](#)):

1. Move the EUT and chamber positioner(s) to the location & polarization resulting in the best-radiated free-space sensitivity measured for the closest, in frequency, fully measured channel (low, mid, high), now used as a Reference Channel.
2. Note the downlink power level which corresponds to the EUT's peak free-space radiated sensitivity as described in step 1 above, which will be referred to as FS EIS_(peak low). Next, determine the margin, M1_{low}, in dB, between the EUT's measured TIS and the corresponding

TIS limit in [Table 6-8](#). If the device doesn't meet the required TIS limit, then set $M1_{low}=0$. Adjust the digital call simulator to the RF power level calculated by the following formula:

EQUATION 6.16

$$\text{Downlink Signal Power}_{low} \text{ (dBm)} = \text{FS EIS}_{(\text{peak low})} \text{ (dBm)} + M1_{low} \text{ (dB)} + 3 \text{ (dB)}$$

For example, if the EUT's FS EIS_(peak low) was -108 dBm on the low-frequency reference channel, the EUT's low-frequency reference channel FS TIS_{low} was -104 dBm, and the FS TIS limit is -100 dBm, we have:

$$(-108 \text{ (dBm)} + 4 \text{ (dB)} + 3 \text{ (dB)}) \text{ dBm} = -101 \text{ dBm}$$

In this example, the signal generator would be set to -101 dBm for all intermediate channels associated with the low-frequency reference channel as shown in [Figure 6-1](#). Similar evaluations are performed for mid and high reference channels. Note that $M1_{low}$, $M1_{mid}$, and $M1_{high}$ can vary depending on how much the FS TIS of each channel exceeds the FS TIS limit.

3. Without changing the RF signal level at the EUT, change the frequency of the base station simulator such that it is operating on a defined intermediate channel.
4. Throughput of the EUT shall be measured using the test procedure in section 7.3 of 3GPP TS 36.521-1 using the downlink and uplink reference measurement channels defined in Annexes A.2.2, A.2.3, and A.3.2 of 3GPP TS 36.521-1 and Table 6-13 of this document (the data throughput rate is as defined in section 7.3 of 3GPP TS 36.521-1). The LTE system simulator shall send continuous uplink power control "up" commands to the EUT to ensure the EUT's transmitter is at maximum output power. The measured throughput rate shall be greater than or equal to 95% of the maximum throughput of the reference measurement channel. Care must be taken to ensure that the duration of the throughput measurement is sufficient to achieve statistical significance according to Annex G.2 of 3GPP TS 36.521-1.
5. Repeat steps 3 through 4 of this procedure for all remaining intermediate channels. If the reference channel changes from low to mid or high, move to the location and polarization of the next reference channel (mid, high), see step 1, and take the EUT's measured FS TIS and BHHR TIS on the low, mid and high-frequency reference channels into account when calculating the downlink signal power level according to [Equation 6.16](#) in step 2.
6. Report the free-space pass/fail status of each intermediate channel listed in [Appendix K.4](#) For both the full TIS test and the intermediate channel tests, free-space testing shall be conducted based on device type, as specified in [Appendix O](#). Perform each test on all specified frequencies with the EUT antenna extended and retracted, as applicable.
7. If the device must be tested in the BHHR position, then move the EUT and chamber positioner(s) to the location and polarization resulting in the best-radiated BHHR sensitivity measured for the closest, in frequency, fully measured channel (low, mid, high), now used as a Reference Channel.
8. Devices which must be tested in the BHHR position shall be evaluated for intermediate channel performance using a Pass/Fail limit provided by the following formula:

EQUATION 6.17

$$\text{BHHR TIS Pass/Fail limit}_{low} \text{ (dBm)} = \text{FS TIS Pass/Fail limit (dBm)} + (\text{EUT BHHR TIS}_{low} \text{ (dBm)} - \text{EUT FS TIS}_{low} \text{ (dBm)})$$

For example, if the FS TIS limit is -100 dBm, the EUT BHHR TIS_{low} on the low-frequency reference channel is -99 dBm, and the EUT FS TIS_{low} on the low-frequency reference channel is -104 dBm, we have:

$$(-100 \text{ (dBm)} + (-99 \text{ (dBm)} - (-104 \text{ (dBm)})) \text{ dBm} = -95 \text{ dBm}$$

In this example, -95 dBm would be the BHR TIS Pass/Fail Limit_{low} used when repeating steps 1 through 6 above with the EUT in the BHR position for all intermediate channels associated with the low-frequency reference channel as shown in [Figure 6-1](#).

Similar evaluations are performed for mid and high reference channels. Note that BHR TIS Pass/Fail limit_{low}, BHR TIS Pass/Fail limit_{mid} and BHR TIS Pass/Fail limit_{high} can be different.

9. Note the downlink power level which corresponds to the EUT's peak BHR radiated sensitivity as described in step 7 above, which will be referred to as BHR EIS_(peak low). Since the BHR TIS Pass/Fail limit_{low} is directly derived from the FS limit and the TIS difference, see [Equation 6.17](#), the same margin M1_{low} is to be used. Adjust the digital call simulator to the RF power level calculated by the following formula:

EQUATION 6.18

$$\text{Downlink Signal Power}_{\text{low}} \text{ (dBm)} = \text{BHR EIS}_{\text{(peak low)}} \text{ (dBm)} + \text{M1}_{\text{low}} \text{ (dB)} + 3 \text{ (dB)}$$

For example, if the EUT's BHR EIS_(peak low) was -100 dBm on the low-frequency reference channel, the EUT's low-frequency reference channel BHR TIS low was -96 dBm, and the BHR TIS low limit is -92 dBm, we have:

$$(-100 \text{ (dBm)} + 4 \text{ (dB)} + 3 \text{ (dB)}) \text{ dBm} = -93 \text{ dBm}$$

In this example, the signal generator would be set to -93 dBm for all intermediate channels associated with the low-frequency reference channel as shown in [Figure 6-1](#). Similar evaluations are performed for mid and high reference channels.

10. Without changing the RF signal level, change the frequency of the base station simulator such that it is operating on a defined intermediate channel.
11. Throughput of the EUT shall be measured using the test procedure in section 7.3 of 3GPP TS 36.521-1 using the downlink and uplink reference measurement channels defined in Annexes A.2.2, A.2.3, and A.3.2 of 3GPP TS 36.521-1 and Table 6-13 of this document (the data throughput rate is as defined in section 7.3 of 3GPP TS 36.521-1). The LTE system simulator shall send continuous uplink power control "up" commands to the EUT to ensure the EUT's transmitter is at maximum output power. The measured throughput rate shall be greater than or equal to 95% of the maximum throughput of the reference measurement channel. Care must be taken to ensure that the duration of the throughput measurement is sufficient to achieve statistical significance according to Annex G.2 of 3GPP TS 36.521-1.
12. Repeat steps 10 through 11 of this procedure for all remaining intermediate channels. If the reference channel changes from low to mid or high, move to the location and polarization of the next reference channel (mid, high), see step 7, and take the EUT's measured FS TIS and BHR TIS on the low, mid and high-frequency reference channels into account when calculating the downlink signal power level according to [Equation 6.18](#) in step 9.
13. Report the BHR pass/fail status of each intermediate channel listed in [Appendix K.4](#). For both the full TIS test and the intermediate channel tests, head/hand testing shall be conducted based on device type, as specified in [Appendix O](#). Refer to [Appendix C](#) for head/hand testing requirements. Perform each test on all specified frequencies with the EUT antenna extended and retracted, as applicable.
14. The methodology in step 8 shall be applied to determine the TIS Pass/Fail Limits for all non-primary mechanical modes, if applicable, for the purpose of performing the intermediate channel desense test.

For the intermediate channel tests, head and hand phantom and free-space test configurations shall be conducted based on device type, as specified in [Appendix O](#). Refer to [Appendix C](#) for head/hand testing requirements

Perform each test on all specified frequencies with the EUT antenna extended and retracted, as applicable.

Note: Head-adjacent testing is only required for LTE if the EUT supports usage against the head while utilizing an LTE airlink (e.g., VoIP).

6.8.3 Criteria

Results shall be reported as specified in [Appendix B](#) using the figures of merit given in [Appendix B.3](#). [Appendix B.1](#) contains the pass/fail OTA tables for LTE. Reports shall include results for applicable use cases, including free-space, head/hand configurations and/or wrist-worn configurations across all channels measured with the EUT antenna extended and retracted.

Relative sensitivity on intermediate channels test results shall be provided in a file format equivalent to that specified in [Appendix B.1](#).

The C-TIS value for each LTE band shall not exceed the values in [Table 6-8](#).

TABLE 6-8 LTE MAXIMUM C-TIS LEVEL (IN DBM) REQUIREMENTS FOR THE PRIMARY MECHANICAL MODE¹

Band	Use Cases Supported	Device Width (mm) ²	FS	WL and WR	BHHL and BHHR	HL and HR
LTE Band 71	Held to head for voice ³	≤72	TBD	N/A	TBD	TBD
		>72	TBD	N/A	TBD	TBD
	Wrist-worn ⁴	All	N/A	TBD	N/A	N/A
	Other ⁵	All	TBD	N/A	N/A	N/A
LTE Band 12	Held to head for voice ³	≤72	TBD	N/A	TBD	TBD
		>72	TBD	N/A	TBD	TBD
	Wrist-worn ⁴	All	N/A	TBD	N/A	N/A
	Other ⁵	All	TBD	N/A	N/A	N/A
LTE Band 17	Held to head for voice ³	≤72	TBD	N/A	TBD	TBD
		>72	TBD	N/A	TBD	TBD
	Wrist-worn ⁴	All	N/A	TBD	N/A	N/A
	Other ⁵	All	TBD	N/A	N/A	N/A
LTE Band 13	Held to head for voice ³	≤72	TBD	N/A	TBD	TBD
		>72	TBD	N/A	TBD	TBD
	Wrist-worn ⁴	All	N/A	TBD	N/A	N/A
	Other ⁵	All	TBD	N/A	N/A	N/A
LTE Band 14	Held to head for voice ³	≤72	TBD	N/A	TBD	TBD
		>72	TBD	N/A	TBD	TBD
	Wrist-worn ⁴	All	N/A	TBD	N/A	N/A
	Other ⁵	All	TBD	N/A	N/A	N/A

TABLE 6-8 LTE MAXIMUM C-TIS LEVEL (IN DBM) REQUIREMENTS FOR THE PRIMARY MECHANICAL MODE¹

Band	Use Cases Supported	Device Width (mm) ²	FS	WL and WR	BHHL and BHRH	HL and HR
LTE Band 26	Held to head for voice ³	≤72	TBD	N/A	TBD	TBD
		>72	TBD	N/A	TBD	TBD
	Wrist-worn ⁴	All	N/A	TBD	N/A	N/A
	Other ⁵	All	TBD	N/A	N/A	N/A
LTE Band 5	Held to head for voice ³	≤72	TBD	N/A	TBD	TBD
		>72	TBD	N/A	TBD	TBD
	Wrist-worn ⁴	All	N/A	TBD	N/A	N/A
	Other ⁵	All	TBD	N/A	N/A	N/A
LTE Band 70	Held to head for voice ³	≤72	TBD	N/A	TBD	TBD
		>72	TBD	N/A	TBD	TBD
	Wrist-worn ⁴	All	N/A	TBD	N/A	N/A
	Other ⁵	All	TBD	N/A	N/A	N/A
LTE Band 2	Held to head for voice ³	≤72	TBD	N/A	TBD	TBD
		>72	TBD	N/A	TBD	TBD
	Wrist-worn ⁴	All	N/A	TBD	N/A	N/A
	Other ⁵	All	TBD	N/A	N/A	N/A
LTE Band 25	Held to head for voice ³	≤72	TBD	N/A	TBD	TBD
		>72	TBD	N/A	TBD	TBD
	Wrist-worn ⁴	All	N/A	TBD	N/A	N/A
	Other ⁵	All	TBD	N/A	N/A	N/A
LTE Band 4	Held to head for voice ³	≤72	TBD	N/A	TBD	TBD
		>72	TBD	N/A	TBD	TBD
	Wrist-worn ⁴	All	N/A	TBD	N/A	N/A
	Other ⁵	All	TBD	N/A	N/A	N/A
LTE Band 66	Held to head for voice ³	≤72	TBD	N/A	TBD	TBD
		>72	TBD	N/A	TBD	TBD
	Wrist-worn ⁴	All	N/A	TBD	N/A	N/A
	Other ⁵	All	TBD	N/A	N/A	N/A
LTE Band 30	Held to head for voice ³	≤72	TBD	N/A	TBD	TBD
		>72	TBD	N/A	TBD	TBD
	Wrist-worn ⁴	All	N/A	TBD	N/A	N/A
	Other ⁵	All	TBD	N/A	N/A	N/A

TABLE 6-8 LTE MAXIMUM C-TIS LEVEL (IN DBM) REQUIREMENTS FOR THE PRIMARY MECHANICAL MODE¹

Band	Use Cases Supported	Device Width (mm) ²	FS	WL and WR	BHHL and BHHR	HL and HR
LTE Band 7	Held to head for voice ³	≤72	TBD	N/A	TBD	TBD
		>72	TBD	N/A	TBD	TBD
	Wrist-worn ⁴	All	N/A	TBD	N/A	N/A
	Other ⁵	All	TBD	N/A	N/A	N/A
LTE Band 41	Held to head for voice ³	≤72	TBD	N/A	TBD	TBD
		>72	TBD	N/A	TBD	TBD
	Wrist-worn ⁴	All	N/A	TBD	N/A	N/A
	Other ⁵	All	TBD	N/A	N/A	N/A
LTE Band 48	Held to head for voice ³	≤72	TBD	N/A	TBD	TBD
		>72	TBD	N/A	TBD	TBD
	Wrist-worn ⁴	All	N/A	TBD	N/A	N/A
	Other ⁵	All	TBD	N/A	N/A	N/A

Note 1: Primary Mechanical Mode refers to device configured in preferred mode per manufacturer instructions (typically means antenna extended, fold or portrait slide open, but depends on form factor).

Note 2: Differences between requirements for devices wider and narrower than 72 mm reflect observed differences in OTA performance with different hand phantoms of up to 6 dB.

Note 3: "Held to head for voice" applies if the device supports voice operation in the talking position against the head in any cellular radio mode.

Note 4: "Wrist-worn" would be applicable to devices that are worn on the wrist, e.g., smartwatches.

Note 5: "Other" would be applicable to data-centric devices that are not held up against the head nor Wrist-worn, e.g., embedded laptop solutions.

6.9 CDMA 1xEV-DO DATA

6.9.1 Test Procedure

Receiver Sensitivity measurements shall be performed using the Base Station Simulator to determine the EUT's receiver sensitivity by reporting the minimum forward-link power resulting in a Packet Error Rate (PER) of 0.5% or less with 95% confidence. Refer to [Appendix A](#) for set-up illustrations.

The set-up parameters defined in [Section 5.9](#) shall be used with the following exceptions:

- Forward-Link Power: As needed to maintain 0% PER.
- Power Control: Closed Loop.
- If the EUT supports 1xEV-DO Rev. A, then 1xEV-DO Rev. A shall be used for this test and the CDMA 1xEV-DO test parameters shall be set according to TIA-866-A paragraph 3.3.1 (subtype 2 physical layer) for the Receiver Sensitivity test and to the applicable

defaults specified in TIA-866-A section 8. If the EUT does not support 1xEV-DO Rev. A, then 1xEV-DO Rev. 0 shall be used for this test and the CDMA 1xEV-DO test parameters shall be set according to TIA-866-1 paragraph 3.1.1.3.1 for the Receiver Sensitivity test and to the applicable defaults specified in TIA-866-1 section 11.

Note: *If the test point is occurring in a significant null, the forward-link power may have to be raised to establish/maintain a call.*

For a device supporting multiple receivers, all receivers shall be enabled during the test procedure described in the remainder of this section. In this way, C-TIS is the test result, regardless whether the device supports one or multiple receivers. In the special case that I-TIS is the desired quantity of interest, the same procedure is followed, except that all but the specified receiver-under-test on the device are disabled.

Page the EUT and direct it to one of the reference test channels. With a digital voice/traffic channel established, invoke a PER Measurement.

Sensitivity measurements shall be equivalent to the minimum RF power level that results in a PER of 0.5% or less with 95% confidence at each measured location on the sphere. The algorithms/methods used to arrive at these results can be optimized for speed by finding alternate points on the PER curve as long as the data is eventually normalized to a data set equivalent to 0.5% or less at each data point. Alternative points on the PER curve greater than 2% shall not be used. The normalization value shall be determined in the same test configuration used to make the other PER measurements (i.e., over-the-air, CDMA set-up parameters, etc.) and shall be derived from an actual sensitivity measurement of 0.5% PER or less with 95% confidence and not an interpolation. In either case, the appropriate contribution to the measurement uncertainty shall be included. Refer to [Section 6.15.1](#) for details on this procedure and [Section 7.4](#) for details on this measurement uncertainty. The number of packets observed shall be consistent with a 95% confidence level but may be limited to 500 packets maximum at 2% PER and to 2000 packets maximum at 0.5% PER. For PER's in between these two points, the maximum number of packets shall be scaled proportionally. The forward-link power step size shall be no more than 0.5 dB when the RF power level is near the CDMA sensitivity level. The Power Control setting shall be changed to Always Up when the final sensitivity measurement is made for each test point. The Forward-Link Power and the Power Control settings should be set back to defaults prior to tuning to the next test point. The minimum RF power level resulting in a PER of 0.5% or less for each EUT test condition shall be recorded for integration pursuant to [Appendix B.3](#) to give a single figure of merit referred to as Total Isotropic Sensitivity (TIS).

Typically, the maximum deviation in RX level measurements from peak to null of any one channel does not exceed 30 dB. Therefore, the test facility may elect to initiate each sensitivity measurement starting with the base station power set 30 dB above the lowest sensitivity level measured in order to reduce the time required to search for the sensitivity floor. For points where this setting is below the target sensitivity level, the sensitivity may be considered negligible for that location and the initial value used in place of an actual measurement.

TIS shall be fully measured as described above and calculated pursuant to [Appendix B.3](#) for the three channels (low, middle and high) specified in [Section 5](#) for all frequency bands supported by the EUT and required to be tested per this test plan.

Relative sensitivity measurements or fully measured TIS shall be repeated per channel on a specified list of intermediate channels as shown in [Appendix K.1](#). The separation between channels is no greater than 500 kHz, and the intermediate channels are spaced off of the center channel.

When full TIS measurements are performed on intermediate channels, the intermediate channel passes if the full TIS result is better than 1) the TIS limit or 2) the TIS result at either of the neighboring reference

channels plus 1 dB. The full TIS results at the intermediate channels may be included as additional data and marked as supplemental in the test report.

Procedure for measuring relative sensitivity on intermediate channels (refer to [Figure 6-1](#)):

1. Move the EUT and chamber positioner(s) to the location & polarization resulting in the best-radiated free-space sensitivity measured for the closest, in frequency, fully measured channel (low, mid, high), now used as a Reference Channel.
2. Note the downlink power level which corresponds to the EUT's peak free-space radiated sensitivity as described in step 1 above, which will be referred to as FS EIS_(peak low). Next, determine the margin, M1_{low}, in dB, between the EUT's measured TIS and the corresponding TIS limit [Table 6-9](#). If the device doesn't meet the required TIS limit, then set M1_{low}=0. Adjust the digital call simulator to the RF power level calculated by the following formula:

EQUATION 6.19

$$\text{Downlink Signal Power}_{\text{low}} \text{ (dBm)} = \text{FS EIS}_{(\text{peak low})} \text{ (dBm)} + \text{M1}_{\text{low}} \text{ (dB)} + 3 \text{ (dB)}$$

For example, if the EUT's FS EIS_(peak low) was -108 dBm on the low-frequency reference channel, the EUT's low-frequency reference channel FS TIS_{low} was -104 dBm, and the FS TIS limit is -100 dBm, we have:

$$(-108 \text{ (dBm)} + 4 \text{ (dB)} + 3 \text{ (dB)}) \text{ dBm} = -101 \text{ dBm}$$

In this example, the signal generator would be set to -101 dBm for all intermediate channels associated with the low-frequency reference channel as shown in [Figure 6-1](#). Similar evaluations are performed for mid and high reference channels. Note that M1_{low}, M1_{mid}, and M1_{high} can vary depending on how much the FS TIS of each channel exceeds the FS TIS limit.

3. Without changing the RF signal level at the EUT, change the frequency of the base station simulator such that it is operating on a defined intermediate channel.
4. Using the base station simulator, measure the PER using the required number of packets as described above. The measured PER must not exceed 0.5%.
5. Repeat steps 3 through 4 of this procedure for all remaining intermediate channels. If the reference channel changes from low to mid or high, move to the location and polarization of the next reference channel (mid, high), see step 1, and take the EUT's measured FS TIS and BHR TIS on the low, mid and high-frequency reference channels into account when calculating the downlink signal power level according to [Equation 6.19](#) in step 2.
6. Report the free-space pass/fail status of each intermediate channel listed in [Appendix K.1](#) For both the full TIS test and the intermediate channel tests, free-space testing shall be conducted based on device type, as specified in [Appendix O](#). Perform each test on all specified frequencies with the EUT antenna extended and retracted, as applicable.
7. If the device must be tested in the BHR position, then move the EUT and chamber positioner(s) to the location and polarization resulting in the best-radiated BHR sensitivity measured for the closest, in frequency, fully measured channel (low, mid, high), now used as a Reference Channel.
8. Devices which must be tested in the BHR position shall be evaluated for intermediate channel performance using a Pass/Fail limit provided by the following formula:

EQUATION 6.20

$$\text{BHR TIS Pass/Fail limit}_{\text{low}} \text{ (dBm)} = \text{FS TIS Pass/Fail limit (dBm)} + (\text{EUT BHR TIS}_{\text{low}} \text{ (dBm)} - \text{EUT FS TIS}_{\text{low}} \text{ (dBm)})$$

For example, if the FS TIS limit is -100 dBm, the EUT BHR TIS_{low} on the low-frequency reference channel is -99 dBm, and the EUT FS TIS_{low} on the low-frequency reference channel is -104 dBm, we have:

$$(-100 \text{ (dBm)} + (-99 \text{ (dBm)} - (-104 \text{ (dBm)})) \text{ dBm} = -95 \text{ dBm}$$

In this example, -95 dBm would be the BHR TIS Pass/Fail Limit_{low} used when repeating steps 1 through 6 above with the EUT in the BHR position for all intermediate channels associated with the low-frequency reference channel as shown in [Figure 6-1](#).

Similar evaluations are performed for mid and high reference channels. Note that BHR TIS Pass/Fail limit_{low}, BHR TIS Pass/Fail limit_{mid} and BHR TIS Pass/Fail limit_{high} can be different.

9. Note the downlink power level which corresponds to the EUT's peak BHR radiated sensitivity as described in step 7 above, which will be referred to as BHR EIS_(peak low). Since the BHR TIS Pass/Fail limit_{low} is directly derived from the FS limit and the TIS difference, see [Equation 6.20](#), the same margin M1_{low} is to be used. Adjust the digital call simulator to the RF power level calculated by the following formula:

EQUATION 6.21

$$\text{Downlink Signal Power}_{\text{low}} \text{ (dBm)} = \text{BHR EIS}_{\text{(peak low)}} \text{ (dBm)} + \text{M1}_{\text{low}} \text{ (dB)} + 3 \text{ (dB)}$$

For example, if the EUT's BHR EIS_(peak low) was -100 dBm on the low-frequency reference channel, the EUT's low-frequency reference channel BHR TIS_{low} was -96 dBm, and the BHR TIS_{low} limit is -92 dBm, we have:

$$(-100 \text{ (dBm)} + 4 \text{ (dB)} + 3 \text{ (dB)}) \text{ dBm} = -93 \text{ dBm}$$

In this example, the signal generator would be set to -93 dBm for all intermediate channels associated with the low-frequency reference channel as shown in [Figure 6-1](#). Similar evaluations are performed for mid and high reference channels.

10. Without changing the RF signal level, change the frequency of the base station simulator such that it is operating on a defined intermediate channel.
11. Using the base station simulator, measure the PER using the required number of packets as described above. The measured PER must not exceed 0.5%.
12. Repeat steps 10 through 11 of this procedure for all remaining intermediate channels. If the reference channel changes from low to mid or high, move to the location and polarization of the next reference channel (mid, high), see step 7, and take the EUT's measured FS TIS and BHR TIS on the low, mid and high-frequency reference channels into account when calculating the downlink signal power level according to [Equation 6.21](#) in step 9.
13. Report the BHR pass/fail status of each intermediate channel listed in [Appendix K.1](#). For both the full TIS test and the intermediate channel tests, head/hand testing shall be conducted based on device type, as specified in [Appendix O](#). Refer to [Appendix C](#) for head/hand testing requirements. Perform each test on all specified frequencies with the EUT antenna extended and retracted, as applicable.
14. The methodology in step 8 shall be applied to determine the TIS Pass/Fail Limits for all non-primary mechanical modes, if applicable, for the purpose of performing the intermediate channel desense test.

For the full TIS test, head/hand and/or free-space testing shall be conducted based on device type, as specified in [Appendix O](#). For the intermediate channel tests, head and hand phantom and free-space test configurations shall be conducted based on device type, as specified in [Appendix O](#). Refer to [Appendix C](#) for head/hand testing requirements. Perform each test on all specified frequencies with the EUT antenna extended and retracted, as applicable.

Note: Head-adjacent testing is only required for CDMA 1xEV-DO data if the EUT supports usage against the head in this mode (e.g., VoIP).

6.9.2 Criteria

Results shall be reported as specified in [Appendix B](#) using the figures of merit given in [Appendix B.3](#). [Appendix B.1](#) contains the pass/fail OTA tables for CDMA 1xEV-DO. Reports shall include results for free-space and head/hand configurations (if applicable) across all channels measured with the EUT antenna extended and retracted.

Relative sensitivity on intermediate channels test results shall be provided in a file format equivalent to that specified in [Appendix B.1](#).

TABLE 6-9 CDMA 1xEV-DO DATA MAXIMUM C-TIS LEVEL (IN DBM) REQUIREMENTS FOR THE PRIMARY MECHANICAL MODE¹

Band	Device Held Up to Head for Voice (Yes/No)	Antenna Type	Device Width (mm) ²	FS	BHHL and BHR	HL and HR
CDMA 1xEV-DO DATA 800	Yes ³	Embedded	≤72	-102.5	TBD	TBD
		Embedded	>72	-102.5	TBD	TBD
		Stub or Retractable	≤72	-102.5	TBD	TBD
		Stub or Retractable	>72	-102.5	TBD	TBD
	No ⁴	All	All	-102.5	N/A	N/A
CDMA 1xEV-DO DATA 1900	Yes ³	Embedded	≤72	-102.5	TBD	TBD
		Embedded	>72	-102.5	TBD	TBD
		Stub or Retractable	≤72	-102.5	TBD	TBD
		Stub or Retractable	>72	-102.5	TBD	TBD
	No ⁴	All	All	-102.5	N/A	N/A
CDMA 1xEV-DO DATA 2100/1700	Yes ³	Embedded	≤72	-102.5	TBD	TBD
		Embedded	>72	-102.5	TBD	TBD
		Stub or Retractable	≤72	-102.5	TBD	TBD
		Stub or Retractable	>72	-102.5	TBD	TBD
	No ⁴	All	All	-102.5	N/A	N/A

Note 1: Primary Mechanical Mode refers to device configured in preferred mode per manufacturer instructions (typically means antenna extended, fold or portrait slide open, but depends on form factor).
 Note 2: Differences between requirements for devices wider and narrower than 72 mm reflect observed differences in OTA performance with different hand phantoms of up to 6 dB.
 Note 3: "Yes" applies if the device supports voice operation in the talking position against the head in any cellular radio mode.
 Note 4: "No" would be applicable to data-centric devices that are not held up against the head, e.g., embedded laptop solutions.

6.10 CDMA 1xRTT DATA

6.10.1 Test Procedure

Receiver Sensitivity measurements shall be performed using the Base Station Simulator to determine the EUT's receiver sensitivity by reporting the minimum forward-link power resulting in a Frame Error Rate (FER) of 0.5% or less with 95% confidence. Refer to [Appendix A](#) for set-up illustrations.

The set-up parameters defined in [Section 5.10](#) shall be used with the following exceptions:

- a. Forward-Link Power: As needed to maintain 0% FER
- b. Power Control: Closed Loop
- c. All other parameters shall be set according to TIA-98-E paragraph 3.5.1 for the Fundamental Channel Receiver Sensitivity test and to the defaults specified in TIA-98-E paragraph 6.5.2.

Note: *If the test point is occurring in a significant null, the forward-link power may have to be raised to establish/maintain a call.*

For a device supporting multiple receivers, all receivers shall be enabled during the test procedure described in the remainder of this section. In this way, C-TIS is the test result, regardless whether the device supports one or multiple receivers. In the special case that I-TIS is the desired quantity of interest, the same procedure is followed, except that all but the specified receiver-under-test on the device are disabled.

Page the EUT and direct it to one of the reference test channels. With a digital voice/traffic channel established, invoke an FER Measurement.

Sensitivity measurements shall be equivalent to the minimum RF power level that results in an FER of 0.5% or less with 95% confidence at each measured location on the sphere. The algorithms/methods used to arrive at these results can be optimized for speed by finding alternate points on the FER curve as long as the data is eventually normalized to a data set equivalent to 0.5% or less at each data point. Alternative points on the FER curve greater than 2% shall not be used. The normalization value shall be determined in the same test configuration used to make the other FER measurements (i.e. over-the-air, CDMA set-up parameters, etc.) and shall be derived from an actual sensitivity measurement of 0.5% FER or less with 95% confidence and not an interpolation. In either case, the appropriate contribution to the measurement uncertainty shall be included. Refer to [Section 6.15.1](#) for details on this procedure and [Section 7.4](#) for details on this measurement uncertainty. The number of frames observed shall be consistent with a 95% confidence level but may be limited to 500 frames maximum at 2% FER and to 2000 frames maximum at 0.5% FER. For FER's in between these two points, the maximum number of frames shall be scaled proportionally. The forward-link power step size shall be no more than 0.5dB when the RF power level is near the CDMA sensitivity level. The Power Control setting shall be changed to Always Up when the final sensitivity measurement is made for each test point. The Forward-Link Power and the Power Control settings should be set back to defaults prior to tuning to the next test point. The minimum RF power level resulting in an FER of 0.5% or less for each EUT test condition shall be recorded for integration pursuant to [Appendix B.3](#) to give a single figure of merit referred to as Total Isotropic Sensitivity (TIS).

Typically, the maximum deviation in RX level measurements from peak to null of any one channel does not exceed 30 dB. Therefore, the test facility may elect to initiate each sensitivity measurement starting with the base station power set 30 dB above the lowest sensitivity level measured in order to reduce the

time required to search for the sensitivity floor. For points where this setting is below the target sensitivity level, the sensitivity may be considered negligible for that location and the initial value used in place of an actual measurement.

TIS shall be fully measured as described above and calculated pursuant to [Appendix B.3](#) for the three channels (low, middle and high) specified in [Section 5](#) for all frequency bands supported by the EUT and required to be tested per this test plan.

Relative sensitivity measurements or fully measured TIS shall be repeated per channel on a specified list of intermediate channels as shown in [Appendix K.1](#). The separation between channels is no greater than 500 kHz, and the intermediate channels are spaced off of the center channel.

When full TIS measurements are performed on intermediate channels, the intermediate channel passes if the full TIS result is better than 1) the TIS limit or 2) the TIS result at either of the neighboring reference channels plus 1 dB. The full TIS results at the intermediate channels may be included as additional data and marked as supplemental in the test report.

Procedure for measuring relative sensitivity on intermediate channels (refer to [Figure 6-1](#)):

1. Move the EUT and chamber positioner(s) to the location & polarization resulting in the best-radiated free-space sensitivity measured for the closest, in frequency, fully measured channel (low, mid, high), now used as a Reference Channel.
2. Note the downlink power level which corresponds to the EUT's peak free-space radiated sensitivity as described in step 1 above, which will be referred to as FS EIS_(peak low). Next, determine the margin, M1_{low}, in dB, between the EUT's measured TIS and the corresponding TIS limit in [Table 6-8](#). If the device doesn't meet the required TIS limit, then set M1_{low}=0. Adjust the digital call simulator to the RF power level calculated by the following formula:

EQUATION 6.22

$$\text{Downlink Signal Power}_{\text{low}} \text{ (dBm)} = \text{FS EIS}_{(\text{peak low})} \text{ (dBm)} + \text{M1}_{\text{low}} \text{ (dB)} + 3 \text{ (dB)}$$

For example, if the EUT's FS EIS_(peak low) was -108 dBm on the low-frequency reference channel, the EUT's low-frequency reference channel FS TIS_{low} was -104 dBm, and the FS TIS limit is -100 dBm, we have:

$$(-108 \text{ (dBm)} + 4 \text{ (dB)} + 3 \text{ (dB)}) \text{ dBm} = -101 \text{ dBm}$$

In this example, the signal generator would be set to -101 dBm for all intermediate channels associated with the low-frequency reference channel as shown in [Figure 6-1](#). Similar evaluations are performed for mid and high reference channels. Note that M1_{low}, M1_{mid}, and M1_{high} can vary depending on how much the FS TIS of each channel exceeds the FS TIS limit.

3. Without changing the RF signal level at the EUT, change the frequency of the base station simulator such that it is operating on a defined intermediate channel.
4. Using the base station simulator, measure the FER using the required number of frames as described above. The measured FER must not exceed 0.5%.
5. Repeat steps 3 through 4 of this procedure for all remaining intermediate channels. If the reference channel changes from low to mid or high, move to the location and polarization of the next reference channel (mid, high), see step 1, and take the EUT's measured FS TIS and BHR TIS on the low, mid and high-frequency reference channels into account when calculating the downlink signal power level according to [Equation 6.22](#) in step 2.
6. Report the free-space pass/fail status of each intermediate channel listed in [Appendix K.1](#). For both the full TIS test and the intermediate channel tests, free-space testing shall be

conducted based on device type, as specified in [Appendix O](#). Perform each test on all specified frequencies with the EUT antenna extended and retracted, as applicable.

7. If the device must be tested in the BHHR position, then move the EUT and chamber positioner(s) to the location and polarization resulting in the best-radiated BHHR sensitivity measured for the closest, in frequency, fully measured channel (low, mid, high), now used as a Reference Channel.
8. Devices which must be tested in the BHHR position shall be evaluated for intermediate channel performance using a Pass/Fail limit provided by the following formula:

EQUATION 6.23

$$\text{BHHR TIS Pass/Fail limit}_{\text{low}} \text{ (dBm)} = \text{FS TIS Pass/Fail limit (dBm)} + (\text{EUT BHHR TIS}_{\text{low}} \text{ (dBm)} - \text{EUT FS TIS}_{\text{low}} \text{ (dBm)})$$

For example, if the FS TIS limit is -100 dBm, the EUT BHHR TIS_{low} on the low-frequency reference channel is -99 dBm, and the EUT FS TIS_{low} on the low-frequency reference channel is -104 dBm, we have:

$$(-100 \text{ (dBm)} + (-99 \text{ (dBm)} - (-104 \text{ (dBm)})) \text{ dBm} = -95 \text{ dBm}$$

In this example, -95 dBm would be the BHHR TIS Pass/Fail Limit_{low} used when repeating steps 1 through 6 above with the EUT in the BHHR position for all intermediate channels associated with the low-frequency reference channel as shown in [Figure 6-1](#).

Similar evaluations are performed for mid and high reference channels. Note that BHHR TIS Pass/Fail limit_{low}, BHHR TIS Pass/Fail limit_{mid} and BHHR TIS Pass/Fail limit_{high} can be different.

9. Note the downlink power level which corresponds to the EUT's peak BHHR radiated sensitivity as described in step 7 above, which will be referred to as BHHR EIS_(peak low). Since the BHHR TIS Pass/Fail limit_{low} is directly derived from the FS limit and the TIS difference, see [Equation 6.23](#), the same margin M1_{low} is to be used. Adjust the digital call simulator to the RF power level calculated by the following formula:

EQUATION 6.24

$$\text{Downlink Signal Power}_{\text{low}} \text{ (dBm)} = \text{BHHR EIS}_{\text{(peak low)}} \text{ (dBm)} + \text{M1}_{\text{low}} \text{ (dB)} + 3 \text{ (dB)}$$

For example, if the EUT's BHHR EIS_(peak low) was -100 dBm on the low-frequency reference channel, the EUT's low-frequency reference channel BHHR TIS_{low} was -96 dBm, and the BHHR TIS_{low} limit is -92 dBm, we have:

$$(-100 \text{ (dBm)} + 4 \text{ (dB)} + 3 \text{ (dB)}) \text{ dBm} = -93 \text{ dBm}$$

In this example, the signal generator would be set to -93 dBm for all intermediate channels associated with the low-frequency reference channel as shown in [Figure 6-1](#). Similar evaluations are performed for mid and high reference channels.

10. Without changing the RF signal level, change the frequency of the base station simulator such that it is operating on a defined intermediate channel.
11. Using the base station simulator, measure the FER using the required number of frames as described above. The measured FER must not exceed 0.5%.
12. Repeat steps 10 through 11 of this procedure for all remaining intermediate channels. If the reference channel changes from low to mid or high, move to the location and polarization of the next reference channel (mid, high), see step 7, and take the EUT's measured FS TIS and BHHR TIS on the low, mid and high-frequency reference channels into account when calculating the downlink signal power level according to [Equation 6.24](#) in step 9.

13. Report the BHHR pass/fail status of each intermediate channel listed in [Appendix K.1](#). For both the full TIS test and the intermediate channel tests, head/hand testing shall be conducted based on device type, as specified in [Appendix O](#). Refer to [Appendix C](#) for head/hand testing requirements. Perform each test on all specified frequencies with the EUT antenna extended and retracted, as applicable.
14. The methodology in step 8 shall be applied to determine the TIS Pass/Fail Limits for all non-primary mechanical modes, if applicable, for the purpose of performing the intermediate channel desense test.

For the full TIS test, head/hand and/or free-space testing shall be conducted based on device type, as specified in [Appendix O](#). For the intermediate channel tests, head and hand phantom and free-space test configurations shall be conducted based on device type, as specified in [Appendix O](#). Refer to [Appendix C](#) for head/hand testing requirements. Perform each test on all specified frequencies with the EUT antenna extended and retracted, as applicable.

Note: Head-adjacent testing is only required for CDMA 1xRTT data if the EUT supports usage against the head in this mode (e.g., VoIP).

6.10.2 Criteria

Results shall be reported as specified in [Appendix B](#) using the figures of merit given in [Appendix B.3](#). [Appendix B.1](#) contains the pass/fail OTA tables for CDMA 1xRTT DATA. Reports shall include results for free-space and head/hand configurations (if applicable) across all channels measured with the EUT antenna extended and retracted.

Relative sensitivity on intermediate channels test results shall be provided in a file format equivalent to that specified in [Appendix B.1](#).

TABLE 6-10 CDMA 1xRTT DATA MAXIMUM C-TIS LEVEL (IN DBM) REQUIREMENTS FOR THE PRIMARY MECHANICAL MODE¹

Band	Device Held Up to Head for Voice (Yes/No)	Antenna Type	Device Width (mm) ²	FS	BHHL and BHHR	HL and HR
CDMA 1xRTT DATA 800	Yes ³	Embedded	≤72	-101	TBD	TBD
		Embedded	>72	-101	TBD	TBD
		Stub or Retractable	≤72	-101	TBD	TBD
		Stub or Retractable	>72	-101	TBD	TBD
	No ⁴	All	All	-101	N/A	N/A
CDMA 1xRTT DATA 1900	Yes ³	Embedded	≤72	-101	TBD	TBD
		Embedded	>72	-101	TBD	TBD
		Stub or Retractable	≤72	-101	TBD	TBD
		Stub or Retractable	>72	-101	TBD	TBD
	No ⁴	All	All	-101	N/A	N/A

TABLE 6-10 CDMA 1xRTT DATA MAXIMUM C-TIS LEVEL (IN DBM) REQUIREMENTS FOR THE PRIMARY MECHANICAL MODE¹

Band	Device Held Up to Head for Voice (Yes/No)	Antenna Type	Device Width (mm) ²	FS	BHHL and BHHR	HL and HR
CDMA 1xRTT DATA 2100/1700	Yes ³	Embedded	≤72	-101	TBD	TBD
		Embedded	>72	-101	TBD	TBD
		Stub or Retractable	≤72	-101	TBD	TBD
		Stub or Retractable	>72	-101	TBD	TBD
	No ⁴	All	All	-101	N/A	N/A
<p>Note 1: Primary Mechanical Mode refers to device configured in preferred mode per manufacturer instructions (typically means antenna extended, fold or portrait slide open, but depends on form factor).</p> <p>Note 2: Differences between requirements for devices wider and narrower than 72 mm reflect observed differences in OTA performance with different hand phantoms of up to 6 dB.</p> <p>Note 3: "Yes" applies if the device supports voice operation in the talking position against the head in any cellular radio mode.</p> <p>Note 4: "No" would be applicable to data-centric devices that are not held up against the head, e.g., embedded laptop solutions.</p>						

6.11 CDMA with Receive Diversity

This section removed for V3.8.

6.12 UMTS Two-Branch Receive Diversity

This section removed for V3.8.

6.13 A-GNSS

6.13.1 Test Procedure

The procedure identified herein has been based on industry standards used during EUT conformance testing. However, some modifications were made to reduce test time, to reduce the Over-the-Air test solution complexity, and to account for specific Over-the-Air testing needs. The specific modifications are described in the corresponding cellular radio mode test specifics in [Section 6.13.5](#). It is assumed that the EUT will be tested per the conformance testing requirements defined by the industry standards. Therefore, any device that does not specifically meet the requirements of the industry standards would be identified during the conformance testing.

A-GNSS Receiver Sensitivity measurements shall be performed using test equipment that supports the relevant standards defined herein. Unless otherwise specified, the latest versions of the referenced 3GPP and/or 3GPP2 documents shall be used. The EUT's A-GNSS receiver sensitivity will be the minimum GNSS signal level that results in a passing result based on the relevant A-GNSS test parameters defined herein.

The test will determine the Total Isotropic Sensitivity (TIS), the Upper Hemisphere Isotropic Sensitivity (UHIS) (theta = 0 to 90 degrees) and the Partial Isotropic GNSS Sensitivity (PIGS) (theta = 0 to 120 degrees) of the GNSS receiver. The TIS test procedure based on receive signal strength specified in [Section 6.15.4](#) will be used.

The test applies to both UE-based and UE-assisted A-GNSS devices. If both UE-based and UE-assisted A-GNSS are supported by a device, then both modes will be tested unless otherwise specified.

This test will consist of the following measurements:

- Radiated 3D C/N_0 pattern measurement
- Radiated A-GNSS sensitivity measurement
- Radiated A-GNSS intermediate channel degradation measurement

TIS, UHIS, and PIGS shall be fully measured as described in [Section 6.13.2.1](#) and [Section 6.13.3.1](#), and calculated pursuant to Appendices [B.3.3](#), [B.3.5](#) and [B.3.6](#). Test the EUT in all frequency bands and cellular radio modes where the EUT supports A-GNSS and as defined herein (for example, A-GNSS Over-the-Air performance would not be tested for 1xEV-DO since it is only defined for CDMA). In all cases, the linearized C/N_0 values shall be used in the calculations.

For both the full TIS test and the A-GNSS intermediate channel degradation test, head with hand phantom and/or hand phantom testing shall be conducted based on device type, as specified in [Appendix O](#). Refer to [Appendix C](#) for head and hand testing requirements. Perform each test in all functional use configurations, and with the EUT antenna extended and retracted, as applicable.

A-GNSS OTA testing shall be performed with the device configured in its normal operating state with regards to the use of cellular diversity antennas.

When testing A-GNSS with different cellular radio modes used for assistance and with different operating bands, the Alternate Test Procedure for TIS Single Point Offset Test in [Section 6.15.1](#) may be used except that the position/polarization that is used shall be the same position/polarization determined for the A-GNSS sensitivity search. The Alternate Test Procedure for TIS Single Point Offset Test cannot be used when a different physical radiator, or different aperture tuning of the antenna is used between the reference cellular protocol/band and with the protocol/band being evaluated.

6.13.2 Radiated 3D C/N_0 Pattern Measurement

6.13.2.1 General

Devices supporting UE-assisted A-GNSS can perform this section, however devices supporting UE-based A-GNSS only may not be able to perform this section. If a device supports both methods, then the radiated 3D C/N_0 pattern measurement may be limited to UE-assisted A-GNSS. The 3D C/N_0 pattern will then be used for determining the radiated GNSS performance for both UE-assisted and UE-based A-GNSS. If a device only supports UE-based A-GNSS then the C/N_0 data shall be stored in the EUT's internal memory in the format specified in [Section 6.15.4.4.1](#). Another alternative for a device which only supports UE-based A-GNSS, is to enable UE-assisted A-GNSS or some other test mode to perform the radiated 3D C/N_0 pattern measurement. If used, the test mode shall allow for the exceptions in the device firmware for UE-based tests as specified in the cellular radio mode test specifics in [Section 6.13.5](#).

The pattern data shall be determined by averaging Carrier-to-Noise (C/N_0) measurement of all visible GNSS satellites for each measurement at each point on the sphere. The GNSS satellite simulator shall

provide the number of satellites specified herein and each satellite vehicle shall be at the same power. All C/N_0 measurements shall be done with the GNSS engine in a tracking mode or by using individual UE-assisted measurements. Orthogonal linear polarizations will be measured. For one measurement report, the reported satellite C/N_0 values shall be averaged. If it is necessary to obtain more measurements to reduce uncertainty, repeat the measurement requests at the same position and polarization and independently average the reported satellite C/N_0 values for each measurement report. After a sufficient number of measurement requests have been made, average the average results that were obtained for each measurement request. Sufficient averaging shall be completed to ensure that the uncertainty is less than the value included in the uncertainty budget. The C/N_0 pattern measurements shall be performed with any supported cellular radio mode using a low TX power to conserve battery power and to minimize self-interference. The transmit power shall be guaranteed to be 10 dB or more below the maximum TX power.

The C/N_0 pattern data shall be linearized per the linearization method specified in [Section 6.15.4.2](#).

Note that when the Alternate Test Procedure for TIS Single Point Offset Test can be and is used for A-GNSS testing, the 3D C/N_0 patterns do not need to be measured and the linearization step does not need to be applied for other applicable operating bands and cellular radio modes.

6.13.2.2 A-GPS L1

The radiated 3D C/N_0 pattern measurement shall be performed for A-GPS L1 (Assisted Global Positioning System). The GPS satellite simulator shall implement the GPS L1 scenarios as defined in the cellular radio mode test specifics in [Section 6.13.5](#). The A-GPS L1 test parameters shall be as defined in the cellular radio mode test specifics in [Section 6.13.5](#).

6.13.2.3 A-GLONASS

The radiated 3D C/N_0 pattern measurement does not have to be performed for A-GLONASS. Further evaluation of A-GLONASS performance will utilize the A-GPS L1 radiated 3D C/N_0 pattern measurement as determined in [Section 6.13.2.2](#).

6.13.3 Radiated A-GNSS Sensitivity Measurement

6.13.3.1 General

The radiated A-GNSS sensitivity search shall be performed at the position/polarization where the peak C/N_0 value was obtained in the upper hemisphere. The EUT's A-GNSS receiver sensitivity will be the minimum GNSS signal level that results in a passing result for the applicable A-GNSS Sensitivity test specified herein. The maximum A-GNSS sensitivity search step size shall be no more than 0.5 dB when the satellite vehicle power level is near the A-GNSS sensitivity level. The EUT shall be transmitting at maximum power at the declared A-GNSS sensitivity level. The transmit power settings for maximum power shall be as defined in the cellular radio mode test specifics in [Section 6.13.5](#). In order to minimize test time, the EUT measurements may be performed on a single call as long as each EUT measurement report is the result of a separate request. The EUT is not required to be power cycled in between measurements. When operating in UE-assisted, MS-Assisted, or UE-Based mode, the A-GNSS information shall be cleared in between measurements regardless of technology and operating mode. Refer to [Appendix A](#) for set-up illustrations.

The radiated sensitivity tests for a particular band/antenna configuration should be performed without disturbing the setup to minimize uncertainty in the sensitivity search. If the EUT will be disturbed during the test, a corresponding uncertainty component shall be included in the uncertainty budget.

The conducted A-GNSS sensitivity of the EUT shall also be measured at the antenna connector, if available. It is preferable that the EUT be the same as utilized for the TIS measurements. However, if the EUT does not readily support an antenna port for conducted measurements, a separate modified EUT may be provided for all conducted measurements. If no connector is available, the conducted sensitivity measurement is not required. Ideally, the sensitivity measurement will be performed with the same instrumentation in an equivalent configuration in order to minimize the measurement uncertainty involved. A different sensitivity measurement device may be used as long as any differences in absolute measurement accuracy are accounted for, either in corrections to the recorded sensitivity level or increased reported measurement uncertainty for the conducted measurement. Refer to [Appendix A.3](#) for more information on conducted sensitivity measurements and cabling setups.

6.13.3.2 A-GPS L1

The radiated A-GPS L1 sensitivity measurement shall be performed at the position/polarization where the peak C/N_0 value was obtained in the upper hemisphere. The GPS satellite simulator shall implement the GPS L1 scenarios as defined in the cellular radio mode test specifics in [Section 6.13.5](#). The A-GPS L1 test parameters shall be as defined in the cellular radio mode test specifics in [Section 6.13.5](#).

6.13.3.3 A-GLONASS

The radiated A-GLONASS sensitivity measurement shall be performed at the position/polarization where the peak C/N_0 value was obtained in the upper hemisphere during the radiated 3D C/N_0 pattern measurement for A-GPS L1 for one operating band in each cellular radio mode and in each usage mode (BHHR, BHHL, HR, and HL) using the Alternate Test Procedure for TIS Single Point Offset Test specified in [Section 6.15.1](#). However, the Alternate Test Procedure for TIS Single Point Offset Test cannot be used when a different physical radiator, or a different aperture tuning of the antenna is used between the reference cellular protocol/band and with the protocol/band being evaluated. In the case with dynamically tuned GNSS antennas as noted in [Section 6.13.1](#), the A-GLONASS sensitivity measurement as defined above shall be made in the same cellular radio mode and operating band as the full A-GPS L1 OTA sensitivity measurement and the alternative pass/fail test specified in the steps below shall not be used. The GLONASS satellite simulator shall implement the GLONASS scenarios as defined in the cellular radio mode test specifics in [Section 6.13.5](#). The A-GLONASS test parameters shall be as defined in the cellular radio mode test specifics in [Section 6.13.5](#).

For all other operating bands within the same cellular radio mode and usage mode (BHHR, BHHL, HR, and HL), the following steps shall be performed.

1. Ensure that the chamber positioner(s) are positioned at the location & polarization where the peak C/N_0 value was obtained in the upper hemisphere during the radiated 3D C/N_0 pattern measurement for A-GPS L1. If the positioners have been moved since the A-GPS L1 OTA sensitivity measurement, perform the A-GPS L1 sensitivity search immediately prior to the A-GLONASS sensitivity search.
2. Note the downlink power level which corresponds to the EUT's peak radiated A-GPS L1 sensitivity as described in step 1 above, which will be referred to as A-GPS L1 EIS_(peak, reference band). Note the downlink power level which corresponds to the EUT's peak radiated A-GLONASS sensitivity as described in step 1 above, which will be referred to as A-GLONASS EIS_(peak, reference band).

3. Change to the test frequency associated with the next operating band for the cellular radio mode in use and adjust the A-GLONASS signal level to the RF power level calculated by the following formula:

EQUATION 6.25

$$\begin{aligned} \text{A-GLONASS Signal Level (dBm)} &= \text{A-GPS L1 EIS}_{(\text{peak, band under test})} \text{ (dBm)} + \\ &\text{A-GLONASS EIS}_{(\text{peak, reference band})} \text{ (dBm)} - \text{A-GPS L1 EIS}_{(\text{peak, reference band})} + 3 \text{ (dB)} \end{aligned}$$

4. Perform the A-GLONASS sensitivity procedure as defined in the cellular radio mode test specifics in [Section 6.13.5](#) with the exception that pass/fail will be determined at only the A-GLONASS signal level calculated in step 3.
5. Repeat steps 3 and 4 for each remaining operating band for the cellular radio mode in use.
6. Repeat steps 1 through 5 for each remaining cellular radio mode in the existing usage mode.
7. Repeat steps 1 through 6 for each remaining usage mode (BHHR, BHHL, HR, and HL) based on device type, as specified in [Appendix O](#). Perform each test with the EUT antenna extended and retracted, as applicable.
8. Report the pass/fail status of each measurement taken in step 4 above.

6.13.4 Radiated A-GNSS Intermediate Channel Degradation Measurement

6.13.4.1 General

Devices supporting UE-assisted A-GNSS can perform this section, however devices supporting UE-based A-GNSS only may not be able to perform this section. If a device supports both methods, then the radiated A-GNSS intermediate channel degradation measurement will be limited to UE-assisted A-GNSS. In this case, the radiated A-GNSS intermediate channel degradation results will apply to both UE-assisted and UE-based A-GNSS. If a device only supports UE-based A-GNSS then the C/N_0 data shall be stored in the EUT's internal memory in the format specified in [Section 6.15.4.4.1](#). Another alternative for a device, which only supports UE-based A-GNSS, is to enable UE-assisted A-GNSS or some other test mode to perform the radiated A-GNSS intermediate channel degradation measurement. If used, the test mode shall allow for the exceptions in the device firmware for UE-based tests as specified in the cellular radio mode test specifics in [Section 6.13.5](#).

In addition to performing the sensitivity scan at the middle channel, the difference in sensitivity of the GNSS receiver will be evaluated with the cellular transceiver active for all intermediate cellular channels. This difference in sensitivity will be determined by measuring the difference in the radiated C/N_0 at the mid-channel and the radiated C/N_0 result at each of the intermediate channels with the cellular transmitter active at maximum power. This test will be called the A-GNSS intermediate channel degradation test.

For this test, the radiated C/N_0 shall be measured at the position/polarization where the peak C/N_0 was obtained in the upper hemisphere.

The C/N_0 measurements for each band/antenna configuration should be performed without disturbing the setup to minimize uncertainty in A-GNSS intermediate channel degradation test. If the EUT will be disturbed during the test, a corresponding uncertainty component shall be included in the uncertainty budget.

The basic test sequence for performing this A-GNSS intermediate channel degradation test is as follows:

1. Set up the satellite simulator with the number of satellites specified for the radiated 3D C/N_0 pattern measurement at the same power. The GNSS satellite power and scenario shall be set according to the recommendations in the cellular radio mode test specifics in [Section 6.13.5](#).
2. Enable a call using the appropriate cellular radio protocol.
3. Enable the GNSS engine.
4. Obtain a GNSS lock and start tracking.
5. Set the cellular radio channel to the middle channel and the transmit power level to maximum power as defined in the cellular radio mode test specifics in [Section 6.13.5](#).
6. Transmit the C/N_0 of the visible GNSS satellites over the existing cellular radio link. Record the average C/N_0 of the visible GNSS satellites. If additional C/N_0 measurements are required to minimize uncertainty, the measurements should be made prior to moving to the next step. Calculate the average C/N_0 (or average over repeated measurements of averages) and linearize the result using the data from the earlier linearization process. If a multi-GNSS scenario is being used, the C/N_0 measurements associated with each GNSS shall be considered separately. In the case where the pattern data is being re-used, only the satellite C/N_0 measurements for the GNSS associated with the pattern data shall be used when determining the corrections necessary as part of the linearization process.
7. Change the cellular radio channel to a channel listed in [Appendix K](#) as applicable for the corresponding cellular radio mode and operating band. It is up to the implementer to determine how to change channels.
8. Transmit the C/N_0 of the visible GNSS satellites over the existing cellular radio link. Record the average C/N_0 of the visible GNSS satellites. If additional C/N_0 measurements are required to minimize uncertainty, the measurements should be made prior to moving to the next step. Calculate the average C/N_0 (or average over repeated measurements of averages) and linearize the result using the data from the earlier linearization process. If a multi-GNSS scenario is being used, the C/N_0 measurements associated with each GNSS shall be considered separately. In the case where the pattern data is being re-used, only the satellite C/N_0 measurements for the GNSS associated with the pattern data shall be used when determining the corrections necessary as part of the linearization process.
9. Repeat steps 7 and 8 for each channel listed in [Appendix K](#) as applicable for the corresponding cellular radio mode and operating band.
10. Repeat steps 5 through 9 for each cellular radio mode and operating band supported by the EUT.

Alternatively, the C/N_0 measurements defined above may be achieved by using the methodology defined for the radiated 3D C/N_0 pattern measurement defined in [Section 6.13.2](#) except that transmit power level will be set to maximum power, as defined in the cellular radio mode test specifics in [Section 6.13.5](#).

The A-GNSS intermediate channel degradation is the difference between the linearized average C/N_0 (or average over repeated measurements of averages) with the transmitter at the mid-channel and the lowest linearized average C/N_0 (or average over repeated measurements of averages) with the transmitter at any intermediate channel (including the mid-channel). Therefore, the A-GNSS intermediate channel degradation will always be zero or greater. Report the A-GNSS intermediate channel degradation.

As specified above, the average Carrier-to-Noise (C/N_0) measurement of all visible GNSS satellites at each instance in time will be used. Sufficient averaging over time of C/N_0 measurements shall be completed to ensure that the uncertainty is less than the value specified in the lab's uncertainty budget.

$$A\text{-GNSS}_{ICD} = \text{A-GNSS degradation due to intermediate channel jamming}$$

$$CNR_{mid-channel} = \text{Linearized } C/N_0 \text{ with the mid-channel}$$

$$CNR_{min IC} = \text{minimum linearized } C/N_0 \text{ across all intermediate cellular channels}$$

$$A-GNSS_{ICD} = CNR_{mid-channel} - CNR_{min IC} \text{ (in dB)}$$

6.13.4.2 A-GPS L1

The radiated A-GPS L1 intermediate channel degradation measurement shall be performed at the position/polarization where the peak C/N_0 value was obtained in the upper hemisphere. The GPS satellite simulator shall implement the GPS L1 scenarios as defined in the cellular radio mode test specifics in [Section 6.13.5](#). The A-GPS L1 test parameters shall be as defined in the cellular radio mode test specifics in [Section 6.13.5](#).

6.13.4.3 A-GLONASS

The radiated A-GLONASS intermediate channel degradation measurement shall be performed at the position/polarization where the peak C/N_0 value was obtained in the upper hemisphere during the radiated 3D C/N_0 pattern measurement for A-GPS L1. The GNSS satellite simulator shall implement the multi-GNSS (A-GPS L1 and A-GLONASS) scenario as defined in the cellular radio mode test specifics in [Section 6.13.5](#). The multi-GNSS test parameters shall be as defined in the cellular radio mode test specifics in [Section 6.13.5](#). Since a multi-GNSS scenario is being used, the C/N_0 measurements associated with each GNSS shall be considered separately (A-GLONASS SVs need to be averaged separately from A-GPS L1 SVs). Since the pattern data is being re-used from GPS L1, only the satellite C/N_0 measurements for GPS L1 shall be used when determining the corrections necessary as part of the linearization process. The same offset determined by the linearization process shall be used to linearize the A-GLONASS results. The final A-GLONASS ICD result shall only include the measurements made on the A-GLONASS satellite vehicles.

6.13.5 Cellular Radio Mode Test Specifics

6.13.5.1 CDMA

6.13.5.1.1 A-GNSS Testing for CDMA: General

A-GNSS Receiver Sensitivity measurements shall be performed using test equipment that supports TIA-916 A-GPS L1 Accuracy and A-GPS L1 Sensitivity testing. In order to minimize test time, the EUT measurements may be performed on a single call as long as each EUT measurement report is the result of a separate request from the PDE (Position Determination Entity). In other words, the EUT would not be required to be power cycled and would not be required to have the A-GNSS information specifically cleared as per TIA-916 since the position capability utilized by the EUT during the test is MS-Assisted (Mobile Station Assisted). Refer to [Appendix A](#) for set-up illustrations.

The CDMA test channel for Cellular Band shall be channel 384. The CDMA test channel for PCS Band shall be channel 600. The CDMA test channel for AWS-1 Band shall be channel 450.

For the tests that operate at maximum output power, Closed-Loop Power Control shall be set to All Up bits.

For the tests that do not operate at maximum output power such as the radiated 3D C/N_0 pattern measurement, it is up to the implementer to set the Closed Loop Power Control such that the requirement specified can be met.

The radiated A-GNSS intermediate channel degradation measurements shall be made at the intermediate channels defined in [Appendix K.1](#).

6.13.5.1.2 A-GPS L1 Test Procedure for CDMA

For the A-GPS L1 radiated 3D C/N_0 pattern measurement and the A-GPS L1 intermediate channel degradation measurement, the C/N_0 measurements will be obtained from the TIA-916 A-GPS L1 accuracy test. The A-GPS L1 radiated 3D C/N_0 pattern measurements and the A-GPS L1 intermediate channel degradation measurements shall be performed with Radio Configuration 1, 2, or 3, Service Option 1, 2, 3, 17, or 55.

The A-GPS L1 radiated receiver sensitivity measurements shall utilize the TIA-916 sensitivity test with the exception that the C/N_0 Sigma 1 and Sigma 2 errors are ignored. The A-GPS L1 radiated receiver sensitivity measurements shall be performed with Radio Configuration 1 or 2, Service Option 3.

6.13.5.1.3 A-GLONASS Test Procedure for CDMA

A-GLONASS for CDMA is not required.

6.13.5.2 UMTS

6.13.5.2.1 A-GNSS Testing for UMTS: General

The following table specifies the mid-channel test channels for UMTS and the settings to be used when transmitting at the maximum UE output power.

TABLE 6-11 MAXIMUM TX POWER SETTINGS AND MID-CHANNEL TEST CHANNELS FOR UMTS

Band	Power setting	Test Channel
UMTS 850	All "up power" commands	TX: 4183, RX: 4408
UMTS 1900	All "up power" commands	TX: 9400, RX: 9800
UMTS 2100/1700	All "up power" commands	TX: 1413, RX: 1638

For the tests that do not operate at maximum UE output power such as the radiated 3D C/N_0 pattern measurement, it is up to the implementer to set the UE transmit power such that the requirement specified can be met.

The radiated A-GNSS intermediate channel degradation measurements shall be made at the intermediate channels defined in [Appendix K.3](#).

6.13.5.2.2 A-GPS L1 Test Procedure for UMTS

For the A-GPS L1 radiated 3D C/N_0 pattern measurement and the A-GPS L1 intermediate channel degradation measurement, the GPS L1 satellite simulator shall implement GPS L1 Scenario #1 as defined in Version 8.2.0 of 3GPP TS 34.108 Section 10.1.2.1. The scenario shall be reset before the initial satellites become not visible. The scenario shall be executed as required in Section 5.3 of Version 7.1.0 of 3GPP TS 34.171 except that random errors shall not be applied to the UE locations and the alternating locations requirement shall not be implemented. Early delivery of Acquisition Assistance Data and Reference Time Data may be provided to the EUT and a Voice Call or Supplemental Service Call shall be used for the wireless connection. The supplemental service call shall be in accordance with the defined 3GPP standards and shall support a circuit switched connection for normal device operation (3GPP test mode and/or data loopback calls are not allowed).

For a device which only supports UE-based A-GNSS and utilizes the test mode identified in [Section 6.13.2.1](#) and [Section 6.13.4.1](#), the test mode shall allow for the following exceptions in the device firmware for UE-based tests:

- Measurement Report Message (RRC): As referenced in TS 25.331 v8.2 Section 10.3.7.99, both “UE Positioning position estimate info” and “UE positioning GPS L1 measured results” IEs shall be included.

The A-GPS L1 radiated receiver sensitivity measurements shall be performed using the A-GPS L1 test parameters in [Table 6-12](#), which are based on version 7.1.0 of the 3GPP TS 34.171 test scenario 5.2.1.5 except for the modifications herein. This test scenario basically determines the A-GPS L1 sensitivity in acquisition mode with assistance using the control plane. GPS L1 assistance using control plane will be used for all A-GPS L1 TIS testing for UMTS.

TABLE 6-12 A-GPS L1 TEST PARAMETERS FOR UMTS

Test Parameter Description	Test Parameter Settings
Number of satellites	8
HDOP range	1.1 to 1.6
Propagation conditions	AWGN
GPS L1 time assistance	Coarse, ± 1.8 seconds
Phone response time	20 s
Acceptable response time to network	20.3 seconds
Success rate	95 successful fixes with the necessary accuracy out of 100 attempts (95%)
Position accuracy	101.3 m

Note that the satellite power levels for the sensitivity test are such that there will be one satellite, which transmits 5 dB higher than the other satellites. The reported sensitivity level will be based on the power of the weaker satellites. The 1 dB test tolerance or test parameter relaxation for the absolute GPS L1 signal level in Table F.4.1 of Version 7.1.0 of 3GPP TS 34.171 shall not be used in reporting the sensitivity measurement results. The above clarification means that passing the requirements of Version 7.1.0 of 3GPP TS 34.171, as modified in [Table 6-12](#) above, at signal levels -141 dBm and -146 dBm will lead to a sensitivity level report of -146 dBm, rather than -147 dBm.

For A-GPS L1 radiated receiver sensitivity measurements, the GPS L1 satellite simulator shall implement GPS L1 Scenario #1 as defined in Version 8.2.0 of 3GPP TS 34.108 Section 10.1.2.1. The scenario shall be reset before the viable running time expires as defined in the same clause. The scenario shall be executed as required in Section 5.2.1 of Version 7.1.0 of 3GPP TS 34.171 except that random errors shall not be applied to the UE locations and the alternating locations requirement shall not be implemented. Early delivery of Acquisition Assistance Data and Reference Time Data may be provided to the EUT and a Voice Call or Supplemental Service Call shall be used for the wireless connection. The supplemental service call shall be in accordance with the defined 3GPP standards and shall support a circuit switched connection for normal device operation (3GPP test mode and/or data loopback calls are not allowed).

6.13.5.2.3 A-GLONASS Test Procedure for UMTS

A-GLONASS OTA for UMTS is not required.

6.13.5.3 GSM

6.13.5.3.1 A-GNSS Testing for GSM: General

The following table specifies the mid-channel test channels for GSM and the settings to be used when transmitting at the maximum UE output power.

TABLE 6-13 MAXIMUM TX POWER SETTINGS AND MID-CHANNEL TEST CHANNELS FOR GSM

Protocol/Band	Power Setting	Test Channel
GSM 850	Select PCL from Table 5-6	190
GSM 1900	Select PCL from Table 5-7	661

For the tests that do not operate at maximum UE output power such as the radiated 3D C/N₀ pattern measurement, it is up to the implementer to set the UE transmit power such that the requirement specified can be met.

The radiated A-GNSS intermediate channel degradation measurements shall be made at the intermediate channels defined in [Appendix K.2](#).

6.13.5.3.2 A-GPS L1 Test Procedure for GSM

For the A-GPS L1 radiated 3D C/N_0 pattern measurement and the A-GPS L1 intermediate channel degradation measurement, the GPS L1 satellite simulator shall implement GPS L1 Scenario #1 as defined in Version 8.2.0 of 3GPP TS 34.108 Section 10.1.2.1. The scenario shall be reset before the initial satellites become not visible. The scenario shall be executed as required in Section 70.11.6 of Version 8.3.0 of 3GPP TS 51.010-1 except that random errors shall not be applied to the UE locations and the alternating locations requirement shall not be implemented. Early delivery of Acquisition Assistance Data and Reference Time Data may be provided to the EUT and a Voice Call or Supplemental Service Call shall be used for the wireless connection. The supplemental service call shall be in accordance with the defined 3GPP standards and shall support a circuit switched connection for normal device operation (3GPP test mode and/or data loopback calls are not allowed).

For a device which only supports UE-based A-GNSS and utilizes the test mode identified in [Section 6.13.2.1](#) and [Section 6.13.4.1](#), the test mode shall allow for the following exceptions in the device firmware for UE-based tests:

- Measure Position Response Message (RRLP): As referenced in TS 44.031 Section 4.2, both “locationInfo” and “gps-MeasureInfo” IEs shall be included.

The A-GPS L1 radiated receiver sensitivity measurements shall be performed using the A-GPS L1 test parameters in [Table 6-14](#), which are based on Version 8.3.0 of 3GPP TS 51.010-1 Test Scenario 70.11.5.1 for GSM, except for the modifications herein. This test scenario basically determines the A-GPS L1 sensitivity in acquisition mode with assistance using the control plane. GPS L1 assistance using control plane will be used for all A-GPS L1 TIS Testing for GSM.

TABLE 6-14 A-GPS L1 TEST PARAMETERS FOR GSM

Test Parameter Description	Test Parameter Settings
Number of satellites	8
HDOP range	1.1 to 1.6
Propagation conditions	AWGN
GPS L1 time assistance	Coarse, ± 1.8 seconds
Phone response time	16 s
Acceptable response time to network	20.3
Success rate	95 successful fixes with the necessary accuracy out of 100 attempts (95%)
Position accuracy	101.3 m

Note that the satellite power levels for the sensitivity test are such that there will be one satellite, which transmits 5 dB higher than the other satellites. The reported sensitivity level will be based on the power of the weaker satellites. The 1 dB test tolerance or test parameter relaxation for the absolute GPS L1 signal level in [Table 5.5.4.1](#) of Version 8.3.0 of 3GPP TS 51.010-1 shall not be used in reporting the sensitivity measurement results. The above clarification means that passing the requirements of Version 8.3.0 of 3GPP TS 51.010-1, as modified in [Table 6-14](#) above, at signal levels -141 dBm and -146 dBm will lead to a sensitivity level report of -146 dBm, rather than -147 dBm.

For A-GPS L1 radiated receiver sensitivity measurements, the GPS L1 satellite simulator shall implement GPS L1 Scenario #1 as defined in Version 8.2.0 of 3GPP TS 34.108 Section 10.1.2.1. The scenario shall be reset before the viable running time expires as defined in the same clause. The scenario shall be executed as required in Section 70.11.5.1 of Version 8.3.0 of 3GPP TS 51.010-1 except that random errors shall not be applied to the UE locations and the alternating locations requirement shall not be implemented. Early delivery of Acquisition Assistance Data and Reference Time Data may be provided to the EUT and a Voice Call or Supplemental Service Call shall be used for the wireless connection. The supplemental service call shall be in accordance with the defined 3GPP standards and shall support a circuit switched connection for normal device operation (3GPP test mode and/or data loopback calls are not allowed).

6.13.5.3.3 A-GLONASS Test Procedure for GSM

A-GLONASS OTA for GSM is not required.

6.13.5.4 LTE

6.13.5.4.1 LTE A-GNSS Testing: General

A-GNSS Receiver Sensitivity measurements shall be performed using test equipment that supports the relevant portions of 3GPP TS 37.571. Unless otherwise specified, the latest versions of the referenced 3GPP documents shall be used.

A-GNSS testing for LTE Devices will use either User Plane or Control Plane Positioning procedures. The use of User Plane positioning procedures is a deviation from A-GNSS for WCDMA/GSM/CDMA device testing which used Control Plane positioning procedures. Testing is only required in either User Plane or Control Plane and the positioning procedure used for test shall be selected by the manufacturer. The selection should be made with input from the target operators. In the absence of operator input, then User Plane Positioning procedures should be used.

When utilizing User Plane Positioning procedures, A-GNSS for LTE devices will be tested using the Open Mobile Alliance (OMA) Secure User Plane (SUPL) 2.0 protocol defined in OMA-AD-SUPL-V2_0-20110527-C. RRLP or LPP can be used as the underlying positioning protocol for SUPL 2.0 over the LTE default bearer.

When utilizing User Plane Positioning procedures, the test applies to LTE devices supporting either RRLP or LPP positioning protocol. The test requires that the device support SUPL 2.0 as the User Plane protocol. If the device supports both RRLP and LPP positioning protocols, either one of these could be used during the test. When utilizing User Plane Positioning procedures, the test only applies to UE-assisted A-GNSS procedures. UE-based A-GNSS testing is not required.

When utilizing Control Plane Positioning procedures, A-GNSS for LTE devices will be tested using the LPP positioning protocol necessary for testing the Control Plane based tests in 3GPP TS 37.571-1 over the LTE default bearer. When utilizing Control Plane Positioning procedures, the test applies to both UE-based and UE-assisted A-GNSS devices. If both UE-based and UE-assisted A-GNSS is supported by a device, then both modes will be tested.

The same positioning procedures and positioning protocol shall be used for the reference mode testing (A-GPS L1) and the additional GNSS mode testing (A-GLONASS, etc.).

Table 6-15 specifies the mid-channel test channels and UL and DL allocations for LTE except where specified herein.

TABLE 6-15 MID-BAND TEST CHANNEL SETTINGS FOR LTE

Band	Channel Bandwidth (MHz)	TX Channel	TX Frequency (MHz) [center of TX channel bandwidth] ¹	UL RB Allocation	RX Channel	RX Frequency (MHz) [center of RX channel bandwidth]	DL RB Allocation
2 ²	10	18900	1880	50 RB with RBstart=0	900	1960	50 RB with RBstart=0
4 ³	10	20175	1732.5	50 RB with RBstart=0	2175	2132.5	50 RB with RBstart=0
5 ⁴	10	20525	836.5	25 RB with RBstart=25	2525	881.5	50 RB with RBstart=0
7	20	21100	2535	75 RB with RBstart=25	3100	2655	100 RB with RBstart=0
12 ^{5,6}	5	23035	701.5	20 RB with RBstart=5	5035	731.5	25 RB with RBstart=0
12 ^{5,6}	5	23095	707.5	20 RB with RBstart=5	5095	737.5	25 RB with RBstart=0
13	10	23230	782	12 RB with RBstart=0	5230	751	50 RB with RBstart=0
14	10	23330	793	15 RB with RBstart=0	5330	763	50 RB with RBstart=0
17 ⁵	10	23790	710	20 RB with RBstart=30	5790	740	50 RB with RBstart=0
25 ²	5	26365	1882.5	25 RB with RBstart=0	8365	1962.5	25 RB with RBstart=0
26 ⁴	5	26865	831.5	25 RB with RBstart=0	8865	876.5	25 RB with RBstart=0
30	10	27710	2310	25 RB with RBstart=25	9820	2355	50 RB with RBstart=0
41	20	40620	2593	100 RB with RBstart=0	40620	2593	100 RB with RBstart=0
48	10	55990	3625	50 RB with RBstart=0	55990	3625	50 RB with RBstart=0
66 ³	10	132322	1745	50 RB with RBstart=0	66786	2145	50 RB with RBstart=0
70	15	133047	1702.41	75 RB with RBstart=0	68411	2002.5	75 RB with RBstart=0

TABLE 6-15 MID-BAND TEST CHANNEL SETTINGS FOR LTE

Band	Channel Bandwidth (MHz)	TX Channel	TX Frequency (MHz) [center of TX channel bandwidth] ¹	UL RB Allocation	RX Channel	RX Frequency (MHz) [center of RX channel bandwidth]	DL RB Allocation
71	10	133297	680.5	25 RB with Rbstart=0	68761	634.5	50 RB with RBstart=0
<p>Note 1: The frequencies listed in this table are the center of the channel bandwidth and not the center of the RB allocation.</p> <p>Note 2: If the device supports Band 25 and Band 2, then testing is only required to be completed in Band 25.</p> <p>Note 3: If the device supports Band 4 and Band 66, then testing is only required to be completed in Band 66.</p> <p>Note 4: If the device supports Band 26 and Band 5, then testing is only required to be completed in Band 26.</p> <p>Note 5: If the device supports Band 12 and Band 17, then testing is only required to be completed in Band 12.</p> <p>Note 6: Testing is only required on either the low or mid channel in Band 12, and the test channel shall be selected by the manufacturer. The selection should be made with input from the target operators. In the absence of operator input, then the mid channel should be used. When the low channel is used, the GPS L1 intermediate channel degradation tests are required for the remaining channels in Table K-7. If testing is done for both low and mid channels, then the GPS L1 intermediate channel degradation test is only required for the remaining channels in Table K-7.</p>							

For the tests that operate at maximum output power, the UE transmit power shall be set to the maximum by sending continuous uplink power control “up” commands in every uplink scheduling information to the UE and allowing at least 200ms for the UE to reach its maximum level. As the 3GPP reference does not make any mention of p-Max, nor is p-Max included in the default message content defined in 3GPP TS 36.508, p-Max shall not be signaled during attach procedures or during measurements.

For the tests that do not operate at maximum output power such as the radiated 3D C/N₀ pattern measurement, it is up to the implementer to utilize UE power control such that the requirement specified can be met.

The radiated A-GNSS intermediate channel degradation measurements shall be made at the intermediate channels defined in [Appendix K.4](#).

Note: Head-adjacent testing is only required for LTE if the EUT supports usage against the head in this mode (e.g., VoIP).

6.13.5.4.2 A-GPS L1 Test Procedure for LTE

For the A-GPS L1 radiated 3D C/N₀ pattern measurement and the A-GPS L1 intermediate channel degradation measurement, the GPS L1 satellite simulator shall implement GNSS Scenario #1 as defined in 3GPP TS 37.571-5 Section 6.2.1.2.1 for satellites simulated for 3GPP TS 37.571-1 subclause 7, sub-test 1. The scenario shall be reset before the initial satellites become not visible. The scenario shall be executed as required in Section 7.2 Sub-Test Number 1 of 3GPP TS 37.571-1 except that random errors shall not be applied to the UE locations and the alternating locations requirement shall not be implemented. Early delivery of Acquisition Assistance Data and Reference Time Data may be provided to the EUT and the default EPS bearer shall be used for the wireless connection to establish the SUPL 2.0 or Control Plane session.

For a device which only supports UE-based A-GPS L1 and utilizes the test mode identified in [Section 6.13.2.1](#) and [Section 6.13.4.1](#), the test mode shall allow for the following exceptions in the device firmware for UE-based tests:

- Provide Location Information (LPP): In the A-GNSS-ProvideLocationInformation IE of the LPP Provide Location Information message as referenced in TS 36.355 Section 6.5.2.5, both “gnss-SignalMeasurementInformation” and “gnss-LocationInformation” shall be included.

The A-GPS L1 radiated receiver sensitivity measurements will be performed for the LTE bands, channel numbers, and the allocations specified in Table 6-15 with the following exceptions. For LTE Band 13, the device shall be tested with an UL RB allocation of 12 RBs with an RBstart of 38 and with an UL RB allocation of 1 RB with an RBstart of 49 as opposed to the UL allocation specified in Table 6-15. For LTE Band 14, the device shall be tested with an UL RB allocation of 12 RBs with an RBstart of 0 and with an UL RB allocation of 1 RB with an RBstart of 0 as opposed to the UL allocation specified in Table 6-15. If the device supports Band 25 and Band 2, then testing is only required to be completed in Band 25. If the device supports Band 26 and Band 5, then testing is only required to be completed in Band 26. If the device supports Band 12 and Band 17, then testing is only required to be completed in Band 12. If the device supports Band 4 and Band 66, then testing is only required to be completed in Band 66. For devices that support transmitter antenna switching, the sensitivity search in Band 13 and Band 14 and the calculation of TIS, UHIS, and PIGS shall be performed with the transmitter connected to each transmit antenna independently. TIS, UHIS, and PIGS results shall be provided for both transmit antennas. Results shall pass for both transmit antennas or the test for Band 13/Band 14 shall be failed.

When submitting a device for LTE A-GPS L1 testing, the device manufacturer shall include a declaration statement that identifies one of the following options to define the testing to be performed by the test lab:

Option 1: LTE A-GPS L1 testing is performed without the presence of SIB8 and SIB16 for all LTE bands.

Option 2: LTE A-GPS L1 testing is performed using the logic below:

- 1>If the device supports SIB8 or SIB16 for A-GPS L1 demodulation performance:
 - 2>If the device supports both SIB8 and SIB16 for A-GPS L1 demodulation performance:
 - 3>If the device supports both LTE and CDMA:
 - 4>Execute testing in all bands using SIB8.
 - 3>Else (i.e. the device is LTE only or the device supports only LTE and legacy 3GPP modes):
 - 4>Execute testing in all bands using SIB16.
 - 2>Else:
 - 3>If the device supports SIB8 only:
 - 4>Execute testing in all bands using SIB8.
 - 3>If the device supports SIB16 only:
 - 4>Execute testing in all bands using SIB16.
 - 1>Else
 - 2>Execute testing in all bands without SIB8 or SIB16 present.

Option 3: LTE A-GPS L1 testing is performed without the presence of SIB8 and SIB16 for all LTE bands. For a subset of LTE bands selected by the device manufacturer, the sensitivity search and

TIS/UHIS/PIGS calculations are repeated with SIB8 and/or SIB16 in accordance with the logic in Option 2. The selection of LTE bands for SIB8 and SIB16 testing should be made with input from the target operators.

Radiated Sensitivity Measurement without SIB8/SIB16:

The A-GPS L1 radiated receiver sensitivity measurements shall be performed using the A-GPS L1 test parameters in [Table 6-16](#), which are based on 3GPP TS 37.571-1 Test Scenario 7.1.1 Sub-Test Number 1 except for modifications herein.

TABLE 6-16 A-GPS L1 TEST PARAMETERS FOR LTE

Test Parameter Description	Test Parameter Settings
Number of satellites	8
HDOP range	1.1 to 1.6
Propagation conditions	AWGN
GPS L1 time assistance	Coarse, ± 2 s
Phone response time	20 seconds for LPP 16 seconds for RRLP
Acceptable response time to network	20.3 seconds
Success rate	95 successful fixes with the necessary accuracy out of 100 attempts (95%)
Position accuracy	101.3 m

Note that the satellite power levels for the sensitivity test are such that there will be one satellite, which transmits 5 dB higher than the other satellites. The reported sensitivity level will be based on the power of the weaker satellites. The 1 dB test tolerance or test parameter relaxation for the absolute GPS L1 signal level in C.2.1 in 3GPP TS 37.571-1 shall not be used in reporting the sensitivity measurement results. The above clarification means that, at signal levels -141 dBm and -146 dBm will lead to a sensitivity level report of -146 dBm, rather than -147 dBm. For Control Plane testing, the GPS L1 engine shall be cold started for every location attempt.

For A-GPS L1 radiated receiver sensitivity measurements, the GPS L1 satellite simulator shall implement GNSS Scenario #1 as defined in 3GPP TS 37.571-5 Section 6.2.1.2.1 for satellites simulated for 3GPP TS 37.571-1 subclause 7, sub-test 1. The scenario shall be reset before the viable running time expires as defined in the same clause. The scenario shall be executed as required in Section 7.1.1 Sub-Test Number 1 of 3GPP TS 37.571-1 except that random errors shall not be applied to the UE locations and the alternating locations requirement shall not be implemented. Early delivery of Acquisition Assistance Data and Reference Time Data may be provided to the EUT and the SUPL 2.0 or Control Plane Positioning session shall be used over the wireless data connection.

Radiated Sensitivity Measurement with SIB8/SIB16:

The A-GPS L1 radiated receiver sensitivity measurements shall be performed using the A-GPS L1 test parameters in [Table 6-16](#), which are based on 3GPP TS 37.571-1 Test Scenario 7.1.1 Sub-Test Number 1, and with the exceptions below:

1. All satellite power levels shall be set to the same power level.
2. The network emulator shall broadcast SIB8 (including the fields and settings shown below) or SIB16 (including all mandatory and optional fields). UTC Time in SIB16 and CDMA system time in SIB8 shall be synchronized to within +/- 100ns of GPS L1 time.

```

sib8 :
    {
        systemTimeInfo
        {
            cdma-EUTRA-Synchronisation TRUE,
            cdma-SystemTime synchronousSystemTime : 'xxxxxxxx
                xxxxxxxx xxxxxxxx xxxxxxxx xxxxxxxx'
        },
        searchWindowSize 8,
        parameters1XRTT
        {
        },
        csfb-SupportForDualRxUEs-r9 TRUE
    }

```

All satellite power levels for the sensitivity test shall be set to the same power level. The 1 dB tolerance or test parameter relaxation for the absolute GPS L1 signal level in C.2.1 in 3GPP TS 37.571-1 shall not be used in reporting the sensitivity measurement results. The above clarification means that, a signal level -146 dBm will lead to a sensitivity level report of -146 dBm, rather than -147 dBm. For Control Plane testing, the GPS L1 engine shall be cold started for every location attempt.

For A-GPS L1 radiated receiver sensitivity measurements, the GPS L1 satellite simulator shall implement GNSS Scenario #1 as defined in 3GPP TS 37.571-5 Section 6.2.1.2.1 for satellites simulated for 3GPP TS 37.571-1 subclause 7, sub-test 1 with the exceptions noted above. The scenario shall be reset before the viable running time expires as defined in the same clause. The scenario shall be executed as required in Section 7.1.1 Sub-Test Number 1 of 3GPP TS 37.571-1 except that random errors shall not be applied to the UE locations and the alternating locations requirement shall not be implemented. Early delivery of Acquisition Assistance Data and Reference Time Data may be provided to the EUT and the SUPL 2.0 or Control Plane Positioning session shall be used over the wireless data connection.

6.13.5.4.3 A-GLONASS for LTE

For the A-GLONASS intermediate channel degradation measurement, the GNSS satellite simulator shall implement GNSS Scenario #1 as defined in 3GPP TS 37.571-5 Section 6.2.1.2.1 for satellites simulated for 3GPP TS 37.571-1 subclause 7, sub-test 5. The usage of GNSS Scenario #1 is predicated from the desire to test A-GNSS performance without any satellite-based augmentation system (SBAS) in use or without any assumption of QZSS support in the UE. The scenario shall be reset before the initial satellites become not visible. The scenario shall be executed as required in Section 7.2 Sub-Test Number 5 of 3GPP TS 37.571-1 except that the reference signal power level for all satellites shall be

-130 dBm for GPS L1 and GLONASS, random errors shall not be applied to the UE locations, and the alternating locations requirement shall not be implemented. Early delivery of Acquisition Assistance Data and Reference Time Data may be provided to the EUT and the default EPS bearer shall be used for the wireless connection to establish the SUPL 2.0 or Control Plane session.

For a device which only supports UE-based A-GNSS and utilizes the test mode identified in [Section 6.13.2.1](#) and [Section 6.13.4.1](#), the test mode shall allow for the following exceptions in the device firmware for UE-based tests:

- Provide Location Information (LPP): In the A-GNSS-ProvideLocationInformation IE of the LPP Provide Location Information message as referenced in TS 36.355 Section 6.5.2.5, both “gnss-SignalMeasurementInformation” and “gnss-LocationInformation” shall be included.

The A-GLONASS radiated receiver sensitivity measurements will be performed for the LTE bands, channel numbers, and the allocations specified in [Table 6-15](#) with the following exceptions: For LTE Band 13, the device shall be tested with an UL RB allocation of 12 RBs with an RBstart of 38 and with an UL RB allocation of 1 RB with an RBstart of 49 as opposed to the UL allocation specified in [Table 6-15](#). For LTE Band 14, the device shall be tested with an UL RB allocation of 12 RBs with an RBstart of 0 and with an UL RB allocation of 1 RB with an RBstart of 0 as opposed to the UL allocation specified in [Table 6-15](#). If the device supports Band 25 and Band 2, then testing is only required to be completed in Band 25. If the device supports Band 26 and Band 5, then testing is only required to be completed in Band 26. If the device supports Band 12 and Band 17, then testing is only required to be completed in Band 12. If the device supports Band 4 and Band 66, then testing is only required to be completed in Band 66. For devices that support transmitter antenna switching, the sensitivity search in Band 13 and Band 14 and the calculation of TIS, UHIS, and PIGS shall be performed with the transmitter connected to each transmit antenna independently. TIS, UHIS, and PIGS results shall be provided for both transmit antennas. Results shall pass for both transmit antennas or the test for Band 13/Band 14 shall be failed.

When submitting a device for LTE A-GNSS testing, the device manufacturer shall include a declaration statement that identifies one of the following options to define the testing to be performed by the test lab:

When submitting a device for LTE A-GNSS testing, the device manufacturer shall include a declaration statement that identifies one of the following options to define the testing to be performed by the test lab:

Option 1: LTE A-GNSS testing is performed without the presence of SIB8 and SIB16 for all LTE bands.

Option 2: LTE A-GNSS testing is performed using the logic below:

1>If the device supports SIB8 or SIB16 for A-GNSS demodulation performance:

2>If the device supports both SIB8 and SIB16 for A-GNSS demodulation performance:

3>If the device supports both LTE and CDMA:

4>Execute testing in all bands using SIB8.

3>Else (i.e. the device is LTE only or the device supports only LTE and legacy 3GPP modes):

4>Execute testing in all bands using SIB16.

2>Else:

3>If the device supports SIB8 only:

4>Execute testing in all bands using SIB8.

3>If the device supports SIB16 only:

4>Execute testing in all bands using SIB16.

1>Else

2>Execute testing in all bands without SIB8 or SIB16 present.

Option 3: LTE A-GNSS testing is performed without the presence of SIB8 and SIB16 for all LTE bands. For a subset of LTE bands selected by the device manufacturer, the sensitivity search and TIS/UHIS/PIGS calculations are repeated with SIB8 and/or SIB16 in accordance with the logic in Option 2. The selection of LTE bands for SIB8 and SIB16 testing should be made with input from the target operators.

Radiated Sensitivity Measurement without SIB8/SIB16:

The A-GLONASS radiated receiver sensitivity measurements shall be performed using the A-GLONASS test parameters in [Table 6-17](#), which are based on 3GPP TS 37.571-1 Test Scenario 7.1.1 Sub-Test Number 5 except for modifications herein.

TABLE 6-17 A-GLONASS TEST PARAMETERS FOR LTE

Test Parameter Description	Test Parameter Settings
Number of satellites	6
HDOP range	1.4 to 2.1
Propagation conditions	AWGN
GNSS time assistance	Coarse, ± 2 s
Phone response time	20 seconds for LPP 16 seconds for RRLP
Acceptable response time to network	20.3 seconds
Success rate	95 successful fixes with the necessary accuracy out of 100 attempts (95%)
Position accuracy	101.3 m

As the A-GLONASS radiated receiver sensitivity measurements are based on a multi-GNSS sub-test, the GLONASS signal power levels need particular treatment compared to the GPS L1 signal power levels. Therefore, the reference signal power level for all GLONASS satellite power levels shall be equal to the power level of the weaker GPS L1 satellites so that there are no GLONASS satellites which are transmitted at a higher signal level. During this test, the GPS L1 satellite power levels are set such that there will be one satellite, which transmits 5 dB higher than the other GPS L1 satellites. The reported A-GLONASS sensitivity level will be based on the power of the weaker satellites. The 1 dB test tolerance or test parameter relaxation for the absolute GNSS signal level in C.2.1 in 3GPP TS 37.571-1 shall not be used in reporting the sensitivity measurement results. The above clarification means that, at signal levels -141 dBm or -146 dBm will lead to a sensitivity level report of -146 dBm, rather than -147 dBm. For Control Plane testing, the GNSS engine shall be cold started for every location attempt.

For A-GLONASS radiated receiver sensitivity measurements, the GNSS satellite simulator shall implement GNSS Scenario #1 as defined in 3GPP TS 37.571-5 Section 6.2.1.2.1 for satellites simulated for 3GPP TS 37.571-1 subclause 7, sub-test 5. The scenario shall be reset before the viable running time expires as defined in the same clause. The scenario shall be executed as required in Section 7.1.1 Sub-Test Number 5 of 3GPP TS 37.571-1 except that random errors shall not be applied to the UE locations and the alternating locations requirement shall not be implemented. Early delivery of Acquisition Assistance Data and Reference Time Data may be provided to the EUT and a SUPL 2.0 or Control Plane Positioning session shall be used over the wireless data connection.

Radiated Sensitivity Measurement with SIB8/SIB16:

The A-GLONASS radiated receiver sensitivity measurements shall be performed using the A-GLONASS test parameters in [Table 6-17](#) which are based on 3GPP TS 37.571-1 Test Scenario 7.1.1 Sub-Test Number 5, and with the exceptions below:

1. All GNSS satellite power levels shall be set to the same power level.
2. The network emulator shall broadcast SIB8 (including the fields and settings shown below) or SIB16 (including all mandatory and optional fields). UTC Time in SIB16 and CDMA system time in SIB8 shall be synchronized to within +/- 100ns of GPS L1 time.

sib8 :

```

{
    systemTimeInfo
    {
        cdma-EUTRA-Synchronisation TRUE,
        cdma-SystemTime synchronousSystemTime : 'xxxxxxxx
                                                xxxxxxxx xxxxxxxx xxxxxxxx'
    },
    searchWindowSize 8,
    parameters1XRTT
    {
    },
    csfb-SupportForDualRxUEs-r9 TRUE
}

```

As the A-GLONASS radiated receiver sensitivity measurements are based on a multi-GNSS sub-test, the GLONASS signal power levels need particular treatment compared to the GPS L1 signal power levels. Therefore, the reference signal power level for all GLONASS satellite power levels shall be equal to the power level of the GPS L1 satellites so that there are no GLONASS satellites which are transmitted at a higher signal level, i.e. all GPS L1 and GLONASS satellite power levels shall be set to the same power level. The 1 dB test tolerance or test parameter relaxation for the absolute GNSS signal level in C.2.1 in 3GPP TS 37.571-1 shall not be used in reporting the sensitivity measurement results. The above clarification means that, a signal level of -146 dBm will lead to a sensitivity level report of -146 dBm, rather than -147 dBm. For Control Plane testing, the GNSS engine shall be cold started for every location attempt.

For A-GLONASS radiated receiver sensitivity measurements, the GNSS satellite simulator shall implement GNSS Scenario #1 as defined in 3GPP TS 37.571-5 Section 6.2.1.2.1 for satellites simulated for 3GPP TS 37.571-1 subclause 7, sub-test 5. The scenario shall be reset before the viable running time expires as defined in the same clause. The scenario shall be executed as required in Section 7.1.1 Sub-Test Number 5 of 3GPP TS 37.571-1 except that random errors shall not be applied to the UE locations and the alternating locations requirement shall not be implemented. Early delivery of Acquisition Assistance Data and Reference Time Data may be provided to the EUT and a SUPL 2.0 or Control Plane Positioning session shall be used over the wireless data connection.

6.13.5.5 LTE Category M1

6.13.5.5.1 LTE Category M1 A-GNSS Testing: General

A-GNSS Receiver Sensitivity measurements shall be performed using test equipment that supports the relevant portions of 3GPP TS 37.571. Unless otherwise specified, the latest versions of the referenced 3GPP documents shall be used.

A-GNSS testing for LTE Cat-M1 Devices will use either User Plane or Control Plane Positioning procedures. The use of User Plane positioning procedures is a deviation from A-GNSS for WCDMA/GSM/CDMA device testing which used Control Plane positioning procedures. Testing is only required in either User Plane or Control Plane and the positioning procedure used for test shall be selected by the manufacturer. The selection should be made with input from the target operators. In the absence of operator input, then User Plane Positioning procedures should be used.

When utilizing User Plane Positioning procedures, A-GNSS for LTE Cat-M1 devices will be tested using the Open Mobile Alliance (OMA) Secure User Plane (SUPL) 2.0 protocol defined in OMA-AD-SUPL-V2_0-20110527-C. RRLP or LPP can be used as the underlying positioning protocol for SUPL 2.0 over the LTE default bearer.

When utilizing User Plane Positioning procedures, the test applies to LTE Cat-M1 devices supporting either RRLP or LPP positioning protocol. The test requires that the device support SUPL 2.0 as the User Plane protocol. If the device supports both RRLP and LPP positioning protocols, either one of these could be used during the test. When utilizing User Plane Positioning procedures, the test only applies to UE-assisted A-GNSS procedures. UE-based A-GNSS testing is not required.

When utilizing Control Plane Positioning procedures, A-GNSS for LTE Cat-M1 devices will be tested using the LPP positioning protocol necessary for testing the Control Plane based tests in 3GPP TS 37.571-1 over the LTE default bearer. When utilizing Control Plane Positioning procedures, the test applies to both UE-based and UE-assisted A-GNSS devices. If both UE-based and UE-assisted A-GNSS is supported by a device, then both modes will be tested.

The same positioning procedures and positioning protocol shall be used for the reference mode testing (A-GPS L1) and the additional GNSS mode testing (A-GLONASS, etc.).

Table 6-18 specifies the mid-channel test channels and UL and DL allocations for LTE Cat-M1 except where specified herein.

TABLE 6-18 MID-BAND TEST CHANNEL SETTINGS FOR LTE CAT-M1

Band	Channel Bandwidth (MHz)	TX Channel	TX Frequency (MHz) [center of TX channel bandwidth] ¹	UL RB Allocation	RX Channel	RX Frequency (MHz) [center of RX channel bandwidth]	DL RB Allocation
2	10	18900	1880	6 RB with RBstart=43	900	1960	4 RB with RBstart=31
4	10	20175	1732.5	6 RB with RBstart=43	2175	2132.5	4 RB with RBstart=31
5 ²	10	20525	836.5	6 RB with RBstart=43	2525	881.5	4 RB with RBstart=31
7	20	21100	2535	6 RB with RBstart=92	3100	2655	4 RB with RBstart=56

TABLE 6-18 MID-BAND TEST CHANNEL SETTINGS FOR LTE CAT-M1

Band	Channel Bandwidth (MHz)	TX Channel	TX Frequency (MHz) [center of TX channel bandwidth] ¹	UL RB Allocation	RX Channel	RX Frequency (MHz) [center of RX channel bandwidth]	DL RB Allocation
12	5	23095	707.5	6 RB with RBstart=19	5095	737.5	4 RB with RBstart=19
13	10	23230	782	6 RB with RBstart=1	5230	751	4 RB with RBstart=31
26 ²	5	26865	831.5	6 RB with RBstart=19	8865	876.5	4 RB with RBstart=19
41	20	40620	2593	6 RB with RBstart=92	40620	2593	4 RB with RBstart=56
71	10	133297	680.5	6 RB with RBstart=43	68761	635.94	4 RB with RBstart=31

Note 1: The frequencies listed in this table are the center of the channel bandwidth and not the center of the RB allocation.
Note 2: If the device supports Band 26 and Band 5, then testing is only required to be completed in Band 26.

For the tests that operate at maximum output power, the UE transmit power shall be set to the maximum by sending continuous uplink power control "up" commands in every uplink scheduling information to the UE and allowing at least 200ms for the UE to reach its maximum level. As the 3GPP reference does not make any mention of p-Max, nor is p-Max included in the default message content defined in 3GPP TS 36.508, p-Max shall not be signaled during attach procedures or during measurements.

For the tests that do not operate at maximum output power such as the radiated 3D C/N0 pattern measurement, it is up to the implementer to utilize UE power control such that the requirement specified can be met.

No A-GNSS intermediate channel degradation measurements are required for LTE Cat-M1 devices.

Note: A-GNSS for LTE Cat-M1 testing is only required if the EUT supports a voice call while using an LTE Cat-M1 connection (e.g., VoLTE, VoIP).

6.13.5.5.2 A-GPS L1 Test Procedure for LTE Category M1

For the A-GPS L1 radiated 3D C/N0 pattern measurement and the A-GPS L1 intermediate channel degradation measurement, the GPS satellite simulator shall implement GNSS Scenario #1 as defined in 3GPP TS 37.571-5 Section 6.2.1.2.1 for satellites simulated for 3GPP TS 37.571-1 subclause 7, sub-test 1. The scenario shall be reset before the initial satellites become not visible. The scenario shall be executed as required in Section 7.2 Sub-Test Number 1 of 3GPP TS 37.571-1 except that random errors shall not be applied to the UE locations and the alternating locations requirement shall not be implemented. Early delivery of Acquisition Assistance Data and Reference Time Data may be provided to the EUT and the default EPS bearer shall be used for the wireless connection to establish the SUPL 2.0 or Control Plane session.

For a device which only supports UE-based A-GNSS and utilizes the test mode identified in Section 6.13.2.1 and Section 6.13.4.1, the test mode shall allow for the following exceptions in the device firmware for UE-based tests:

- Provide Location Information (LPP): In the A-GNSS-ProvideLocationInformation IE of the LPP Provide Location Information message as referenced in TS 36.355 Section 6.5.2.5,

both “gnss-SignalMeasurementInformation” and “gnss-LocationInformation” shall be included.

The A-GPS L1 radiated receiver sensitivity measurements will be performed for the LTE Cat-M1 bands, channel numbers, and the allocations specified in [Table 6-18](#) with the following exceptions. For LTE Cat-M1 Band 13, the device shall be tested with an UL RB allocation of 6 RBs with an RBstart of 43 and with an UL RB allocation of 1 RB with an RBstart of 48 as opposed to the UL allocation specified in [Table 6-18](#). If the device supports Band 26 and Band 5, then testing is only required to be completed in Band 26. For devices that support transmitter antenna switching, the sensitivity search in Band 13 and the calculation of TIS, UHIS, and PIGS shall be performed with the transmitter connected to each transmit antenna independently. TIS, UHIS, and PIGS results shall be provided for both transmit antennas. Results shall pass for both transmit antennas or the test for Band 13 shall be failed.

When submitting a Cat-M1 device for LTE A-GNSS testing, the device manufacturer shall include a declaration statement that identifies one of the following options to define the testing to be performed by the test lab:

- **Option 1:** LTE Cat-M1 A-GNSS testing is performed without the presence of SIB16 for all LTE bands.
- **Option 2:** LTE Cat-M1 A-GNSS testing is performed with SIB16 present for all LTE bands.
- **Option 3:** LTE Cat-M1 A-GNSS testing is performed without the presence of SIB16 for all LTE bands. For a subset of LTE bands selected by the device manufacturer, the sensitivity search and TIS/UHIS/PIGS calculations are repeated with SIB16. The selection of LTE bands for SIB16 testing should be made with input from the target operators.

Radiated Sensitivity Measurement without SIB16:

The A-GPS L1 radiated receiver sensitivity measurements shall be performed using the A-GPS L1 test parameters in [Table 6-16](#), which are based on 3GPP TS 37.571-1 Test Scenario 7.1.1 Sub-Test Number 1 except for modifications herein.

Note that the satellite power levels for the sensitivity test are such that there will be one satellite, which transmits 5 dB higher than the other satellites. The reported sensitivity level will be based on the power of the weaker satellites. The 1 dB test tolerance or test parameter relaxation for the absolute GPS L1 signal level in C.2.1 in 3GPP TS 37.571-1 shall not be used in reporting the sensitivity measurement results. The above clarification means that, at signal levels -141 dBm and -146 dBm will lead to a sensitivity level report of -146 dBm, rather than -147 dBm. For Control Plane testing, the GPS L1 engine shall be cold started for every location attempt.

For A-GPS L1 radiated receiver sensitivity measurements, the GPS L1 satellite simulator shall implement GNSS Scenario #1 as defined in 3GPP TS 37.571-5 Section 6.2.1.2.1 for satellites simulated for 3GPP TS 37.571-1 subclause 7, sub-test 1. The scenario shall be reset before the viable running time expires as defined in the same clause. The scenario shall be executed as required in Section 7.1.1 Sub-Test Number 1 of 3GPP TS 37.571-1 except that random errors shall not be applied to the UE locations and the alternating locations requirement shall not be implemented. Early delivery of Acquisition Assistance Data and Reference Time Data may be provided to the EUT and the SUPL 2.0 or Control Plane Positioning session shall be used over the wireless data connection.

Radiated Sensitivity Measurement with SIB16:

The A-GPS L1 radiated receiver sensitivity measurements shall be performed using the A-GPS L1 test parameters in [Table 6-16](#), which are based on 3GPP TS 37.571-1 Test Scenario 7.1.1 Sub-Test Number 1, and with the exceptions below:

- All satellite power levels shall be set to the same power level.
- The network emulator shall broadcast SIB16 (including all mandatory and optional fields). UTC Time in SIB16 shall be synchronized to within +/- 100ns of GPS L1 time.

All satellite power levels for the sensitivity test shall be set to the same power level. The 1 dB test tolerance or test parameter relaxation for the absolute GPS L1 signal level in C.2.1 in 3GPP TS 37.571-1 shall not be used in reporting the sensitivity measurement results. The above clarification means that, a signal level -146 dBm will lead to a sensitivity level report of -146 dBm, rather than -147 dBm. For Control Plane testing, the GPS L1 engine shall be cold started for every location attempt.

For A-GPS L1 radiated receiver sensitivity measurements, the GPS satellite simulator shall implement GNSS Scenario #1 as defined in 3GPP TS 37.571-5 Section 6.2.1.2.1 for satellites simulated for 3GPP TS 37.571-1 subclause 7, sub-test 1 with the exceptions noted above. The scenario shall be reset before the viable running time expires as defined in the same clause. The scenario shall be executed as required in Section 7.1.1 Sub-Test Number 1 of 3GPP TS 37.571-1 except that random errors shall not be applied to the UE locations and the alternating locations requirement shall not be implemented. Early delivery of Acquisition Assistance Data and Reference Time Data may be provided to the EUT and the SUPL 2.0 or Control Plane Positioning session shall be used over the wireless data connection.

6.13.5.5.3 A-GLONASS for LTE Category M1

For the A-GLONASS intermediate channel degradation measurement, the GNSS satellite simulator shall implement GNSS Scenario #1 as defined in 3GPP TS 37.571-5 Section 6.2.1.2.1 for satellites simulated for 3GPP TS 37.571-1 subclause 7, sub-test 5. The usage of GNSS Scenario #1 is predicated from the desire to test A-GNSS performance without any satellite-based augmentation system (SBAS) in use or without any assumption of QZSS support in the UE. The scenario shall be reset before the initial satellites become not visible. The scenario shall be executed as required in Section 7.2 Sub-Test Number 5 of 3GPP TS 37.571-1 except that the reference signal power level for all satellites shall be -130 dBm for A-GPS L1 and A-GLONASS, random errors shall not be applied to the UE locations, and the alternating locations requirement shall not be implemented. Early delivery of Acquisition Assistance Data and Reference Time Data may be provided to the EUT and the default EPS bearer shall be used for the wireless connection to establish the SUPL 2.0 or Control Plane session.

For a device which only supports UE-based A-GNSS and utilizes the test mode identified in [Section 6.13.2.1](#) and [Section 6.13.4.1](#), the test mode shall allow for the following exceptions in the device firmware for UE-based tests:

Provide Location Information (LPP): In the A-GNSS-ProvideLocationInformation IE of the LPP Provide Location Information message as referenced in TS 36.355 Section 6.5.2.5, both “gnss-SignalMeasurementInformation” and “gnss-LocationInformation” shall be included.

The A-GLONASS radiated receiver sensitivity measurements will be performed for the LTE bands, channel numbers, and the allocations specified in [Table 6-18](#) with the following exceptions: For LTE Cat-M1 Band 13, the device shall be tested with an UL RB allocation of 6 RBs with an RBstart of 43 and with an UL RB allocation of 1 RB with an RBstart of 48 as opposed to the UL allocation specified in [Table 6-18](#). If the device supports Band 26 and Band 5, then testing is only required to be completed in Band 26. For devices that support transmitter antenna switching, the sensitivity search in Band 13 and the calculation of TIS, UHIS, and PIGS shall be performed with the transmitter connected to each transmit antenna independently. TIS, UHIS, and PIGS results shall be provided for both transmit antennas. Results shall pass for both transmit antennas or the test for Band 13 shall be failed.

When submitting a device for LTE Cat-M1 A-GNSS testing, the device manufacturer shall include a declaration statement that identifies one of the following options to define the testing to be performed by the test lab:

- **Option 1:** LTE Cat-M1 A-GNSS testing is performed without the presence of SIB16 for all LTE bands.
- **Option 2:** LTE Cat-M1 A-GNSS testing is performed with SIB16 present for all LTE bands.

- **Option 3:** LTE Cat-M1 A-GNSS testing is performed without the presence of SIB16 for all LTE bands. For a subset of LTE bands selected by the device manufacturer, the sensitivity search and TIS/UHIS/PIGS calculations are repeated with SIB16. The selection of LTE bands for SIB16 testing should be made with input from the target operators.

Radiated Sensitivity Measurement without SIB16:

The A-GLONASS radiated receiver sensitivity measurements shall be performed using the A-GLONASS test parameters in [Table 6-17](#), which are based on 3GPP TS 37.571-1 Test Scenario 7.1.1 Sub-Test Number 5 except for modifications herein.

As the A-GLONASS radiated receiver sensitivity measurements are based on a multi-GNSS sub-test, the A-GLONASS signal power levels need particular treatment compared to the A-GPS L1 signal power levels. Therefore, the reference signal power level for all GLONASS satellite power levels shall be equal to the power level of the weaker GPS L1 satellites so that there are no GLONASS satellites which are transmitted at a higher signal level. During this test, the GPS L1 satellite power levels are set such that there will be one satellite, which transmits 5 dB higher than the other GPS L1 satellites. The reported A-GLONASS sensitivity level will be based on the power of the weaker satellites. The 1 dB test tolerance or test parameter relaxation for the absolute GNSS signal level in C.2.1 in 3GPP TS 37.571-1 shall not be used in reporting the sensitivity measurement results. The above clarification means that, at signal levels -141 dBm and -146 dBm will lead to a sensitivity level report of -146 dBm, rather than -147 dBm. For Control Plane testing, the GPS L1 engine shall be cold started for every location attempt.

For A-GLONASS radiated receiver sensitivity measurements, the GNSS satellite simulator shall implement GNSS Scenario #1 as defined in 3GPP TS 37.571-5 Section 6.2.1.2.1 for satellites simulated for 3GPP TS 37.571-1 subclause 7, sub-test 5. The scenario shall be reset before the viable running time expires as defined in the same clause. The scenario shall be executed as required in Section 7.1.1 Sub-Test Number 5 of 3GPP TS 37.571-1 except that random errors shall not be applied to the UE locations and the alternating locations requirement shall not be implemented. Early delivery of Acquisition Assistance Data and Reference Time Data may be provided to the EUT and a SUPL 2.0 or Control Plane Positioning session shall be used over the wireless data connection.

Radiated Sensitivity Measurement with SIB16:

The A-GLONASS radiated receiver sensitivity measurements shall be performed using the A-GLONASS test parameters in [Table 6-17](#), which are based on 3GPP TS 37.571-1 Test Scenario 7.1.1 Sub-Test Number 5, and with the exceptions below:

- All GPS L1 satellite power levels shall be set to the same power level.
- The network emulator shall broadcast SIB16 (including all mandatory and optional fields). UTC Time in SIB16 shall be synchronized to within +/- 100ns of GPS L1 time.

As the A-GLONASS radiated receiver sensitivity measurements are based on a multi-GNSS sub-test, the A-GLONASS signal power levels need particular treatment compared to the A-GPS L1 signal power levels. Therefore, the reference signal power level for all GLONASS satellite power levels shall be equal to the power level of the GPS L1 satellites so that there are no GLONASS satellites which are transmitted at a higher signal level, i.e. all GPS L1 and GLONASS satellite power levels shall be set to the same power level. The 1 dB test tolerance or test parameter relaxation for the absolute GNSS signal level in C.2.1 in 3GPP TS 37.571-1 shall not be used in reporting the sensitivity measurement results. The above clarification means that, a signal level of -146 dBm will lead to a sensitivity level report of -146 dBm, rather than -147 dBm. For Control Plane testing, the GPS L1 engine shall be cold started for every location attempt.

For A-GLONASS radiated receiver sensitivity measurements, the GNSS satellite simulator shall implement GNSS Scenario #1 as defined in 3GPP TS 37.571-5 Section 6.2.1.2.1 for satellites simulated for 3GPP TS 37.571-1 subclause 7, sub-test 5. The scenario shall be reset before the viable running time expires as defined in the same clause. The scenario shall be executed as required in Section 7.1.1 Sub-Test Number 5 of 3GPP TS 37.571-1 except that random errors shall not be applied to the UE locations and the alternating locations requirement shall not be implemented. Early delivery of Acquisition Assistance Data and Reference Time Data may be provided to the EUT and a SUPL 2.0 or Control Plane Positioning session shall be used over the wireless data connection.

6.13.6 Criteria

Results shall be reported as specified in [Appendix B](#) using the figures of merit given in [Appendix B.3](#). [Appendix B.1](#) contains the pass/fail OTA tables for A-GNSS. Reports shall include results for free-space and head/hand configurations (if applicable) or wrist-worn configurations (if applicable, also change HL/HR to WL/WR in the reporting tables) across all channels measured with the EUT antenna extended and retracted.

A-GNSS intermediate channel degradation test results shall be provided in a file format equivalent to that specified in [Appendix B.1](#).

[Table 6-19](#), [Table 6-20](#) and [Table 6-21](#) contain the pass/fail limits for A-GPS L1 for devices held to the head for voice, integrated devices and wrist-worn devices, respectively. [Table 6-22](#), [Table 6-23](#) and [Table 6-24](#) contain the pass/fail limits for A-GLONASS for devices held to the head for voice, integrated devices and wrist-worn devices, respectively.

TABLE 6-19 A-GPS L1 MAXIMUM TIS/UHIS/PIGS LEVEL (IN DBM) REQUIREMENTS FOR THE PRIMARY MECHANICAL MODE FOR DEVICES HELD TO THE HEAD FOR VOICE¹

Band	Positioning Method	SIB	Device Width (mm) ²	BHHL and BHHR			HL and HR		
				TIS	UHIS	PIGS	TIS	UHIS	PIGS
CDMA 800	Control Plane / MS-Assisted	SIB8	≤72	TBD	TBD	TBD	TBD	TBD	TBD
			>72	TBD	TBD	TBD	TBD	TBD	TBD
CDMA 1900			≤72	TBD	TBD	TBD	TBD	TBD	TBD
			>72	TBD	TBD	TBD	TBD	TBD	TBD
CDMA 1700/2100			≤72	TBD	TBD	TBD	TBD	TBD	TBD
			>72	TBD	TBD	TBD	TBD	TBD	TBD

TABLE 6-19 A-GPS L1 MAXIMUM TIS/UHIS/PIGS LEVEL (IN dBm) REQUIREMENTS FOR THE PRIMARY MECHANICAL MODE FOR DEVICES HELD TO THE HEAD FOR VOICE¹

Band	Positioning Method	SIB	Device Width (mm) ²	BHHL and BHHR			HL and HR		
				TIS	UHIS	PIGS	TIS	UHIS	PIGS
GSM 850	Control Plane / UE-Based	N/A	≤72	TBD	TBD	TBD	TBD	TBD	TBD
			>72	TBD	TBD	TBD	TBD	TBD	TBD
GSM 1900			≤72	TBD	TBD	TBD	TBD	TBD	TBD
			>72	TBD	TBD	TBD	TBD	TBD	TBD
UMTS 850			≤72	TBD	TBD	TBD	TBD	TBD	TBD
			>72	TBD	TBD	TBD	TBD	TBD	TBD
UMTS 1900			≤72	TBD	TBD	TBD	TBD	TBD	TBD
			>72	TBD	TBD	TBD	TBD	TBD	TBD
UMTS 1700/2100			≤72	TBD	TBD	TBD	TBD	TBD	TBD
			>72	TBD	TBD	TBD	TBD	TBD	TBD
LTE Band 71			≤72	TBD	TBD	TBD	TBD	TBD	TBD
			>72	TBD	TBD	TBD	TBD	TBD	TBD
LTE Band 12			≤72	TBD	TBD	TBD	TBD	TBD	TBD
			>72	TBD	TBD	TBD	TBD	TBD	TBD
LTE Band 17			≤72	TBD	TBD	TBD	TBD	TBD	TBD
			>72	TBD	TBD	TBD	TBD	TBD	TBD
LTE Band 13			≤72	TBD	TBD	TBD	TBD	TBD	TBD
			>72	TBD	TBD	TBD	TBD	TBD	TBD
LTE Band 14			≤72	TBD	TBD	TBD	TBD	TBD	TBD
			>72	TBD	TBD	TBD	TBD	TBD	TBD
LTE Band 26	≤72	TBD	TBD	TBD	TBD	TBD	TBD		
	>72	TBD	TBD	TBD	TBD	TBD	TBD		
LTE Band 5	≤72	TBD	TBD	TBD	TBD	TBD	TBD		
	>72	TBD	TBD	TBD	TBD	TBD	TBD		
LTE Band 70	≤72	TBD	TBD	TBD	TBD	TBD	TBD		
	>72	TBD	TBD	TBD	TBD	TBD	TBD		
LTE Band 4	≤72	TBD	TBD	TBD	TBD	TBD	TBD		
	>72	TBD	TBD	TBD	TBD	TBD	TBD		

TABLE 6-19 A-GPS L1 MAXIMUM TIS/UHIS/PIGS LEVEL (IN dBm) REQUIREMENTS FOR THE PRIMARY MECHANICAL MODE FOR DEVICES HELD TO THE HEAD FOR VOICE¹

Band	Positioning Method	SIB	Device Width (mm) ²	BHHL and BHHR			HL and HR		
				TIS	UHIS	PIGS	TIS	UHIS	PIGS
LTE Band 66	Control Plane / UE-Based	N/A	≤72	TBD	TBD	TBD	TBD	TBD	TBD
			>72	TBD	TBD	TBD	TBD	TBD	TBD
LTE Band 2			≤72	TBD	TBD	TBD	TBD	TBD	TBD
			>72	TBD	TBD	TBD	TBD	TBD	TBD
LTE Band 25			≤72	TBD	TBD	TBD	TBD	TBD	TBD
			>72	TBD	TBD	TBD	TBD	TBD	TBD
LTE Band 30			≤72	TBD	TBD	TBD	TBD	TBD	TBD
			>72	TBD	TBD	TBD	TBD	TBD	TBD
LTE Band 7			≤72	TBD	TBD	TBD	TBD	TBD	TBD
			>72	TBD	TBD	TBD	TBD	TBD	TBD
LTE Band 41			≤72	TBD	TBD	TBD	TBD	TBD	TBD
			>72	TBD	TBD	TBD	TBD	TBD	TBD
LTE Band 48	≤72	TBD	TBD	TBD	TBD	TBD	TBD		
	>72	TBD	TBD	TBD	TBD	TBD	TBD		

TABLE 6-19 A-GPS L1 MAXIMUM TIS/UHIS/PIGS LEVEL (IN dBm) REQUIREMENTS FOR THE PRIMARY MECHANICAL MODE FOR DEVICES HELD TO THE HEAD FOR VOICE¹

Band	Positioning Method	SIB	Device Width (mm) ²	BHHL and BHHR			HL and HR		
				TIS	UHIS	PIGS	TIS	UHIS	PIGS
GSM 850	Control Plane / UE-Assisted	N/A	≤72	TBD	TBD	TBD	TBD	TBD	TBD
			>72	TBD	TBD	TBD	TBD	TBD	TBD
GSM 1900			≤72	TBD	TBD	TBD	TBD	TBD	TBD
			>72	TBD	TBD	TBD	TBD	TBD	TBD
UMTS 850			≤72	TBD	TBD	TBD	TBD	TBD	TBD
			>72	TBD	TBD	TBD	TBD	TBD	TBD
UMTS 1900			≤72	TBD	TBD	TBD	TBD	TBD	TBD
			>72	TBD	TBD	TBD	TBD	TBD	TBD
UMTS 1700/2100			≤72	TBD	TBD	TBD	TBD	TBD	TBD
			>72	TBD	TBD	TBD	TBD	TBD	TBD
LTE Band 71			≤72	TBD	TBD	TBD	TBD	TBD	TBD
			>72	TBD	TBD	TBD	TBD	TBD	TBD
LTE Band 12			≤72	TBD	TBD	TBD	TBD	TBD	TBD
			>72	TBD	TBD	TBD	TBD	TBD	TBD
LTE Band 17			≤72	TBD	TBD	TBD	TBD	TBD	TBD
			>72	TBD	TBD	TBD	TBD	TBD	TBD
LTE Band 13			≤72	TBD	TBD	TBD	TBD	TBD	TBD
			>72	TBD	TBD	TBD	TBD	TBD	TBD
LTE Band 14			≤72	TBD	TBD	TBD	TBD	TBD	TBD
			>72	TBD	TBD	TBD	TBD	TBD	TBD
LTE Band 26	≤72	TBD	TBD	TBD	TBD	TBD	TBD		
	>72	TBD	TBD	TBD	TBD	TBD	TBD		
LTE Band 5	≤72	TBD	TBD	TBD	TBD	TBD	TBD		
	>72	TBD	TBD	TBD	TBD	TBD	TBD		

TABLE 6-19 A-GPS L1 MAXIMUM TIS/UHIS/PIGS LEVEL (IN dBm) REQUIREMENTS FOR THE PRIMARY MECHANICAL MODE FOR DEVICES HELD TO THE HEAD FOR VOICE¹

Band	Positioning Method	SIB	Device Width (mm) ²	BHHL and BHHR			HL and HR		
				TIS	UHIS	PIGS	TIS	UHIS	PIGS
LTE Band 70	Control Plane / UE-Assisted	N/A	≤72	TBD	TBD	TBD	TBD	TBD	TBD
			>72	TBD	TBD	TBD	TBD	TBD	TBD
LTE Band 4			≤72	TBD	TBD	TBD	TBD	TBD	TBD
			>72	TBD	TBD	TBD	TBD	TBD	TBD
LTE Band 66			≤72	TBD	TBD	TBD	TBD	TBD	TBD
			>72	TBD	TBD	TBD	TBD	TBD	TBD
LTE Band 2			≤72	TBD	TBD	TBD	TBD	TBD	TBD
			>72	TBD	TBD	TBD	TBD	TBD	TBD
LTE Band 25			≤72	TBD	TBD	TBD	TBD	TBD	TBD
			>72	TBD	TBD	TBD	TBD	TBD	TBD
LTE Band 30			≤72	TBD	TBD	TBD	TBD	TBD	TBD
			>72	TBD	TBD	TBD	TBD	TBD	TBD
LTE Band 7			≤72	TBD	TBD	TBD	TBD	TBD	TBD
			>72	TBD	TBD	TBD	TBD	TBD	TBD
LTE Band 41			≤72	TBD	TBD	TBD	TBD	TBD	TBD
			>72	TBD	TBD	TBD	TBD	TBD	TBD
LTE Band 48	≤72	TBD	TBD	TBD	TBD	TBD	TBD		
	>72	TBD	TBD	TBD	TBD	TBD	TBD		

TABLE 6-19 A-GPS L1 MAXIMUM TIS/UHIS/PIGS LEVEL (IN dBm) REQUIREMENTS FOR THE PRIMARY MECHANICAL MODE FOR DEVICES HELD TO THE HEAD FOR VOICE¹

Band	Positioning Method	SIB	Device Width (mm) ²	BHHL and BHHR			HL and HR		
				TIS	UHIS	PIGS	TIS	UHIS	PIGS
LTE Band 71	SUPL 2.0 / UE-Assisted	N/A	≤72	TBD	TBD	TBD	TBD	TBD	TBD
			>72	TBD	TBD	TBD	TBD	TBD	TBD
LTE Band 12			≤72	TBD	TBD	TBD	TBD	TBD	TBD
			>72	TBD	TBD	TBD	TBD	TBD	TBD
LTE Band 17			≤72	TBD	TBD	TBD	TBD	TBD	TBD
			>72	TBD	TBD	TBD	TBD	TBD	TBD
LTE Band 13			≤72	TBD	TBD	TBD	TBD	TBD	TBD
			>72	TBD	TBD	TBD	TBD	TBD	TBD
LTE Band 14			≤72	TBD	TBD	TBD	TBD	TBD	TBD
			>72	TBD	TBD	TBD	TBD	TBD	TBD
LTE Band 26			≤72	TBD	TBD	TBD	TBD	TBD	TBD
			>72	TBD	TBD	TBD	TBD	TBD	TBD
LTE Band 5			≤72	TBD	TBD	TBD	TBD	TBD	TBD
			>72	TBD	TBD	TBD	TBD	TBD	TBD
LTE Band 70			≤72	TBD	TBD	TBD	TBD	TBD	TBD
			>72	TBD	TBD	TBD	TBD	TBD	TBD
LTE Band 4			≤72	TBD	TBD	TBD	TBD	TBD	TBD
			>72	TBD	TBD	TBD	TBD	TBD	TBD
LTE Band 66			≤72	TBD	TBD	TBD	TBD	TBD	TBD
			>72	TBD	TBD	TBD	TBD	TBD	TBD
LTE Band 2	≤72	TBD	TBD	TBD	TBD	TBD	TBD		
	>72	TBD	TBD	TBD	TBD	TBD	TBD		
LTE Band 25	≤72	TBD	TBD	TBD	TBD	TBD	TBD		
	>72	TBD	TBD	TBD	TBD	TBD	TBD		
LTE Band 30	≤72	TBD	TBD	TBD	TBD	TBD	TBD		
	>72	TBD	TBD	TBD	TBD	TBD	TBD		
LTE Band 7	≤72	TBD	TBD	TBD	TBD	TBD	TBD		
	>72	TBD	TBD	TBD	TBD	TBD	TBD		
LTE Band 41	≤72	TBD	TBD	TBD	TBD	TBD	TBD		
	>72	TBD	TBD	TBD	TBD	TBD	TBD		
LTE Band 48	≤72	TBD	TBD	TBD	TBD	TBD	TBD		
	>72	TBD	TBD	TBD	TBD	TBD	TBD		

TABLE 6-19 A-GPS L1 MAXIMUM TIS/UHIS/PIGS LEVEL (IN dBm) REQUIREMENTS FOR THE PRIMARY MECHANICAL MODE FOR DEVICES HELD TO THE HEAD FOR VOICE¹

Band	Positioning Method	SIB	Device Width (mm) ²	BHHL and BHHR			HL and HR		
				TIS	UHIS	PIGS	TIS	UHIS	PIGS
LTE Band 71	Control Plane / UE-Based	SIB8 and SIB16	≤72	TBD	TBD	TBD	TBD	TBD	TBD
			>72	TBD	TBD	TBD	TBD	TBD	TBD
LTE Band 12			≤72	TBD	TBD	TBD	TBD	TBD	TBD
			>72	TBD	TBD	TBD	TBD	TBD	TBD
LTE Band 17			≤72	TBD	TBD	TBD	TBD	TBD	TBD
			>72	TBD	TBD	TBD	TBD	TBD	TBD
LTE Band 13			≤72	TBD	TBD	TBD	TBD	TBD	TBD
			>72	TBD	TBD	TBD	TBD	TBD	TBD
LTE Band 14			≤72	TBD	TBD	TBD	TBD	TBD	TBD
			>72	TBD	TBD	TBD	TBD	TBD	TBD
LTE Band 26			≤72	TBD	TBD	TBD	TBD	TBD	TBD
			>72	TBD	TBD	TBD	TBD	TBD	TBD
LTE Band 5			≤72	TBD	TBD	TBD	TBD	TBD	TBD
			>72	TBD	TBD	TBD	TBD	TBD	TBD
LTE Band 70			≤72	TBD	TBD	TBD	TBD	TBD	TBD
			>72	TBD	TBD	TBD	TBD	TBD	TBD
LTE Band 4			≤72	TBD	TBD	TBD	TBD	TBD	TBD
			>72	TBD	TBD	TBD	TBD	TBD	TBD
LTE Band 66			≤72	TBD	TBD	TBD	TBD	TBD	TBD
			>72	TBD	TBD	TBD	TBD	TBD	TBD
LTE Band 2	≤72	TBD	TBD	TBD	TBD	TBD	TBD		
	>72	TBD	TBD	TBD	TBD	TBD	TBD		
LTE Band 25	≤72	TBD	TBD	TBD	TBD	TBD	TBD		
	>72	TBD	TBD	TBD	TBD	TBD	TBD		
LTE Band 30	≤72	TBD	TBD	TBD	TBD	TBD	TBD		
	>72	TBD	TBD	TBD	TBD	TBD	TBD		
LTE Band 7	≤72	TBD	TBD	TBD	TBD	TBD	TBD		
	>72	TBD	TBD	TBD	TBD	TBD	TBD		
LTE Band 41	≤72	TBD	TBD	TBD	TBD	TBD	TBD		
	>72	TBD	TBD	TBD	TBD	TBD	TBD		
LTE Band 48	≤72	TBD	TBD	TBD	TBD	TBD	TBD		
	>72	TBD	TBD	TBD	TBD	TBD	TBD		

TABLE 6-19 A-GPS L1 MAXIMUM TIS/UHIS/PIGS LEVEL (IN dBm) REQUIREMENTS FOR THE PRIMARY MECHANICAL MODE FOR DEVICES HELD TO THE HEAD FOR VOICE¹

Band	Positioning Method	SIB	Device Width (mm) ²	BHHL and BHHR			HL and HR		
				TIS	UHIS	PIGS	TIS	UHIS	PIGS
LTE Band 71	Control Plane / UE-Assisted	SIB8 and SIB16	≤72	TBD	TBD	TBD	TBD	TBD	TBD
			>72	TBD	TBD	TBD	TBD	TBD	TBD
LTE Band 12			≤72	TBD	TBD	TBD	TBD	TBD	TBD
			>72	TBD	TBD	TBD	TBD	TBD	TBD
LTE Band 17			≤72	TBD	TBD	TBD	TBD	TBD	TBD
			>72	TBD	TBD	TBD	TBD	TBD	TBD
LTE Band 13			≤72	TBD	TBD	TBD	TBD	TBD	TBD
			>72	TBD	TBD	TBD	TBD	TBD	TBD
LTE Band 14			≤72	TBD	TBD	TBD	TBD	TBD	TBD
			>72	TBD	TBD	TBD	TBD	TBD	TBD
LTE Band 26			≤72	TBD	TBD	TBD	TBD	TBD	TBD
			>72	TBD	TBD	TBD	TBD	TBD	TBD
LTE Band 5			≤72	TBD	TBD	TBD	TBD	TBD	TBD
			>72	TBD	TBD	TBD	TBD	TBD	TBD
LTE Band 70			≤72	TBD	TBD	TBD	TBD	TBD	TBD
			>72	TBD	TBD	TBD	TBD	TBD	TBD
LTE Band 4			≤72	TBD	TBD	TBD	TBD	TBD	TBD
			>72	TBD	TBD	TBD	TBD	TBD	TBD
LTE Band 66			≤72	TBD	TBD	TBD	TBD	TBD	TBD
			>72	TBD	TBD	TBD	TBD	TBD	TBD
LTE Band 2	≤72	TBD	TBD	TBD	TBD	TBD	TBD		
	>72	TBD	TBD	TBD	TBD	TBD	TBD		
LTE Band 25	≤72	TBD	TBD	TBD	TBD	TBD	TBD		
	>72	TBD	TBD	TBD	TBD	TBD	TBD		
LTE Band 30	≤72	TBD	TBD	TBD	TBD	TBD	TBD		
	>72	TBD	TBD	TBD	TBD	TBD	TBD		
LTE Band 7	≤72	TBD	TBD	TBD	TBD	TBD	TBD		
	>72	TBD	TBD	TBD	TBD	TBD	TBD		
LTE Band 41	≤72	TBD	TBD	TBD	TBD	TBD	TBD		
	>72	TBD	TBD	TBD	TBD	TBD	TBD		
LTE Band 48	≤72	TBD	TBD	TBD	TBD	TBD	TBD		
	>72	TBD	TBD	TBD	TBD	TBD	TBD		

TABLE 6-19 A-GPS L1 MAXIMUM TIS/UHIS/PIGS LEVEL (IN dBm) REQUIREMENTS FOR THE PRIMARY MECHANICAL MODE FOR DEVICES HELD TO THE HEAD FOR VOICE¹

Band	Positioning Method	SIB	Device Width (mm) ²	BHHL and BHHR			HL and HR		
				TIS	UHIS	PIGS	TIS	UHIS	PIGS
LTE Band 71	SUPL 2.0 / UE-Assisted	SIB8 and SIB16	≤72	TBD	TBD	TBD	TBD	TBD	TBD
			>72	TBD	TBD	TBD	TBD	TBD	TBD
LTE Band 12			≤72	TBD	TBD	TBD	TBD	TBD	TBD
			>72	TBD	TBD	TBD	TBD	TBD	TBD
LTE Band 17			≤72	TBD	TBD	TBD	TBD	TBD	TBD
			>72	TBD	TBD	TBD	TBD	TBD	TBD
LTE Band 13			≤72	TBD	TBD	TBD	TBD	TBD	TBD
			>72	TBD	TBD	TBD	TBD	TBD	TBD
LTE Band 14			≤72	TBD	TBD	TBD	TBD	TBD	TBD
			>72	TBD	TBD	TBD	TBD	TBD	TBD
LTE Band 26			≤72	TBD	TBD	TBD	TBD	TBD	TBD
			>72	TBD	TBD	TBD	TBD	TBD	TBD
LTE Band 5			≤72	TBD	TBD	TBD	TBD	TBD	TBD
			>72	TBD	TBD	TBD	TBD	TBD	TBD
LTE Band 70			≤72	TBD	TBD	TBD	TBD	TBD	TBD
			>72	TBD	TBD	TBD	TBD	TBD	TBD
LTE Band 4			≤72	TBD	TBD	TBD	TBD	TBD	TBD
			>72	TBD	TBD	TBD	TBD	TBD	TBD
LTE Band 66			≤72	TBD	TBD	TBD	TBD	TBD	TBD
			>72	TBD	TBD	TBD	TBD	TBD	TBD
LTE Band 2	≤72	TBD	TBD	TBD	TBD	TBD	TBD		
	>72	TBD	TBD	TBD	TBD	TBD	TBD		
LTE Band 25	≤72	TBD	TBD	TBD	TBD	TBD	TBD		
	>72	TBD	TBD	TBD	TBD	TBD	TBD		
LTE Band 30	≤72	TBD	TBD	TBD	TBD	TBD	TBD		
	>72	TBD	TBD	TBD	TBD	TBD	TBD		
LTE Band 7	≤72	TBD	TBD	TBD	TBD	TBD	TBD		
	>72	TBD	TBD	TBD	TBD	TBD	TBD		
LTE Band 41	≤72	TBD	TBD	TBD	TBD	TBD	TBD		
	>72	TBD	TBD	TBD	TBD	TBD	TBD		
LTE Band 48	≤72	TBD	TBD	TBD	TBD	TBD	TBD		
	>72	TBD	TBD	TBD	TBD	TBD	TBD		

Note 1: Primary Mechanical Mode refers to device configured in preferred mode per manufacturer instructions (typically means antenna extended, fold or portrait slide open, but depends on form factor).

Note 2: Differences between requirements for devices wider and narrower than 72 mm reflect observed differences in OTA performance with different hand phantoms of up to 6 dB.

TABLE 6-20 A-GPS L1 MAXIMUM TIS/UHIS/PIGS LEVEL (IN dBm) REQUIREMENTS FOR THE PRIMARY MECHANICAL MODE FOR INTEGRATED DEVICES¹

Band	Positioning Method	SIB	FS		
			TIS	UHIS	PIGS
CDMA 800			TBD	TBD	TBD
CDMA 1900			TBD	TBD	TBD
CDMA 1700/2100			TBD	TBD	TBD
GSM 850	Control Plane / UE-Based	N/A	TBD	TBD	TBD
GSM 1900			TBD	TBD	TBD
UMTS 850			TBD	TBD	TBD
UMTS 1900			TBD	TBD	TBD
UMTS 1700/2100			TBD	TBD	TBD
LTE Band 71			TBD	TBD	TBD
LTE Band 12			TBD	TBD	TBD
LTE Band 17			TBD	TBD	TBD
LTE Band 13			TBD	TBD	TBD
LTE Band 14			TBD	TBD	TBD
LTE Band 26			TBD	TBD	TBD
LTE Band 5			TBD	TBD	TBD
LTE Band 70			TBD	TBD	TBD
LTE Band 4			TBD	TBD	TBD
LTE Band 66			TBD	TBD	TBD
LTE Band 2			TBD	TBD	TBD
LTE Band 25			TBD	TBD	TBD
LTE Band 30			TBD	TBD	TBD
LTE Band 7			TBD	TBD	TBD
LTE Band 41			TBD	TBD	TBD
LTE Band 48	TBD	TBD	TBD		

TABLE 6-20 A-GPS L1 MAXIMUM TIS/UHIS/PIGS LEVEL (IN DBM) REQUIREMENTS FOR THE PRIMARY MECHANICAL MODE FOR INTEGRATED DEVICES¹

Band	Positioning Method	SIB	FS		
			TIS	UHIS	PIGS
GSM 850	Control Plane / UE-Assisted	N/A	TBD	TBD	TBD
GSM 1900			TBD	TBD	TBD
UMTS 850			TBD	TBD	TBD
UMTS 1900			TBD	TBD	TBD
UMTS 1700/2100			TBD	TBD	TBD
LTE Band 71			TBD	TBD	TBD
LTE Band 12			TBD	TBD	TBD
LTE Band 17			TBD	TBD	TBD
LTE Band 13			TBD	TBD	TBD
LTE Band 14			TBD	TBD	TBD
LTE Band 26			TBD	TBD	TBD
LTE Band 5			TBD	TBD	TBD
LTE Band 70			TBD	TBD	TBD
LTE Band 4			TBD	TBD	TBD
LTE Band 66			TBD	TBD	TBD
LTE Band 2			TBD	TBD	TBD
LTE Band 25			TBD	TBD	TBD
LTE Band 30			TBD	TBD	TBD
LTE Band 7			TBD	TBD	TBD
LTE Band 41			TBD	TBD	TBD
LTE Band 48	TBD	TBD	TBD		

TABLE 6-20 A-GPS L1 MAXIMUM TIS/UHIS/PIGS LEVEL (IN DBM) REQUIREMENTS FOR THE PRIMARY MECHANICAL MODE FOR INTEGRATED DEVICES¹

Band	Positioning Method	SIB	FS		
			TIS	UHIS	PIGS
LTE Band 71	SUPL 2.0 / UE-Assisted	N/A	TBD	TBD	TBD
LTE Band 12			TBD	TBD	TBD
LTE Band 17			TBD	TBD	TBD
LTE Band 13			TBD	TBD	TBD
LTE Band 14			TBD	TBD	TBD
LTE Band 26			TBD	TBD	TBD
LTE Band 5			TBD	TBD	TBD
LTE Band 70			TBD	TBD	TBD
LTE Band 4			TBD	TBD	TBD
LTE Band 66			TBD	TBD	TBD
LTE Band 2			TBD	TBD	TBD
LTE Band 25			TBD	TBD	TBD
LTE Band 30			TBD	TBD	TBD
LTE Band 7			TBD	TBD	TBD
LTE Band 41			TBD	TBD	TBD
LTE Band 48			TBD	TBD	TBD
LTE Band 71	Control Plane / UE-Based	SIB8 and SIB16	TBD	TBD	TBD
LTE Band 12			TBD	TBD	TBD
LTE Band 17			TBD	TBD	TBD
LTE Band 13			TBD	TBD	TBD
LTE Band 14			TBD	TBD	TBD
LTE Band 26			TBD	TBD	TBD
LTE Band 5			TBD	TBD	TBD
LTE Band 70			TBD	TBD	TBD
LTE Band 4			TBD	TBD	TBD
LTE Band 66			TBD	TBD	TBD
LTE Band 2			TBD	TBD	TBD
LTE Band 25			TBD	TBD	TBD
LTE Band 30			TBD	TBD	TBD
LTE Band 7			TBD	TBD	TBD
LTE Band 41	TBD	TBD	TBD		
LTE Band 48	TBD	TBD	TBD		

TABLE 6-20 A-GPS L1 MAXIMUM TIS/UHIS/PIGS LEVEL (IN DBM) REQUIREMENTS FOR THE PRIMARY MECHANICAL MODE FOR INTEGRATED DEVICES¹

Band	Positioning Method	SIB	FS		
			TIS	UHIS	PIGS
LTE Band 71	Control Plane / UE-Assisted	SIB8 and SIB16	TBD	TBD	TBD
LTE Band 12			TBD	TBD	TBD
LTE Band 17			TBD	TBD	TBD
LTE Band 13			TBD	TBD	TBD
LTE Band 14			TBD	TBD	TBD
LTE Band 26			TBD	TBD	TBD
LTE Band 5			TBD	TBD	TBD
LTE Band 70			TBD	TBD	TBD
LTE Band 4			TBD	TBD	TBD
LTE Band 66			TBD	TBD	TBD
LTE Band 2			TBD	TBD	TBD
LTE Band 25			TBD	TBD	TBD
LTE Band 30			TBD	TBD	TBD
LTE Band 7			TBD	TBD	TBD
LTE Band 41			TBD	TBD	TBD
LTE Band 48			TBD	TBD	TBD
LTE Band 71	SUPL 2.0 / UE-Assisted	SIB8 and SIB16	TBD	TBD	TBD
LTE Band 12			TBD	TBD	TBD
LTE Band 17			TBD	TBD	TBD
LTE Band 13			TBD	TBD	TBD
LTE Band 14			TBD	TBD	TBD
LTE Band 26			TBD	TBD	TBD
LTE Band 5			TBD	TBD	TBD
LTE Band 70			TBD	TBD	TBD
LTE Band 4			TBD	TBD	TBD
LTE Band 66			TBD	TBD	TBD
LTE Band 2			TBD	TBD	TBD
LTE Band 25			TBD	TBD	TBD
LTE Band 30			TBD	TBD	TBD
LTE Band 7			TBD	TBD	TBD
LTE Band 41			TBD	TBD	TBD
LTE Band 48			TBD	TBD	TBD

Note 1: Primary Mechanical Mode refers to device configured in preferred mode per manufacturer instructions (typically depends on form factor and OEM input).

TABLE 6-21 A-GPS L1 MAXIMUM TIS LEVEL (IN dBm) REQUIREMENTS FOR THE PRIMARY MECHANICAL MODE FOR WRIST-WORN DEVICES¹

Band	Positioning Method	SIB	WL and WR
			TIS
LTE Band 71	Control Plane / UE-Based	N/A	TBD
LTE Band 12			TBD
LTE Band 17			TBD
LTE Band 13			TBD
LTE Band 14			TBD
LTE Band 26			TBD
LTE Band 5			TBD
LTE Band 70			TBD
LTE Band 4			TBD
LTE Band 66			TBD
LTE Band 2			TBD
LTE Band 25			TBD
LTE Band 30			TBD
LTE Band 7			TBD
LTE Band 41			TBD
LTE Band 48	TBD		
LTE Band 71	Control Plane / UE-Assisted	N/A	TBD
LTE Band 12			TBD
LTE Band 17			TBD
LTE Band 13			TBD
LTE Band 14			TBD
LTE Band 26			TBD
LTE Band 5			TBD
LTE Band 70			TBD
LTE Band 4			TBD
LTE Band 66			TBD
LTE Band 2			TBD
LTE Band 25			TBD
LTE Band 30			TBD
LTE Band 7			TBD
LTE Band 41			TBD
LTE Band 48	TBD		

TABLE 6-21 A-GPS L1 MAXIMUM TIS LEVEL (IN DBM) REQUIREMENTS FOR THE PRIMARY MECHANICAL MODE FOR WRIST-WORN DEVICES¹

Band	Positioning Method	SIB	WL and WR
			TIS
LTE Band 71	SUPL 2.0 / UE-Assisted	N/A	TBD
LTE Band 12			TBD
LTE Band 17			TBD
LTE Band 13			TBD
LTE Band 14			TBD
LTE Band 26			TBD
LTE Band 5			TBD
LTE Band 70			TBD
LTE Band 4			TBD
LTE Band 66			TBD
LTE Band 2			TBD
LTE Band 25			TBD
LTE Band 30			TBD
LTE Band 7			TBD
LTE Band 41			TBD
LTE Band 48			TBD
LTE Band 71	Control Plane / UE-Based	SIB8 and SIB16	TBD
LTE Band 12			TBD
LTE Band 17			TBD
LTE Band 13			TBD
LTE Band 14			TBD
LTE Band 26			TBD
LTE Band 5			TBD
LTE Band 70			TBD
LTE Band 4			TBD
LTE Band 66			TBD
LTE Band 2			TBD
LTE Band 25			TBD
LTE Band 30			TBD
LTE Band 7			TBD
LTE Band 41			TBD
LTE Band 48			TBD

TABLE 6-21 A-GPS L1 MAXIMUM TIS LEVEL (IN DBM) REQUIREMENTS FOR THE PRIMARY MECHANICAL MODE FOR WRIST-WORN DEVICES¹

Band	Positioning Method	SIB	WL and WR
			TIS
LTE Band 71	Control Plane / UE-Assisted	SIB8 and SIB16	TBD
LTE Band 12			TBD
LTE Band 17			TBD
LTE Band 13			TBD
LTE Band 14			TBD
LTE Band 26			TBD
LTE Band 5			TBD
LTE Band 70			TBD
LTE Band 4			TBD
LTE Band 66			TBD
LTE Band 2			TBD
LTE Band 25			TBD
LTE Band 30			TBD
LTE Band 7			TBD
LTE Band 41			TBD
LTE Band 48			TBD
LTE Band 71	SUPL 2.0 / UE-Assisted	SIB8 and SIB16	TBD
LTE Band 12			TBD
LTE Band 17			TBD
LTE Band 13			TBD
LTE Band 14			TBD
LTE Band 26			TBD
LTE Band 5			TBD
LTE Band 70			TBD
LTE Band 4			TBD
LTE Band 66			TBD
LTE Band 2			TBD
LTE Band 25			TBD
LTE Band 30			TBD
LTE Band 7			TBD
LTE Band 41			TBD
LTE Band 48			TBD

Note 1: Primary Mechanical Mode refers to device configured in preferred mode per manufacturer instructions (typically depends on form factor and OEM input).

As described earlier in this document, radiated performance evaluation of the EUT's A-GLONASS implementation is subject to a reduced set of tests.

TABLE 6-22 A-GLONASS WITH MAXIMUM TIS/UHIS/PIGS LEVEL (IN DBM) REQUIREMENTS FOR THE PRIMARY MECHANICAL MODE FOR DEVICES HELD TO THE HEAD FOR VOICE¹

Band	Positioning Method	SIB	Device Width (mm) ²	BHHL and BHHR			HL and HR		
				TIS	UHIS	PIGS	TIS	UHIS	PIGS
LTE Band 71	Control Plane / UE-Based	N/A	≤72	TBD	TBD	TBD	TBD	TBD	TBD
			>72	TBD	TBD	TBD	TBD	TBD	TBD
LTE Band 12			≤72	TBD	TBD	TBD	TBD	TBD	TBD
			>72	TBD	TBD	TBD	TBD	TBD	TBD
LTE Band 17			≤72	TBD	TBD	TBD	TBD	TBD	TBD
			>72	TBD	TBD	TBD	TBD	TBD	TBD
LTE Band 13			≤72	TBD	TBD	TBD	TBD	TBD	TBD
			>72	TBD	TBD	TBD	TBD	TBD	TBD
LTE Band 14			≤72	TBD	TBD	TBD	TBD	TBD	TBD
			>72	TBD	TBD	TBD	TBD	TBD	TBD
LTE Band 26			≤72	TBD	TBD	TBD	TBD	TBD	TBD
			>72	TBD	TBD	TBD	TBD	TBD	TBD
LTE Band 5			≤72	TBD	TBD	TBD	TBD	TBD	TBD
			>72	TBD	TBD	TBD	TBD	TBD	TBD
LTE Band 70			≤72	TBD	TBD	TBD	TBD	TBD	TBD
			>72	TBD	TBD	TBD	TBD	TBD	TBD
LTE Band 4			≤72	TBD	TBD	TBD	TBD	TBD	TBD
			>72	TBD	TBD	TBD	TBD	TBD	TBD
LTE Band 66			≤72	TBD	TBD	TBD	TBD	TBD	TBD
			>72	TBD	TBD	TBD	TBD	TBD	TBD
LTE Band 2	≤72	TBD	TBD	TBD	TBD	TBD	TBD		
	>72	TBD	TBD	TBD	TBD	TBD	TBD		
LTE Band 25	≤72	TBD	TBD	TBD	TBD	TBD	TBD		
	>72	TBD	TBD	TBD	TBD	TBD	TBD		
LTE Band 4	≤72	TBD	TBD	TBD	TBD	TBD	TBD		
	>72	TBD	TBD	TBD	TBD	TBD	TBD		
LTE Band 66	≤72	TBD	TBD	TBD	TBD	TBD	TBD		
	>72	TBD	TBD	TBD	TBD	TBD	TBD		
LTE Band 30	≤72	TBD	TBD	TBD	TBD	TBD	TBD		
	>72	TBD	TBD	TBD	TBD	TBD	TBD		
LTE Band 7	≤72	TBD	TBD	TBD	TBD	TBD	TBD		
	>72	TBD	TBD	TBD	TBD	TBD	TBD		
LTE Band 41	≤72	TBD	TBD	TBD	TBD	TBD	TBD		
	>72	TBD	TBD	TBD	TBD	TBD	TBD		
LTE Band 48	≤72	TBD	TBD	TBD	TBD	TBD	TBD		
	>72	TBD	TBD	TBD	TBD	TBD	TBD		

TABLE 6-22 A-GLONASS WITH MAXIMUM TIS/UHIS/PIGS LEVEL (IN DBM) REQUIREMENTS FOR THE PRIMARY MECHANICAL MODE FOR DEVICES HELD TO THE HEAD FOR VOICE¹

Band	Positioning Method	SIB	Device Width (mm) ²	BHHL and BHHR			HL and HR		
				TIS	UHIS	PIGS	TIS	UHIS	PIGS
LTE Band 71	Control Plane / UE-Assisted	N/A	≤72	TBD	TBD	TBD	TBD	TBD	TBD
			>72	TBD	TBD	TBD	TBD	TBD	TBD
LTE Band 12			≤72	TBD	TBD	TBD	TBD	TBD	TBD
			>72	TBD	TBD	TBD	TBD	TBD	TBD
LTE Band 17			≤72	TBD	TBD	TBD	TBD	TBD	TBD
			>72	TBD	TBD	TBD	TBD	TBD	TBD
LTE Band 13			≤72	TBD	TBD	TBD	TBD	TBD	TBD
			>72	TBD	TBD	TBD	TBD	TBD	TBD
LTE Band 14			≤72	TBD	TBD	TBD	TBD	TBD	TBD
			>72	TBD	TBD	TBD	TBD	TBD	TBD
LTE Band 26			≤72	TBD	TBD	TBD	TBD	TBD	TBD
			>72	TBD	TBD	TBD	TBD	TBD	TBD
LTE Band 5			≤72	TBD	TBD	TBD	TBD	TBD	TBD
			>72	TBD	TBD	TBD	TBD	TBD	TBD
LTE Band 70			≤72	TBD	TBD	TBD	TBD	TBD	TBD
			>72	TBD	TBD	TBD	TBD	TBD	TBD
LTE Band 4			≤72	TBD	TBD	TBD	TBD	TBD	TBD
			>72	TBD	TBD	TBD	TBD	TBD	TBD
LTE Band 66			≤72	TBD	TBD	TBD	TBD	TBD	TBD
			>72	TBD	TBD	TBD	TBD	TBD	TBD
LTE Band 2	≤72	TBD	TBD	TBD	TBD	TBD	TBD		
	>72	TBD	TBD	TBD	TBD	TBD	TBD		
LTE Band 25	≤72	TBD	TBD	TBD	TBD	TBD	TBD		
	>72	TBD	TBD	TBD	TBD	TBD	TBD		
LTE Band 30	≤72	TBD	TBD	TBD	TBD	TBD	TBD		
	>72	TBD	TBD	TBD	TBD	TBD	TBD		
LTE Band 7	≤72	TBD	TBD	TBD	TBD	TBD	TBD		
	>72	TBD	TBD	TBD	TBD	TBD	TBD		
LTE Band 41	≤72	TBD	TBD	TBD	TBD	TBD	TBD		
	>72	TBD	TBD	TBD	TBD	TBD	TBD		
LTE Band 48	≤72	TBD	TBD	TBD	TBD	TBD	TBD		
	>72	TBD	TBD	TBD	TBD	TBD	TBD		

TABLE 6-22 A-GLONASS WITH MAXIMUM TIS/UHIS/PIGS LEVEL (IN DBM) REQUIREMENTS FOR THE PRIMARY MECHANICAL MODE FOR DEVICES HELD TO THE HEAD FOR VOICE¹

Band	Positioning Method	SIB	Device Width (mm) ²	BHHL and BHHR			HL and HR		
				TIS	UHIS	PIGS	TIS	UHIS	PIGS
LTE Band 71	SUPL 2.0 / UE-Assisted	N/A	≤72	TBD	TBD	TBD	TBD	TBD	TBD
			>72	TBD	TBD	TBD	TBD	TBD	TBD
LTE Band 12			≤72	TBD	TBD	TBD	TBD	TBD	TBD
			>72	TBD	TBD	TBD	TBD	TBD	TBD
LTE Band 17			≤72	TBD	TBD	TBD	TBD	TBD	TBD
			>72	TBD	TBD	TBD	TBD	TBD	TBD
LTE Band 13			≤72	TBD	TBD	TBD	TBD	TBD	TBD
			>72	TBD	TBD	TBD	TBD	TBD	TBD
LTE Band 14			≤72	TBD	TBD	TBD	TBD	TBD	TBD
			>72	TBD	TBD	TBD	TBD	TBD	TBD
LTE Band 26			≤72	TBD	TBD	TBD	TBD	TBD	TBD
			>72	TBD	TBD	TBD	TBD	TBD	TBD
LTE Band 5			≤72	TBD	TBD	TBD	TBD	TBD	TBD
			>72	TBD	TBD	TBD	TBD	TBD	TBD
LTE Band 70			≤72	TBD	TBD	TBD	TBD	TBD	TBD
			>72	TBD	TBD	TBD	TBD	TBD	TBD
LTE Band 4			≤72	TBD	TBD	TBD	TBD	TBD	TBD
			>72	TBD	TBD	TBD	TBD	TBD	TBD
LTE Band 66			≤72	TBD	TBD	TBD	TBD	TBD	TBD
			>72	TBD	TBD	TBD	TBD	TBD	TBD
LTE Band 2	≤72	TBD	TBD	TBD	TBD	TBD	TBD		
	>72	TBD	TBD	TBD	TBD	TBD	TBD		
LTE Band 25	≤72	TBD	TBD	TBD	TBD	TBD	TBD		
	>72	TBD	TBD	TBD	TBD	TBD	TBD		
LTE Band 30	≤72	TBD	TBD	TBD	TBD	TBD	TBD		
	>72	TBD	TBD	TBD	TBD	TBD	TBD		
LTE Band 7	≤72	TBD	TBD	TBD	TBD	TBD	TBD		
	>72	TBD	TBD	TBD	TBD	TBD	TBD		
LTE Band 41	≤72	TBD	TBD	TBD	TBD	TBD	TBD		
	>72	TBD	TBD	TBD	TBD	TBD	TBD		
LTE Band 48	≤72	TBD	TBD	TBD	TBD	TBD	TBD		
	>72	TBD	TBD	TBD	TBD	TBD	TBD		

TABLE 6-22 A-GLONASS WITH MAXIMUM TIS/UHIS/PIGS LEVEL (IN DBM) REQUIREMENTS FOR THE PRIMARY MECHANICAL MODE FOR DEVICES HELD TO THE HEAD FOR VOICE¹

Band	Positioning Method	SIB	Device Width (mm) ²	BHHL and BHRH			HL and HR		
				TIS	UHIS	PIGS	TIS	UHIS	PIGS
LTE Band 71	Control Plane / UE-Based	SIB8 and SIB16	≤72	TBD	TBD	TBD	TBD	TBD	TBD
			>72	TBD	TBD	TBD	TBD	TBD	TBD
LTE Band 12			≤72	TBD	TBD	TBD	TBD	TBD	TBD
			>72	TBD	TBD	TBD	TBD	TBD	TBD
LTE Band 17			≤72	TBD	TBD	TBD	TBD	TBD	TBD
			>72	TBD	TBD	TBD	TBD	TBD	TBD
LTE Band 13			≤72	TBD	TBD	TBD	TBD	TBD	TBD
			>72	TBD	TBD	TBD	TBD	TBD	TBD
LTE Band 14			≤72	TBD	TBD	TBD	TBD	TBD	TBD
			>72	TBD	TBD	TBD	TBD	TBD	TBD
LTE Band 26			≤72	TBD	TBD	TBD	TBD	TBD	TBD
			>72	TBD	TBD	TBD	TBD	TBD	TBD
LTE Band 5			≤72	TBD	TBD	TBD	TBD	TBD	TBD
			>72	TBD	TBD	TBD	TBD	TBD	TBD
LTE Band 70			≤72	TBD	TBD	TBD	TBD	TBD	TBD
			>72	TBD	TBD	TBD	TBD	TBD	TBD
LTE Band 4			≤72	TBD	TBD	TBD	TBD	TBD	TBD
			>72	TBD	TBD	TBD	TBD	TBD	TBD
LTE Band 66			≤72	TBD	TBD	TBD	TBD	TBD	TBD
			>72	TBD	TBD	TBD	TBD	TBD	TBD
LTE Band 2	≤72	TBD	TBD	TBD	TBD	TBD	TBD		
	>72	TBD	TBD	TBD	TBD	TBD	TBD		
LTE Band 25	≤72	TBD	TBD	TBD	TBD	TBD	TBD		
	>72	TBD	TBD	TBD	TBD	TBD	TBD		
LTE Band 4	≤72	TBD	TBD	TBD	TBD	TBD	TBD		
	>72	TBD	TBD	TBD	TBD	TBD	TBD		
LTE Band 66	≤72	TBD	TBD	TBD	TBD	TBD	TBD		
	>72	TBD	TBD	TBD	TBD	TBD	TBD		
LTE Band 30	≤72	TBD	TBD	TBD	TBD	TBD	TBD		
	>72	TBD	TBD	TBD	TBD	TBD	TBD		
LTE Band 7	≤72	TBD	TBD	TBD	TBD	TBD	TBD		
	>72	TBD	TBD	TBD	TBD	TBD	TBD		
LTE Band 41	≤72	TBD	TBD	TBD	TBD	TBD	TBD		
	>72	TBD	TBD	TBD	TBD	TBD	TBD		
LTE Band 48	≤72	TBD	TBD	TBD	TBD	TBD	TBD		
	>72	TBD	TBD	TBD	TBD	TBD	TBD		

TABLE 6-22 A-GLONASS WITH MAXIMUM TIS/UHIS/PIGS LEVEL (IN DBM) REQUIREMENTS FOR THE PRIMARY MECHANICAL MODE FOR DEVICES HELD TO THE HEAD FOR VOICE¹

Band	Positioning Method	SIB	Device Width (mm) ²	BHHL and BHRH			HL and HR		
				TIS	UHIS	PIGS	TIS	UHIS	PIGS
LTE Band 71	Control Plane / UE-Assisted	SIB8 and SIB16	≤72	TBD	TBD	TBD	TBD	TBD	TBD
			>72	TBD	TBD	TBD	TBD	TBD	TBD
LTE Band 12			≤72	TBD	TBD	TBD	TBD	TBD	TBD
			>72	TBD	TBD	TBD	TBD	TBD	TBD
LTE Band 17			≤72	TBD	TBD	TBD	TBD	TBD	TBD
			>72	TBD	TBD	TBD	TBD	TBD	TBD
LTE Band 13			≤72	TBD	TBD	TBD	TBD	TBD	TBD
			>72	TBD	TBD	TBD	TBD	TBD	TBD
LTE Band 14			≤72	TBD	TBD	TBD	TBD	TBD	TBD
			>72	TBD	TBD	TBD	TBD	TBD	TBD
LTE Band 26			≤72	TBD	TBD	TBD	TBD	TBD	TBD
			>72	TBD	TBD	TBD	TBD	TBD	TBD
LTE Band 5			≤72	TBD	TBD	TBD	TBD	TBD	TBD
			>72	TBD	TBD	TBD	TBD	TBD	TBD
LTE Band 70			≤72	TBD	TBD	TBD	TBD	TBD	TBD
			>72	TBD	TBD	TBD	TBD	TBD	TBD
LTE Band 4			≤72	TBD	TBD	TBD	TBD	TBD	TBD
			>72	TBD	TBD	TBD	TBD	TBD	TBD
LTE Band 66			≤72	TBD	TBD	TBD	TBD	TBD	TBD
			>72	TBD	TBD	TBD	TBD	TBD	TBD
LTE Band 2	≤72	TBD	TBD	TBD	TBD	TBD	TBD		
	>72	TBD	TBD	TBD	TBD	TBD	TBD		
LTE Band 25	≤72	TBD	TBD	TBD	TBD	TBD	TBD		
	>72	TBD	TBD	TBD	TBD	TBD	TBD		
LTE Band 30	≤72	TBD	TBD	TBD	TBD	TBD	TBD		
	>72	TBD	TBD	TBD	TBD	TBD	TBD		
LTE Band 7	≤72	TBD	TBD	TBD	TBD	TBD	TBD		
	>72	TBD	TBD	TBD	TBD	TBD	TBD		
LTE Band 41	≤72	TBD	TBD	TBD	TBD	TBD	TBD		
	>72	TBD	TBD	TBD	TBD	TBD	TBD		
LTE Band 48	≤72	TBD	TBD	TBD	TBD	TBD	TBD		
	>72	TBD	TBD	TBD	TBD	TBD	TBD		

TABLE 6-22 A-GLONASS WITH MAXIMUM TIS/UHIS/PIGS LEVEL (IN DBM) REQUIREMENTS FOR THE PRIMARY MECHANICAL MODE FOR DEVICES HELD TO THE HEAD FOR VOICE¹

Band	Positioning Method	SIB	Device Width (mm) ²	BHHL and BHHR			HL and HR		
				TIS	UHIS	PIGS	TIS	UHIS	PIGS
LTE Band 71	SUPL 2.0 / UE-Assisted	SIB8 and SIB16	≤72	TBD	TBD	TBD	TBD	TBD	TBD
			>72	TBD	TBD	TBD	TBD	TBD	TBD
LTE Band 12			≤72	TBD	TBD	TBD	TBD	TBD	TBD
			>72	TBD	TBD	TBD	TBD	TBD	TBD
LTE Band 17			≤72	TBD	TBD	TBD	TBD	TBD	TBD
			>72	TBD	TBD	TBD	TBD	TBD	TBD
LTE Band 13			≤72	TBD	TBD	TBD	TBD	TBD	TBD
			>72	TBD	TBD	TBD	TBD	TBD	TBD
LTE Band 14			≤72	TBD	TBD	TBD	TBD	TBD	TBD
			>72	TBD	TBD	TBD	TBD	TBD	TBD
LTE Band 26			≤72	TBD	TBD	TBD	TBD	TBD	TBD
			>72	TBD	TBD	TBD	TBD	TBD	TBD
LTE Band 5			≤72	TBD	TBD	TBD	TBD	TBD	TBD
			>72	TBD	TBD	TBD	TBD	TBD	TBD
LTE Band 70			≤72	TBD	TBD	TBD	TBD	TBD	TBD
			>72	TBD	TBD	TBD	TBD	TBD	TBD
LTE Band 4			≤72	TBD	TBD	TBD	TBD	TBD	TBD
			>72	TBD	TBD	TBD	TBD	TBD	TBD
LTE Band 66			≤72	TBD	TBD	TBD	TBD	TBD	TBD
			>72	TBD	TBD	TBD	TBD	TBD	TBD
LTE Band 2	≤72	TBD	TBD	TBD	TBD	TBD	TBD		
	>72	TBD	TBD	TBD	TBD	TBD	TBD		
LTE Band 25	≤72	TBD	TBD	TBD	TBD	TBD	TBD		
	>72	TBD	TBD	TBD	TBD	TBD	TBD		
LTE Band 30	≤72	TBD	TBD	TBD	TBD	TBD	TBD		
	>72	TBD	TBD	TBD	TBD	TBD	TBD		
LTE Band 7	≤72	TBD	TBD	TBD	TBD	TBD	TBD		
	>72	TBD	TBD	TBD	TBD	TBD	TBD		
LTE Band 41	≤72	TBD	TBD	TBD	TBD	TBD	TBD		
	>72	TBD	TBD	TBD	TBD	TBD	TBD		
LTE Band 48	≤72	TBD	TBD	TBD	TBD	TBD	TBD		
	>72	TBD	TBD	TBD	TBD	TBD	TBD		

Note 1: Primary Mechanical Mode refers to device configured in preferred mode per manufacturer instructions (typically means antenna extended, fold or portrait slide open, but depends on form factor).
 Note 2: Differences between requirements for devices wider and narrower than 72 mm reflect observed differences in OTA performance with different hand phantoms of up to 6 dB.



TABLE 6-23 A-GLONASS with Maximum TIS/UHIS/PIGS Level (in dBm) Requirements for the Primary Mechanical Mode for Integrated Devices¹

Band	Positioning Method	SIB	FS		
			TIS	UHIS	PIGS
LTE Band 71	Control Plane / UE-Based	N/A	TBD	TBD	TBD
LTE Band 12			TBD	TBD	TBD
LTE Band 17			TBD	TBD	TBD
LTE Band 13			TBD	TBD	TBD
LTE Band 14			TBD	TBD	TBD
LTE Band 26			TBD	TBD	TBD
LTE Band 5			TBD	TBD	TBD
LTE Band 70			TBD	TBD	TBD
LTE Band 4			TBD	TBD	TBD
LTE Band 66			TBD	TBD	TBD
LTE Band 2			TBD	TBD	TBD
LTE Band 25			TBD	TBD	TBD
LTE Band 30			TBD	TBD	TBD
LTE Band 7			TBD	TBD	TBD
LTE Band 41			TBD	TBD	TBD
LTE Band 48			TBD	TBD	TBD
LTE Band 71	Control Plane / UE-Assisted	N/A	TBD	TBD	TBD
LTE Band 12			TBD	TBD	TBD
LTE Band 17			TBD	TBD	TBD
LTE Band 13			TBD	TBD	TBD
LTE Band 14			TBD	TBD	TBD
LTE Band 26			TBD	TBD	TBD
LTE Band 5			TBD	TBD	TBD
LTE Band 70			TBD	TBD	TBD
LTE Band 4			TBD	TBD	TBD
LTE Band 66			TBD	TBD	TBD
LTE Band 2			TBD	TBD	TBD
LTE Band 25			TBD	TBD	TBD
LTE Band 30			TBD	TBD	TBD
LTE Band 7			TBD	TBD	TBD
LTE Band 41			TBD	TBD	TBD
LTE Band 48			TBD	TBD	TBD

TABLE 6-23 A-GLONASS with Maximum TIS/UHIS/PIGS Level (in dBm) Requirements for the Primary Mechanical Mode for Integrated Devices¹

Band	Positioning Method	SIB	FS		
			TIS	UHIS	PIGS
LTE Band 71	SUPL 2.0 / UE-Assisted	N/A	TBD	TBD	TBD
LTE Band 12			TBD	TBD	TBD
LTE Band 17			TBD	TBD	TBD
LTE Band 13			TBD	TBD	TBD
LTE Band 14			TBD	TBD	TBD
LTE Band 26			TBD	TBD	TBD
LTE Band 5			TBD	TBD	TBD
LTE Band 70			TBD	TBD	TBD
LTE Band 4			TBD	TBD	TBD
LTE Band 66			TBD	TBD	TBD
LTE Band 2			TBD	TBD	TBD
LTE Band 25			TBD	TBD	TBD
LTE Band 30			TBD	TBD	TBD
LTE Band 7			TBD	TBD	TBD
LTE Band 41			TBD	TBD	TBD
LTE Band 48			TBD	TBD	TBD
LTE Band 71	Control Plane / UE-Based	SIB8 and SIB16	TBD	TBD	TBD
LTE Band 12			TBD	TBD	TBD
LTE Band 17			TBD	TBD	TBD
LTE Band 13			TBD	TBD	TBD
LTE Band 14			TBD	TBD	TBD
LTE Band 26			TBD	TBD	TBD
LTE Band 5			TBD	TBD	TBD
LTE Band 70			TBD	TBD	TBD
LTE Band 4			TBD	TBD	TBD
LTE Band 66			TBD	TBD	TBD
LTE Band 2			TBD	TBD	TBD
LTE Band 25			TBD	TBD	TBD
LTE Band 30			TBD	TBD	TBD
LTE Band 7			TBD	TBD	TBD
LTE Band 41			TBD	TBD	TBD
LTE Band 48			TBD	TBD	TBD

TABLE 6-23 A-GLONASS with Maximum TIS/UHIS/PIGS Level (in dBm) Requirements for the Primary Mechanical Mode for Integrated Devices¹

Band	Positioning Method	SIB	FS		
			TIS	UHIS	PIGS
LTE Band 71	Control Plane / UE-Assisted	SIB8 and SIB16	TBD	TBD	TBD
LTE Band 12			TBD	TBD	TBD
LTE Band 17			TBD	TBD	TBD
LTE Band 13			TBD	TBD	TBD
LTE Band 14			TBD	TBD	TBD
LTE Band 26			TBD	TBD	TBD
LTE Band 5			TBD	TBD	TBD
LTE Band 70			TBD	TBD	TBD
LTE Band 4			TBD	TBD	TBD
LTE Band 66			TBD	TBD	TBD
LTE Band 2			TBD	TBD	TBD
LTE Band 25			TBD	TBD	TBD
LTE Band 30			TBD	TBD	TBD
LTE Band 7			TBD	TBD	TBD
LTE Band 41			TBD	TBD	TBD
LTE Band 48			TBD	TBD	TBD
LTE Band 71	SUPL 2.0 / UE-Assisted	SIB8 and SIB16	TBD	TBD	TBD
LTE Band 12			TBD	TBD	TBD
LTE Band 17			TBD	TBD	TBD
LTE Band 13			TBD	TBD	TBD
LTE Band 14			TBD	TBD	TBD
LTE Band 26			TBD	TBD	TBD
LTE Band 5			TBD	TBD	TBD
LTE Band 70			TBD	TBD	TBD
LTE Band 4			TBD	TBD	TBD
LTE Band 66			TBD	TBD	TBD
LTE Band 2			TBD	TBD	TBD
LTE Band 25			TBD	TBD	TBD
LTE Band 30			TBD	TBD	TBD
LTE Band 7			TBD	TBD	TBD
LTE Band 41			TBD	TBD	TBD
LTE Band 48			TBD	TBD	TBD

Note 1: Primary Mechanical Mode refers to device configured in preferred mode per manufacturer instructions (typically depends on form factor and OEM input).

TABLE 6-24 A-GLONASS WITH MAXIMUM TIS LEVEL (IN dBm) REQUIREMENTS FOR THE PRIMARY MECHANICAL MODE FOR WRIST-WORN DEVICES¹

Band	Positioning Method	SIB	WL and WR
			TIS
LTE Band 71	Control Plane / UE-Based	N/A	TBD
LTE Band 12			TBD
LTE Band 17			TBD
LTE Band 13			TBD
LTE Band 14			TBD
LTE Band 26			TBD
LTE Band 5			TBD
LTE Band 70			TBD
LTE Band 4			TBD
LTE Band 66			TBD
LTE Band 2			TBD
LTE Band 25			TBD
LTE Band 30			TBD
LTE Band 7			TBD
LTE Band 41			TBD
LTE Band 48			TBD
LTE Band 71	Control Plane / UE-Assisted	N/A	TBD
LTE Band 12			TBD
LTE Band 17			TBD
LTE Band 13			TBD
LTE Band 14			TBD
LTE Band 26			TBD
LTE Band 5			TBD
LTE Band 70			TBD
LTE Band 4			TBD
LTE Band 66			TBD
LTE Band 2			TBD
LTE Band 25			TBD
LTE Band 30			TBD
LTE Band 7			TBD
LTE Band 41			TBD
LTE Band 48			TBD

TABLE 6-24 A-GLONASS WITH MAXIMUM TIS LEVEL (IN DBM) REQUIREMENTS FOR THE PRIMARY MECHANICAL MODE FOR WRIST-WORN DEVICES¹

Band	Positioning Method	SIB	WL and WR
			TIS
LTE Band 71	SUPL 2.0 / UE-Assisted	N/A	TBD
LTE Band 12			TBD
LTE Band 17			TBD
LTE Band 13			TBD
LTE Band 14			TBD
LTE Band 26			TBD
LTE Band 5			TBD
LTE Band 70			TBD
LTE Band 4			TBD
LTE Band 66			TBD
LTE Band 2			TBD
LTE Band 25			TBD
LTE Band 30			TBD
LTE Band 7			TBD
LTE Band 41			TBD
LTE Band 48			TBD
LTE Band 71	Control Plane / UE-Based	SIB8 and SIB16	TBD
LTE Band 12			TBD
LTE Band 17			TBD
LTE Band 13			TBD
LTE Band 14			TBD
LTE Band 26			TBD
LTE Band 5			TBD
LTE Band 70			TBD
LTE Band 4			TBD
LTE Band 66			TBD
LTE Band 2			TBD
LTE Band 25			TBD
LTE Band 30			TBD
LTE Band 7			TBD
LTE Band 41			TBD
LTE Band 48			TBD

TABLE 6-24 A-GLONASS WITH MAXIMUM TIS LEVEL (IN DBM) REQUIREMENTS FOR THE PRIMARY MECHANICAL MODE FOR WRIST-WORN DEVICES¹

Band	Positioning Method	SIB	WL and WR
			TIS
LTE Band 71	Control Plane / UE-Assisted	SIB8 and SIB16	TBD
LTE Band 12			TBD
LTE Band 17			TBD
LTE Band 13			TBD
LTE Band 14			TBD
LTE Band 26			TBD
LTE Band 5			TBD
LTE Band 70			TBD
LTE Band 4			TBD
LTE Band 66			TBD
LTE Band 2			TBD
LTE Band 25			TBD
LTE Band 30			TBD
LTE Band 7			TBD
LTE Band 41			TBD
LTE Band 48			TBD
LTE Band 71	SUPL 2.0 / UE-Assisted	SIB8 and SIB16	TBD
LTE Band 12			TBD
LTE Band 17			TBD
LTE Band 13			TBD
LTE Band 14			TBD
LTE Band 26			TBD
LTE Band 5			TBD
LTE Band 70			TBD
LTE Band 4			TBD
LTE Band 66			TBD
LTE Band 2			TBD
LTE Band 25			TBD
LTE Band 30			TBD
LTE Band 7			TBD
LTE Band 41			TBD
LTE Band 48			TBD

Note 1: Primary Mechanical Mode refers to device configured in preferred mode per manufacturer instructions (typically depends on form factor and OEM input).

6.14 FLO (Forward Link Only)

This section removed for V3.2.

6.15 Alternate Test Procedure for TIS

These alternate test procedures may significantly reduce the test time for TIS.

Use of these alternate test methods may require additional measurement uncertainty calculations, which are discussed in [Section 7.4](#).

6.15.1 Single Point Offset Test

This offset test procedure significantly reduces the test time for TIS for multi-protocol phones, which have more than one protocol in the same frequency band. This offset test procedure can be used to determine the offset in TIS between different protocols on equivalent channels, as well as between different error rates and/or data rates using the same protocol on the same channel. “Equivalent channels” assumes that the two channels are close enough in frequency that the pattern does not change. A single point offset test or a multi-point offset test may be used. This method may be used between stand-alone LTE and LTE CA or one LTE CA combination and another, when the same band, channel and RB allocation combination is evaluated in both LTE combinations if single point offset testing is allowed for the CA combination as specified in the operator CA combination priority list identified in [Appendix O.8](#).

This offset test procedure for TIS cannot be used with an antenna which uses a different physical radiator, or different aperture tuning (e.g. matching on parasitic elements or matching components on the ground or within the radiator) between the reference protocol and the protocol being evaluated. This offset test procedure cannot be used in this case because the antenna pattern will generally be different between the 2 protocols.

This offset test procedure for TIS can be used with an antenna which uses the same physical radiator, the same aperture tuning (e.g. matching on parasitic elements or matching components on the ground or within the radiator) but uses different impedance matching (e.g. matching components on the RF feed) between the reference protocol and the protocol being evaluated,

The manufacturer must declare to the ATL when antennas are implemented in such a way that this offset test procedure for TIS cannot be used, when single point offset tests are considered.

This offset test procedure also can be used only for protocols that utilize the same antenna combinations, for example, both protocols employ 2-branch diversity and the same pair of antennas. In this way, the C-TIS measured for one protocol can appropriately be scaled by the single point measurement for the other protocol.

It is recommended that voice digital protocols be given priority when doing full TIS measurements. For purposes of clarity for the following test procedure, test configuration A will be protocol/error rate/data rate for which a full TIS measurement is performed. Test configuration B will be the other protocol/error rate/data rate which will be tested using the single/multi-point radiated test.

This test sequence is repeated for each channel specified in the appropriate part of [Section 6](#). This test sequence shall be repeated for each EUT antenna configuration (free space, head and hand phantom,

hand phantom only, whip extended, whip retracted). The single point radiated sensitivity for both test configurations, the difference, and the calculated TIS for test configuration B shall be recorded.

The TIS test for test configuration A shall be completed first according to the appropriate part of [Section 6](#). After identifying the position and polarization for which the EUT has its maximum radiated sensitivity for one channel, the EUT should be placed in the same configuration. A radiated sensitivity measurement shall be first done in test configuration A according to the relevant procedures in [Section 6](#). If possible without touching the phone, initiate a hand-off or change to test configuration B at the equivalent channel. Otherwise, initiate a call in test configuration B and go to the equivalent channel. If the phone must be handled in order to initiate a call in test configuration B, then an additional repositioning uncertainty must be included to account for positioning repeatability. Following that, a radiated sensitivity measurement shall be done in test configuration B according to the relevant procedures in [Section 6](#). The two measurements shall be conducted as close in time as possible. The difference between these radiated tests shall then be used as an offset to the TIS for test configuration A in order to calculate the TIS for test configuration B.

6.15.2 Multi-point Offset Test

This offset method has similar benefits as the Single-Point Offset Test in [Section 6.15.1](#) and has the same restrictions as discussed in [Section 6.15.1](#).

Multiple positions and polarizations shall be predetermined for comparing test configurations A and B. The test positions and polarizations shall be selected such that they are spread relatively evenly in time throughout the TIS test and are spread relatively evenly in space over the sphere. While the TIS test for test configuration A is being performed, measurements for test configuration B will be performed at those predetermined positions and polarizations.

This is accomplished at those predetermined positions and polarizations by:

1. Measuring the radiated sensitivity for test configuration A,
2. Handing-off or changing to test configuration B,
3. Measuring the radiated sensitivity for test configuration B,
4. Handing-off or changing to test configuration A,
5. Continuing the TIS test until another predetermined position and polarization is to be tested, at which time, steps 1 to 5 are repeated.

The difference between the averages of the radiated sensitivities at the predetermined positions and polarizations shall then be used as an offset to the TIS for test configuration A in order to calculate the TIS for test configuration B.

Note: *More than 4 test positions/polarizations are recommended to keep the measurement uncertainty low.*

Note: *This test procedure using multiple test positions/polarizations will have lower uncertainty than the test procedure using a single test position/polarization.*

Note: *Using higher error rates and higher data rates can result in significantly faster test times for TIS.*

6.15.3 Alternate Test Procedure for GSM TIS Using Less Than Maximum TX Power

This alternate test procedure is specifically to allow the radiated RX sensitivity testing for the 3D pattern for the GSM protocol to be done at low TX power levels. The purpose of this allowance is to enable the battery to last longer during testing, which in turn enables more automated testing without having to change the battery. In particular, more testing can be accomplished unattended over night.

The same low TX power must be used during the entire TIS measurement. The next step involves using something similar to the single-point offset test procedure for TIS (in [Section 6.15.1](#)).

After identifying the position and polarization for which the EUT has its maximum radiated sensitivity for one channel, the EUT shall be placed in the same configuration. A radiated sensitivity measurement shall be first done using low TX power according to the relevant procedures in [Section 6](#). Without touching the phone, change the TX power to maximum. Then a radiated sensitivity measurement shall be done using maximum TX power according to the relevant procedures in [Section 6](#). The two measurements shall be conducted as close in time as possible. The difference between these radiated tests shall then be used as an offset to the TIS using low TX power in order to calculate the TIS with maximum TX power. This test sequence is repeated for each channel specified in the appropriate part of [Section 6](#). This test sequence shall be repeated for each EUT antenna configuration (free space, head and hand phantom, hand phantom only, whip extended, whip retracted). The single point radiated sensitivity at low and maximum TX power, the difference, and the calculated TIS using maximum TX power shall be recorded.

The additional uncertainty associated with the single point test would need to be included, as discussed in [Section 7.4](#).

Note: *Intermediate channel testing shall still be done using maximum TX power.*

6.15.4 Alternate TIS Test Procedure based on Receive Signal Strength (RSS)

This procedure details the methodology to be used when determining TIS using receive signal strength measurements. The test methodology will consist of four steps; RSS Pattern Measurement, RSS Pattern Linearization, Sensitivity Search, and Final TIS Calculation. The receive signal strength measurements that are available for any particular technology can vary. These may take the form of the following; RSSI (Receive Signal Strength Indicator), Carrier to Noise, Signal to Noise, Carrier to Interference, indicators based on code phase RMS error estimates, etc.

The Alternate TIS Test Procedure based on Receive Signal Strength shall not be used for cellular radio mode TIS testing.

6.15.4.1 RSS Pattern Measurement

The RSS Pattern Measurement shall utilize the same spherical measurement procedure as specified in [Section 6](#). A receive signal strength measurement shall be made at each polarization and point on the sphere. For the case when the received signal strength measurement is derived from the code phase RMS error, RSS is based on the estimated peak SNR at the UE, and computed from the code phase RMS error reported by the UE using the conversion:

$$20 \times \log_{10} \left(\frac{0.336 \times T_{chip}}{codephaseRMSError} \right)$$

where $T_{chip} = 293.052$ meters. The dynamic range of the RSS measurement shall be at least 20 dB and the minimum RSS measurement level shall be at least 10 dB above the noise floor of the measurement capability. If the RSS measurement for a particular polarization or point is below the dynamic range of the measurement capability or cannot be obtained, the data point shall be recorded with a value that is at least 20 dB below the lowest RSS measurement.

This receive signal strength measurement may be obtained in a number of different methods. The EUT may report the value via over-the-air messaging if the technology supports this mechanism. The EUT may record the values in non-volatile memory or RAM using an on-board application or test mode. The stored results would be extracted from the device via a data cable or via an over-the-air data connection supported by the EUT. If the results are extracted from the EUT after the test, there shall be a mechanism to reconcile the data with each position. Each measurement point shall be sufficiently averaged to reduce uncertainty to the value defined in the uncertainty budget.

It is recommended that the RSS pattern measurement be performed by reporting the RSS measurement via over-the-air messaging if the Base Station Simulator for the technology supports that mechanism. It is also recommended that the RSS measurements be made with the transmitter enabled via normal call processing, a special test mode, or an on-board application if the technology being tested normally supports the use of a reverse link.

6.15.4.2 RSS Pattern Linearization

The RSS pattern measurements shall be linearized. The peak in the RSS pattern shall be determined from the data collected in [Section 6.15.4.1](#). Re-position the EUT to the location of the maximum RSS. For GNSS, the chosen peak shall be in the upper hemisphere. As an alternative, the RSS linearization data may be obtained using a conducted test setup but the additional uncertainty shall be accounted for in the uncertainty budget.

Receive signal strength measurements shall be made at a maximum of 1 dB steps from the peak RSS measurement to at least 10 dB below the peak RSS measurement made in [Section 6.15.4.1](#). Care should be taken to avoid compression of the receiver or highly non-linear regions outside of the minimum linearization range specified above. These RSS measurements along with the corresponding signal level presented to the EUT shall be used to linearize the pattern data collected in [Section 6.15.4.1](#) such that the pattern data corresponds to a dB for dB change in the signal level presented to the EUT. RSS data that falls within the utilized step size shall be linearly interpolated. The interpolation shall be done in dB as opposed to in linear units. The linearization may be accomplished through various methods (see [Appendix E.1.1](#)) such as, but not limited to, Best Fit Straight Line methods or piecewise linear methods, as long as the proper linearization uncertainty has been accounted for in the uncertainty budget. RSS data that falls outside of the data set that was used to determine the linearization data shall be linearized to a line that is extended using the same slope as determined above for the last set of data points used for linearization at the edge of the data set.

This receive signal strength measurement may be obtained in a number of different methods. The EUT may report the value via over-the-air messaging if the technology supports this mechanism. The EUT may record the values in non-volatile memory or RAM using an on-board application or test mode. The stored results would be extracted from the device via a data cable or via an over-the-air data connection supported by the EUT. In either case, the method used shall be the same method that was used for the

RSS Pattern Measurement. Each measurement point shall be sufficiently averaged to reduce uncertainty to the value defined in the uncertainty budget.

It is recommended that the RSS pattern measurement be performed by reporting the RSS measurement via over-the-air messaging if the Base Station Simulator for the technology supports that mechanism. It is also recommended that the RSS measurements be made with the transmitter enabled via normal call processing, a special test mode, or an on-board application if the technology being tested normally supports the use of a reverse link. In either case, the method used shall be the same method that was used for the RSS Pattern Measurement.

6.15.4.3 Sensitivity Search

The peak in the RSS pattern shall be determined from the data collected in [Section 6.15.4.1](#). Re-position the EUT to the location of the maximum RSS. For GNSS, the chosen peak shall be in the upper hemisphere. Care should be taken not to disturb the EUT between the RSS Pattern Linearization step and this step. If the EUT is disturbed or repositioned, an appropriate repositioning uncertainty contribution shall be taken. If the RSS linearization data was obtained via conducted test methods, the additional repositioning uncertainty contribution has already been taken in [Section 6.15.4.2](#). For all cases, a repositioning uncertainty shall be taken due to the repositioning of the EUT after the pattern measurement in [Section 6.15.4.1](#). Perform a single-point sensitivity measurement for the particular technology in accordance with the measurement methodology specified for that technology.

The single-point sensitivity measurement may be obtained in a number of different methods. The sensitivity measurement may be performed via over-the-air messaging if the technology supports this mechanism. The EUT may record the error rates versus signal level in non-volatile memory or RAM using an on-board application or test mode. The stored results would be extracted from the device via a data cable or via an over-the-air data connection supported by the EUT.

If the technology being tested supports an EIS measurement via over-the-air messaging, the EIS measurement shall be made in this configuration with the transmitter set to maximum output power. If the technology being tested normally uses a reverse link to communicate to a server, the EIS measurement shall be made with the reverse link transmitter at maximum output power and enabled via normal call processing, a special test mode, or an on-board application.

The conducted sensitivity of the EUT shall also be measured at the antenna connector, if available, on all applicable protocols/frequencies. It is preferable that the EUT be the same as utilized for the RSS measurements. However, if the EUT does not readily support an antenna port for conducted measurements, a separate modified EUT may be provided for all conducted measurements. If no connector is available, the conducted sensitivity measurement is not required. Ideally, the sensitivity measurement will be performed with the same instrumentation in an equivalent configuration in order to minimize the measurement uncertainty involved. A different sensitivity measurement device may be used as long as any differences in absolute measurement accuracy are accounted for, either in corrections to the recorded sensitivity level or increased reported measurement uncertainty for the conducted measurement. Refer to [Appendix A.3](#) for more information on conducted sensitivity measurements and cabling setups.

6.15.4.4 RSS Data Format

This section specifies the format for EUT-generated RSS data used in the TIS pattern measurement process and other RSS-based tests under development. The EUT shall generate data in the specified format, either directly or via an intermediate data parser.

6.15.4.4.1 RSS Data Stored Locally on EUT

RSS data stored locally on the EUT during the pattern measurement process shall take the form of a comma-delimited ASCII text file. Each row or line of the file shall contain a single time stamped RSS measurement record. Each record shall terminate with a Carriage Return (decimal ASCII code 13) or Carriage Return/Line Feed combination (decimal ASCII codes 13+10).

Each measurement record or file line shall contain 6 fields as specified below separated by commas:

- **Date:** YYYY-MM-DD (e.g. "2008-03-15")
- **Time:** HH:MM:SS.000 (e.g. "16:20:01.568"). 24-hour format. The number of decimal points for fractional seconds shall depend on the available time resolution of the EUT's underlying technology.
- **Signal Source:** Integer index indicating the signal source for air interfaces using multiple signal sources, e.g., multiple satellite GPS L1 scenarios or multiple MBS beacon scenarios. In cases where signal sources have standard numerical identifiers, such as GPS L1 satellite IDs or MBS transmitter ID, this field shall contain that identifier. Otherwise, this field shall index starting from 0.
- **Antenna:** Integer index, starting from 0, indicating the antenna or receive chain for EUTs supporting multiple receivers. This value shall always be "0" for single-antenna devices.
- **RSS:** Received Signal Strength value (power in dBm; ratios in dB). For MBS, RSS is derived from the code phase RMS error, and it corresponds to:

$$20 \times \log_{10} \left(\frac{0.336 \times T_{chip}}{codephaseRMSError} \right)$$

where T_{chip} is 293.052 meters, $codephaseRMSError$ is the value in meters as specified in sub-clause 6.5.4.2 of the 3GPP 36.355 specification. The upper bound of the pseudo-range value given in the floating-point mapping is used.

- **Phase:** Phase angle of received signal in radians. For dual receiver LTE devices, this may be the relative phase between the two receivers. This value shall always be "0" if no phase information is provided.

The date and time fields must represent accurate elapsed time over the data collection period, but they are not required to be synchronized to a specific time-of-day reference. However, if these time stamps are not explicitly synchronized to the time reference used by the range equipment, the test solution developer must provide a mechanism to account for the time offset between EUT data and any range-specific data (e.g. position) collected simultaneously.

The first example below shows a data segment for a single-antenna device generating no phase information, with a single signal source. The second example shows a data segment for a dual-antenna device generating phase information, with a single signal source.

Example RSS Data Segment for a Single-antenna Device Providing No Phase Information, with One Signal Source

```
2008-03-15,16:20:01.568,0,0,-83.22,0
2008-03-15,16:20:01.771,0,0,-83.17,0
2008-03-15,16:20:01.964,0,0,-82.89,0
2008-03-15,16:20:02.167,0,0,-82.83,0
2008-03-15,16:20:02.362,0,0,-82.97,0
2008-03-15,16:20:02.566,0,0,-83.04,0
2008-03-15,16:20:02.770,0,0,-83.38,0
...
```

Example RSS Data Segment for a Dual-antenna Device Providing Phase Information, with One Signal Source

```
2008-03-15,16:20:01.568,0,0,-83.22,1.22972
2008-03-15,16:20:01.771,0,1,-88.83,2.54263
2008-03-15,16:20:01.964,0,0,-82.89,1.26694
2008-03-15,16:20:02.167,0,1,-89.41,2.52346
2008-03-15,16:20:02.362,0,0,-82.97,1.22856
2008-03-15,16:20:02.566,0,1,-89.62,2.46119
2008-03-15,16:20:02.770,0,0,-83.38,1.13947
...
```

6.15.4.4.2 RSS Data Reported via Over-The-Air Messaging

In the case where RSS data are reported via over-the-air messaging, data records shall be generated in a format identical to single lines of the data file format specified in [Section 6.15.4.4.1](#). Alternatively, the data may be transmitted by the EUT in a native format and converted to the specified format upon receipt by a data parsing application.

6.15.4.5 Error Rate Data Format

This section specifies the format for EUT-generated error rate data used in the sensitivity search process. The EUT shall generate data in the specified format, either directly or via an intermediate data parser. This format is not applicable for the current A-GNSS sensitivity search methodologies defined in [Section 6.13](#).

6.15.4.5.1 Error Rate Data Stored Locally on EUT

Error rate data stored locally on the EUT during the sensitivity search process shall take the form of a comma-delimited ASCII text file. Each row or line of the file shall contain a single time stamped

measurement record. Each record shall terminate with a Carriage Return (decimal ASCII code 13) or Carriage Return / Line Feed combination (decimal ASCII codes 13+10).

Each measurement record or file line shall contain 4 fields as specified below separated by commas:

- **Date:** YYYY-MM-DD (e.g. "2008-03-15")
- **Time:** HH:MM:SS.000 (e.g. "16:20:01.568"). 24-hour format. The number of decimal points for fractional seconds shall depend on the available time resolution of the EUT's underlying technology.
- **Errors:** Number of errors (bits, frames, packets, blocks, etc., depending on technology) or acquisition failure count for sensitivity definitions based on probability of acquisition.
- **Total:** Total observed number of bits, frames, packets, blocks, etc. or acquisition attempt count for sensitivity definitions based on probability of acquisition.

The date and time fields must represent accurate elapsed time over the data collection period, but they are not required to be synchronized to a specific time-of-day reference. However, if these time stamps are not explicitly synchronized to the time reference used by the range equipment, the test solution developer must provide a mechanism to account for the time offset between EUT data and any range-specific data (e.g., downlink power) collected simultaneously.

The example below shows an error rate data segment illustrating a hypothetical sensitivity search. Although not required, error rate data are typically reported at a fixed interval representing a fixed number of bits, frames, packets, acquisition attempts, etc.

Example Error Rate Data Segment

```
2008-03-15,21:40:01.568,0,602
2008-03-15,21:40:02.571,0,602
2008-03-15,21:40:03.564,0,602
2008-03-15,21:40:04.567,0,602
2008-03-15,21:40:05.562,1,602
2008-03-15,21:40:06.566,4,602
2008-03-15,21:40:07.570,17,602
...
```

6.15.4.5.2 Error Rate Data Reported via Over-The-Air Messaging

In the case where error rate data are reported via over-the-air messaging, data records shall be generated in a format identical to single lines of the data file format specified in [Section 6.15.4.5.1](#). Alternatively, the data may be transmitted by the EUT in a native format and converted to the specified format upon receipt by a data parsing application.

6.15.4.6 Final TIS Calculation

The final TIS and other spatially averaged quantities shall be calculated per [Appendix B.3.3](#), [Appendix B.3.5](#) and [Appendix B.3.6](#). In all cases, the linearized RSS values shall be used in the calculations.

6.15.5 TIS Measurement of Low Transmit Duty-Cycle Devices

An underlying assumption in the TIS test methodologies described in Sections 6.2, 6.4 through 6.10, and 6.20 of this document is that the EUT is capable of supporting a moderate to high transmit duty-cycle during normal operation. However, some EUTs are designed to transmit at full power for only a fraction of each hour, and as a result, typically have a very small heatsink for the power amplifier and a relatively low-capacity battery. Attempts to measure TIS using the current CTIA Certification methodology will, in many cases, cause the EUT to be damaged due to excessive heat.

This TIS test methodology described below applies only to EUTs which have insufficient power/thermal capacity to maintain the cellular link for at least 50% of the execution time of a single channel TRP or TIS test. It applies regardless of cellular radio mode, so it may be utilized, as applicable, for any EUT which would otherwise be tested according to Sections 6.2, 6.4 through 6.10, and 6.20 of this document.

1. If the EUT supports multiple cellular radio modes, determine which cellular radio mode includes the highest number of CTIA Certification normative bands. If more than one cellular radio mode supports the same number of bands, the highest-order supported cellular radio mode (e.g. LTE > UMTS) shall be selected to begin this test procedure.
2. Configure the network simulator so that the EUT output power will be approximately 10 dB below full output power. It's not necessary to set the uplink power to exactly 10 dB below full-power, it's only necessary to ensure that the EUT's uplink power setting on the network simulator is known and maintained through the execution of all subsequent tests, except as noted. The recommended device warm up time described in Clause 5 of this document should be applied to the reduced output power.
3. With the network simulator set to command the EUT to operate at a reduced output power, execute the TIS measurement process following the CTIA Certification procedure for the airlink under test in the selected band.
4. Once radiated sensitivity data from all measurement points have been collected for the selected band, determine the peaks in the EUT pattern per reference channel and orient the measurement antenna(s) to the peak associated with the low-frequency reference channel.
5. With the measurement antennas at the antenna pattern peak as described in Step 4, obtain a single radiated sensitivity (EIS) measurement on the band's first reference channel with reduced power. Document the radiated sensitivity at this measurement location for reduced power.
6. Command the EUT to transmit at full-power only long enough to obtain a single radiated sensitivity (EIS) measurement on the selected band's first reference channel. Document the radiated sensitivity at this measurement location for full power.
7. Repeat Steps 5 and 6 for the remaining two reference channels using the measurement antenna locations corresponding to the peak in the EUT's antenna pattern at each reference frequency determined earlier.
8. Once all EIS measurement data have been obtained, compare the EIS at the peak of the antenna pattern while operating at full power in each of the reference channels to the sensitivity measured at these measurement antenna positions (corresponding to the peak in the EUT's pattern) at reduced power. Document the reduction in radiated sensitivity (if any, in dB) between full and reduced power.
9. Calculate TRP and TIS for the EUT based on the reduced-power measurements. If the EIS of the device was found to be reduced in Step 8, apply this reduction (in dB) as a correction factor to the TIS measured at reduced power per reference channel in each band.
10. Intermediate-channel receiver sensitivity measurements shall be executed at full power using the methodology currently specified in the CTIA Certification OTA Test Plan. If the number of

intermediate channels is high, it may be necessary to allow the EUT to cool between measurements.

Repeat Steps 2 through 10 for each additional band and cellular radio mode supported by the device. If any subsequent cellular radio modes include bands not tested in Steps 2 through 10, follow a similar TIS measurement methodology for the previously-untested band(s) or cellular radio mode(s).

6.16 LTE Two Downlink Carrier Aggregation

The number and type of measurements required to support TIS performance evaluation shall be determined based on the CA specific test requirements for carrier aggregation testing as described in [Appendix O.8.2](#).

Several additional OTA sensitivity tests for CA OTA performance evaluation will be considered for future study, including:

- Relative sensitivity on intermediate channels

6.16.1 Test Procedure

This procedure only applies to two-downlink carrier aggregation with a single uplink carrier on the PCC. This procedure applies for both inter-band and intra-band cases.

Carrier Aggregation tests shall be executed as independent measurements of each CC. Therefore, CA testing as described in this section provides an assessment of radiated sensitivity on each CC with the EUT operating in the CA mode. A CA mode is defined as a specific combination of bands assigned to the PCC and SCCs used in carrier aggregation. The CA test methodology described in this section is not intended to provide a measurement of the EUT's aggregate throughput during CA operation.

CA sensitivity measurements shall be performed using data throughput on only one CC at a time as the measurement metric. The EUT's CA receiver sensitivity corresponds to the minimum downlink signal power required to provide a data throughput rate greater than or equal to 95% of the maximum throughput of the reference measurement channel on the tested CC. The CA testing will be executed using C-TIS, with all receivers active, following the guidance in the previous portions of [Section 6](#). Refer to [Appendix A](#) for set-up illustrations.

To remain consistent with 3GPP core specifications, the LTE system simulator and EUT shall be configured per 3GPP 36.521-1, section 7.3A.3 (Reference Sensitivity Level for CA (inter-band DL CA without UL CA) when executing tests against the inter-band CA combinations in [Table 6-25](#). Intra-band CA combinations in [Table 6-25](#) require the LTE system simulator and EUT to be configured per 3GPP 36.521-1, Clause 7.3A.2 (intra-band contiguous DL CA without UL CA) or Clause 7.3A.4 (intra-band non-contiguous DL CA without UL CA). In each case, the defaults specified in 3GPP TS 36.521-1 and 3GPP TS 36.508 shall be used as applicable. For a given downlink RF power level, throughput shall be measured using the test procedure in section 7.3 of 3GPP TS 36.521-1 using the downlink and uplink reference measurement channels defined in Annexes A.2.2, A.2.3, and A.3.2 of 3GPP TS 36.521-1 and [Table 6-25](#). For LTE Band 13, the settings in [Table 6-25](#) shall take precedence over the settings in Annexes A.2.2, A.2.3, and A.3.2 of 3GPP TS 36.521-1.

The LTE system simulator shall send continuous uplink power control "up" commands to the EUT to ensure the EUT's transmitter is operating at maximum output power during the sensitivity searches of the PCC or the SCC. As the 3GPP reference does not make any mention of p-Max, nor is p-Max included in the default message content defined in 3GPP TS 36.508, p-Max shall not be signaled during attach procedures or during measurements.

When any SCC is the CC under test, the PCC is used only to provide control of the EUT, and therefore a calibrated downlink power level to the EUT is not required. Labs may assign any desired antenna to provide support for the untested CC so long as the selected antenna does not interfere with the tested CC measurements. Labs are encouraged to confirm that the eNodeB's PCC output power and antenna placement is sufficient to maintain a reliable radio link to the EUT in advance of beginning the execution of a CA TIS test on the SCC. The DL of the untested CC should be configured to not impair the tested CC. When executing intra-band CA TIS tests, it's recommended that the DL power on the untested CC be limited in order to minimize the potential for interference from the test system to the tested CC.

The downlink power step size of the CA component carrier under test shall be no more than 0.5 dB when the RF power level is near the LTE sensitivity level. The minimum RF power level resulting in a data throughput rate greater than or equal to 95% of the maximum throughput of the reference measurement channel shall be recorded as the downlink power level corresponding to the 95% throughput percentage (the data throughput rate is as defined in section 7.3A.2, 7.3A.3 or 7.3A4 of 3GPP TS 36.521-1 as applicable). Care must be taken to ensure that the duration of the throughput measurement is sufficient to achieve statistical significance according to Annex G.2 of 3GPP TS 36.521-1. The downlink signal level for each EUT test condition shall be recorded for integration pursuant to [Appendix B.3](#) to give a single figure of merit referred to as Total Isotropic Sensitivity (TIS).

Typically, the maximum deviation in receive level measurements from peak to null of any one channel does not exceed 30 dB. Therefore, the test facility may elect to initiate each sensitivity measurement starting with the base station power set 30 dB above the lowest sensitivity level measured in order to reduce the time required to search for the sensitivity floor. For points where this setting is below the target sensitivity level, the sensitivity may be considered negligible for that location and the initial value used in place of an actual measurement. TIS for the PCC and SCC shall be fully measured as described above and calculated pursuant to [Appendix B.3](#).

In order to reduce the need for communication tester upgrades or additions, testing LTE CA 2 DL combinations in stand-alone LTE is allowed under certain conditions as long as the antenna tuning is set according to the CA 2 DL combination that is being evaluated. The PCC TIS for a 2 DL CA combination may be tested in stand-alone LTE mode with the antenna tuned for operation in the 2 DL CA combination. The SCC TIS for a 2 DL CA combination may also be tested in stand-alone LTE mode with the antenna tuned for operation in the 2 DL CA combination as long as the SCC is not susceptible to harmonic, intermodulation or self-desense interference from the PCC TX.

For example, when evaluating an interband 2 DL CA case, CA_xA-yA, where x and y are the LTE bands and the PCC is in LTE x, then the following tests are permitted:

1. TIS for x in CA xA-yA may be tested in stand-alone LTE x with the antenna tuned for operation in CA_xA-yA.
2. TIS for y in CA xA-yA may be tested in stand-alone LTE y with the antenna tuned for operation in CA_xA-yA when LTE y is not susceptible harmonic, intermodulation or self-desense interference from LTE x.

Device manufacturers using dynamically tuned antennas should in general have a method of altering the antenna tuning in order to do the necessary antenna tuning optimization during the R&D phase. In general, the settings for the antenna tuner are stored in a tuning file. Consequently, the antenna tuning can be modified by writing a different tuning file into the device. All the stand-alone LTE bands could be tested using the normal tuning file. A second tuning file for testing the 2 DL CA modes could be created where the antenna tuner settings for the stand-alone LTE bands are changed to the antenna tuner settings for the associated 2 DL CA mode.

The following LTE bands have channels that can only be tested in DL CA mode: 29

TABLE 6-25 LTE CARRIER AGGREGATION MODE (2 DOWNLINK CARRIERS, 1 UPLINK CARRIER) TIS MEASUREMENTS TABLE FOR THE PRIMARY MECHANICAL MODE¹

Carrier Aggregation Combination	Primary Component Carrier (PCC) Band	Secondary Component Carrier (SCC) Band	PCC BW (MHz)	SCC BW (MHz)	PCC Channel	SCC Channel	PCC UL RB Allocation	PCC DL RB Allocation	SCC DL RB Allocation
CA_2A-2A ^{2,3}	2	2	10	10	650	900	50 RB with RBstart=0	50 RB with RBstart=0	50 RB with RBstart=0
					800 ⁴	650	32 RB with RBstart=18	50 RB with RBstart=0	50 RB with RBstart=0
					900	1150	50 RB with RBstart=0	50 RB with RBstart=0	50 RB with RBstart=0
					1150	650	12 RB with RBstart=38	50 RB with RBstart=0	50 RB with RBstart=0
CA_2A-4A ⁵	2	4	10	10	650	2000	50 RB with RBstart=0	50 RB with RBstart=0	50 RB with RBstart=0
					900	2175	50 RB with RBstart=0	50 RB with RBstart=0	50 RB with RBstart=0
					1150	2350	50 RB with RBstart=0	50 RB with RBstart=0	50 RB with RBstart=0
CA_2A-5A	2	5	10	10	650	2450	50 RB with RBstart=0	50 RB with RBstart=0	50 RB with RBstart=0
					900	2525	50 RB with RBstart=0	50 RB with RBstart=0	50 RB with RBstart=0
					1150	2600	50 RB with RBstart=0	50 RB with RBstart=0	50 RB with RBstart=0
CA_2A-12A ⁶	2	12	10	5	650	5035	50 RB with RBstart=0	50 RB with RBstart=0	25 RB with RBstart=0
					900	5095	50 RB with RBstart=0	50 RB with RBstart=0	25 RB with RBstart=0
					1150	5155	50 RB with RBstart=0	50 RB with RBstart=0	25 RB with RBstart=0
CA_2A-13A	2	13	10	10	650	5230	50 RB with RBstart=0	50 RB with RBstart=0	50 RB with RBstart=0
					900	5230	50 RB with RBstart=0	50 RB with RBstart=0	50 RB with RBstart=0
					1150	5230	50 RB with RBstart=0	50 RB with RBstart=0	50 RB with RBstart=0
CA_2A-17A ⁶	2	17	10	10	650	5800	50 RB with RBstart=0	50 RB with RBstart=0	50 RB with RBstart=0
					900	5800	50 RB with RBstart=0	50 RB with RBstart=0	50 RB with RBstart=0
					1150	5800	50 RB with RBstart=0	50 RB with RBstart=0	50 RB with RBstart=0

TABLE 6-25 LTE CARRIER AGGREGATION MODE (2 DOWNLINK CARRIERS, 1 UPLINK CARRIER) TIS
MEASUREMENTS TABLE FOR THE PRIMARY MECHANICAL MODE¹

Carrier Aggregation Combination	Primary Component Carrier (PCC) Band	Secondary Component Carrier (SCC) Band	PCC BW (MHz)	SCC BW (MHz)	PCC Channel	SCC Channel	PCC UL RB Allocation	PCC DL RB Allocation	SCC DL RB Allocation
CA_2A-29A	2	29	10	10	650	9720	50 RB with RBstart=0	50 RB with RBstart=0	50 RB with RBstart=0
					900	9720	50 RB with RBstart=0	50 RB with RBstart=0	50 RB with RBstart=0
					1150	9720	50 RB with RBstart=0	50 RB with RBstart=0	50 RB with RBstart=0
CA_2A-30A	2	30	10	10	650	9820	50 RB with RBstart=0	50 RB with RBstart=0	50 RB with RBstart=0
					900	9820	50 RB with RBstart=0	50 RB with RBstart=0	50 RB with RBstart=0
					1150	9820	50 RB with RBstart=0	50 RB with RBstart=0	50 RB with RBstart=0
CA_2A-48A	2	48	10	10	650	55290	50 RB with RBstart=0	50 RB with RBstart=0	50 RB with RBstart=0
					900	55990	50 RB with RBstart=0	50 RB with RBstart=0	50 RB with RBstart=0
					1150	56690	50 RB with RBstart=0	50 RB with RBstart=0	50 RB with RBstart=0
CA_2A-66A ⁵	2	66	10	10	650	66486	50 RB with RBstart=0	50 RB with RBstart=0	50 RB with RBstart=0
					900	66786	50 RB with RBstart=0	50 RB with RBstart=0	50 RB with RBstart=0
					900	67086 ⁷	50 RB with RBstart=0	50 RB with RBstart=0	50 RB with RBstart=0
					1150	67286	50 RB with RBstart=0	50 RB with RBstart=0	50 RB with RBstart=0
CA_4A-2A ⁵	4	2	10	10	2000	650	50 RB with RBstart=0	50 RB with RBstart=0	50 RB with RBstart=0
					2175	900	50 RB with RBstart=0	50 RB with RBstart=0	50 RB with RBstart=0
					2350	1150	50 RB with RBstart=0	50 RB with RBstart=0	50 RB with RBstart=0
CA_4A-4A ⁵	4	4	10	10	2000	2175	50 RB with RBstart=0	50 RB with RBstart=0	50 RB with RBstart=0
					2175	2350	50 RB with RBstart=0	50 RB with RBstart=0	50 RB with RBstart=0
					2350	2000	50 RB with RBstart=0	50 RB with RBstart=0	50 RB with RBstart=0
CA_4A-5A ⁵	4	5	10	10	2000	2450	50 RB with RBstart=0	50 RB with RBstart=0	50 RB with RBstart=0
					2175	2525	50 RB with RBstart=0	50 RB with RBstart=0	50 RB with RBstart=0
					2350	2600	50 RB with RBstart=0	50 RB with RBstart=0	50 RB with RBstart=0

TABLE 6-25 LTE CARRIER AGGREGATION MODE (2 DOWNLINK CARRIERS, 1 UPLINK CARRIER) TIS MEASUREMENTS TABLE FOR THE PRIMARY MECHANICAL MODE¹

Carrier Aggregation Combination	Primary Component Carrier (PCC) Band	Secondary Component Carrier (SCC) Band	PCC BW (MHz)	SCC BW (MHz)	PCC Channel	SCC Channel	PCC UL RB Allocation	PCC DL RB Allocation	SCC DL RB Allocation
CA_4A-12A ^{5,6}	4	12	10	5	2000	5035	50 RB with RBstart=0	50 RB with RBstart=0	25 RB with RBstart=0
					2175	5095	50 RB with RBstart=0	50 RB with RBstart=0	25 RB with RBstart=0
					2350	5155	50 RB with RBstart=0	50 RB with RBstart=0	25 RB with RBstart=0
CA_4A-13A ⁵	4	13	10	10	2000	5230	50 RB with RBstart=0	50 RB with RBstart=0	50 RB with RBstart=0
					2175	5230	50 RB with RBstart=0	50 RB with RBstart=0	50 RB with RBstart=0
					2350	5230	50 RB with RBstart=0	50 RB with RBstart=0	50 RB with RBstart=0
CA_4A-17A ^{5,6}	4	17	10	10	2000	5800	50 RB with RBstart=0	50 RB with RBstart=0	50 RB with RBstart=0
					2175	5800	50 RB with RBstart=0	50 RB with RBstart=0	50 RB with RBstart=0
					2350	5800	50 RB with RBstart=0	50 RB with RBstart=0	50 RB with RBstart=0
CA_4A-29A ⁵	4	29	10	10	2000	9720	50 RB with RBstart=0	50 RB with RBstart=0	50 RB with RBstart=0
					2175	9720	50 RB with RBstart=0	50 RB with RBstart=0	50 RB with RBstart=0
					2350	9720	50 RB with RBstart=0	50 RB with RBstart=0	50 RB with RBstart=0
CA_4A-30A ⁵	4	30	10	10	2000	9820	50 RB with RBstart=0	50 RB with RBstart=0	50 RB with RBstart=0
					2175	9820	50 RB with RBstart=0	50 RB with RBstart=0	50 RB with RBstart=0
					2350	9820	50 RB with RBstart=0	50 RB with RBstart=0	50 RB with RBstart=0
CA_5A-2A	5	2	10	10	2450	650	25 RB with RBstart=25	50 RB with RBstart=0	50 RB with RBstart=0
					2525	900	25 RB with RBstart=25	50 RB with RBstart=0	50 RB with RBstart=0
					2600	1150	25 RB with RBstart=25	50 RB with RBstart=0	50 RB with RBstart=0
CA_5A-4A ⁵	5	4	10	10	2450	2000	25 RB with RBstart=25	50 RB with RBstart=0	50 RB with RBstart=0
					2525	2175	25 RB with RBstart=25	50 RB with RBstart=0	50 RB with RBstart=0
					2600	2350	25 RB with RBstart=25	50 RB with RBstart=0	50 RB with RBstart=0

TABLE 6-25 LTE CARRIER AGGREGATION MODE (2 DOWNLINK CARRIERS, 1 UPLINK CARRIER) TIS MEASUREMENTS TABLE FOR THE PRIMARY MECHANICAL MODE¹

Carrier Aggregation Combination	Primary Component Carrier (PCC) Band	Secondary Component Carrier (SCC) Band	PCC BW (MHz)	SCC BW (MHz)	PCC Channel	SCC Channel	PCC UL RB Allocation	PCC DL RB Allocation	SCC DL RB Allocation
CA_5B ²	5	5	10	10	2450	2549	25 RB with RBstart=25	50 RB with RBstart=0	50 RB with RBstart=0
					2600	2501	25 RB with RBstart=25	50 RB with RBstart=0	50 RB with RBstart=0
CA_5A-5A ^{2,8,9}	5	5	5	5	2425	2525	25 RB with RBstart=0	25 RB with RBstart=0	25 RB with RBstart=0
					2525	2625	25 RB with RBstart=0	25 RB with RBstart=0	25 RB with RBstart=0
					2625	2425	12 RB with RBstart=13	25 RB with RBstart=0	25 RB with RBstart=0
					2425 ¹⁰	2625	25 RB with RBstart=0	25 RB with RBstart=0	25 RB with RBstart=0
CA_5A-30A	5	30	10	10	2450	9820	25 RB with RBstart=25	50 RB with RBstart=0	50 RB with RBstart=0
					2525	9820	25 RB with RBstart=25	50 RB with RBstart=0	50 RB with RBstart=0
					2600	9820	25 RB with RBstart=25	50 RB with RBstart=0	50 RB with RBstart=0
CA_5A-48A	5	48	10	10	2450	55290	25 RB with RBstart=25	50 RB with RBstart=0	50 RB with RBstart=0
					2525	55990	25 RB with RBstart=25	50 RB with RBstart=0	50 RB with RBstart=0
					2600	56690	25 RB with RBstart=25	50 RB with RBstart=0	50 RB with RBstart=0
CA_5A-66A ⁵	5	66	10	10	2450	66486	25 RB with RBstart=25	50 RB with RBstart=0	50 RB with RBstart=0
					2525	66786	25 RB with RBstart=25	50 RB with RBstart=0	50 RB with RBstart=0
					2525	67086 ⁷	25 RB with RBstart=25	50 RB with RBstart=0	50 RB with RBstart=0
					2600	67286	25 RB with RBstart=25	50 RB with RBstart=0	50 RB with RBstart=0
CA_12A-2A ⁶	12	2	5	10	5035	650	20 RB with RBstart=5	25 RB with RBstart=0	50 RB with RBstart=0
					5095	900	20 RB with RBstart=5	25 RB with RBstart=0	50 RB with RBstart=0
					5155	1150	20 RB with RBstart=5	25 RB with RBstart=0	50 RB with RBstart=0
CA_12A-4A ^{2,5,6}	12	4	5	10	5035	2000	20 RB with RBstart=5	25 RB with RBstart=0	50 RB with RBstart=0
					5095	2175	20 RB with RBstart=5	25 RB with RBstart=0	50 RB with RBstart=0
					5155	2350	20 RB with RBstart=5	25 RB with RBstart=0	50 RB with RBstart=0

TABLE 6-25 LTE CARRIER AGGREGATION MODE (2 DOWNLINK CARRIERS, 1 UPLINK CARRIER) TIS MEASUREMENTS TABLE FOR THE PRIMARY MECHANICAL MODE¹

Carrier Aggregation Combination	Primary Component Carrier (PCC) Band	Secondary Component Carrier (SCC) Band	PCC BW (MHz)	SCC BW (MHz)	PCC Channel	SCC Channel	PCC UL RB Allocation	PCC DL RB Allocation	SCC DL RB Allocation
CA_12A-30A	12	30	5	10	5035	9820	20 RB with RBstart=5	25 RB with RBstart=0	50 RB with RBstart=0
					5095	9820	20 RB with RBstart=5	25 RB with RBstart=0	50 RB with RBstart=0
					5155	9820	20 RB with RBstart=5	25 RB with RBstart=0	50 RB with RBstart=0
CA_12A-66A ^{2,5,6}	12	66	5	10	5035	66486	20 RB with RBstart=5	25 RB with RBstart=0	50 RB with RBstart=0
					5095	66786	20 RB with RBstart=5	25 RB with RBstart=0	50 RB with RBstart=0
					5095	67086 ⁷	20 RB with RBstart=5	25 RB with RBstart=0	50 RB with RBstart=0
					5155	67286	20 RB with RBstart=5	25 RB with RBstart=0	50 RB with RBstart=0
CA_13A-2A	13	2	10	10	5230	650	15 RB with RBstart=0	50 RB with RBstart=0	50 RB with RBstart=0
					5230	900	15 RB with RBstart=0	50 RB with RBstart=0	50 RB with RBstart=0
					5230	1150	15 RB with RBstart=0	50 RB with RBstart=0	50 RB with RBstart=0
CA_13A-4A ⁵	13	4	10	10	5230	2000	15 RB with RBstart=0	50 RB with RBstart=0	50 RB with RBstart=0
					5230	2175	15 RB with RBstart=0	50 RB with RBstart=0	50 RB with RBstart=0
					5230	2350	15 RB with RBstart=0	50 RB with RBstart=0	50 RB with RBstart=0
CA_13A-48A	13	48	10	10	5230	55290	15 RB with RBstart=0	50 RB with RBstart=0	50 RB with RBstart=0
					5230	55990	15 RB with RBstart=0	50 RB with RBstart=0	50 RB with RBstart=0
					5230	56690	15 RB with RBstart=0	50 RB with RBstart=0	50 RB with RBstart=0
CA_13A-66A ⁵	13	66	10	10	5230	66486	15 RB with RBstart=0	50 RB with RBstart=0	50 RB with RBstart=0
					5230	66786	15 RB with RBstart=0	50 RB with RBstart=0	50 RB with RBstart=0
					5230	67086 ⁷	15 RB with RBstart=0	50 RB with RBstart=0	50 RB with RBstart=0
					5230	67286	15 RB with RBstart=0	50 RB with RBstart=0	50 RB with RBstart=0

TABLE 6-25 LTE CARRIER AGGREGATION MODE (2 DOWNLINK CARRIERS, 1 UPLINK CARRIER) TIS MEASUREMENTS TABLE FOR THE PRIMARY MECHANICAL MODE¹

Carrier Aggregation Combination	Primary Component Carrier (PCC) Band	Secondary Component Carrier (SCC) Band	PCC BW (MHz)	SCC BW (MHz)	PCC Channel	SCC Channel	PCC UL RB Allocation	PCC DL RB Allocation	SCC DL RB Allocation
CA_17A-2A ⁶	17	2	10	10	5800	650	20 RB with RBstart=30	50 RB with RBstart=0	50 RB with RBstart=0
					5800	900	20 RB with RBstart=30	50 RB with RBstart=0	50 RB with RBstart=0
					5800	1150	20 RB with RBstart=30	50 RB with RBstart=0	50 RB with RBstart=0
CA_17A-4A ^{2,5,6}	17	4	10	10	5800	2000	20 RB with RBstart=30	50 RB with RBstart=0	50 RB with RBstart=0
					5800	2175	20 RB with RBstart=30	50 RB with RBstart=0	50 RB with RBstart=0
					5800	2350	20 RB with RBstart=30	50 RB with RBstart=0	50 RB with RBstart=0
CA_17A-66A ^{2,5,6}	17	66	10	10	5800	66486	20 RB with RBstart=30	50 RB with RBstart=0	50 RB with RBstart=0
					5800	66786	20 RB with RBstart=30	50 RB with RBstart=0	50 RB with RBstart=0
					5800	67086 ⁷	20 RB with RBstart=30	50 RB with RBstart=0	50 RB with RBstart=0
					5800	67286	20 RB with RBstart=30	50 RB with RBstart=0	50 RB with RBstart=0
CA_25A-25A	25	25	5	5	8065	8665	25 RB with RBstart=0	25 RB with RBstart=0	25 RB with RBstart=0
					8365	8665	25 RB with RBstart=0	25 RB with RBstart=0	25 RB with RBstart=0
					8665	8065	10 RB with RBstart=15	25 RB with RBstart=0	25 RB with RBstart=0
CA_25A-26A	25	26	5	5	8065	8715	25 RB with RBstart=0	25 RB with RBstart=0	25 RB with RBstart=0
					8365	8865	25 RB with RBstart=0	25 RB with RBstart=0	25 RB with RBstart=0
					8665	9015	25 RB with RBstart=0	25 RB with RBstart=0	25 RB with RBstart=0
CA_25A-41A	25	41	5	20	8065	39750	25 RB with RBstart=0	25 RB with RBstart=0	100 RB with RBstart=0
					8365	40620	25 RB with RBstart=0	25 RB with RBstart=0	100 RB with RBstart=0
					8665	41490	25 RB with RBstart=0	25 RB with RBstart=0	100 RB with RBstart=0
CA_26A-25A	26	25	5	5	8715	8065	25 RB with RBstart=0	25 RB with RBstart=0	25 RB with RBstart=0
					8865	8365	25 RB with RBstart=0	25 RB with RBstart=0	25 RB with RBstart=0
					9015	8665	25 RB with RBstart=0	25 RB with RBstart=0	25 RB with RBstart=0

TABLE 6-25 LTE CARRIER AGGREGATION MODE (2 DOWNLINK CARRIERS, 1 UPLINK CARRIER) TIS MEASUREMENTS TABLE FOR THE PRIMARY MECHANICAL MODE¹

Carrier Aggregation Combination	Primary Component Carrier (PCC) Band	Secondary Component Carrier (SCC) Band	PCC BW (MHz)	SCC BW (MHz)	PCC Channel	SCC Channel	PCC UL RB Allocation	PCC DL RB Allocation	SCC DL RB Allocation
CA_26A-41A	26	41	5	20	8715	39750	25 RB with RBstart=0	25 RB with RBstart=0	100 RB with RBstart=0
					8865	40620	25 RB with RBstart=0	25 RB with RBstart=0	100 RB with RBstart=0
					9015	41490	25 RB with RBstart=0	25 RB with RBstart=0	100 RB with RBstart=0
CA_30A-2A	30	2	10	10	9820	650	25 RB with RBstart=25	50 RB with RBstart=0	50 RB with RBstart=0
					9820	900	25 RB with RBstart=25	50 RB with RBstart=0	50 RB with RBstart=0
					9820	1150	25 RB with RBstart=25	50 RB with RBstart=0	50 RB with RBstart=0
CA_30A-4A ⁵	30	4	10	10	9820	2000	25 RB with RBstart=25	50 RB with RBstart=0	50 RB with RBstart=0
					9820	2175	25 RB with RBstart=25	50 RB with RBstart=0	50 RB with RBstart=0
					9820	2350	25 RB with RBstart=25	50 RB with RBstart=0	50 RB with RBstart=0
CA_30A-5A	30	5	10	10	9820	2450	25 RB with RBstart=25	50 RB with RBstart=0	50 RB with RBstart=0
					9820	2525	25 RB with RBstart=25	50 RB with RBstart=0	50 RB with RBstart=0
					9820	2600	25 RB with RBstart=25	50 RB with RBstart=0	50 RB with RBstart=0
CA_30A-12A	30	12	10	5	9820	5035	25 RB with RBstart=25	50 RB with RBstart=0	25 RB with RBstart=0
					9820	5095	25 RB with RBstart=25	50 RB with RBstart=0	25 RB with RBstart=0
					9820	5155	25 RB with RBstart=25	50 RB with RBstart=0	25 RB with RBstart=0
CA_30A-29A	30	29	10	10	9820	9720	25 RB with RBstart=25	50 RB with RBstart=0	50 RB with RBstart=0
CA_30A-66A ⁵	30	66	10	10	9820	66486	25 RB with RBstart=25	50 RB with RBstart=0	50 RB with RBstart=0
					9820	66786	25 RB with RBstart=25	50 RB with RBstart=0	50 RB with RBstart=0
					9820	67086 ⁷	25 RB with RBstart=25	50 RB with RBstart=0	50 RB with RBstart=0
					9820	67286	25 RB with RBstart=25	50 RB with RBstart=0	50 RB with RBstart=0

TABLE 6-25 LTE CARRIER AGGREGATION MODE (2 DOWNLINK CARRIERS, 1 UPLINK CARRIER) TIS
MEASUREMENTS TABLE FOR THE PRIMARY MECHANICAL MODE¹

Carrier Aggregation Combination	Primary Component Carrier (PCC) Band	Secondary Component Carrier (SCC) Band	PCC BW (MHz)	SCC BW (MHz)	PCC Channel	SCC Channel	PCC UL RB Allocation	PCC DL RB Allocation	SCC DL RB Allocation
CA_41A-25A	41	25	20	5	39750	8065	100 RB with RBstart=0	100 RB with RBstart=0	25 RB with RBstart=0
					40620	8365	100 RB with RBstart=0	100 RB with RBstart=0	25 RB with RBstart=0
					41490	8665	100 RB with RBstart=0	100 RB with RBstart=0	25 RB with RBstart=0
CA_41A-26A	41	26	20	5	39750	8715	100 RB with RBstart=0	100 RB with RBstart=0	25 RB with RBstart=0
					40620	8865	100 RB with RBstart=0	100 RB with RBstart=0	25 RB with RBstart=0
					41490	9015	100 RB with RBstart=0	100 RB with RBstart=0	25 RB with RBstart=0
CA_41A-41A	41	41	20	20	39750	40620	100 RB with RBstart=0	100 RB with RBstart=0	100 RB with RBstart=0
					40620	41490	100 RB with RBstart=0	100 RB with RBstart=0	100 RB with RBstart=0
					41490	39750	100 RB with RBstart=0	100 RB with RBstart=0	100 RB with RBstart=0
CA_41C	41	41	20	20	39750	39948 ¹¹	100 RB with RBstart=0	100 RB with RBstart=0	100 RB with RBstart=0
					40620	40422 ¹²	100 RB with RBstart=0	100 RB with RBstart=0	100 RB with RBstart=0
					40620	40818 ¹³	100 RB with RBstart=0	100 RB with RBstart=0	100 RB with RBstart=0
					41490	41292 ¹²	100 RB with RBstart=0	100 RB with RBstart=0	100 RB with RBstart=0
CA_48A-2A	48	2	10	10	55290	650	50 RB with RBstart=0	50 RB with RBstart=0	50 RB with RBstart=0
					55990	900	50 RB with RBstart=0	50 RB with RBstart=0	50 RB with RBstart=0
					56690	1150	50 RB with RBstart=0	50 RB with RBstart=0	50 RB with RBstart=0
CA_48A-5A	48	5	10	10	55290	2450	50 RB with RBstart=0	50 RB with RBstart=0	50 RB with RBstart=0
					55990	2525	50 RB with RBstart=0	50 RB with RBstart=0	50 RB with RBstart=0
					56690	2600	50 RB with RBstart=0	50 RB with RBstart=0	50 RB with RBstart=0
CA_48A-13A	48	13	10	10	55290	5230	50 RB with RBstart=0	50 RB with RBstart=0	50 RB with RBstart=0
					55990	5230	50 RB with RBstart=0	50 RB with RBstart=0	50 RB with RBstart=0
					56690	5230	50 RB with RBstart=0	50 RB with RBstart=0	50 RB with RBstart=0

TABLE 6-25 LTE CARRIER AGGREGATION MODE (2 DOWNLINK CARRIERS, 1 UPLINK CARRIER) TIS
MEASUREMENTS TABLE FOR THE PRIMARY MECHANICAL MODE¹

Carrier Aggregation Combination	Primary Component Carrier (PCC) Band	Secondary Component Carrier (SCC) Band	PCC BW (MHz)	SCC BW (MHz)	PCC Channel	SCC Channel	PCC UL RB Allocation	PCC DL RB Allocation	SCC DL RB Allocation
CA_48A-66A	48	66	10	10	55290	66486	50 RB with RBstart=0	50 RB with RBstart=0	50 RB with RBstart=0
					55990	66786	50 RB with RBstart=0	50 RB with RBstart=0	50 RB with RBstart=0
					55990	67086 ⁷	50 RB with RBstart=0	50 RB with RBstart=0	50 RB with RBstart=0
					56690	67286	50 RB with RBstart=0	50 RB with RBstart=0	50 RB with RBstart=0
CA_66A-2A ⁵	66	2	10	10	66486	650	50 RB with RBstart=0	50 RB with RBstart=0	50 RB with RBstart=0
					66786	900	50 RB with RBstart=0	50 RB with RBstart=0	50 RB with RBstart=0
					67086	1150	50 RB with RBstart=0	50 RB with RBstart=0	50 RB with RBstart=0
CA_66A-5A ⁵	66	5	10	10	66486	2450	50 RB with RBstart=0	50 RB with RBstart=0	50 RB with RBstart=0
					66786	2525	50 RB with RBstart=0	50 RB with RBstart=0	50 RB with RBstart=0
					67086	2600	50 RB with RBstart=0	50 RB with RBstart=0	50 RB with RBstart=0
CA_66A-12A ^{5,6}	66	12	10	5	66486	5035	50 RB with RBstart=0	50 RB with RBstart=0	25 RB with RBstart=0
					66786	5095	50 RB with RBstart=0	50 RB with RBstart=0	25 RB with RBstart=0
					67086	5155	50 RB with RBstart=0	50 RB with RBstart=0	25 RB with RBstart=0
CA_66A-13A ⁵	66	13	10	10	66486	5230	50 RB with RBstart=0	50 RB with RBstart=0	50 RB with RBstart=0
					66786	5230	50 RB with RBstart=0	50 RB with RBstart=0	50 RB with RBstart=0
					67086	5230	50 RB with RBstart=0	50 RB with RBstart=0	50 RB with RBstart=0
CA_66A-17A ^{5,6}	66	17	10	10	66486	5800	50 RB with RBstart=0	50 RB with RBstart=0	50 RB with RBstart=0
					66786	5800	50 RB with RBstart=0	50 RB with RBstart=0	50 RB with RBstart=0
					67086	5800	50 RB with RBstart=0	50 RB with RBstart=0	50 RB with RBstart=0
CA_66A-29A ⁵	66	29	10	10	66486	9720	50 RB with RBstart=0	50 RB with RBstart=0	50 RB with RBstart=0
					66786	9720	50 RB with RBstart=0	50 RB with RBstart=0	50 RB with RBstart=0
					67086	9720	50 RB with RBstart=0	50 RB with RBstart=0	50 RB with RBstart=0

TABLE 6-25 LTE CARRIER AGGREGATION MODE (2 DOWNLINK CARRIERS, 1 UPLINK CARRIER) TIS MEASUREMENTS TABLE FOR THE PRIMARY MECHANICAL MODE¹

Carrier Aggregation Combination	Primary Component Carrier (PCC) Band	Secondary Component Carrier (SCC) Band	PCC BW (MHz)	SCC BW (MHz)	PCC Channel	SCC Channel	PCC UL RB Allocation	PCC DL RB Allocation	SCC DL RB Allocation
CA_66A-30A ⁵	66	30	10	10	66486	9820	50 RB with RBstart=0	50 RB with RBstart=0	50 RB with RBstart=0
					66786	9820	50 RB with RBstart=0	50 RB with RBstart=0	50 RB with RBstart=0
					67086	9820	50 RB with RBstart=0	50 RB with RBstart=0	50 RB with RBstart=0
CA_66A-48A ²	66	48	10	10	66486	55290	50 RB with RBstart=0	50 RB with RBstart=0	50 RB with RBstart=0
					66786	55990	50 RB with RBstart=0	50 RB with RBstart=0	50 RB with RBstart=0
					67086	55290 ¹⁴	50 RB with RBstart=0	50 RB with RBstart=0	50 RB with RBstart=0
					67086	56690	50 RB with RBstart=0	50 RB with RBstart=0	50 RB with RBstart=0
CA_66C ^{9,15}	66	66	20	20	66536	66734 ¹¹	100 RB with RBstart=0	100 RB with RBstart=0	100 RB with RBstart=0
					66786	66984 ¹³	100 RB with RBstart=0	100 RB with RBstart=0	100 RB with RBstart=0
					67036	67234	100 RB with RBstart=0	100 RB with RBstart=0	100 RB with RBstart=0
CA_66A-66A ⁵	66	66	10	10	66486	67286	50 RB with RBstart=0	50 RB with RBstart=0	50 RB with RBstart=0
					66486	67086 ⁷	50 RB with RBstart=0	50 RB with RBstart=0	50 RB with RBstart=0
					66786	66486	50 RB with RBstart=0	50 RB with RBstart=0	50 RB with RBstart=0
					67086	66786	50 RB with RBstart=0	50 RB with RBstart=0	50 RB with RBstart=0

TABLE 6-25 LTE CARRIER AGGREGATION MODE (2 DOWNLINK CARRIERS, 1 UPLINK CARRIER) TIS MEASUREMENTS TABLE FOR THE PRIMARY MECHANICAL MODE¹

Carrier Aggregation Combination	Primary Component Carrier (PCC) Band	Secondary Component Carrier (SCC) Band	PCC BW (MHz)	SCC BW (MHz)	PCC Channel	SCC Channel	PCC UL RB Allocation	PCC DL RB Allocation	SCC DL RB Allocation
CA_70C	70	70	15	10	68411	68531	75 RB with RBstart=0	75 RB with RBstart=0	50 RB with RBstart=0

Note 1: Primary Mechanical Mode refers to device configured in preferred mode per manufacturer instructions (typically means antenna extended, fold or portrait slide open, but depends on form factor).

Note 2: This combination creates harmonic, intermodulation, or self-desense interference to the SCC. When measuring the PCC, the power level of the SCC shall be adjusted as needed to maintain the LTE carrier aggregation connection and error free operation on the SCC.

Note 3: An additional set of channel conditions was added for CA_2A-2A to address the case where Wgap is ≤ 10 (per Table 7.3.1A-3 of 3GPP TS 36.101).

Note 4: TIS testing is not required for the PCC on channel 800. TIS testing is only required for the SCC on channel 650.

Note 5: If the device supports both CA_4A-xA and CA_66A-xA (where x is the band number of the SCC), then testing is only required in CA_66A-xA. Similarly, if the device supports both CA_xA-4A and CA_xA-66A (where x is the band number of the PCC), then testing is only required in CA_xA-66A.

Note 6: If the device supports both CA_12A-xA and CA_17A-xA (where x is the band number of the SCC), then testing is only required in CA_12A-xA. Similarly, if the device supports both CA_xA-12A and CA_xA-17A (where x is the band number of the PCC), then testing is only required in CA_xA-12A.

Note 7: When there is a Band 66 SCC on channel 67086, TIS testing is not required on the PCC. TIS testing is only required on the Band 66 SCC on channel 67086.

Note 8: An additional set of channel conditions was added for CA_5A-5A to address the case where receiver sensitivity relaxation is allowed per Table 7.3.1A-3 of 3GPP TS 36.101.

Note 9: Single point offset testing using the pattern data from standalone mode is not allowed when the channel bandwidth in CA mode is different from the channel bandwidth in standalone mode.

Note 10: TIS testing is not required for the PCC on channel 2425 when the SCC is on channel 2625. TIS testing is only required for the SCC on channel 2625.

Note 11: TIS testing on the SCC is not required when the antenna configuration remains the same when the PCC changes to the mid channel.

Note 12: TIS testing on the SCC is not required when the antenna configuration remains the same when the PCC changes to the low channel.

Note 13: TIS testing on the SCC is not required when the antenna configuration remains the same when the PCC changes to the high channel.

Note 14: TIS testing is not required on the Band 66 PCC on channel 67086. TIS testing is only required on the Band 48 SCC on channel 55290.

Note 15: Since all Band 66-capable devices are required to support both CA_66B and CA_66C per 3GPP TS 36.101, testing of CA_66B is not required.

Hand phantom only and/or free-space testing shall be conducted based on device type, as specified in [Appendix O](#). Refer to [Appendix C](#) for hand testing requirements. Perform each test on all supported CA modes defined in [Table 6-25](#) according to the use cases associated with each band as specified in with the EUT antenna extended and retracted, as applicable.

Note: Head-adjacent testing is not required for LTE CA.

Note: EUTs incapable of supporting the aggregated channel BW associated the CA modes specified in [Table 6-25](#) do not need to be tested.

6.16.2 Criteria

Results shall be reported as specified in [Appendix B](#) using the figures of merit given in [Appendix B.3](#). [Appendix B.1](#) contains the pass/fail OTA tables for 2 downlink LTE carrier aggregation. Reports shall include results for free-space and hand only configurations (if applicable) across all applicable channels defined in [Table 6-25](#). When applicable, the receiver performance in all CA band combinations shall be measured once with the EUT antenna extended and again with it retracted.

C-TIS shall meet the limits for the PCC and the SCC as shown in [Table 6-26](#).

TABLE 6-26 LTE MAXIMUM C-TIS LEVEL REQUIREMENTS FOR PCC AND SCC IN CARRIER AGGREGATION MODE (2 DOWNLINK CARRIERS, 1 UPLINK CARRIER) FOR THE PRIMARY MECHANICAL MODE¹

Carrier Aggregation Combination	PCC / SCC	Device Held Up to Head for Voice (Yes/No)	Device Width (mm) ²	Free Space	HL and HR
CA_2A-2A ³	PCC	Yes ⁴	≤72	TBD	TBD
			>72	TBD	TBD
		No ⁵	All	TBD	N/A
	SCC	Yes ⁴	≤72	TBD	TBD
			>72	TBD	TBD
		No ⁵	All	TBD	N/A
CA_2A-4A	PCC	Yes ⁴	≤72	TBD	TBD
			>72	TBD	TBD
		No ⁵	All	TBD	N/A
	SCC	Yes ⁴	≤72	TBD	TBD
			>72	TBD	TBD
		No ⁵	All	TBD	N/A
CA_2A-5A	PCC	Yes ⁴	≤72	TBD	TBD
			>72	TBD	TBD
		No ⁵	All	TBD	N/A
	SCC	Yes ⁴	≤72	TBD	TBD
			>72	TBD	TBD
		No ⁵	All	TBD	N/A
CA_2A-12A	PCC	Yes ⁴	≤72	TBD	TBD
			>72	TBD	TBD
		No ⁵	All	TBD	N/A
	SCC	Yes ⁴	≤72	TBD	TBD
			>72	TBD	TBD
		No ⁵	All	TBD	N/A
CA_2A-13A	PCC	Yes ⁴	≤72	TBD	TBD
			>72	TBD	TBD
		No ⁵	All	TBD	N/A
	SCC	Yes ⁴	≤72	TBD	TBD
			>72	TBD	TBD
		No ⁵	All	TBD	N/A

TABLE 6-26 LTE MAXIMUM C-TIS LEVEL REQUIREMENTS FOR PCC AND SCC IN CARRIER AGGREGATION MODE (2 DOWNLINK CARRIERS, 1 UPLINK CARRIER) FOR THE PRIMARY MECHANICAL MODE¹

Carrier Aggregation Combination	PCC / SCC	Device Held Up to Head for Voice (Yes/No)	Device Width (mm) ²	Free Space	HL and HR
CA_2A-17A	PCC	Yes ⁴	≤72	TBD	TBD
			>72	TBD	TBD
		No ⁵	All	TBD	N/A
	SCC	Yes ⁴	≤72	TBD	TBD
			>72	TBD	TBD
		No ⁵	All	TBD	N/A
CA_2A-29A	PCC	Yes ⁴	≤72	TBD	TBD
			>72	TBD	TBD
		No ⁵	All	TBD	N/A
	SCC	Yes ⁴	≤72	TBD	TBD
			>72	TBD	TBD
		No ⁵	All	TBD	N/A
CA_2A-30A	PCC	Yes ⁴	≤72	TBD	TBD
			>72	TBD	TBD
		No ⁵	All	TBD	N/A
	SCC	Yes ⁴	≤72	TBD	TBD
			>72	TBD	TBD
		No ⁵	All	TBD	N/A
CA_2A-48A	PCC	Yes ⁴	≤72	TBD	TBD
			>72	TBD	TBD
		No ⁵	All	TBD	N/A
	SCC	Yes ⁴	≤72	TBD	TBD
			>72	TBD	TBD
		No ⁵	All	TBD	N/A
CA_2A-66A	PCC	Yes ⁴	≤72	TBD	TBD
			>72	TBD	TBD
		No ⁵	All	TBD	N/A
	SCC	Yes ⁴	≤72	TBD	TBD
			>72	TBD	TBD
		No ⁵	All	TBD	N/A

TABLE 6-26 LTE MAXIMUM C-TIS LEVEL REQUIREMENTS FOR PCC AND SCC IN CARRIER AGGREGATION MODE (2 DOWNLINK CARRIERS, 1 UPLINK CARRIER) FOR THE PRIMARY MECHANICAL MODE¹

Carrier Aggregation Combination	PCC / SCC	Device Held Up to Head for Voice (Yes/No)	Device Width (mm) ²	Free Space	HL and HR
CA_4A-2A	PCC	Yes ⁴	≤72	TBD	TBD
			>72	TBD	TBD
		No ⁵	All	TBD	N/A
	SCC	Yes ⁴	≤72	TBD	TBD
			>72	TBD	TBD
		No ⁵	All	TBD	N/A
CA_4A-4A	PCC	Yes ⁴	≤72	TBD	TBD
			>72	TBD	TBD
		No ⁵	All	TBD	N/A
	SCC	Yes ⁴	≤72	TBD	TBD
			>72	TBD	TBD
		No ⁵	All	TBD	N/A
CA_4A-5A	PCC	Yes ⁴	≤72	TBD	TBD
			>72	TBD	TBD
		No ⁵	All	TBD	N/A
	SCC	Yes ⁴	≤72	TBD	TBD
			>72	TBD	TBD
		No ⁵	All	TBD	N/A
CA_4A-12A	PCC	Yes ⁴	≤72	TBD	TBD
			>72	TBD	TBD
		No ⁵	All	TBD	N/A
	SCC	Yes ⁴	≤72	TBD	TBD
			>72	TBD	TBD
		No ⁵	All	TBD	N/A
CA_4A-13A	PCC	Yes ⁴	≤72	TBD	TBD
			>72	TBD	TBD
		No ⁵	All	TBD	N/A
	SCC	Yes ⁴	≤72	TBD	TBD
			>72	TBD	TBD
		No ⁵	All	TBD	N/A

TABLE 6-26 LTE MAXIMUM C-TIS LEVEL REQUIREMENTS FOR PCC AND SCC IN CARRIER AGGREGATION MODE (2 DOWNLINK CARRIERS, 1 UPLINK CARRIER) FOR THE PRIMARY MECHANICAL MODE¹

Carrier Aggregation Combination	PCC / SCC	Device Held Up to Head for Voice (Yes/No)	Device Width (mm) ²	Free Space	HL and HR
CA_4A-17A	PCC	Yes ⁴	≤72	TBD	TBD
			>72	TBD	TBD
		No ⁵	All	TBD	N/A
	SCC	Yes ⁴	≤72	TBD	TBD
			>72	TBD	TBD
		No ⁵	All	TBD	N/A
CA_4A-29A	PCC	Yes ⁴	≤72	TBD	TBD
			>72	TBD	TBD
		No ⁵	All	TBD	N/A
	SCC	Yes ⁴	≤72	TBD	TBD
			>72	TBD	TBD
		No ⁵	All	TBD	N/A
CA_4A-30A	PCC	Yes ⁴	≤72	TBD	TBD
			>72	TBD	TBD
		No ⁵	All	TBD	N/A
	SCC	Yes ⁴	≤72	TBD	TBD
			>72	TBD	TBD
		No ⁵	All	TBD	N/A
CA_5A-2A	PCC	Yes ⁴	≤72	TBD	TBD
			>72	TBD	TBD
		No ⁵	All	TBD	N/A
	SCC	Yes ⁴	≤72	TBD	TBD
			>72	TBD	TBD
		No ⁵	All	TBD	N/A
CA_5A-4A	PCC	Yes ⁴	≤72	TBD	TBD
			>72	TBD	TBD
		No ⁵	All	TBD	N/A
	SCC	Yes ⁴	≤72	TBD	TBD
			>72	TBD	TBD
		No ⁵	All	TBD	N/A

TABLE 6-26 LTE MAXIMUM C-TIS LEVEL REQUIREMENTS FOR PCC AND SCC IN CARRIER AGGREGATION MODE (2 DOWNLINK CARRIERS, 1 UPLINK CARRIER) FOR THE PRIMARY MECHANICAL MODE¹

Carrier Aggregation Combination	PCC / SCC	Device Held Up to Head for Voice (Yes/No)	Device Width (mm) ²	Free Space	HL and HR
CA_5B	PCC	Yes ⁴	≤72	TBD	TBD
			>72	TBD	TBD
		No ⁵	All	TBD	N/A
	SCC	Yes ⁴	≤72	TBD	TBD
			>72	TBD	TBD
		No ⁵	All	TBD	N/A
CA_5A-5A	PCC	Yes ⁴	≤72	TBD	TBD
			>72	TBD	TBD
		No ⁵	All	TBD	N/A
	SCC	Yes ⁴	≤72	TBD	TBD
			>72	TBD	TBD
		No ⁵	All	TBD	N/A
CA_5A-30A	PCC	Yes ⁴	≤72	TBD	TBD
			>72	TBD	TBD
		No ⁵	All	TBD	N/A
	SCC	Yes ⁴	≤72	TBD	TBD
			>72	TBD	TBD
		No ⁵	All	TBD	N/A
CA_5A-48A	PCC	Yes ⁴	≤72	TBD	TBD
			>72	TBD	TBD
		No ⁵	All	TBD	N/A
	SCC	Yes ⁴	≤72	TBD	TBD
			>72	TBD	TBD
		No ⁵	All	TBD	N/A
CA_5A-66A	PCC	Yes ⁴	≤72	TBD	TBD
			>72	TBD	TBD
		No ⁵	All	TBD	N/A
	SCC	Yes ⁴	≤72	TBD	TBD
			>72	TBD	TBD
		No ⁵	All	TBD	N/A

TABLE 6-26 LTE MAXIMUM C-TIS LEVEL REQUIREMENTS FOR PCC AND SCC IN CARRIER AGGREGATION MODE (2 DOWNLINK CARRIERS, 1 UPLINK CARRIER) FOR THE PRIMARY MECHANICAL MODE¹

Carrier Aggregation Combination	PCC / SCC	Device Held Up to Head for Voice (Yes/No)	Device Width (mm) ²	Free Space	HL and HR
CA_12A-2A	PCC	Yes ⁴	≤72	TBD	TBD
			>72	TBD	TBD
		No ⁵	All	TBD	N/A
	SCC	Yes ⁴	≤72	TBD	TBD
			>72	TBD	TBD
		No ⁵	All	TBD	N/A
CA_12A-4A ³	PCC	Yes ⁴	≤72	TBD	TBD
			>72	TBD	TBD
		No ⁵	All	TBD	N/A
	SCC	Yes ⁴	≤72	TBD	TBD
			>72	TBD	TBD
		No ⁵	All	TBD	N/A
CA_12A-30A	PCC	Yes ⁴	≤72	TBD	TBD
			>72	TBD	TBD
		No ⁵	All	TBD	N/A
	SCC	Yes ⁴	≤72	TBD	TBD
			>72	TBD	TBD
		No ⁵	All	TBD	N/A
CA_12A-66A	PCC	Yes ⁴	≤72	TBD	TBD
			>72	TBD	TBD
		No ⁵	All	TBD	N/A
	SCC	Yes ⁴	≤72	TBD	TBD
			>72	TBD	TBD
		No ⁵	All	TBD	N/A
CA_13A-2A	PCC	Yes ⁴	≤72	TBD	TBD
			>72	TBD	TBD
		No ⁵	All	TBD	N/A
	SCC	Yes ⁴	≤72	TBD	TBD
			>72	TBD	TBD
		No ⁵	All	TBD	N/A

TABLE 6-26 LTE MAXIMUM C-TIS LEVEL REQUIREMENTS FOR PCC AND SCC IN CARRIER AGGREGATION MODE (2 DOWNLINK CARRIERS, 1 UPLINK CARRIER) FOR THE PRIMARY MECHANICAL MODE¹

Carrier Aggregation Combination	PCC / SCC	Device Held Up to Head for Voice (Yes/No)	Device Width (mm) ²	Free Space	HL and HR
CA_13A-4A	PCC	Yes ⁴	≤72	TBD	TBD
			>72	TBD	TBD
		No ⁵	All	TBD	N/A
	SCC	Yes ⁴	≤72	TBD	TBD
			>72	TBD	TBD
		No ⁵	All	TBD	N/A
CA_13A-48A	PCC	Yes ⁴	≤72	TBD	TBD
			>72	TBD	TBD
		No ⁵	All	TBD	N/A
	SCC	Yes ⁴	≤72	TBD	TBD
			>72	TBD	TBD
		No ⁵	All	TBD	N/A
CA_13A-66A	PCC	Yes ⁴	≤72	TBD	TBD
			>72	TBD	TBD
		No ⁵	All	TBD	N/A
	SCC	Yes ⁴	≤72	TBD	TBD
			>72	TBD	TBD
		No ⁵	All	TBD	N/A
CA_17A-2A	PCC	Yes ⁴	≤72	TBD	TBD
			>72	TBD	TBD
		No ⁵	All	TBD	N/A
	SCC	Yes ⁴	≤72	TBD	TBD
			>72	TBD	TBD
		No ⁵	All	TBD	N/A
CA_17A-4A3	PCC	Yes ⁴	≤72	TBD	TBD
			>72	TBD	TBD
		No ⁵	All	TBD	N/A
	SCC	Yes ⁴	≤72	TBD	TBD
			>72	TBD	TBD
		No ⁵	All	TBD	N/A

TABLE 6-26 LTE MAXIMUM C-TIS LEVEL REQUIREMENTS FOR PCC AND SCC IN CARRIER AGGREGATION MODE (2 DOWNLINK CARRIERS, 1 UPLINK CARRIER) FOR THE PRIMARY MECHANICAL MODE¹

Carrier Aggregation Combination	PCC / SCC	Device Held Up to Head for Voice (Yes/No)	Device Width (mm) ²	Free Space	HL and HR
CA_17A-66A	PCC	Yes ⁴	≤72	TBD	TBD
			>72	TBD	TBD
		No ⁵	All	TBD	N/A
	SCC	Yes ⁴	≤72	TBD	TBD
			>72	TBD	TBD
		No ⁵	All	TBD	N/A
CA_25A-25A	PCC	Yes ⁴	≤72	TBD	TBD
			>72	TBD	TBD
		No ⁵	All	TBD	N/A
	SCC	Yes ⁴	≤72	TBD	TBD
			>72	TBD	TBD
		No ⁵	All	TBD	N/A
CA_25A-26A	PCC	Yes ⁴	≤72	TBD	TBD
			>72	TBD	TBD
		No ⁵	All	TBD	N/A
	SCC	Yes ⁴	≤72	TBD	TBD
			>72	TBD	TBD
		No ⁵	All	TBD	N/A
CA_25A-41A	PCC	Yes ⁴	≤72	TBD	TBD
			>72	TBD	TBD
		No ⁵	All	TBD	N/A
	SCC	Yes ⁴	≤72	TBD	TBD
			>72	TBD	TBD
		No ⁵	All	TBD	N/A
CA_26A-25A	PCC	Yes ⁴	≤72	TBD	TBD
			>72	TBD	TBD
		No ⁵	All	TBD	N/A
	SCC	Yes ⁴	≤72	TBD	TBD
			>72	TBD	TBD
		No ⁵	All	TBD	N/A

TABLE 6-26 LTE MAXIMUM C-TIS LEVEL REQUIREMENTS FOR PCC AND SCC IN CARRIER AGGREGATION MODE (2 DOWNLINK CARRIERS, 1 UPLINK CARRIER) FOR THE PRIMARY MECHANICAL MODE¹

Carrier Aggregation Combination	PCC / SCC	Device Held Up to Head for Voice (Yes/No)	Device Width (mm) ²	Free Space	HL and HR
CA_26A-41A	PCC	Yes ⁴	≤72	TBD	TBD
			>72	TBD	TBD
		No ⁵	All	TBD	N/A
	SCC	Yes ⁴	≤72	TBD	TBD
			>72	TBD	TBD
		No ⁵	All	TBD	N/A
CA_30A-2A	PCC	Yes ⁴	≤72	TBD	TBD
			>72	TBD	TBD
		No ⁵	All	TBD	N/A
	SCC	Yes ⁴	≤72	TBD	TBD
			>72	TBD	TBD
		No ⁵	All	TBD	N/A
CA_30A-4A	PCC	Yes ⁴	≤72	TBD	TBD
			>72	TBD	TBD
		No ⁵	All	TBD	N/A
	SCC	Yes ⁴	≤72	TBD	TBD
			>72	TBD	TBD
		No ⁵	All	TBD	N/A
CA_30A-5A	PCC	Yes ⁴	≤72	TBD	TBD
			>72	TBD	TBD
		No ⁵	All	TBD	N/A
	SCC	Yes ⁴	≤72	TBD	TBD
			>72	TBD	TBD
		No ⁵	All	TBD	N/A
CA_30A-12A	PCC	Yes ⁴	≤72	TBD	TBD
			>72	TBD	TBD
		No ⁵	All	TBD	N/A
	SCC	Yes ⁴	≤72	TBD	TBD
			>72	TBD	TBD
		No ⁵	All	TBD	N/A

TABLE 6-26 LTE MAXIMUM C-TIS LEVEL REQUIREMENTS FOR PCC AND SCC IN CARRIER AGGREGATION MODE (2 DOWNLINK CARRIERS, 1 UPLINK CARRIER) FOR THE PRIMARY MECHANICAL MODE¹

Carrier Aggregation Combination	PCC / SCC	Device Held Up to Head for Voice (Yes/No)	Device Width (mm) ²	Free Space	HL and HR
CA_30A-29A	PCC	Yes ⁴	≤72	TBD	TBD
			>72	TBD	TBD
		No ⁵	All	TBD	N/A
	SCC	Yes ⁴	≤72	TBD	TBD
			>72	TBD	TBD
		No ⁵	All	TBD	N/A
CA_30A-66A	PCC	Yes ⁴	≤72	TBD	TBD
			>72	TBD	TBD
		No ⁵	All	TBD	N/A
	SCC	Yes ⁴	≤72	TBD	TBD
			>72	TBD	TBD
		No ⁵	All	TBD	N/A
CA_41A-25A	PCC	Yes ⁴	≤72	TBD	TBD
			>72	TBD	TBD
		No ⁵	All	TBD	N/A
	SCC	Yes ⁴	≤72	TBD	TBD
			>72	TBD	TBD
		No ⁵	All	TBD	N/A
CA_41A-26A	PCC	Yes ⁴	≤72	TBD	TBD
			>72	TBD	TBD
		No ⁵	All	TBD	N/A
	SCC	Yes ⁴	≤72	TBD	TBD
			>72	TBD	TBD
		No ⁵	All	TBD	N/A
CA_41C	PCC	Yes ⁴	≤72	TBD	TBD
			>72	TBD	TBD
		No ⁵	All	TBD	N/A
	SCC	Yes ⁴	≤72	TBD	TBD
			>72	TBD	TBD
		No ⁵	All	TBD	N/A

TABLE 6-26 LTE MAXIMUM C-TIS LEVEL REQUIREMENTS FOR PCC AND SCC IN CARRIER AGGREGATION MODE (2 DOWNLINK CARRIERS, 1 UPLINK CARRIER) FOR THE PRIMARY MECHANICAL MODE¹

Carrier Aggregation Combination	PCC / SCC	Device Held Up to Head for Voice (Yes/No)	Device Width (mm) ²	Free Space	HL and HR
CA_41A-41A	PCC	Yes ⁴	≤72	TBD	TBD
			>72	TBD	TBD
		No ⁵	All	TBD	N/A
	SCC	Yes ⁴	≤72	TBD	TBD
			>72	TBD	TBD
		No ⁵	All	TBD	N/A
CA_48A-2A	PCC	Yes ⁴	≤72	TBD	TBD
			>72	TBD	TBD
		No ⁵	All	TBD	N/A
	SCC	Yes ⁴	≤72	TBD	TBD
			>72	TBD	TBD
		No ⁵	All	TBD	N/A
CA_48A-5A	PCC	Yes ⁴	≤72	TBD	TBD
			>72	TBD	TBD
		No ⁵	All	TBD	N/A
	SCC	Yes ⁴	≤72	TBD	TBD
			>72	TBD	TBD
		No ⁵	All	TBD	N/A
CA_48A-13A	PCC	Yes ⁴	≤72	TBD	TBD
			>72	TBD	TBD
		No ⁵	All	TBD	N/A
	SCC	Yes ⁴	≤72	TBD	TBD
			>72	TBD	TBD
		No ⁵	All	TBD	N/A
CA_48A-66A	PCC	Yes ⁴	≤72	TBD	TBD
			>72	TBD	TBD
		No ⁵	All	TBD	N/A
	SCC	Yes ⁴	≤72	TBD	TBD
			>72	TBD	TBD
		No ⁵	All	TBD	N/A

TABLE 6-26 LTE MAXIMUM C-TIS LEVEL REQUIREMENTS FOR PCC AND SCC IN CARRIER AGGREGATION MODE (2 DOWNLINK CARRIERS, 1 UPLINK CARRIER) FOR THE PRIMARY MECHANICAL MODE¹

Carrier Aggregation Combination	PCC / SCC	Device Held Up to Head for Voice (Yes/No)	Device Width (mm) ²	Free Space	HL and HR
CA_66A-2A	PCC	Yes ⁴	≤72	TBD	TBD
			>72	TBD	TBD
		No ⁵	All	TBD	N/A
	SCC	Yes ⁴	≤72	TBD	TBD
			>72	TBD	TBD
		No ⁵	All	TBD	N/A
CA_66A-5A	PCC	Yes ⁴	≤72	TBD	TBD
			>72	TBD	TBD
		No ⁵	All	TBD	N/A
	SCC	Yes ⁴	≤72	TBD	TBD
			>72	TBD	TBD
		No ⁵	All	TBD	N/A
CA_66A-12A	PCC	Yes ⁴	≤72	TBD	TBD
			>72	TBD	TBD
		No ⁵	All	TBD	N/A
	SCC	Yes ⁴	≤72	TBD	TBD
			>72	TBD	TBD
		No ⁵	All	TBD	N/A
CA_66A-13A	PCC	Yes ⁴	≤72	TBD	TBD
			>72	TBD	TBD
		No ⁵	All	TBD	N/A
	SCC	Yes ⁴	≤72	TBD	TBD
			>72	TBD	TBD
		No ⁵	All	TBD	N/A
CA_66A-17A	PCC	Yes ⁴	≤72	TBD	TBD
			>72	TBD	TBD
		No ⁵	All	TBD	N/A
	SCC	Yes ⁴	≤72	TBD	TBD
			>72	TBD	TBD
		No ⁵	All	TBD	N/A

TABLE 6-26 LTE MAXIMUM C-TIS LEVEL REQUIREMENTS FOR PCC AND SCC IN CARRIER AGGREGATION MODE (2 DOWNLINK CARRIERS, 1 UPLINK CARRIER) FOR THE PRIMARY MECHANICAL MODE¹

Carrier Aggregation Combination	PCC / SCC	Device Held Up to Head for Voice (Yes/No)	Device Width (mm) ²	Free Space	HL and HR
CA_66A-29A	PCC	Yes ⁴	≤72	TBD	TBD
			>72	TBD	TBD
		No ⁵	All	TBD	N/A
	SCC	Yes ⁴	≤72	TBD	TBD
			>72	TBD	TBD
		No ⁵	All	TBD	N/A
CA_66A-30A	PCC	Yes ⁴	≤72	TBD	TBD
			>72	TBD	TBD
		No ⁵	All	TBD	N/A
	SCC	Yes ⁴	≤72	TBD	TBD
			>72	TBD	TBD
		No ⁵	All	TBD	N/A
CA_66A-48A	PCC	Yes ⁴	≤72	TBD	TBD
			>72	TBD	TBD
		No ⁵	All	TBD	N/A
	SCC	Yes ⁴	≤72	TBD	TBD
			>72	TBD	TBD
		No ⁵	All	TBD	N/A
CA_66C	PCC	Yes ⁴	≤72	TBD	TBD
			>72	TBD	TBD
		No ⁵	All	TBD	N/A
	SCC	Yes ⁴	≤72	TBD	TBD
			>72	TBD	TBD
		No ⁵	All	TBD	N/A
CA_66A-66A	PCC	Yes ⁴	≤72	TBD	TBD
			>72	TBD	TBD
		No ⁵	All	TBD	N/A
	SCC	Yes ⁴	≤72	TBD	TBD
			>72	TBD	TBD
		No ⁵	All	TBD	N/A

TABLE 6-26 LTE MAXIMUM C-TIS LEVEL REQUIREMENTS FOR PCC AND SCC IN CARRIER AGGREGATION MODE (2 DOWNLINK CARRIERS, 1 UPLINK CARRIER) FOR THE PRIMARY MECHANICAL MODE¹

Carrier Aggregation Combination	PCC / SCC	Device Held Up to Head for Voice (Yes/No)	Device Width (mm) ²	Free Space	HL and HR
CA_70C	PCC	Yes ⁴	≤72	TBD	TBD
			>72	TBD	TBD
		No ⁵	All	TBD	N/A
	SCC	Yes ⁴	≤72	TBD	TBD
			>72	TBD	TBD
		No ⁵	All	TBD	N/A

Note 1: Primary Mechanical Mode refers to device configured in preferred mode per manufacturer instructions (typically means antenna extended, fold or portrait slide open, but depends on form factor).
 Note 2: Differences between requirements for devices wider and narrower than 72 mm reflect observed differences in OTA performance with different hand phantoms of up to 6 dB.
 Note 3: Different limits for different channel combinations may be needed since the desense effects will be channel dependent.
 Note 4: "Yes" applies if the device supports voice operation in the talking position against the head in LTE mode.
 Note 5: "No" would be applicable to data-centric devices that are not held up against the head, e.g., embedded laptop solutions.

6.17 LTE Three Downlink Carrier Aggregation

The number and type of measurements required to support TIS performance evaluation shall be determined based on the CA specific test requirements for carrier aggregation testing as described in [Appendix O.8.2](#).

6.17.1 Test Procedure

The test procedure for three downlink carrier aggregation with a single uplink carrier is the same as the test procedure for two downlink carrier aggregation with a single uplink carrier (per [Section 6.16.1](#)) with the exception that there are two SCCs.

In order to reduce the need for communication tester upgrades or additions, testing LTE CA 3 DL combinations in stand-alone LTE and/or LTE CA 2 DL is allowed under certain conditions as long as the antenna tuning is set according to the CA 3 DL combination that is being evaluated. The PCC TIS for a 3 DL CA combination may be tested in stand-alone LTE mode with the antenna tuned for operation in the 3 DL CA combination. Each SCC TIS for a 3 DL CA combination may also be tested in stand-alone LTE mode with the antenna tuned for operation in the 3 DL CA combination as long as the SCC is not susceptible to harmonic, intermodulation or self-desense interference from the PCC TX. The SCC TIS for a 3 DL CA combination may be tested in 2 DL CA with the antenna tuned for operation in the 3 DL CA combination, and the 2 DL CA uses the same PCC as the 3 DL CA, when the SCC is susceptible to harmonic, intermodulation or self-desense interference from the PCC TX.

For example, when evaluating an interband 3 DL CA case, CA_xA-yA-zA, where x, y and z are the LTE bands and the PCC is in LTE x, then the following tests are permitted:

1. TIS for x in CA xA-yA-zA may be tested in stand-alone LTE x with the antenna tuned for operation in CA_xA-yA-zA.
2. TIS for y in CA xA-yA-zA may be tested in stand-alone LTE y with the antenna tuned for operation in CA_xA-yA-zA when LTE y is not susceptible harmonic, intermodulation or self-desense interference from LTE x.
3. TIS for y in CA xA-yA-zA may be tested in CA xA-yA with the antenna tuned for operation in CA_xA-yA-zA when LTE y is susceptible harmonic, intermodulation or self-desense interference from LTE x.
4. TIS in z can be evaluated using the same logic as for TIS in y.

Device manufacturers using dynamically tuned antennas should in general have a method of altering the antenna tuning in order to do the necessary antenna tuning optimization during the R&D phase. In general, the settings for the antenna tuner are stored in a tuning file. Consequently, the antenna tuning can be modified by writing a different tuning file into the device. All the stand-alone LTE bands could be tested using the normal tuning file. A second tuning file for testing the 2 DL CA modes could be created where the antenna tuner settings for the stand-alone LTE bands are changed to the antenna tuner settings for the associated 2 DL CA mode. A third tuning file for testing the 3 DL CA modes could be created where the antenna tuner settings for the stand-alone LTE bands are changed to the antenna tuner settings for the associated 3 DL CA mode. In this third tuning file, the antenna tuner settings for the 2 DL CA modes would also be changed to the antenna tuner settings for the associated 3 DL CA mode.

The CA testing will be executed using C-TIS, with all receivers active, following the guidance in the previous portions of [Section 6](#). Refer to [Appendix A](#) for set-up illustrations.

For a given carrier aggregation combination, only a subset of the possible low/mid/high-channel combinations of PCC, SCC1, and SCC2 is tested.

The following LTE bands have channels that can only be tested in DL CA mode: 29

TABLE 6-27 LTE CARRIER AGGREGATION MODE (3 DOWNLINK CARRIERS, 1 UPLINK CARRIER) TIS MEASUREMENTS
TABLE FOR THE PRIMARY MECHANICAL MODE¹

Carrier Aggregation Combination	Primary Component Carrier (PCC) Band	Secondary Component Carriers (SCC1/ SCC2) Bands	PCC BW (MHz)	SCC BWs (MHz)	PCC Channel	SCC Channels	PCC UL RB Allocation	PCC DL RB Allocation	SCC1 DL RB Allocation	SCC2 DL RB Allocation
CA_2A-2A-4A ^{2,3}	2	SCC1=2 SCC2=4	10	SCC1=10 SCC2=10	650	SCC1=900 SCC2=2000	50 RB with RBstart=0	50 RB with RBstart=0	50 RB with RBstart=0	50 RB with RBstart=0
					800 ⁴	SCC1=650 SCC2=2175	32 RB with RBstart=18	50 RB with RBstart=0	50 RB with RBstart=0	50 RB with RBstart=0
					900	SCC1=1150 SCC2=2175	50 RB with RBstart=0	50 RB with RBstart=0	50 RB with RBstart=0	50 RB with RBstart=0
					1150	SCC1=650 SCC2=2350	12 RB with RBstart=38	50 RB with RBstart=0	50 RB with RBstart=0	50 RB with RBstart=0

TABLE 6-27 LTE CARRIER AGGREGATION MODE (3 DOWNLINK CARRIERS, 1 UPLINK CARRIER) TIS MEASUREMENTS
TABLE FOR THE PRIMARY MECHANICAL MODE¹

Carrier Aggregation Combination	Primary Component Carrier (PCC) Band	Secondary Component Carriers (SCC1/ SCC2) Bands	PCC BW (MHz)	SCC BWs (MHz)	PCC Channel	SCC Channels	PCC UL RB Allocation	PCC DL RB Allocation	SCC1 DL RB Allocation	SCC2 DL RB Allocation
CA_2A-2A-5A ^{2,3}	2	SCC1=2 SCC2=5	10	SCC1=10 SCC2=10	650	SCC1=900 SCC2=2450	50 RB with RBstart=0	50 RB with RBstart=0	50 RB with RBstart=0	50 RB with RBstart=0
					800 ⁴	SCC1=650 SCC2=2525	32 RB with RBstart=18	50 RB with RBstart=0	50 RB with RBstart=0	50 RB with RBstart=0
					900	SCC1=1150 SCC2=2525	50 RB with RBstart=0	50 RB with RBstart=0	50 RB with RBstart=0	50 RB with RBstart=0
					1150	SCC1=650 SCC2=2600	12 RB with RBstart=38	50 RB with RBstart=0	50 RB with RBstart=0	50 RB with RBstart=0
CA_2A-2A-12A ^{2,3}	2	SCC1=2 SCC2=12	10	SCC1=10 SCC2=5	650	SCC1=900 SCC2=5035	50 RB with RBstart=0	50 RB with RBstart=0	50 RB with RBstart=0	25 RB with RBstart=0
					800 ⁴	SCC1=650 SCC2=5095	32 RB with RBstart=18	50 RB with RBstart=0	50 RB with RBstart=0	25 RB with RBstart=0
					900	SCC1=1150 SCC2=5095	50 RB with RBstart=0	50 RB with RBstart=0	50 RB with RBstart=0	25 RB with RBstart=0
					1150	SCC1=650 SCC2=5155	12 RB with RBstart=38	50 RB with RBstart=0	50 RB with RBstart=0	25 RB with RBstart=0
CA_2A-2A-13A ^{2,3}	2	SCC1=2 SCC2=13	10	SCC1=10 SCC2=10	650	SCC1=900 SCC2=5230	50 RB with RBstart=0	50 RB with RBstart=0	50 RB with RBstart=0	50 RB with RBstart=0
					800 ⁴	SCC1=650 SCC2=5230	32 RB with RBstart=18	50 RB with RBstart=0	50 RB with RBstart=0	50 RB with RBstart=0
					900	SCC1=1150 SCC2=5230	50 RB with RBstart=0	50 RB with RBstart=0	50 RB with RBstart=0	50 RB with RBstart=0
					1150	SCC1=650 SCC2=5230	12 RB with RBstart=38	50 RB with RBstart=0	50 RB with RBstart=0	50 RB with RBstart=0
CA_2A-2A-66A ^{2,3,5}	2	SCC1=2 SCC2=66	10	SCC1=10 SCC2=10	650	SCC1=900 SCC2=66486	50 RB with RBstart=0	50 RB with RBstart=0	50 RB with RBstart=0	50 RB with RBstart=0
					800 ⁴	SCC1=650 SCC2=66786	32 RB with RBstart=18	50 RB with RBstart=0	50 RB with RBstart=0	50 RB with RBstart=0
					900	SCC1=1150 SCC2=67086	50 RB with RBstart=0	50 RB with RBstart=0	50 RB with RBstart=0	50 RB with RBstart=0
					1150	SCC1=650 SCC2=67286	12 RB with RBstart=38	50 RB with RBstart=0	50 RB with RBstart=0	50 RB with RBstart=0
CA_2A-4A-4A ⁵	2	SCC1=4 SCC2=4	10	SCC1=10 SCC2=10	650	SCC1=2000 SCC2=2175	50 RB with RBstart=0	50 RB with RBstart=0	50 RB with RBstart=0	50 RB with RBstart=0
					900	SCC1=2175 SCC2=2350	50 RB with RBstart=0	50 RB with RBstart=0	50 RB with RBstart=0	50 RB with RBstart=0
					1150	SCC1=2350 SCC2=2000	50 RB with RBstart=0	50 RB with RBstart=0	50 RB with RBstart=0	50 RB with RBstart=0

TABLE 6-27 LTE CARRIER AGGREGATION MODE (3 DOWNLINK CARRIERS, 1 UPLINK CARRIER) TIS MEASUREMENTS
TABLE FOR THE PRIMARY MECHANICAL MODE¹

Carrier Aggregation Combination	Primary Component Carrier (PCC) Band	Secondary Component Carriers (SCC1/SCC2) Bands	PCC BW (MHz)	SCC BWs (MHz)	PCC Channel	SCC Channels	PCC UL RB Allocation	PCC DL RB Allocation	SCC1 DL RB Allocation	SCC2 DL RB Allocation
CA_2A-4A-5A ⁵	2	SCC1=4 SCC2=5	10	SCC1=10 SCC2=10	650	SCC1=2000 SCC2=2450	50 RB with RBstart=0	50 RB with RBstart=0	50 RB with RBstart=0	50 RB with RBstart=0
					900	SCC1=2175 SCC2=2525	50 RB with RBstart=0	50 RB with RBstart=0	50 RB with RBstart=0	50 RB with RBstart=0
					1150	SCC1=2350 SCC2=2600	50 RB with RBstart=0	50 RB with RBstart=0	50 RB with RBstart=0	50 RB with RBstart=0
CA_2A-4A-12A ⁵	2	SCC1=4 SCC2=12	10	SCC1=10 SCC2=5	650	SCC1=2000 SCC2=5035	50 RB with RBstart=0	50 RB with RBstart=0	50 RB with RBstart=0	25 RB with RBstart=0
					900	SCC1=2175 SCC2=5095	50 RB with RBstart=0	50 RB with RBstart=0	50 RB with RBstart=0	25 RB with RBstart=0
					1150	SCC1=2350 SCC2=5155	50 RB with RBstart=0	50 RB with RBstart=0	50 RB with RBstart=0	25 RB with RBstart=0
CA_2A-4A-13A ⁵	2	SCC1=4 SCC2=13	10	SCC1=10 SCC2=10	650	SCC1=2000 SCC2=5230	50 RB with RBstart=0	50 RB with RBstart=0	50 RB with RBstart=0	50 RB with RBstart=0
					900	SCC1=2175 SCC2=5230	50 RB with RBstart=0	50 RB with RBstart=0	50 RB with RBstart=0	50 RB with RBstart=0
					1150	SCC1=2350 SCC2=5230	50 RB with RBstart=0	50 RB with RBstart=0	50 RB with RBstart=0	50 RB with RBstart=0
CA_2A-5A-30A	2	SCC1=5 SCC2=30	10	SCC1=10 SCC2=10	650	SCC1=2450 SCC2=9820	50 RB with RBstart=0	50 RB with RBstart=0	50 RB with RBstart=0	50 RB with RBstart=0
					900	SCC1=2525 SCC2=9820	50 RB with RBstart=0	50 RB with RBstart=0	50 RB with RBstart=0	50 RB with RBstart=0
					1150	SCC1=2600 SCC2=9820	50 RB with RBstart=0	50 RB with RBstart=0	50 RB with RBstart=0	50 RB with RBstart=0
CA_2A-5A-48A	2	SCC1=5 SCC2=48	10	SCC1=10 SCC2=10	650	SCC1=2450 SCC2=55290	50 RB with RBstart=0	50 RB with RBstart=0	50 RB with RBstart=0	50 RB with RBstart=0
					900	SCC1=2525 SCC2=55990	50 RB with RBstart=0	50 RB with RBstart=0	50 RB with RBstart=0	50 RB with RBstart=0
					1150	SCC1=2600 SCC2=56690	50 RB with RBstart=0	50 RB with RBstart=0	50 RB with RBstart=0	50 RB with RBstart=0
CA_2A-5A-66A ⁵	2	SCC1=5 SCC2=66	10	SCC1=10 SCC2=10	650	SCC1=2450 SCC2=66486	50 RB with RBstart=0	50 RB with RBstart=0	50 RB with RBstart=0	50 RB with RBstart=0
					900	SCC1=2525 SCC2=66786	50 RB with RBstart=0	50 RB with RBstart=0	50 RB with RBstart=0	50 RB with RBstart=0
					900	SCC1=2525 SCC2=67086 ⁶	50 RB with RBstart=0	50 RB with RBstart=0	50 RB with RBstart=0	50 RB with RBstart=0
					1150	SCC1=2600 SCC2=67286	50 RB with RBstart=0	50 RB with RBstart=0	50 RB with RBstart=0	50 RB with RBstart=0

TABLE 6-27 LTE CARRIER AGGREGATION MODE (3 DOWNLINK CARRIERS, 1 UPLINK CARRIER) TIS MEASUREMENTS
TABLE FOR THE PRIMARY MECHANICAL MODE¹

Carrier Aggregation Combination	Primary Component Carrier (PCC) Band	Secondary Component Carriers (SCC1/SCC2) Bands	PCC BW (MHz)	SCC BWs (MHz)	PCC Channel	SCC Channels	PCC UL RB Allocation	PCC DL RB Allocation	SCC1 DL RB Allocation	SCC2 DL RB Allocation
CA_2A-12A-30A	2	SCC1=12 SCC2=30	10	SCC1=5 SCC2=10	650	SCC1=5035 SCC2=9820	50 RB with RBstart=0	50 RB with RBstart=0	25 RB with RBstart=0	50 RB with RBstart=0
					900	SCC1=5095 SCC2=9820	50 RB with RBstart=0	50 RB with RBstart=0	25 RB with RBstart=0	50 RB with RBstart=0
					1150	SCC1=5155 SCC2=9820	50 RB with RBstart=0	50 RB with RBstart=0	25 RB with RBstart=0	50 RB with RBstart=0
CA_2A-12A-66A ⁵	2	SCC1=12 SCC2=66	10	SCC1=5 SCC2=10	650	SCC1=5035 SCC2=66486	50 RB with RBstart=0	50 RB with RBstart=0	25 RB with RBstart=0	50 RB with RBstart=0
					900	SCC1=5095 SCC2=66786	50 RB with RBstart=0	50 RB with RBstart=0	25 RB with RBstart=0	50 RB with RBstart=0
					900	SCC1=5095 SCC2=67086 ⁶	50 RB with RBstart=0	50 RB with RBstart=0	25 RB with RBstart=0	50 RB with RBstart=0
					1150	SCC1=5155 SCC2=67286	50 RB with RBstart=0	50 RB with RBstart=0	25 RB with RBstart=0	50 RB with RBstart=0
CA_2A-13A-48A	2	SCC1=13 SCC2=48	10	SCC1=10 SCC2=10	650	SCC1=5230 SCC2=55290	50 RB with RBstart=0	50 RB with RBstart=0	50 RB with RBstart=0	50 RB with RBstart=0
					900	SCC1=5230 SCC2=55990	50 RB with RBstart=0	50 RB with RBstart=0	50 RB with RBstart=0	50 RB with RBstart=0
					1150	SCC1=5230 SCC2=56690	50 RB with RBstart=0	50 RB with RBstart=0	50 RB with RBstart=0	50 RB with RBstart=0
CA_2A-13A-66A ⁵	2	SCC1=13 SCC2=66	10	SCC1=10 SCC2=10	650	SCC1=5230 SCC2=66486	50 RB with RBstart=0	50 RB with RBstart=0	50 RB with RBstart=0	50 RB with RBstart=0
					900	SCC1=5230 SCC2=66786	50 RB with RBstart=0	50 RB with RBstart=0	50 RB with RBstart=0	50 RB with RBstart=0
					900	SCC1=5230 SCC2=67086 ⁶	50 RB with RBstart=0	50 RB with RBstart=0	50 RB with RBstart=0	50 RB with RBstart=0
					1150	SCC1=5230 SCC2=67286	50 RB with RBstart=0	50 RB with RBstart=0	50 RB with RBstart=0	50 RB with RBstart=0
CA_2A-29A-30A	2	SCC1=29 SCC2=30	10	SCC1=10 SCC2=10	650	SCC1=9720 SCC2=9820	50 RB with RBstart=0	50 RB with RBstart=0	50 RB with RBstart=0	50 RB with RBstart=0
					900	SCC1=9720 SCC2=9820	50 RB with RBstart=0	50 RB with RBstart=0	50 RB with RBstart=0	50 RB with RBstart=0
					1150	SCC1=9720 SCC2=9820	50 RB with RBstart=0	50 RB with RBstart=0	50 RB with RBstart=0	50 RB with RBstart=0
CA_2A-48A-66A	2	SCC1=48 SCC2=66	10	SCC1=10 SCC2=10	650	SCC1=55290 SCC2=66486	50 RB with RBstart=0	50 RB with RBstart=0	50 RB with RBstart=0	50 RB with RBstart=0
					900	SCC1=55990 SCC2=66786	50 RB with RBstart=0	50 RB with RBstart=0	50 RB with RBstart=0	50 RB with RBstart=0
					900	SCC1=55990 SCC2=67086 ⁶	50 RB with RBstart=0	50 RB with RBstart=0	50 RB with RBstart=0	50 RB with RBstart=0
					1150	SCC1=56690 SCC2=67286	50 RB with RBstart=0	50 RB with RBstart=0	50 RB with RBstart=0	50 RB with RBstart=0

TABLE 6-27 LTE CARRIER AGGREGATION MODE (3 DOWNLINK CARRIERS, 1 UPLINK CARRIER) TIS MEASUREMENTS
TABLE FOR THE PRIMARY MECHANICAL MODE¹

Carrier Aggregation Combination	Primary Component Carrier (PCC) Band	Secondary Component Carriers (SCC1/SCC2) Bands	PCC BW (MHz)	SCC BWs (MHz)	PCC Channel	SCC Channels	PCC UL RB Allocation	PCC DL RB Allocation	SCC1 DL RB Allocation	SCC2 DL RB Allocation
CA_2A-66C ^{5,7}	2	SCC1=66 SCC2=66	10	SCC1=20 SCC2=20	650	SCC1=66536 SCC2=66734 ⁸	50 RB with RBstart=0	50 RB with RBstart=0	100 RB with RBstart=0	100 RB with RBstart=0
					900	SCC1=66786 SCC2=66984 ⁹	50 RB with RBstart=0	50 RB with RBstart=0	100 RB with RBstart=0	100 RB with RBstart=0
					1150	SCC1=67036 SCC2=67234	50 RB with RBstart=0	50 RB with RBstart=0	100 RB with RBstart=0	100 RB with RBstart=0
CA_2A-66A-66A ⁵	2	SCC1=66 SCC2=66	10	SCC1=10 SCC2=10	650	SCC1=66486 SCC2=67286	50 RB with RBstart=0	50 RB with RBstart=0	50 RB with RBstart=0	50 RB with RBstart=0
					900	SCC1=66486 SCC2=67086 ⁶	50 RB with RBstart=0	50 RB with RBstart=0	50 RB with RBstart=0	50 RB with RBstart=0
					900	SCC1=66786 SCC2=66486	50 RB with RBstart=0	50 RB with RBstart=0	50 RB with RBstart=0	50 RB with RBstart=0
					1150	SCC1=67286 SCC2=66786	50 RB with RBstart=0	50 RB with RBstart=0	50 RB with RBstart=0	50 RB with RBstart=0
CA_4A-2A-4A ⁵	4	SCC1=2 SCC2=4	10	SCC1=10 SCC2=10	2000	SCC1=650 SCC2=2175	50 RB with RBstart=0	50 RB with RBstart=0	50 RB with RBstart=0	50 RB with RBstart=0
					2175	SCC1=900 SCC2=2350	50 RB with RBstart=0	50 RB with RBstart=0	50 RB with RBstart=0	50 RB with RBstart=0
					2350	SCC1=1150 SCC2=2000	50 RB with RBstart=0	50 RB with RBstart=0	50 RB with RBstart=0	50 RB with RBstart=0
CA_4A-2A-5A ⁵	4	SCC1=2 SCC2=5	10	SCC1=10 SCC2=10	2000	SCC1=650 SCC2=2450	50 RB with RBstart=0	50 RB with RBstart=0	50 RB with RBstart=0	50 RB with RBstart=0
					2175	SCC1=900 SCC2=2525	50 RB with RBstart=0	50 RB with RBstart=0	50 RB with RBstart=0	50 RB with RBstart=0
					2350	SCC1=1150 SCC2=2600	50 RB with RBstart=0	50 RB with RBstart=0	50 RB with RBstart=0	50 RB with RBstart=0
CA_4A-2A-12A ⁵	4	SCC1=2 SCC2=12	10	SCC1=10 SCC2=5	2000	SCC1=650 SCC2=5035	50 RB with RBstart=0	50 RB with RBstart=0	50 RB with RBstart=0	25 RB with RBstart=0
					2175	SCC1=900 SCC2=5095	50 RB with RBstart=0	50 RB with RBstart=0	50 RB with RBstart=0	25 RB with RBstart=0
					2350	SCC1=1150 SCC2=5155	50 RB with RBstart=0	50 RB with RBstart=0	50 RB with RBstart=0	25 RB with RBstart=0
CA_4A-2A-13A ⁵	4	SCC1=2 SCC2=13	10	SCC1=10 SCC2=10	2000	SCC1=650 SCC2=5230	50 RB with RBstart=0	50 RB with RBstart=0	50 RB with RBstart=0	50 RB with RBstart=0
					2175	SCC1=900 SCC2=5230	50 RB with RBstart=0	50 RB with RBstart=0	50 RB with RBstart=0	50 RB with RBstart=0
					2350	SCC1=1150 SCC2=5230	50 RB with RBstart=0	50 RB with RBstart=0	50 RB with RBstart=0	50 RB with RBstart=0

TABLE 6-27 LTE CARRIER AGGREGATION MODE (3 DOWNLINK CARRIERS, 1 UPLINK CARRIER) TIS MEASUREMENTS
TABLE FOR THE PRIMARY MECHANICAL MODE¹

Carrier Aggregation Combination	Primary Component Carrier (PCC) Band	Secondary Component Carriers (SCC1/SCC2) Bands	PCC BW (MHz)	SCC BWs (MHz)	PCC Channel	SCC Channels	PCC UL RB Allocation	PCC DL RB Allocation	SCC1 DL RB Allocation	SCC2 DL RB Allocation
CA_4A-4A-5A ⁵	4	SCC1=4 SCC2=5	10	SCC1=10 SCC2=10	2000	SCC1=2175 SCC2=2450	50 RB with RBstart=0	50 RB with RBstart=0	50 RB with RBstart=0	50 RB with RBstart=0
					2175	SCC1=2350 SCC2=2525	50 RB with RBstart=0	50 RB with RBstart=0	50 RB with RBstart=0	50 RB with RBstart=0
					2350	SCC1=2000 SCC2=2600	50 RB with RBstart=0	50 RB with RBstart=0	50 RB with RBstart=0	50 RB with RBstart=0
CA_4A-4A-12A ⁵	4	SCC1=4 SCC2=12	10	SCC1=10 SCC2=5	2000	SCC1=2175 SCC2=5035	50 RB with RBstart=0	50 RB with RBstart=0	50 RB with RBstart=0	25 RB with RBstart=0
					2175	SCC1=2350 SCC2=5095	50 RB with RBstart=0	50 RB with RBstart=0	50 RB with RBstart=0	25 RB with RBstart=0
					2350	SCC1=2000 SCC2=5155	50 RB with RBstart=0	50 RB with RBstart=0	50 RB with RBstart=0	25 RB with RBstart=0
CA_4A-4A-13A ⁵	4	SCC1=4 SCC2=13	10	SCC1=10 SCC2=10	2000	SCC1=2175 SCC2=5230	50 RB with RBstart=0	50 RB with RBstart=0	50 RB with RBstart=0	50 RB with RBstart=0
					2175	SCC1=2350 SCC2=5230	50 RB with RBstart=0	50 RB with RBstart=0	50 RB with RBstart=0	50 RB with RBstart=0
					2350	SCC1=2000 SCC2=5230	50 RB with RBstart=0	50 RB with RBstart=0	50 RB with RBstart=0	50 RB with RBstart=0
CA_4A-5A-30A ⁵	4	SCC1=5 SCC2=30	10	SCC1=10 SCC2=10	2000	SCC1=2450 SCC2=9820	50 RB with RBstart=0	50 RB with RBstart=0	50 RB with RBstart=0	50 RB with RBstart=0
					2175	SCC1=2525 SCC2=9820	50 RB with RBstart=0	50 RB with RBstart=0	50 RB with RBstart=0	50 RB with RBstart=0
					2350	SCC1=2600 SCC2=9820	50 RB with RBstart=0	50 RB with RBstart=0	50 RB with RBstart=0	50 RB with RBstart=0
CA_4A-12A-30A ⁵	4	SCC1=12 SCC2=30	10	SCC1=5 SCC2=10	2000	SCC1=5035 SCC2=9820	50 RB with RBstart=0	50 RB with RBstart=0	25 RB with RBstart=0	50 RB with RBstart=0
					2175	SCC1=5095 SCC2=9820	50 RB with RBstart=0	50 RB with RBstart=0	25 RB with RBstart=0	50 RB with RBstart=0
					2350	SCC1=5155 SCC2=9820	50 RB with RBstart=0	50 RB with RBstart=0	25 RB with RBstart=0	50 RB with RBstart=0
CA_4A-29A-30A ⁵	4	SCC1=29 SCC2=30	10	SCC1=10 SCC2=10	2000	SCC1=9720 SCC2=9820	50 RB with RBstart=0	50 RB with RBstart=0	50 RB with RBstart=0	50 RB with RBstart=0
					2175	SCC1=9720 SCC2=9820	50 RB with RBstart=0	50 RB with RBstart=0	50 RB with RBstart=0	50 RB with RBstart=0
					2350	SCC1=9720 SCC2=9820	50 RB with RBstart=0	50 RB with RBstart=0	50 RB with RBstart=0	50 RB with RBstart=0
CA_5A-2A-2A	5	SCC1=2 SCC2=2	10	SCC1=10 SCC2=10	2450	SCC1=650 SCC2=900	25 RB with RBstart=25	50 RB with RBstart=0	50 RB with RBstart=0	50 RB with RBstart=0
					2525	SCC1=900 SCC2=1150	25 RB with RBstart=25	50 RB with RBstart=0	50 RB with RBstart=0	50 RB with RBstart=0
					2600	SCC1=1150 SCC2=650	25 RB with RBstart=25	50 RB with RBstart=0	50 RB with RBstart=0	50 RB with RBstart=0

TABLE 6-27 LTE CARRIER AGGREGATION MODE (3 DOWNLINK CARRIERS, 1 UPLINK CARRIER) TIS MEASUREMENTS
TABLE FOR THE PRIMARY MECHANICAL MODE¹

Carrier Aggregation Combination	Primary Component Carrier (PCC) Band	Secondary Component Carriers (SCC1/SCC2) Bands	PCC BW (MHz)	SCC BWs (MHz)	PCC Channel	SCC Channels	PCC UL RB Allocation	PCC DL RB Allocation	SCC1 DL RB Allocation	SCC2 DL RB Allocation
CA_5A-2A-4A ⁵	5	SCC1=2 SCC2=4	10	SCC1=10 SCC2=10	2450	SCC1=650 SCC2=2000	25 RB with RBstart=25	50 RB with RBstart=0	50 RB with RBstart=0	50 RB with RBstart=0
					2525	SCC1=900 SCC2=2175	25 RB with RBstart=25	50 RB with RBstart=0	50 RB with RBstart=0	50 RB with RBstart=0
					2600	SCC1=1150 SCC2=2350	25 RB with RBstart=25	50 RB with RBstart=0	50 RB with RBstart=0	50 RB with RBstart=0
CA_5A-2A-30A	5	SCC1=2 SCC2=30	10	SCC1=10 SCC2=10	2450	SCC1=650 SCC2=9820	25 RB with RBstart=25	50 RB with RBstart=0	50 RB with RBstart=0	50 RB with RBstart=0
					2525	SCC1=900 SCC2=9820	25 RB with RBstart=25	50 RB with RBstart=0	50 RB with RBstart=0	50 RB with RBstart=0
					2600	SCC1=1150 SCC2=9820	25 RB with RBstart=25	50 RB with RBstart=0	50 RB with RBstart=0	50 RB with RBstart=0
CA_5A-2A-48A	5	SCC1=2 SCC2=48	10	SCC1=10 SCC2=10	2450	SCC1=650 SCC2=55290	25 RB with RBstart=25	50 RB with RBstart=0	50 RB with RBstart=0	50 RB with RBstart=0
					2525	SCC1=900 SCC2=55990	25 RB with RBstart=25	50 RB with RBstart=0	50 RB with RBstart=0	50 RB with RBstart=0
					2600	SCC1=1150 SCC2=56690	25 RB with RBstart=25	50 RB with RBstart=0	50 RB with RBstart=0	50 RB with RBstart=0
CA_5A-2A-66A ⁵	5	SCC1=2 SCC2=66	10	SCC1=10 SCC2=10	2450	SCC1=650 SCC2=66486	25 RB with RBstart=25	50 RB with RBstart=0	50 RB with RBstart=0	50 RB with RBstart=0
					2525	SCC1=900 SCC2=66786	25 RB with RBstart=25	50 RB with RBstart=0	50 RB with RBstart=0	50 RB with RBstart=0
					2525	SCC1=900 SCC2=67086 ⁶	25 RB with RBstart=25	50 RB with RBstart=0	50 RB with RBstart=0	50 RB with RBstart=0
					2600	SCC1=1150 SCC2=67286	25 RB with RBstart=25	50 RB with RBstart=0	50 RB with RBstart=0	50 RB with RBstart=0
CA_5A-4A-4A ⁵	5	SCC1=4 SCC2=4	10	SCC1=10 SCC2=10	2450	SCC1=2000 SCC2=2175	25 RB with RBstart=25	50 RB with RBstart=0	50 RB with RBstart=0	50 RB with RBstart=0
					2525	SCC1=2175 SCC2=2350	25 RB with RBstart=25	50 RB with RBstart=0	50 RB with RBstart=0	50 RB with RBstart=0
					2600	SCC1=2350 SCC2=2000	25 RB with RBstart=25	50 RB with RBstart=0	50 RB with RBstart=0	50 RB with RBstart=0
CA_5A-4A-30A ⁵	5	SCC1=4 SCC2=30	10	SCC1=10 SCC2=10	2450	SCC1=2000 SCC2=9820	25 RB with RBstart=25	50 RB with RBstart=0	50 RB with RBstart=0	50 RB with RBstart=0
					2525	SCC1=2175 SCC2=9820	25 RB with RBstart=25	50 RB with RBstart=0	50 RB with RBstart=0	50 RB with RBstart=0
					2600	SCC1=2350 SCC2=9820	25 RB with RBstart=25	50 RB with RBstart=0	50 RB with RBstart=0	50 RB with RBstart=0

TABLE 6-27 LTE CARRIER AGGREGATION MODE (3 DOWNLINK CARRIERS, 1 UPLINK CARRIER) TIS MEASUREMENTS
TABLE FOR THE PRIMARY MECHANICAL MODE¹

Carrier Aggregation Combination	Primary Component Carrier (PCC) Band	Secondary Component Carriers (SCC1/SCC2) Bands	PCC BW (MHz)	SCC BWs (MHz)	PCC Channel	SCC Channels	PCC UL RB Allocation	PCC DL RB Allocation	SCC1 DL RB Allocation	SCC2 DL RB Allocation
CA_5A-5A-66A ^{2,5,10}	5	SCC1=5 SCC2=66	5	SCC1=5 SCC2=10	2425	SCC1=2525 SCC2=66486	25 RB with RBstart=0	25 RB with RBstart=0	25 RB with RBstart=0	50 RB with RBstart=0
					2525	SCC1=2625 SCC2=66786	25 RB with RBstart=0	25 RB with RBstart=0	25 RB with RBstart=0	50 RB with RBstart=0
					2625	SCC1=2425 SCC2=67086 ⁶	12 RB with RBstart=13	25 RB with RBstart=0	25 RB with RBstart=0	50 RB with RBstart=0
					2425 ¹¹	SCC1=2625 SCC2=67286	25 RB with RBstart=0	25 RB with RBstart=0	25 RB with RBstart=0	50 RB with RBstart=0
CA_5A-29A-30A	5	SCC1=29 SCC2=30	10	SCC1=10 SCC2=10	2450	SCC1=9720 SCC2=9820	25 RB with RBstart=25	50 RB with RBstart=0	50 RB with RBstart=0	50 RB with RBstart=0
					2525	SCC1=9720 SCC2=9820	25 RB with RBstart=25	50 RB with RBstart=0	50 RB with RBstart=0	50 RB with RBstart=0
					2600	SCC1=9720 SCC2=9820	25 RB with RBstart=25	50 RB with RBstart=0	50 RB with RBstart=0	50 RB with RBstart=0
CA_5A-30A-66A ⁵	5	SCC1=30 SCC2=66	10	SCC1=10 SCC2=10	2450	SCC1=9820 SCC2=66486	25 RB with RBstart=25	50 RB with RBstart=0	50 RB with RBstart=0	50 RB with RBstart=0
					2525	SCC1=9820 SCC2=66786	25 RB with RBstart=25	50 RB with RBstart=0	50 RB with RBstart=0	50 RB with RBstart=0
					2525	SCC1=9820 SCC2=67086 ⁶	25 RB with RBstart=25	50 RB with RBstart=0	50 RB with RBstart=0	50 RB with RBstart=0
					2600	SCC1=9820 SCC2=67286	25 RB with RBstart=25	50 RB with RBstart=0	50 RB with RBstart=0	50 RB with RBstart=0
CA_5A-48A-66A	5	SCC1=48 SCC2=66	10	SCC1=10 SCC2=10	2450	SCC1=55290 SCC2=66486	25 RB with RBstart=25	50 RB with RBstart=0	50 RB with RBstart=0	50 RB with RBstart=0
					2525	SCC1=55990 SCC2=66786	25 RB with RBstart=25	50 RB with RBstart=0	50 RB with RBstart=0	50 RB with RBstart=0
					2525	SCC1=55990 SCC2=67086 ⁶	25 RB with RBstart=25	50 RB with RBstart=0	50 RB with RBstart=0	50 RB with RBstart=0
					2600	SCC1=56690 SCC2=67286	25 RB with RBstart=25	50 RB with RBstart=0	50 RB with RBstart=0	50 RB with RBstart=0
CA_5A-66C ^{5,7}	5	SCC1=66 SCC2=66	10	SCC1=20 SCC2=20	2450	SCC1=66536 SCC2=66734 ⁸	25 RB with RBstart=25	50 RB with RBstart=0	100 RB with RBstart=0	100 RB with RBstart=0
					2525	SCC1=66786 SCC2=66984 ⁹	25 RB with RBstart=25	50 RB with RBstart=0	100 RB with RBstart=0	100 RB with RBstart=0
					2600	SCC1=67036 SCC2=67234	25 RB with RBstart=25	50 RB with RBstart=0	100 RB with RBstart=0	100 RB with RBstart=0

TABLE 6-27 LTE CARRIER AGGREGATION MODE (3 DOWNLINK CARRIERS, 1 UPLINK CARRIER) TIS MEASUREMENTS
TABLE FOR THE PRIMARY MECHANICAL MODE¹

Carrier Aggregation Combination	Primary Component Carrier (PCC) Band	Secondary Component Carriers (SCC1/ SCC2) Bands	PCC BW (MHz)	SCC BWs (MHz)	PCC Channel	SCC Channels	PCC UL RB Allocation	PCC DL RB Allocation	SCC1 DL RB Allocation	SCC2 DL RB Allocation
CA_5A-66A-66A ⁵	5	SCC1=66 SCC2=66	10	SCC1=10 SCC2=10	2450	SCC1=66486 SCC2=67286	25 RB with RBstart=25	50 RB with RBstart=0	50 RB with RBstart=0	50 RB with RBstart=0
					2525	SCC1=66486 SCC2=67086 ⁶	25 RB with RBstart=25	50 RB with RBstart=0	50 RB with RBstart=0	50 RB with RBstart=0
					2525	SCC1=66786 SCC2=66486	25 RB with RBstart=25	50 RB with RBstart=0	50 RB with RBstart=0	50 RB with RBstart=0
					2600	SCC1=67286 SCC2=66786	25 RB with RBstart=25	50 RB with RBstart=0	50 RB with RBstart=0	50 RB with RBstart=0
CA_12A-2A-2A	12	SCC1=2 SCC2=2	5	SCC1=10 SCC2=10	5035	SCC1=650 SCC2=900	20 RB with RBstart=5	25 RB with RBstart=0	50 RB with RBstart=0	50 RB with RBstart=0
					5095	SCC1=900 SCC2=1150	20 RB with RBstart=5	25 RB with RBstart=0	50 RB with RBstart=0	50 RB with RBstart=0
					5155	SCC1=1150 SCC2=650	20 RB with RBstart=5	25 RB with RBstart=0	50 RB with RBstart=0	50 RB with RBstart=0
CA_12A-2A-4A ^{2,5}	12	SCC1=2 SCC2=4	5	SCC1=10 SCC2=10	5035	SCC1=650 SCC2=2000	20 RB with RBstart=5	25 RB with RBstart=0	50 RB with RBstart=0	50 RB with RBstart=0
					5095	SCC1=900 SCC2=2175	20 RB with RBstart=5	25 RB with RBstart=0	50 RB with RBstart=0	50 RB with RBstart=0
					5155	SCC1=1150 SCC2=2350	20 RB with RBstart=5	25 RB with RBstart=0	50 RB with RBstart=0	50 RB with RBstart=0
CA_12A-2A-30A	12	SCC1=2 SCC2=30	5	SCC1=10 SCC2=10	5035	SCC1=650 SCC2=9820	20 RB with RBstart=5	25 RB with RBstart=0	50 RB with RBstart=0	50 RB with RBstart=0
					5095	SCC1=900 SCC2=9820	20 RB with RBstart=5	25 RB with RBstart=0	50 RB with RBstart=0	50 RB with RBstart=0
					5155	SCC1=1150 SCC2=9820	20 RB with RBstart=5	25 RB with RBstart=0	50 RB with RBstart=0	50 RB with RBstart=0
CA_12A-2A-66A ^{2,5}	12	SCC1=2 SCC2=66	5	SCC1=10 SCC2=10	5035	SCC1=650 SCC2=66486	20 RB with RBstart=5	25 RB with RBstart=0	50 RB with RBstart=0	50 RB with RBstart=0
					5095	SCC1=900 SCC2=66786	20 RB with RBstart=5	25 RB with RBstart=0	50 RB with RBstart=0	50 RB with RBstart=0
					5095	SCC1=900 SCC2=67086 ⁶	20 RB with RBstart=5	25 RB with RBstart=0	50 RB with RBstart=0	50 RB with RBstart=0
					5155	SCC1=1150 SCC2=67286	20 RB with RBstart=5	25 RB with RBstart=0	50 RB with RBstart=0	50 RB with RBstart=0
CA_12A-4A-4A ^{2,5}	12	SCC1=4 SCC2=4	5	SCC1=10 SCC2=10	5035	SCC1=2000 SCC2=2175	20 RB with RBstart=5	25 RB with RBstart=0	50 RB with RBstart=0	50 RB with RBstart=0
					5095	SCC1=2175 SCC2=2350	20 RB with RBstart=5	25 RB with RBstart=0	50 RB with RBstart=0	50 RB with RBstart=0
					5155	SCC1=2350 SCC2=2000	20 RB with RBstart=5	25 RB with RBstart=0	50 RB with RBstart=0	50 RB with RBstart=0

TABLE 6-27 LTE CARRIER AGGREGATION MODE (3 DOWNLINK CARRIERS, 1 UPLINK CARRIER) TIS MEASUREMENTS
TABLE FOR THE PRIMARY MECHANICAL MODE¹

Carrier Aggregation Combination	Primary Component Carrier (PCC) Band	Secondary Component Carriers (SCC1/SCC2) Bands	PCC BW (MHz)	SCC BWs (MHz)	PCC Channel	SCC Channels	PCC UL RB Allocation	PCC DL RB Allocation	SCC1 DL RB Allocation	SCC2 DL RB Allocation
CA_12A-4A-30A ^{2,5}	12	SCC1=4 SCC2=30	5	SCC1=10 SCC2=10	5035	SCC1=2000 SCC2=9820	20 RB with RBstart=5	25 RB with RBstart=0	50 RB with RBstart=0	50 RB with RBstart=0
					5095	SCC1=2175 SCC2=9820	20 RB with RBstart=5	25 RB with RBstart=0	50 RB with RBstart=0	50 RB with RBstart=0
					5155	SCC1=2350 SCC2=9820	20 RB with RBstart=5	25 RB with RBstart=0	50 RB with RBstart=0	50 RB with RBstart=0
CA_12A-29A-66A ^{2,5}	12	SCC1=29 SCC2=66	5	SCC1=10 SCC2=10	5035	SCC1=9720 SCC2=66486	20 RB with RBstart=5	25 RB with RBstart=0	50 RB with RBstart=0	50 RB with RBstart=0
					5095	SCC1=9720 SCC2=66786	20 RB with RBstart=5	25 RB with RBstart=0	50 RB with RBstart=0	50 RB with RBstart=0
					5095	SCC1=9720 SCC2=67086 ⁶	20 RB with RBstart=5	25 RB with RBstart=0	50 RB with RBstart=0	50 RB with RBstart=0
					5155	SCC1=9720 SCC2=67286	20 RB with RBstart=5	25 RB with RBstart=0	50 RB with RBstart=0	50 RB with RBstart=0
CA_12A-30A-66A ^{2,5}	12	SCC1=30 SCC2=66	5	SCC1=10 SCC2=10	5035	SCC1=9820 SCC2=66486	20 RB with RBstart=5	25 RB with RBstart=0	50 RB with RBstart=0	50 RB with RBstart=0
					5095	SCC1=9820 SCC2=66786	20 RB with RBstart=5	25 RB with RBstart=0	50 RB with RBstart=0	50 RB with RBstart=0
					5095	SCC1=9820 SCC2=67086 ⁶	20 RB with RBstart=5	25 RB with RBstart=0	50 RB with RBstart=0	50 RB with RBstart=0
					5155	SCC1=9820 SCC2=67286	20 RB with RBstart=5	25 RB with RBstart=0	50 RB with RBstart=0	50 RB with RBstart=0
CA_12A-66C ^{2,5,7}	12	SCC1=66 SCC2=66	5	SCC1=20 SCC2=20	5035	SCC1=66536 SCC2=66734 ⁸	20 RB with RBstart=5	25 RB with RBstart=0	100 RB with RBstart=0	100 RB with RBstart=0
					5095	SCC1=66786 SCC2=66984 ⁹	20 RB with RBstart=5	25 RB with RBstart=0	100 RB with RBstart=0	100 RB with RBstart=0
					5155	SCC1=67036 SCC2=67234	20 RB with RBstart=5	25 RB with RBstart=0	100 RB with RBstart=0	100 RB with RBstart=0
CA_12A-66A-66A ^{2,5}	12	SCC1=66 SCC2=66	5	SCC1=10 SCC2=10	5035	SCC1=66486 SCC2=67286	20 RB with RBstart=5	25 RB with RBstart=0	50 RB with RBstart=0	50 RB with RBstart=0
					5095	SCC1=66486 SCC2=67086 ⁶	20 RB with RBstart=5	25 RB with RBstart=0	50 RB with RBstart=0	50 RB with RBstart=0
					5095	SCC1=66786 SCC2=66486	20 RB with RBstart=5	25 RB with RBstart=0	50 RB with RBstart=0	50 RB with RBstart=0
					5155	SCC1=67286 SCC2=66786	20 RB with RBstart=5	25 RB with RBstart=0	50 RB with RBstart=0	50 RB with RBstart=0

TABLE 6-27 LTE CARRIER AGGREGATION MODE (3 DOWNLINK CARRIERS, 1 UPLINK CARRIER) TIS MEASUREMENTS
TABLE FOR THE PRIMARY MECHANICAL MODE¹

Carrier Aggregation Combination	Primary Component Carrier (PCC) Band	Secondary Component Carriers (SCC1/SCC2) Bands	PCC BW (MHz)	SCC BWs (MHz)	PCC Channel	SCC Channels	PCC UL RB Allocation	PCC DL RB Allocation	SCC1 DL RB Allocation	SCC2 DL RB Allocation
CA_13A-2A-2A	13	SCC1=2 SCC2=2	10	SCC1=10 SCC2=10	5230	SCC1=650 SCC2=900	15 RB with RBstart=0	50 RB with RBstart=0	50 RB with RBstart=0	50 RB with RBstart=0
					5230	SCC1=900 SCC2=1150	15 RB with RBstart=0	50 RB with RBstart=0	50 RB with RBstart=0	50 RB with RBstart=0
					5230	SCC1=1150 SCC2=650	15 RB with RBstart=0	50 RB with RBstart=0	50 RB with RBstart=0	50 RB with RBstart=0
CA_13A-2A-4A ⁵	13	SCC1=2 SCC2=4	10	SCC1=10 SCC2=10	5230	SCC1=650 SCC2=2000	15 RB with RBstart=0	50 RB with RBstart=0	50 RB with RBstart=0	50 RB with RBstart=0
					5230	SCC1=900 SCC2=2175	15 RB with RBstart=0	50 RB with RBstart=0	50 RB with RBstart=0	50 RB with RBstart=0
					5230	SCC1=1150 SCC2=2350	15 RB with RBstart=0	50 RB with RBstart=0	50 RB with RBstart=0	50 RB with RBstart=0
CA_13A-2A-48A	13	SCC1=2 SCC2=48	10	SCC1=10 SCC2=10	5230	SCC1=650 SCC2=55290	15 RB with RBstart=0	50 RB with RBstart=0	50 RB with RBstart=0	50 RB with RBstart=0
					5230	SCC1=900 SCC2=55990	15 RB with RBstart=0	50 RB with RBstart=0	50 RB with RBstart=0	50 RB with RBstart=0
					5230	SCC1=1150 SCC2=56690	15 RB with RBstart=0	50 RB with RBstart=0	50 RB with RBstart=0	50 RB with RBstart=0
CA_13A-2A-66A ⁵	13	SCC1=2 SCC2=66	10	SCC1=10 SCC2=10	5230	SCC1=650 SCC2=66486	15 RB with RBstart=0	50 RB with RBstart=0	50 RB with RBstart=0	50 RB with RBstart=0
					5230	SCC1=900 SCC2=66786	15 RB with RBstart=0	50 RB with RBstart=0	50 RB with RBstart=0	50 RB with RBstart=0
					5230	SCC1=900 SCC2=67086 ⁶	15 RB with RBstart=0	50 RB with RBstart=0	50 RB with RBstart=0	50 RB with RBstart=0
					5230	SCC1=1150 SCC2=67286	15 RB with RBstart=0	50 RB with RBstart=0	50 RB with RBstart=0	50 RB with RBstart=0
CA_13A-4A-4A ⁵	13	SCC1=4 SCC2=4	10	SCC1=10 SCC2=10	5230	SCC1=2000 SCC2=2175	15 RB with RBstart=0	50 RB with RBstart=0	50 RB with RBstart=0	50 RB with RBstart=0
					5230	SCC1=2175 SCC2=2350	15 RB with RBstart=0	50 RB with RBstart=0	50 RB with RBstart=0	50 RB with RBstart=0
					5230	SCC1=2350 SCC2=2000	15 RB with RBstart=0	50 RB with RBstart=0	50 RB with RBstart=0	50 RB with RBstart=0
CA_13A-48A-66A	13	SCC1=48 SCC2=66	10	SCC1=10 SCC2=10	5230	SCC1=55290 SCC2=66486	15 RB with RBstart=0	50 RB with RBstart=0	50 RB with RBstart=0	50 RB with RBstart=0
					5230	SCC1=55990 SCC2=66786	15 RB with RBstart=0	50 RB with RBstart=0	50 RB with RBstart=0	50 RB with RBstart=0
					5230	SCC1=55990 SCC2=67086 ⁶	15 RB with RBstart=0	50 RB with RBstart=0	50 RB with RBstart=0	50 RB with RBstart=0
					5230	SCC1=56690 SCC2=67286	15 RB with RBstart=0	50 RB with RBstart=0	50 RB with RBstart=0	50 RB with RBstart=0

TABLE 6-27 LTE CARRIER AGGREGATION MODE (3 DOWNLINK CARRIERS, 1 UPLINK CARRIER) TIS MEASUREMENTS
TABLE FOR THE PRIMARY MECHANICAL MODE¹

Carrier Aggregation Combination	Primary Component Carrier (PCC) Band	Secondary Component Carriers (SCC1/ SCC2) Bands	PCC BW (MHz)	SCC BWs (MHz)	PCC Channel	SCC Channels	PCC UL RB Allocation	PCC DL RB Allocation	SCC1 DL RB Allocation	SCC2 DL RB Allocation
CA_13A-66C ^{5,7}	13	SCC1=66 SCC2=66	10	SCC1=20 SCC2=20	5230	SCC1=66536 SCC2=66734 ⁸	15 RB with RBstart=0	50 RB with RBstart=0	100 RB with RBstart=0	100 RB with RBstart=0
					5230	SCC1=66786 SCC2=66984 ⁹	15 RB with RBstart=0	50 RB with RBstart=0	100 RB with RBstart=0	100 RB with RBstart=0
					5230	SCC1=67036 SCC2=67234	15 RB with RBstart=0	50 RB with RBstart=0	100 RB with RBstart=0	100 RB with RBstart=0
CA_13A-66A-66A ⁵	13	SCC1=66 SCC2=66	10	SCC1=10 SCC2=10	5230	SCC1=66486 SCC2=67286	15 RB with RBstart=0	50 RB with RBstart=0	50 RB with RBstart=0	50 RB with RBstart=0
					5230	SCC1=66486 SCC2=67086 ⁶	15 RB with RBstart=0	50 RB with RBstart=0	50 RB with RBstart=0	50 RB with RBstart=0
					5230	SCC1=66786 SCC2=66486	15 RB with RBstart=0	50 RB with RBstart=0	50 RB with RBstart=0	50 RB with RBstart=0
					5230	SCC1=67286 SCC2=66786	15 RB with RBstart=0	50 RB with RBstart=0	50 RB with RBstart=0	50 RB with RBstart=0
CA_25A-41C	25	SCC1=41 SCC2=41	5	SCC1=20 SCC2=20	8065	SCC1=39750 SCC2=39948	25 RB with RBstart=0	25 RB with RBstart=0	100 RB with RBstart=0	100 RB with RBstart=0
					8365	SCC1=40620 SCC2=40422	25 RB with RBstart=0	25 RB with RBstart=0	100 RB with RBstart=0	100 RB with RBstart=0
					8665	SCC1=41490 SCC2=41292	25 RB with RBstart=0	25 RB with RBstart=0	100 RB with RBstart=0	100 RB with RBstart=0
CA_30A-2A-5A	30	SCC1=2 SCC2=5	10	SCC1=10 SCC2=10	9820	SCC1=650 SCC2=2450	25 RB with RBstart=25	50 RB with RBstart=0	50 RB with RBstart=0	50 RB with RBstart=0
					9820	SCC1=900 SCC2=2525	25 RB with RBstart=25	50 RB with RBstart=0	50 RB with RBstart=0	50 RB with RBstart=0
					9820	SCC1=1150 SCC2=2600	25 RB with RBstart=25	50 RB with RBstart=0	50 RB with RBstart=0	50 RB with RBstart=0
CA_30A-2A-12A	30	SCC1=2 SCC2=12	10	SCC1=10 SCC2=5	9820	SCC1=650 SCC2=5035	25 RB with RBstart=25	50 RB with RBstart=0	50 RB with RBstart=0	25 RB with RBstart=0
					9820	SCC1=900 SCC2=5095	25 RB with RBstart=25	50 RB with RBstart=0	50 RB with RBstart=0	25 RB with RBstart=0
					9820	SCC1=1150 SCC2=5155	25 RB with RBstart=25	50 RB with RBstart=0	50 RB with RBstart=0	25 RB with RBstart=0

TABLE 6-27 LTE CARRIER AGGREGATION MODE (3 DOWNLINK CARRIERS, 1 UPLINK CARRIER) TIS MEASUREMENTS
TABLE FOR THE PRIMARY MECHANICAL MODE¹

Carrier Aggregation Combination	Primary Component Carrier (PCC) Band	Secondary Component Carriers (SCC1/SCC2) Bands	PCC BW (MHz)	SCC BWs (MHz)	PCC Channel	SCC Channels	PCC UL RB Allocation	PCC DL RB Allocation	SCC1 DL RB Allocation	SCC2 DL RB Allocation
CA_30A-2A-29A	30	SCC1=2 SCC2=29	10	SCC1=10 SCC2=10	9820	SCC1=650 SCC2=9720	25 RB with RBstart=25	50 RB with RBstart=0	50 RB with RBstart=0	50 RB with RBstart=0
					9820	SCC1=900 SCC2=9720	25 RB with RBstart=25	50 RB with RBstart=0	50 RB with RBstart=0	50 RB with RBstart=0
					9820	SCC1=1150 SCC2=9720	25 RB with RBstart=25	50 RB with RBstart=0	50 RB with RBstart=0	50 RB with RBstart=0
CA_30A-4A-5A ⁵	30	SCC1=4 SCC2=5	10	SCC1=10 SCC2=10	9820	SCC1=2000 SCC2=2450	25 RB with RBstart=25	50 RB with RBstart=0	50 RB with RBstart=0	50 RB with RBstart=0
					9820	SCC1=2175 SCC2=2525	25 RB with RBstart=25	50 RB with RBstart=0	50 RB with RBstart=0	50 RB with RBstart=0
					9820	SCC1=2350 SCC2=2600	25 RB with RBstart=25	50 RB with RBstart=0	50 RB with RBstart=0	50 RB with RBstart=0
CA_30A-4A-12A ⁵	30	SCC1=4 SCC2=12	10	SCC1=10 SCC2=5	9820	SCC1=2000 SCC2=5035	25 RB with RBstart=25	50 RB with RBstart=0	50 RB with RBstart=0	25 RB with RBstart=0
					9820	SCC1=2175 SCC2=5095	25 RB with RBstart=25	50 RB with RBstart=0	50 RB with RBstart=0	25 RB with RBstart=0
					9820	SCC1=2350 SCC2=5155	25 RB with RBstart=25	50 RB with RBstart=0	50 RB with RBstart=0	25 RB with RBstart=0
CA_30A-4A-29A ⁵	30	SCC1=4 SCC2=29	10	SCC1=10 SCC2=10	9820	SCC1=2000 SCC2=9720	25 RB with RBstart=25	50 RB with RBstart=0	50 RB with RBstart=0	50 RB with RBstart=0
					9820	SCC1=2175 SCC2=9720	25 RB with RBstart=25	50 RB with RBstart=0	50 RB with RBstart=0	50 RB with RBstart=0
					9820	SCC1=2350 SCC2=9720	25 RB with RBstart=25	50 RB with RBstart=0	50 RB with RBstart=0	50 RB with RBstart=0
CA_30A-5A-29A ⁵	30	SCC1=5 SCC2=29	10	SCC1=10 SCC2=10	9820	SCC1=2450 SCC2=9720	25 RB with RBstart=25	50 RB with RBstart=0	50 RB with RBstart=0	50 RB with RBstart=0
					9820	SCC1=2525 SCC2=9720	25 RB with RBstart=25	50 RB with RBstart=0	50 RB with RBstart=0	50 RB with RBstart=0
					9820	SCC1=2600 SCC2=9720	25 RB with RBstart=25	50 RB with RBstart=0	50 RB with RBstart=0	50 RB with RBstart=0
CA_30A-5A-66A ⁵	30	SCC1=5 SCC2=66	10	SCC1=10 SCC2=10	9820	SCC1=2450 SCC2=66486	25 RB with RBstart=25	50 RB with RBstart=0	50 RB with RBstart=0	50 RB with RBstart=0
					9820	SCC1=2525 SCC2=66786	25 RB with RBstart=25	50 RB with RBstart=0	50 RB with RBstart=0	50 RB with RBstart=0
					9820	SCC1=2525 SCC2=67086 ⁶	25 RB with RBstart=25	50 RB with RBstart=0	50 RB with RBstart=0	50 RB with RBstart=0
					9820	SCC1=2600 SCC2=67286	25 RB with RBstart=25	50 RB with RBstart=0	50 RB with RBstart=0	50 RB with RBstart=0

TABLE 6-27 LTE CARRIER AGGREGATION MODE (3 DOWNLINK CARRIERS, 1 UPLINK CARRIER) TIS MEASUREMENTS
TABLE FOR THE PRIMARY MECHANICAL MODE¹

Carrier Aggregation Combination	Primary Component Carrier (PCC) Band	Secondary Component Carriers (SCC1/SCC2) Bands	PCC BW (MHz)	SCC BWs (MHz)	PCC Channel	SCC Channels	PCC UL RB Allocation	PCC DL RB Allocation	SCC1 DL RB Allocation	SCC2 DL RB Allocation
CA_30A-12A-66A ⁵	30	SCC1=12 SCC2=66	10	SCC1=5 SCC2=10	9820	SCC1=5035 SCC2=66486	25 RB with RBstart=25	50 RB with RBstart=0	25 RB with RBstart=0	50 RB with RBstart=0
					9820	SCC1=5095 SCC2=66786	25 RB with RBstart=25	50 RB with RBstart=0	25 RB with RBstart=0	50 RB with RBstart=0
					9820	SCC1=5095 SCC2=67086 ⁶	25 RB with RBstart=25	50 RB with RBstart=0	25 RB with RBstart=0	50 RB with RBstart=0
					9820	SCC1=5155 SCC2=67286	25 RB with RBstart=25	50 RB with RBstart=0	25 RB with RBstart=0	50 RB with RBstart=0
CA_30A-29A-66A ⁵	30	SCC1=29 SCC2=66	10	SCC1=10 SCC2=10	9820	SCC1=9720 SCC2=66486	25 RB with RBstart=25	50 RB with RBstart=0	50 RB with RBstart=0	50 RB with RBstart=0
					9820	SCC1=9720 SCC2=66786	25 RB with RBstart=25	50 RB with RBstart=0	50 RB with RBstart=0	50 RB with RBstart=0
					9820	SCC1=9720 SCC2=67086 ⁶	25 RB with RBstart=25	50 RB with RBstart=0	50 RB with RBstart=0	50 RB with RBstart=0
					9820	SCC1=9720 SCC2=67286	25 RB with RBstart=25	50 RB with RBstart=0	50 RB with RBstart=0	50 RB with RBstart=0
CA_30A-66C ^{5,7}	30	SCC1=66 SCC2=66	10	SCC1=20 SCC2=20	9820	SCC1=66536 SCC2=66734 ⁸	25 RB with RBstart=25	50 RB with RBstart=0	100 RB with RBstart=0	100 RB with RBstart=0
					9820	SCC1=66786 SCC2=66984 ⁹	25 RB with RBstart=25	50 RB with RBstart=0	100 RB with RBstart=0	100 RB with RBstart=0
					9820	SCC1=67036 SCC2=67234	25 RB with RBstart=25	50 RB with RBstart=0	100 RB with RBstart=0	100 RB with RBstart=0
CA_30A-66A-66A ⁵	30	SCC1=66 SCC2=66	10	SCC1=10 SCC2=10	9820	SCC1=66486 SCC2=67286	25 RB with RBstart=25	50 RB with RBstart=0	50 RB with RBstart=0	50 RB with RBstart=0
					9820	SCC1=66486 SCC2=67086 ⁶	25 RB with RBstart=25	50 RB with RBstart=0	50 RB with RBstart=0	50 RB with RBstart=0
					9820	SCC1=66786 SCC2=66486	25 RB with RBstart=25	50 RB with RBstart=0	50 RB with RBstart=0	50 RB with RBstart=0
					9820	SCC1=67286 SCC2=66786	25 RB with RBstart=25	50 RB with RBstart=0	50 RB with RBstart=0	50 RB with RBstart=0
CA_41D	41	SCC1=41 SCC2=41	20	SCC1=20 SCC2=20	39750	SCC1=39948 ⁸ SCC2=40146 ⁸	100 RB with RBstart=0	100 RB with RBstart=0	100 RB with RBstart=0	100 RB with RBstart=0
					40620	SCC1=40422 ¹² SCC2=40818 ⁹	100 RB with RBstart=0	100 RB with RBstart=0	100 RB with RBstart=0	100 RB with RBstart=0
					41490	SCC1=41292 ⁸ SCC2=41094 ⁸	100 RB with RBstart=0	100 RB with RBstart=0	100 RB with RBstart=0	100 RB with RBstart=0

TABLE 6-27 LTE CARRIER AGGREGATION MODE (3 DOWNLINK CARRIERS, 1 UPLINK CARRIER) TIS MEASUREMENTS
TABLE FOR THE PRIMARY MECHANICAL MODE¹

Carrier Aggregation Combination	Primary Component Carrier (PCC) Band	Secondary Component Carriers (SCC1/SCC2) Bands	PCC BW (MHz)	SCC BWs (MHz)	PCC Channel	SCC Channels	PCC UL RB Allocation	PCC DL RB Allocation	SCC1 DL RB Allocation	SCC2 DL RB Allocation
CA_48A-2A-5A	48	SCC1=2 SCC2=5	10	SCC1=10 SCC2=10	55290	SCC1=650 SCC2=2450	50 RB with RBstart=0	50 RB with RBstart=0	50 RB with RBstart=0	50 RB with RBstart=0
					55990	SCC1=900 SCC2=2525	50 RB with RBstart=0	50 RB with RBstart=0	50 RB with RBstart=0	50 RB with RBstart=0
					56690	SCC1=1150 SCC2=2600	50 RB with RBstart=0	50 RB with RBstart=0	50 RB with RBstart=0	50 RB with RBstart=0
CA_48A-2A-13A	48	SCC1=2 SCC2=13	10	SCC1=10 SCC2=10	55290	SCC1=650 SCC2=5230	50 RB with RBstart=0	50 RB with RBstart=0	50 RB with RBstart=0	50 RB with RBstart=0
					55990	SCC1=900 SCC2=5230	50 RB with RBstart=0	50 RB with RBstart=0	50 RB with RBstart=0	50 RB with RBstart=0
					56690	SCC1=1150 SCC2=5230	50 RB with RBstart=0	50 RB with RBstart=0	50 RB with RBstart=0	50 RB with RBstart=0
CA_48A-2A-66A	48	SCC1=2 SCC2=66	10	SCC1=10 SCC2=10	55290	SCC1=650 SCC2=66486	50 RB with RBstart=0	50 RB with RBstart=0	50 RB with RBstart=0	50 RB with RBstart=0
					55990	SCC1=900 SCC2=66786	50 RB with RBstart=0	50 RB with RBstart=0	50 RB with RBstart=0	50 RB with RBstart=0
					55990	SCC1=900 SCC2=67086 ⁶	50 RB with RBstart=0	50 RB with RBstart=0	50 RB with RBstart=0	50 RB with RBstart=0
					56690	SCC1=1150 SCC2=67286	50 RB with RBstart=0	50 RB with RBstart=0	50 RB with RBstart=0	50 RB with RBstart=0
CA_48A-5A-66A	48	SCC1=5 SCC2=66	10	SCC1=10 SCC2=10	55290	SCC1=2450 SCC2=66486	50 RB with RBstart=0	50 RB with RBstart=0	50 RB with RBstart=0	50 RB with RBstart=0
					55990	SCC1=2525 SCC2=66786	50 RB with RBstart=0	50 RB with RBstart=0	50 RB with RBstart=0	50 RB with RBstart=0
					55990	SCC1=2525 SCC2=67086 ⁶	50 RB with RBstart=0	50 RB with RBstart=0	50 RB with RBstart=0	50 RB with RBstart=0
					56690	SCC1=2600 SCC2=67286	50 RB with RBstart=0	50 RB with RBstart=0	50 RB with RBstart=0	50 RB with RBstart=0
CA_48A-13A-66A	48	SCC1=13 SCC2=66	10	SCC1=10 SCC2=10	55290	SCC1=5230 SCC2=66486	50 RB with RBstart=0	50 RB with RBstart=0	50 RB with RBstart=0	50 RB with RBstart=0
					55990	SCC1=5230 SCC2=66786	50 RB with RBstart=0	50 RB with RBstart=0	50 RB with RBstart=0	50 RB with RBstart=0
					55990	SCC1=5230 SCC2=67086 ⁶	50 RB with RBstart=0	50 RB with RBstart=0	50 RB with RBstart=0	50 RB with RBstart=0
					56690	SCC1=5230 SCC2=67286	50 RB with RBstart=0	50 RB with RBstart=0	50 RB with RBstart=0	50 RB with RBstart=0
CA_66A-2A-2A ⁵	66	SCC1=2 SCC2=2	10	SCC1=10 SCC2=10	66486	SCC1=650 SCC2=900	50 RB with RBstart=0	50 RB with RBstart=0	50 RB with RBstart=0	50 RB with RBstart=0
					66786	SCC1=900 SCC2=1150	50 RB with RBstart=0	50 RB with RBstart=0	50 RB with RBstart=0	50 RB with RBstart=0
					67086	SCC1=1150 SCC2=650	50 RB with RBstart=0	50 RB with RBstart=0	50 RB with RBstart=0	50 RB with RBstart=0

TABLE 6-27 LTE CARRIER AGGREGATION MODE (3 DOWNLINK CARRIERS, 1 UPLINK CARRIER) TIS MEASUREMENTS
TABLE FOR THE PRIMARY MECHANICAL MODE¹

Carrier Aggregation Combination	Primary Component Carrier (PCC) Band	Secondary Component Carriers (SCC1/SCC2) Bands	PCC BW (MHz)	SCC BWs (MHz)	PCC Channel	SCC Channels	PCC UL RB Allocation	PCC DL RB Allocation	SCC1 DL RB Allocation	SCC2 DL RB Allocation
CA_66A-2A-5A ⁵	66	SCC1=2 SCC2=5	10	SCC1=10 SCC2=10	66486	SCC1=650 SCC2=2450	50 RB with RBstart=0	50 RB with RBstart=0	50 RB with RBstart=0	50 RB with RBstart=0
					66786	SCC1=900 SCC2=2525	50 RB with RBstart=0	50 RB with RBstart=0	50 RB with RBstart=0	50 RB with RBstart=0
					67086	SCC1=1150 SCC2=2600	50 RB with RBstart=0	50 RB with RBstart=0	50 RB with RBstart=0	50 RB with RBstart=0
CA_66A-2A-12A ⁵	66	SCC1=2 SCC2=12	10	SCC1=10 SCC2=5	66486	SCC1=650 SCC2=5035	50 RB with RBstart=0	50 RB with RBstart=0	50 RB with RBstart=0	25 RB with RBstart=0
					66786	SCC1=900 SCC2=5095	50 RB with RBstart=0	50 RB with RBstart=0	50 RB with RBstart=0	25 RB with RBstart=0
					67086	SCC1=1150 SCC2=5155	50 RB with RBstart=0	50 RB with RBstart=0	50 RB with RBstart=0	25 RB with RBstart=0
CA_66A-2A-13A ⁵	66	SCC1=2 SCC2=13	10	SCC1=10 SCC2=10	66486	SCC1=650 SCC2=5230	50 RB with RBstart=0	50 RB with RBstart=0	50 RB with RBstart=0	50 RB with RBstart=0
					66786	SCC1=900 SCC2=5230	50 RB with RBstart=0	50 RB with RBstart=0	50 RB with RBstart=0	50 RB with RBstart=0
					67086	SCC1=1150 SCC2=5230	50 RB with RBstart=0	50 RB with RBstart=0	50 RB with RBstart=0	50 RB with RBstart=0
CA_66A-2A-48A ²	66	SCC1=2 SCC2=48	10	SCC1=10 SCC2=10	66486	SCC1=650 SCC2=55290	50 RB with RBstart=0	50 RB with RBstart=0	50 RB with RBstart=0	50 RB with RBstart=0
					66786	SCC1=900 SCC2=55990	50 RB with RBstart=0	50 RB with RBstart=0	50 RB with RBstart=0	50 RB with RBstart=0
					67086	SCC1=1150 SCC2=55290 ¹³	50 RB with RBstart=0	50 RB with RBstart=0	50 RB with RBstart=0	50 RB with RBstart=0
					67086	SCC1=1150 SCC2=56690	50 RB with RBstart=0	50 RB with RBstart=0	50 RB with RBstart=0	50 RB with RBstart=0
CA_66C-2A ^{5,7}	66	SCC1=66 SCC2=2	20	SCC1=20 SCC2=10	66536	SCC1=66734 ⁸ SCC2=650	100 RB with RBstart=0	100 RB with RBstart=0	100 RB with RBstart=0	50 RB with RBstart=0
					66786	SCC1=66984 ⁹ SCC2=900	100 RB with RBstart=0	100 RB with RBstart=0	100 RB with RBstart=0	50 RB with RBstart=0
					67036	SCC1=67234 SCC2=1150	100 RB with RBstart=0	100 RB with RBstart=0	100 RB with RBstart=0	50 RB with RBstart=0

TABLE 6-27 LTE CARRIER AGGREGATION MODE (3 DOWNLINK CARRIERS, 1 UPLINK CARRIER) TIS MEASUREMENTS
TABLE FOR THE PRIMARY MECHANICAL MODE¹

Carrier Aggregation Combination	Primary Component Carrier (PCC) Band	Secondary Component Carriers (SCC1/ SCC2) Bands	PCC BW (MHz)	SCC BWs (MHz)	PCC Channel	SCC Channels	PCC UL RB Allocation	PCC DL RB Allocation	SCC1 DL RB Allocation	SCC2 DL RB Allocation
CA_66A-2A-66A ⁵	66	SCC1=2 SCC2=66	10	SCC1=10 SCC2=10	66486	SCC1=650 SCC2=67286	50 RB with RBstart=0	50 RB with RBstart=0	50 RB with RBstart=0	50 RB with RBstart=0
					66486	SCC1=900 SCC2=67086 ⁶	50 RB with RBstart=0	50 RB with RBstart=0	50 RB with RBstart=0	50 RB with RBstart=0
					66786	SCC1=900 SCC2=66486	50 RB with RBstart=0	50 RB with RBstart=0	50 RB with RBstart=0	50 RB with RBstart=0
					67086	SCC1=1150 SCC2=66786	50 RB with RBstart=0	50 RB with RBstart=0	50 RB with RBstart=0	50 RB with RBstart=0
CA_66A-5A-5A ⁵	66	SCC1=5 SCC2=5	10	SCC1=5 SCC2=5	66486	SCC1=2425 SCC2=2525	50 RB with RBstart=0	50 RB with RBstart=0	25 RB with RBstart=0	25 RB with RBstart=0
					66786	SCC1=2525 SCC2=2625	50 RB with RBstart=0	50 RB with RBstart=0	25 RB with RBstart=0	25 RB with RBstart=0
					67086	SCC1=2625 SCC2=2425	50 RB with RBstart=0	50 RB with RBstart=0	25 RB with RBstart=0	25 RB with RBstart=0
CA_66A-5A-30A ⁵	66	SCC1=5 SCC2=30	10	SCC1=10 SCC2=10	66486	SCC1=2450 SCC2=9820	50 RB with RBstart=0	50 RB with RBstart=0	50 RB with RBstart=0	50 RB with RBstart=0
					66786	SCC1=2525 SCC2=9820	50 RB with RBstart=0	50 RB with RBstart=0	50 RB with RBstart=0	50 RB with RBstart=0
					67086	SCC1=2600 SCC2=9820	50 RB with RBstart=0	50 RB with RBstart=0	50 RB with RBstart=0	50 RB with RBstart=0
CA_66A-5A-48A ²	66	SCC1=5 SCC2=48	10	SCC1=10 SCC2=10	66486	SCC1=2450 SCC2=55290	50 RB with RBstart=0	50 RB with RBstart=0	50 RB with RBstart=0	50 RB with RBstart=0
					66786	SCC1=2525 SCC2=55990	50 RB with RBstart=0	50 RB with RBstart=0	50 RB with RBstart=0	50 RB with RBstart=0
					67086	SCC1=2525 SCC2=55290 ¹³	50 RB with RBstart=0	50 RB with RBstart=0	50 RB with RBstart=0	50 RB with RBstart=0
					67086	SCC1=2600 SCC2=56690	50 RB with RBstart=0	50 RB with RBstart=0	50 RB with RBstart=0	50 RB with RBstart=0
CA_66C-5A ^{5, 7}	66	SCC1=66 SCC2=5	20	SCC1=20 SCC2=10	66536	SCC1=66734 ⁸ SCC2=2450	100 RB with RBstart=0	100 RB with RBstart=0	100 RB with RBstart=0	50 RB with RBstart=0
					66786	SCC1=66984 ⁹ SCC2=2525	100 RB with RBstart=0	100 RB with RBstart=0	100 RB with RBstart=0	50 RB with RBstart=0
					67036	SCC1=67234 SCC2=2600	100 RB with RBstart=0	100 RB with RBstart=0	100 RB with RBstart=0	50 RB with RBstart=0

TABLE 6-27 LTE CARRIER AGGREGATION MODE (3 DOWNLINK CARRIERS, 1 UPLINK CARRIER) TIS MEASUREMENTS
TABLE FOR THE PRIMARY MECHANICAL MODE¹

Carrier Aggregation Combination	Primary Component Carrier (PCC) Band	Secondary Component Carriers (SCC1/ SCC2) Bands	PCC BW (MHz)	SCC BWs (MHz)	PCC Channel	SCC Channels	PCC UL RB Allocation	PCC DL RB Allocation	SCC1 DL RB Allocation	SCC2 DL RB Allocation
CA_66A-5A-66A ⁵	66	SCC1=5 SCC2=66	10	SCC1=10 SCC2=10	66486	SCC1=2450 SCC2=67286	50 RB with RBstart=0	50 RB with RBstart=0	50 RB with RBstart=0	50 RB with RBstart=0
					66486	SCC1=2525 SCC2=67086 ⁶	50 RB with RBstart=0	50 RB with RBstart=0	50 RB with RBstart=0	50 RB with RBstart=0
					66786	SCC1=2525 SCC2=66486	50 RB with RBstart=0	50 RB with RBstart=0	50 RB with RBstart=0	50 RB with RBstart=0
					67086	SCC1=2600 SCC2=66786	50 RB with RBstart=0	50 RB with RBstart=0	50 RB with RBstart=0	50 RB with RBstart=0
CA_66A-12A-29A ⁵	66	SCC1=12 SCC2=29	10	SCC1=5 SCC2=10	66486	SCC1=5035 SCC2=9720	50 RB with RBstart=0	50 RB with RBstart=0	25 RB with RBstart=0	50 RB with RBstart=0
					66786	SCC1=5095 SCC2=9720	50 RB with RBstart=0	50 RB with RBstart=0	25 RB with RBstart=0	50 RB with RBstart=0
					67086	SCC1=5155 SCC2=9720	50 RB with RBstart=0	50 RB with RBstart=0	25 RB with RBstart=0	50 RB with RBstart=0
CA_66A-12A-30A ⁵	66	SCC1=12 SCC2=30	10	SCC1=5 SCC2=10	66486	SCC1=5035 SCC2=9820	50 RB with RBstart=0	50 RB with RBstart=0	25 RB with RBstart=0	50 RB with RBstart=0
					66786	SCC1=5095 SCC2=9820	50 RB with RBstart=0	50 RB with RBstart=0	25 RB with RBstart=0	50 RB with RBstart=0
					67086	SCC1=5155 SCC2=9820	50 RB with RBstart=0	50 RB with RBstart=0	25 RB with RBstart=0	50 RB with RBstart=0
CA_66C-12A ^{5, 7}	66	SCC1=66 SCC2=12	20	SCC1=20 SCC2=5	66536	SCC1=66734 ⁸ SCC2=5035	100 RB with RBstart=0	100 RB with RBstart=0	100 RB with RBstart=0	25 RB with RBstart=0
					66786	SCC1=66984 ⁹ SCC2=5095	100 RB with RBstart=0	100 RB with RBstart=0	100 RB with RBstart=0	25 RB with RBstart=0
					67036	SCC1=67234 SCC2=5155	100 RB with RBstart=0	100 RB with RBstart=0	100 RB with RBstart=0	25 RB with RBstart=0
CA_66A-12A-66A ⁵	66	SCC1=12 SCC2=66	10	SCC1=5 SCC2=10	66486	SCC1=5035 SCC2=67286	50 RB with RBstart=0	50 RB with RBstart=0	25 RB with RBstart=0	50 RB with RBstart=0
					66486	SCC1=5095 SCC2=67086 ⁶	50 RB with RBstart=0	50 RB with RBstart=0	25 RB with RBstart=0	50 RB with RBstart=0
					66786	SCC1=5095 SCC2=66486	50 RB with RBstart=0	50 RB with RBstart=0	25 RB with RBstart=0	50 RB with RBstart=0
					67086	SCC1=5155 SCC2=66786	50 RB with RBstart=0	50 RB with RBstart=0	25 RB with RBstart=0	50 RB with RBstart=0

TABLE 6-27 LTE CARRIER AGGREGATION MODE (3 DOWNLINK CARRIERS, 1 UPLINK CARRIER) TIS MEASUREMENTS
TABLE FOR THE PRIMARY MECHANICAL MODE¹

Carrier Aggregation Combination	Primary Component Carrier (PCC) Band	Secondary Component Carriers (SCC1/ SCC2) Bands	PCC BW (MHz)	SCC BWs (MHz)	PCC Channel	SCC Channels	PCC UL RB Allocation	PCC DL RB Allocation	SCC1 DL RB Allocation	SCC2 DL RB Allocation
CA_66A-13A-48A ²	66	SCC1=13 SCC2=48	10	SCC1=10 SCC2=10	66486	SCC1=5230 SCC2=55290	50 RB with RBstart=0	50 RB with RBstart=0	50 RB with RBstart=0	50 RB with RBstart=0
					66786	SCC1=5230 SCC2=55990	50 RB with RBstart=0	50 RB with RBstart=0	50 RB with RBstart=0	50 RB with RBstart=0
					67086	SCC1=5230 SCC2=55290 ¹³	50 RB with RBstart=0	50 RB with RBstart=0	50 RB with RBstart=0	50 RB with RBstart=0
					67086	SCC1=5230 SCC2=56690	50 RB with RBstart=0	50 RB with RBstart=0	50 RB with RBstart=0	50 RB with RBstart=0
CA_66C-13A ^{5, 7}	66	SCC1=66 SCC2=13	20	SCC1=20 SCC2=10	66536	SCC1=66734 ⁸ SCC2=5230	100 RB with RBstart=0	100 RB with RBstart=0	100 RB with RBstart=0	50 RB with RBstart=0
					66786	SCC1=66984 ⁹ SCC2=5230	100 RB with RBstart=0	100 RB with RBstart=0	100 RB with RBstart=0	50 RB with RBstart=0
					67036	SCC1=67234 SCC2=5230	100 RB with RBstart=0	100 RB with RBstart=0	100 RB with RBstart=0	50 RB with RBstart=0
CA_66A-13A-66A ⁵	66	SCC1=13 SCC2=66	10	SCC1=10 SCC2=10	66486	SCC1=5230 SCC2=67286	50 RB with RBstart=0	50 RB with RBstart=0	50 RB with RBstart=0	50 RB with RBstart=0
					66486	SCC1=5230 SCC2=67086 ⁶	50 RB with RBstart=0	50 RB with RBstart=0	50 RB with RBstart=0	50 RB with RBstart=0
					66786	SCC1=5230 SCC2=66486	50 RB with RBstart=0	50 RB with RBstart=0	50 RB with RBstart=0	50 RB with RBstart=0
					67086	SCC1=5230 SCC2=66786	50 RB with RBstart=0	50 RB with RBstart=0	50 RB with RBstart=0	50 RB with RBstart=0
CA_66A-29A-30A ⁵	66	SCC1=29 SCC2=30	10	SCC1=10 SCC2=10	66486	SCC1=9720 SCC2=9820	50 RB with RBstart=0	50 RB with RBstart=0	50 RB with RBstart=0	50 RB with RBstart=0
					66786	SCC1=9720 SCC2=9820	50 RB with RBstart=0	50 RB with RBstart=0	50 RB with RBstart=0	50 RB with RBstart=0
					67086	SCC1=9720 SCC2=9820	50 RB with RBstart=0	50 RB with RBstart=0	50 RB with RBstart=0	50 RB with RBstart=0
CA_66C-29A ^{5, 7}	66	SCC1=66 SCC2=29	20	SCC1=20 SCC2=10	66536	SCC1=66734 ⁸ SCC2=9720	100 RB with RBstart=0	100 RB with RBstart=0	100 RB with RBstart=0	50 RB with RBstart=0
					66786	SCC1=66984 ⁹ SCC2=9720	100 RB with RBstart=0	100 RB with RBstart=0	100 RB with RBstart=0	50 RB with RBstart=0
					67036	SCC1=67234 SCC2=9720	100 RB with RBstart=0	100 RB with RBstart=0	100 RB with RBstart=0	50 RB with RBstart=0

TABLE 6-27 LTE CARRIER AGGREGATION MODE (3 DOWNLINK CARRIERS, 1 UPLINK CARRIER) TIS MEASUREMENTS
TABLE FOR THE PRIMARY MECHANICAL MODE¹

Carrier Aggregation Combination	Primary Component Carrier (PCC) Band	Secondary Component Carriers (SCC1/ SCC2) Bands	PCC BW (MHz)	SCC BWs (MHz)	PCC Channel	SCC Channels	PCC UL RB Allocation	PCC DL RB Allocation	SCC1 DL RB Allocation	SCC2 DL RB Allocation
CA_66A-29A-66A ⁵	66	SCC1=29 SCC2=66	10	SCC1=10 SCC2=10	66486	SCC1=9720 SCC2=67286	50 RB with RBstart=0	50 RB with RBstart=0	50 RB with RBstart=0	50 RB with RBstart=0
					66486	SCC1=9720 SCC2=67086 ⁶	50 RB with RBstart=0	50 RB with RBstart=0	50 RB with RBstart=0	50 RB with RBstart=0
					66786	SCC1=9720 SCC2=66486	50 RB with RBstart=0	50 RB with RBstart=0	50 RB with RBstart=0	50 RB with RBstart=0
					67086	SCC1=9720 SCC2=66786	50 RB with RBstart=0	50 RB with RBstart=0	50 RB with RBstart=0	50 RB with RBstart=0
CA_66C-30A ^{5, 7}	66	SCC1=66 SCC2=30	20	SCC1=20 SCC2=10	66536	SCC1=66734 ⁸ SCC2=9820	100 RB with RBstart=0	100 RB with RBstart=0	100 RB with RBstart=0	50 RB with RBstart=0
					66786	SCC1=66984 ⁹ SCC2=9820	100 RB with RBstart=0	100 RB with RBstart=0	100 RB with RBstart=0	50 RB with RBstart=0
					67036	SCC1=67234 SCC2=9820	100 RB with RBstart=0	100 RB with RBstart=0	100 RB with RBstart=0	50 RB with RBstart=0
CA_66A-30A-66A ⁵	66	SCC1=30 SCC2=66	10	SCC1=10 SCC2=10	66486	SCC1=9820 SCC2=67286	50 RB with RBstart=0	50 RB with RBstart=0	50 RB with RBstart=0	50 RB with RBstart=0
					66486	SCC1=9820 SCC2=67086 ⁶	50 RB with RBstart=0	50 RB with RBstart=0	50 RB with RBstart=0	50 RB with RBstart=0
					66786	SCC1=9820 SCC2=66486	50 RB with RBstart=0	50 RB with RBstart=0	50 RB with RBstart=0	50 RB with RBstart=0
					67086	SCC1=9820 SCC2=66786	50 RB with RBstart=0	50 RB with RBstart=0	50 RB with RBstart=0	50 RB with RBstart=0
CA_66D	66	SCC1=66 SCC2=66	20	SCC1=20 SCC2=20	66536	SCC1=66734 SCC2=66932 ⁹	100 RB with RBstart=0	100 RB with RBstart=0	100 RB with RBstart=0	100 RB with RBstart=0
					67036	SCC1=66838 ¹² SCC2=67234	100 RB with RBstart=0	100 RB with RBstart=0	100 RB with RBstart=0	100 RB with RBstart=0

TABLE 6-27 LTE CARRIER AGGREGATION MODE (3 DOWNLINK CARRIERS, 1 UPLINK CARRIER) TIS MEASUREMENTS
TABLE FOR THE PRIMARY MECHANICAL MODE¹

Carrier Aggregation Combination	Primary Component Carrier (PCC) Band	Secondary Component Carriers (SCC1/ SCC2) Bands	PCC BW (MHz)	SCC BWs (MHz)	PCC Channel	SCC Channels	PCC UL RB Allocation	PCC DL RB Allocation	SCC1 DL RB Allocation	SCC2 DL RB Allocation
CA_66C-66A ⁷	66	SCC1=66 SCC2=66	20	SCC1=20 SCC2=10	67036	SCC1=67234 SCC2=66486	100 RB with RBstart=0	100 RB with RBstart=0	100 RB with RBstart=0	50 RB with RBstart=0
CA_66A-66C ⁷	66	SCC1=66 SCC2=66	10	SCC1=20 SCC2=20	66486	SCC1=67036 SCC2=67234	50 RB with RBstart=0	50 RB with RBstart=0	100 RB with RBstart=0	100 RB with RBstart=0

Note 1: Primary Mechanical Mode refers to device configured in preferred mode per manufacturer instructions (typically means antenna extended, fold or portrait slide open, but depends on form factor).

Note 2: This combination creates harmonic, intermodulation, or self-desense interference to one or both of the SCC's. The power level of the SCC's shall be adjusted as needed to maintain the LTE carrier aggregation connection and error free operation on the SCC's.

Note 3: An additional set of channel conditions was added for CA_2A-2A-x to address the case where Wgap is ≤ 10 (per Table 7.3.1A-3 of 3GPP TS 36.101).

Note 4: TIS testing is not required for the PCC on channel 800, nor the SCC2 when the PCC is on channel 800. TIS testing is only required for the SCC1 on channel 650.

Note 5: If the device supports both CA_4A-xA-yA and CA_66A-xA-yA (where x and y are the band numbers of the SCC's), then testing is only required in CA_66A-xA-yA. Similarly, if the device supports both CA_xA-4A-yA/CA_xA-yA-4A and CA_xA-66A-yA/CA_xA-yA-66A (where x is the band number of the PCC and y is the band number of the other SCC), then testing is only required in CA_xA-66A-yA/CA_xA-yA-66A.

Note 6: Except for CA_2A-2A-66A and CA_5A-5A-66A, when there is a Band 66 SCC on channel 67086, TIS testing is only required on the Band 66 SCC on channel 67086 (TIS testing is not required on the PCC or the other SCC). For CA_2A-2A-66A and CA_5A-5A-66A, TIS testing is required for the PCC and both SCC's.

Note 7: Since all Band 66-capable devices are required to support both CA_66B and CA_66C per 3GPP TS 36.101, testing of xA-66B and 66B-xA combinations is not required.

Note 8: TIS testing on this SCC is not required when the antenna configuration remains the same when the PCC changes to the mid channel.

Note 9: TIS testing on this SCC is not required when the antenna configuration remains the same when the PCC changes to the high channel.

Note 10: An additional set of channel conditions was added for CA_5A-5A-x to address the case where receiver sensitivity relaxation is allowed per Table 7.3.1A-3 of 3GPP TS 36.101.

Note 11: TIS testing is not required for the PCC on channel 2425 when the SCC1 is on channel 2625. TIS testing is only required for the SCC1 on channel 2625 and the SCC2 on channel 67286.

Note 12: TIS testing on this SCC is not required when the antenna configuration remains the same when the PCC changes to the low channel.

Note 13: TIS testing is not required on the PCC and SCC1. TIS testing is only required on the Band 48 SCC2 on channel 55290.

Hand phantom only and/or free-space testing shall be conducted based on device type, as specified in [Appendix O](#). Refer to [Appendix C](#) for hand testing requirements. Perform each test on all supported CA modes defined in according to the use cases associated with each band as specified in [Table 6-27](#) with the EUT antenna extended and retracted, as applicable.

Note: Head-adjacent testing is not required for LTE CA.

Note: EUTs incapable of supporting the aggregated channel BW associated with the CA modes specified in do not need to be tested.

6.17.2 Criteria

Results shall be reported as specified in [Appendix B](#) using the figures of merit given in [Appendix B.3](#). [Appendix B.1](#) contains the pass/fail OTA tables for 3 downlink LTE carrier aggregation. Reports shall include results for free-space and hand only configurations (if applicable) across all applicable channels

defined in Table 6-27. When applicable, the receiver performance in all CA band combinations shall be measured once with the EUT antenna extended and again with it retracted.

C-TIS shall meet the limits for the PCC, SCC1, and SCC2 as shown in Table 6-28 below.

TABLE 6-28 LTE MAXIMUM C-TIS LEVEL REQUIREMENTS FOR PCC, SCC1, AND SCC2 IN CARRIER AGGREGATION MODE (3 DOWNLINK CARRIERS, 1 UPLINK CARRIER) FOR THE PRIMARY MECHANICAL MODE¹

Carrier Aggregation Combination	PCC / SCC	Device Held Up to Head for Voice (Yes/No)	Device Width (mm) ²	Free Space	HL and HR
CA_2A-2A-4A ³	PCC	Yes ⁴	≤72	TBD	TBD
			>72	TBD	TBD
	SCC1	No ⁵	All	TBD	N/A
		Yes ⁴	≤72	TBD	TBD
	SCC2		>72	TBD	TBD
		No ⁵	All	TBD	N/A
CA_2A-2A-5A ³	PCC	Yes ⁴	≤72	TBD	TBD
			>72	TBD	TBD
	SCC1	No ⁵	All	TBD	N/A
		Yes ⁴	≤72	TBD	TBD
	SCC2		>72	TBD	TBD
		No ⁵	All	TBD	N/A
CA_2A-2A-12A ³	PCC	Yes ⁴	≤72	TBD	TBD
			>72	TBD	TBD
	SCC1	No ⁵	All	TBD	N/A
		Yes ⁴	≤72	TBD	TBD
	SCC2		>72	TBD	TBD
		No ⁵	All	TBD	N/A

TABLE 6-28 LTE MAXIMUM C-TIS LEVEL REQUIREMENTS FOR PCC, SCC1, AND SCC2 IN CARRIER AGGREGATION MODE (3 DOWNLINK CARRIERS, 1 UPLINK CARRIER) FOR THE PRIMARY MECHANICAL MODE¹

Carrier Aggregation Combination	PCC / SCC	Device Held Up to Head for Voice (Yes/No)	Device Width (mm) ²	Free Space	HL and HR
CA_2A-2A-13A ³	PCC	Yes ⁴	≤72	TBD	TBD
			>72	TBD	TBD
	SCC1	No ⁵	All	TBD	N/A
		Yes ⁴	≤72	TBD	TBD
	SCC2		>72	TBD	TBD
		No ⁵	All	TBD	N/A
CA_2A-2A-66A ³	PCC	Yes ⁴	≤72	TBD	TBD
			>72	TBD	TBD
	SCC1	No ⁵	All	TBD	N/A
		Yes ⁴	≤72	TBD	TBD
	SCC2		>72	TBD	TBD
		No ⁵	All	TBD	N/A
CA_2A-4A-4A	PCC	Yes ⁴	≤72	TBD	TBD
			>72	TBD	TBD
	SCC1	No ⁵	All	TBD	N/A
		Yes ⁴	≤72	TBD	TBD
	SCC2		>72	TBD	TBD
		No ⁵	All	TBD	N/A

TABLE 6-28 LTE MAXIMUM C-TIS LEVEL REQUIREMENTS FOR PCC, SCC1, AND SCC2 IN CARRIER AGGREGATION MODE (3 DOWNLINK CARRIERS, 1 UPLINK CARRIER) FOR THE PRIMARY MECHANICAL MODE¹

Carrier Aggregation Combination	PCC / SCC	Device Held Up to Head for Voice (Yes/No)	Device Width (mm) ²	Free Space	HL and HR
CA_2A-4A-5A	PCC	Yes ⁴	≤72	TBD	TBD
			>72	TBD	TBD
	No ⁵	All	TBD	N/A	
	SCC1	Yes ⁴	≤72	TBD	TBD
			>72	TBD	TBD
No ⁵	All	TBD	N/A		
SCC2	Yes ⁴	≤72	TBD	TBD	
		>72	TBD	TBD	
No ⁵	All	TBD	N/A		
CA_2A-4A-12A	PCC	Yes ⁴	≤72	TBD	TBD
			>72	TBD	TBD
	No ⁵	All	TBD	N/A	
	SCC1	Yes ⁴	≤72	TBD	TBD
			>72	TBD	TBD
No ⁵	All	TBD	N/A		
SCC2	Yes ⁴	≤72	TBD	TBD	
		>72	TBD	TBD	
No ⁵	All	TBD	N/A		
CA_2A-4A-13A	PCC	Yes ⁴	≤72	TBD	TBD
			>72	TBD	TBD
	No ⁵	All	TBD	N/A	
	SCC1	Yes ⁴	≤72	TBD	TBD
			>72	TBD	TBD
No ⁵	All	TBD	N/A		
SCC2	Yes ⁴	≤72	TBD	TBD	
		>72	TBD	TBD	
No ⁵	All	TBD	N/A		

TABLE 6-28 LTE MAXIMUM C-TIS LEVEL REQUIREMENTS FOR PCC, SCC1, AND SCC2 IN CARRIER AGGREGATION MODE (3 DOWNLINK CARRIERS, 1 UPLINK CARRIER) FOR THE PRIMARY MECHANICAL MODE¹

Carrier Aggregation Combination	PCC / SCC	Device Held Up to Head for Voice (Yes/No)	Device Width (mm) ²	Free Space	HL and HR
CA_2A-5A-30A	PCC	Yes ⁴	≤72	TBD	TBD
			>72	TBD	TBD
		No ⁵	All	TBD	N/A
	SCC1	Yes ⁴	≤72	TBD	TBD
			>72	TBD	TBD
	No ⁵	All	TBD	N/A	
SCC2	Yes ⁴	≤72	TBD	TBD	
		>72	TBD	TBD	
	No ⁵	All	TBD	N/A	
CA_2A-5A-48A	PCC	Yes ⁴	≤72	TBD	TBD
			>72	TBD	TBD
		No ⁵	All	TBD	N/A
	SCC1	Yes ⁴	≤72	TBD	TBD
			>72	TBD	TBD
	No ⁵	All	TBD	N/A	
SCC2	Yes ⁴	≤72	TBD	TBD	
		>72	TBD	TBD	
	No ⁵	All	TBD	N/A	
CA_2A-5A-66A	PCC	Yes ⁴	≤72	TBD	TBD
			>72	TBD	TBD
		No ⁵	All	TBD	N/A
	SCC1	Yes ⁴	≤72	TBD	TBD
			>72	TBD	TBD
	No ⁵	All	TBD	N/A	
SCC2	Yes ⁴	≤72	TBD	TBD	
		>72	TBD	TBD	
	No ⁵	All	TBD	N/A	

TABLE 6-28 LTE MAXIMUM C-TIS LEVEL REQUIREMENTS FOR PCC, SCC1, AND SCC2 IN CARRIER AGGREGATION MODE (3 DOWNLINK CARRIERS, 1 UPLINK CARRIER) FOR THE PRIMARY MECHANICAL MODE¹

Carrier Aggregation Combination	PCC / SCC	Device Held Up to Head for Voice (Yes/No)	Device Width (mm) ²	Free Space	HL and HR
CA_2A-12A-30A	PCC	Yes ⁴	≤72	TBD	TBD
			>72	TBD	TBD
	No ⁵	All	TBD	N/A	
	SCC1	Yes ⁴	≤72	TBD	TBD
			>72	TBD	TBD
No ⁵	All	TBD	N/A		
SCC2	Yes ⁴	≤72	TBD	TBD	
		>72	TBD	TBD	
No ⁵	All	TBD	N/A		
CA_2A-12A-66A	PCC	Yes ⁴	≤72	TBD	TBD
			>72	TBD	TBD
	No ⁵	All	TBD	N/A	
	SCC1	Yes ⁴	≤72	TBD	TBD
			>72	TBD	TBD
No ⁵	All	TBD	N/A		
SCC2	Yes ⁴	≤72	TBD	TBD	
		>72	TBD	TBD	
No ⁵	All	TBD	N/A		
CA_2A-13A-48A	PCC	Yes ⁴	≤72	TBD	TBD
			>72	TBD	TBD
	No ⁵	All	TBD	N/A	
	SCC1	Yes ⁴	≤72	TBD	TBD
			>72	TBD	TBD
No ⁵	All	TBD	N/A		
SCC2	Yes ⁴	≤72	TBD	TBD	
		>72	TBD	TBD	
No ⁵	All	TBD	N/A		

TABLE 6-28 LTE MAXIMUM C-TIS LEVEL REQUIREMENTS FOR PCC, SCC1, AND SCC2 IN CARRIER AGGREGATION MODE (3 DOWNLINK CARRIERS, 1 UPLINK CARRIER) FOR THE PRIMARY MECHANICAL MODE¹

Carrier Aggregation Combination	PCC / SCC	Device Held Up to Head for Voice (Yes/No)	Device Width (mm) ²	Free Space	HL and HR
CA_2A-13A-66A	PCC	Yes ⁴	≤72	TBD	TBD
			>72	TBD	TBD
		No ⁵	All	TBD	N/A
	SCC1	Yes ⁴	≤72	TBD	TBD
			>72	TBD	TBD
	No ⁵	All	TBD	N/A	
SCC2	Yes ⁴	≤72	TBD	TBD	
		>72	TBD	TBD	
	No ⁵	All	TBD	N/A	
CA_2A-29A-30A	PCC	Yes ⁴	≤72	TBD	TBD
			>72	TBD	TBD
		No ⁵	All	TBD	N/A
	SCC1	Yes ⁴	≤72	TBD	TBD
			>72	TBD	TBD
	No ⁵	All	TBD	N/A	
SCC2	Yes ⁴	≤72	TBD	TBD	
		>72	TBD	TBD	
	No ⁵	All	TBD	N/A	
CA_2A-48A-66A	PCC	Yes ⁴	≤72	TBD	TBD
			>72	TBD	TBD
		No ⁵	All	TBD	N/A
	SCC1	Yes ⁴	≤72	TBD	TBD
			>72	TBD	TBD
	No ⁵	All	TBD	N/A	
SCC2	Yes ⁴	≤72	TBD	TBD	
		>72	TBD	TBD	
	No ⁵	All	TBD	N/A	

TABLE 6-28 LTE MAXIMUM C-TIS LEVEL REQUIREMENTS FOR PCC, SCC1, AND SCC2 IN CARRIER AGGREGATION MODE (3 DOWNLINK CARRIERS, 1 UPLINK CARRIER) FOR THE PRIMARY MECHANICAL MODE¹

Carrier Aggregation Combination	PCC / SCC	Device Held Up to Head for Voice (Yes/No)	Device Width (mm) ²	Free Space	HL and HR
CA_2A-66C	PCC	Yes ⁴	≤72	TBD	TBD
			>72	TBD	TBD
	No ⁵	All	TBD	N/A	
	SCC1	Yes ⁴	≤72	TBD	TBD
			>72	TBD	TBD
No ⁵	All	TBD	N/A		
SCC2	Yes ⁴	≤72	TBD	TBD	
		>72	TBD	TBD	
No ⁵	All	TBD	N/A		
CA_2A-66A-66A	PCC	Yes ⁴	≤72	TBD	TBD
			>72	TBD	TBD
	No ⁵	All	TBD	N/A	
	SCC1	Yes ⁴	≤72	TBD	TBD
			>72	TBD	TBD
No ⁵	All	TBD	N/A		
SCC2	Yes ⁴	≤72	TBD	TBD	
		>72	TBD	TBD	
No ⁵	All	TBD	N/A		
CA_4A-2A-4A	PCC	Yes ⁴	≤72	TBD	TBD
			>72	TBD	TBD
	No ⁵	All	TBD	N/A	
	SCC1	Yes ⁴	≤72	TBD	TBD
			>72	TBD	TBD
No ⁵	All	TBD	N/A		
SCC2	Yes ⁴	≤72	TBD	TBD	
		>72	TBD	TBD	
No ⁵	All	TBD	N/A		

TABLE 6-28 LTE MAXIMUM C-TIS LEVEL REQUIREMENTS FOR PCC, SCC1, AND SCC2 IN CARRIER AGGREGATION MODE (3 DOWNLINK CARRIERS, 1 UPLINK CARRIER) FOR THE PRIMARY MECHANICAL MODE¹

Carrier Aggregation Combination	PCC / SCC	Device Held Up to Head for Voice (Yes/No)	Device Width (mm) ²	Free Space	HL and HR
CA_4A-2A-5A	PCC	Yes ⁴	≤72	TBD	TBD
			>72	TBD	TBD
	No ⁵	All	TBD	N/A	
	SCC1	Yes ⁴	≤72	TBD	TBD
			>72	TBD	TBD
No ⁵	All	TBD	N/A		
SCC2	Yes ⁴	≤72	TBD	TBD	
		>72	TBD	TBD	
No ⁵	All	TBD	N/A		
CA_4A-2A-12A	PCC	Yes ⁴	≤72	TBD	TBD
			>72	TBD	TBD
	No ⁵	All	TBD	N/A	
	SCC1	Yes ⁴	≤72	TBD	TBD
			>72	TBD	TBD
No ⁵	All	TBD	N/A		
SCC2	Yes ⁴	≤72	TBD	TBD	
		>72	TBD	TBD	
No ⁵	All	TBD	N/A		
CA_4A-2A-13A	PCC	Yes ⁴	≤72	TBD	TBD
			>72	TBD	TBD
	No ⁵	All	TBD	N/A	
	SCC1	Yes ⁴	≤72	TBD	TBD
			>72	TBD	TBD
No ⁵	All	TBD	N/A		
SCC2	Yes ⁴	≤72	TBD	TBD	
		>72	TBD	TBD	
No ⁵	All	TBD	N/A		

TABLE 6-28 LTE MAXIMUM C-TIS LEVEL REQUIREMENTS FOR PCC, SCC1, AND SCC2 IN CARRIER AGGREGATION MODE (3 DOWNLINK CARRIERS, 1 UPLINK CARRIER) FOR THE PRIMARY MECHANICAL MODE¹

Carrier Aggregation Combination	PCC / SCC	Device Held Up to Head for Voice (Yes/No)	Device Width (mm) ²	Free Space	HL and HR
CA_4A-4A-5A	PCC	Yes ⁴	≤72	TBD	TBD
			>72	TBD	TBD
		No ⁵	All	TBD	N/A
	SCC1	Yes ⁴	≤72	TBD	TBD
			>72	TBD	TBD
	No ⁵	All	TBD	N/A	
SCC2	Yes ⁴	≤72	TBD	TBD	
		>72	TBD	TBD	
	No ⁵	All	TBD	N/A	
CA_4A-4A-12A	PCC	Yes ⁴	≤72	TBD	TBD
			>72	TBD	TBD
		No ⁵	All	TBD	N/A
	SCC1	Yes ⁴	≤72	TBD	TBD
			>72	TBD	TBD
	No ⁵	All	TBD	N/A	
SCC2	Yes ⁴	≤72	TBD	TBD	
		>72	TBD	TBD	
	No ⁵	All	TBD	N/A	
CA_4A-4A-13A	PCC	Yes ⁴	≤72	TBD	TBD
			>72	TBD	TBD
		No ⁵	All	TBD	N/A
	SCC1	Yes ⁴	≤72	TBD	TBD
			>72	TBD	TBD
	No ⁵	All	TBD	N/A	
SCC2	Yes ⁴	≤72	TBD	TBD	
		>72	TBD	TBD	
	No ⁵	All	TBD	N/A	

TABLE 6-28 LTE MAXIMUM C-TIS LEVEL REQUIREMENTS FOR PCC, SCC1, AND SCC2 IN CARRIER AGGREGATION MODE (3 DOWNLINK CARRIERS, 1 UPLINK CARRIER) FOR THE PRIMARY MECHANICAL MODE¹

Carrier Aggregation Combination	PCC / SCC	Device Held Up to Head for Voice (Yes/No)	Device Width (mm) ²	Free Space	HL and HR
CA_4A-5A-30A	PCC	Yes ⁴	≤72	TBD	TBD
			>72	TBD	TBD
		No ⁵	All	TBD	N/A
	SCC1	Yes ⁴	≤72	TBD	TBD
			>72	TBD	TBD
	No ⁵	All	TBD	N/A	
SCC2	Yes ⁴	≤72	TBD	TBD	
		>72	TBD	TBD	
	No ⁵	All	TBD	N/A	
CA_4A-12A-30A	PCC	Yes ⁴	≤72	TBD	TBD
			>72	TBD	TBD
		No ⁵	All	TBD	N/A
	SCC1	Yes ⁴	≤72	TBD	TBD
			>72	TBD	TBD
	No ⁵	All	TBD	N/A	
SCC2	Yes ⁴	≤72	TBD	TBD	
		>72	TBD	TBD	
	No ⁵	All	TBD	N/A	
CA_4A-29A-30A	PCC	Yes ⁴	≤72	TBD	TBD
			>72	TBD	TBD
		No ⁵	All	TBD	N/A
	SCC1	Yes ⁴	≤72	TBD	TBD
			>72	TBD	TBD
	No ⁵	All	TBD	N/A	
SCC2	Yes ⁴	≤72	TBD	TBD	
		>72	TBD	TBD	
	No ⁵	All	TBD	N/A	

TABLE 6-28 LTE MAXIMUM C-TIS LEVEL REQUIREMENTS FOR PCC, SCC1, AND SCC2 IN CARRIER AGGREGATION MODE (3 DOWNLINK CARRIERS, 1 UPLINK CARRIER) FOR THE PRIMARY MECHANICAL MODE¹

Carrier Aggregation Combination	PCC / SCC	Device Held Up to Head for Voice (Yes/No)	Device Width (mm) ²	Free Space	HL and HR
CA_5A-2A-2A	PCC	Yes ⁴	≤72	TBD	TBD
			>72	TBD	TBD
		No ⁵	All	TBD	N/A
	SCC1	Yes ⁴	≤72	TBD	TBD
			>72	TBD	TBD
	No ⁵	All	TBD	N/A	
SCC2	Yes ⁴	≤72	TBD	TBD	
		>72	TBD	TBD	
	No ⁵	All	TBD	N/A	
CA_5A-2A-4A	PCC	Yes ⁴	≤72	TBD	TBD
			>72	TBD	TBD
		No ⁵	All	TBD	N/A
	SCC1	Yes ⁴	≤72	TBD	TBD
			>72	TBD	TBD
	No ⁵	All	TBD	N/A	
SCC2	Yes ⁴	≤72	TBD	TBD	
		>72	TBD	TBD	
	No ⁵	All	TBD	N/A	
CA_5A-2A-30A	PCC	Yes ⁴	≤72	TBD	TBD
			>72	TBD	TBD
		No ⁵	All	TBD	N/A
	SCC1	Yes ⁴	≤72	TBD	TBD
			>72	TBD	TBD
	No ⁵	All	TBD	N/A	
SCC2	Yes ⁴	≤72	TBD	TBD	
		>72	TBD	TBD	
	No ⁵	All	TBD	N/A	

TABLE 6-28 LTE MAXIMUM C-TIS LEVEL REQUIREMENTS FOR PCC, SCC1, AND SCC2 IN CARRIER AGGREGATION MODE (3 DOWNLINK CARRIERS, 1 UPLINK CARRIER) FOR THE PRIMARY MECHANICAL MODE¹

Carrier Aggregation Combination	PCC / SCC	Device Held Up to Head for Voice (Yes/No)	Device Width (mm) ²	Free Space	HL and HR
CA_5A-2A-48A	PCC	Yes ⁴	≤72	TBD	TBD
			>72	TBD	TBD
	No ⁵	All	TBD	N/A	
	SCC1	Yes ⁴	≤72	TBD	TBD
			>72	TBD	TBD
No ⁵	All	TBD	N/A		
SCC2	Yes ⁴	≤72	TBD	TBD	
		>72	TBD	TBD	
No ⁵	All	TBD	N/A		
CA_5A-2A-66A	PCC	Yes ⁴	≤72	TBD	TBD
			>72	TBD	TBD
	No ⁵	All	TBD	N/A	
	SCC1	Yes ⁴	≤72	TBD	TBD
			>72	TBD	TBD
No ⁵	All	TBD	N/A		
SCC2	Yes ⁴	≤72	TBD	TBD	
		>72	TBD	TBD	
No ⁵	All	TBD	N/A		
CA_5A-4A-4A	PCC	Yes ⁴	≤72	TBD	TBD
			>72	TBD	TBD
	No ⁵	All	TBD	N/A	
	SCC1	Yes ⁴	≤72	TBD	TBD
			>72	TBD	TBD
No ⁵	All	TBD	N/A		
SCC2	Yes ⁴	≤72	TBD	TBD	
		>72	TBD	TBD	
No ⁵	All	TBD	N/A		

TABLE 6-28 LTE MAXIMUM C-TIS LEVEL REQUIREMENTS FOR PCC, SCC1, AND SCC2 IN CARRIER AGGREGATION MODE (3 DOWNLINK CARRIERS, 1 UPLINK CARRIER) FOR THE PRIMARY MECHANICAL MODE¹

Carrier Aggregation Combination	PCC / SCC	Device Held Up to Head for Voice (Yes/No)	Device Width (mm) ²	Free Space	HL and HR
CA_5A-4A-30A	PCC	Yes ⁴	≤72	TBD	TBD
			>72	TBD	TBD
	No ⁵	All	TBD	N/A	
	SCC1	Yes ⁴	≤72	TBD	TBD
			>72	TBD	TBD
No ⁵	All	TBD	N/A		
SCC2	Yes ⁴	≤72	TBD	TBD	
		>72	TBD	TBD	
No ⁵	All	TBD	N/A		
CA_5A-5A-66A	PCC	Yes ⁴	≤72	TBD	TBD
			>72	TBD	TBD
	No ⁵	All	TBD	N/A	
	SCC1	Yes ⁴	≤72	TBD	TBD
			>72	TBD	TBD
No ⁵	All	TBD	N/A		
SCC2	Yes ⁴	≤72	TBD	TBD	
		>72	TBD	TBD	
No ⁵	All	TBD	N/A		
CA_5A-29A-30A	PCC	Yes ⁴	≤72	TBD	TBD
			>72	TBD	TBD
	No ⁵	All	TBD	N/A	
	SCC1	Yes ⁴	≤72	TBD	TBD
			>72	TBD	TBD
No ⁵	All	TBD	N/A		
SCC2	Yes ⁴	≤72	TBD	TBD	
		>72	TBD	TBD	
No ⁵	All	TBD	N/A		

TABLE 6-28 LTE MAXIMUM C-TIS LEVEL REQUIREMENTS FOR PCC, SCC1, AND SCC2 IN CARRIER AGGREGATION MODE (3 DOWNLINK CARRIERS, 1 UPLINK CARRIER) FOR THE PRIMARY MECHANICAL MODE¹

Carrier Aggregation Combination	PCC / SCC	Device Held Up to Head for Voice (Yes/No)	Device Width (mm) ²	Free Space	HL and HR
CA_5A-30A-66A	PCC	Yes ⁴	≤72	TBD	TBD
			>72	TBD	TBD
	No ⁵	All	TBD	N/A	
	SCC1	Yes ⁴	≤72	TBD	TBD
			>72	TBD	TBD
No ⁵	All	TBD	N/A		
SCC2	Yes ⁴	≤72	TBD	TBD	
		>72	TBD	TBD	
No ⁵	All	TBD	N/A		
CA_5A-48A-66A	PCC	Yes ⁴	≤72	TBD	TBD
			>72	TBD	TBD
	No ⁵	All	TBD	N/A	
	SCC1	Yes ⁴	≤72	TBD	TBD
			>72	TBD	TBD
No ⁵	All	TBD	N/A		
SCC2	Yes ⁴	≤72	TBD	TBD	
		>72	TBD	TBD	
No ⁵	All	TBD	N/A		
CA_5A-66C	PCC	Yes ⁴	≤72	TBD	TBD
			>72	TBD	TBD
	No ⁵	All	TBD	N/A	
	SCC1	Yes ⁴	≤72	TBD	TBD
			>72	TBD	TBD
No ⁵	All	TBD	N/A		
SCC2	Yes ⁴	≤72	TBD	TBD	
		>72	TBD	TBD	
No ⁵	All	TBD	N/A		

TABLE 6-28 LTE MAXIMUM C-TIS LEVEL REQUIREMENTS FOR PCC, SCC1, AND SCC2 IN CARRIER AGGREGATION MODE (3 DOWNLINK CARRIERS, 1 UPLINK CARRIER) FOR THE PRIMARY MECHANICAL MODE¹

Carrier Aggregation Combination	PCC / SCC	Device Held Up to Head for Voice (Yes/No)	Device Width (mm) ²	Free Space	HL and HR
CA_5A-66A-66A	PCC	Yes ⁴	≤72	TBD	TBD
			>72	TBD	TBD
	No ⁵	All	TBD	N/A	
	SCC1	Yes ⁴	≤72	TBD	TBD
			>72	TBD	TBD
No ⁵	All	TBD	N/A		
SCC2	Yes ⁴	≤72	TBD	TBD	
		>72	TBD	TBD	
No ⁵	All	TBD	N/A		
CA_12A-2A-2A	PCC	Yes ⁴	≤72	TBD	TBD
			>72	TBD	TBD
	No ⁵	All	TBD	N/A	
	SCC1	Yes ⁴	≤72	TBD	TBD
			>72	TBD	TBD
No ⁵	All	TBD	N/A		
SCC2	Yes ⁴	≤72	TBD	TBD	
		>72	TBD	TBD	
No ⁵	All	TBD	N/A		
CA_12A-2A-4A ³	PCC	Yes ⁴	≤72	TBD	TBD
			>72	TBD	TBD
	No ⁵	All	TBD	N/A	
	SCC1	Yes ⁴	≤72	TBD	TBD
			>72	TBD	TBD
No ⁵	All	TBD	N/A		
SCC2	Yes ⁴	≤72	TBD	TBD	
		>72	TBD	TBD	
No ⁵	All	TBD	N/A		

TABLE 6-28 LTE MAXIMUM C-TIS LEVEL REQUIREMENTS FOR PCC, SCC1, AND SCC2 IN CARRIER AGGREGATION MODE (3 DOWNLINK CARRIERS, 1 UPLINK CARRIER) FOR THE PRIMARY MECHANICAL MODE¹

Carrier Aggregation Combination	PCC / SCC	Device Held Up to Head for Voice (Yes/No)	Device Width (mm) ²	Free Space	HL and HR
CA_12A-2A-30A	PCC	Yes ⁴	≤72	TBD	TBD
			>72	TBD	TBD
		No ⁵	All	TBD	N/A
	SCC1	Yes ⁴	≤72	TBD	TBD
			>72	TBD	TBD
	No ⁵	All	TBD	N/A	
SCC2	Yes ⁴	≤72	TBD	TBD	
		>72	TBD	TBD	
	No ⁵	All	TBD	N/A	
CA_12A-2A-66A	PCC	Yes ⁴	≤72	TBD	TBD
			>72	TBD	TBD
		No ⁵	All	TBD	N/A
	SCC1	Yes ⁴	≤72	TBD	TBD
			>72	TBD	TBD
	No ⁵	All	TBD	N/A	
SCC2	Yes ⁴	≤72	TBD	TBD	
		>72	TBD	TBD	
	No ⁵	All	TBD	N/A	
CA_12A-4A-4A ³	PCC	Yes ⁴	≤72	TBD	TBD
			>72	TBD	TBD
		No ⁵	All	TBD	N/A
	SCC1	Yes ⁴	≤72	TBD	TBD
			>72	TBD	TBD
	No ⁵	All	TBD	N/A	
SCC2	Yes ⁴	≤72	TBD	TBD	
		>72	TBD	TBD	
	No ⁵	All	TBD	N/A	

TABLE 6-28 LTE MAXIMUM C-TIS LEVEL REQUIREMENTS FOR PCC, SCC1, AND SCC2 IN CARRIER AGGREGATION MODE (3 DOWNLINK CARRIERS, 1 UPLINK CARRIER) FOR THE PRIMARY MECHANICAL MODE¹

Carrier Aggregation Combination	PCC / SCC	Device Held Up to Head for Voice (Yes/No)	Device Width (mm) ²	Free Space	HL and HR
CA_12A-4A-30A ³	PCC	Yes ⁴	≤72	TBD	TBD
			>72	TBD	TBD
		No ⁵	All	TBD	N/A
	SCC1	Yes ⁴	≤72	TBD	TBD
			>72	TBD	TBD
	No ⁵	All	TBD	N/A	
SCC2	Yes ⁴	≤72	TBD	TBD	
		>72	TBD	TBD	
	No ⁵	All	TBD	N/A	
CA_12A-29A-66A	PCC	Yes ⁴	≤72	TBD	TBD
			>72	TBD	TBD
		No ⁵	All	TBD	N/A
	SCC1	Yes ⁴	≤72	TBD	TBD
			>72	TBD	TBD
	No ⁵	All	TBD	N/A	
SCC2	Yes ⁴	≤72	TBD	TBD	
		>72	TBD	TBD	
	No ⁵	All	TBD	N/A	
CA_12A-30A-66A	PCC	Yes ⁴	≤72	TBD	TBD
			>72	TBD	TBD
		No ⁵	All	TBD	N/A
	SCC1	Yes ⁴	≤72	TBD	TBD
			>72	TBD	TBD
	No ⁵	All	TBD	N/A	
SCC2	Yes ⁴	≤72	TBD	TBD	
		>72	TBD	TBD	
	No ⁵	All	TBD	N/A	

TABLE 6-28 LTE MAXIMUM C-TIS LEVEL REQUIREMENTS FOR PCC, SCC1, AND SCC2 IN CARRIER AGGREGATION MODE (3 DOWNLINK CARRIERS, 1 UPLINK CARRIER) FOR THE PRIMARY MECHANICAL MODE¹

Carrier Aggregation Combination	PCC / SCC	Device Held Up to Head for Voice (Yes/No)	Device Width (mm) ²	Free Space	HL and HR
CA_12A-66C	PCC	Yes ⁴	≤72	TBD	TBD
			>72	TBD	TBD
	No ⁵	All	TBD	N/A	
	SCC1	Yes ⁴	≤72	TBD	TBD
			>72	TBD	TBD
No ⁵	All	TBD	N/A		
SCC2	Yes ⁴	≤72	TBD	TBD	
		>72	TBD	TBD	
No ⁵	All	TBD	N/A		
CA_12A-66A-66A	PCC	Yes ⁴	≤72	TBD	TBD
			>72	TBD	TBD
	No ⁵	All	TBD	N/A	
	SCC1	Yes ⁴	≤72	TBD	TBD
			>72	TBD	TBD
No ⁵	All	TBD	N/A		
SCC2	Yes ⁴	≤72	TBD	TBD	
		>72	TBD	TBD	
No ⁵	All	TBD	N/A		
CA_13A-2A-2A	PCC	Yes ⁴	≤72	TBD	TBD
			>72	TBD	TBD
	No ⁵	All	TBD	N/A	
	SCC1	Yes ⁴	≤72	TBD	TBD
			>72	TBD	TBD
No ⁵	All	TBD	N/A		
SCC2	Yes ⁴	≤72	TBD	TBD	
		>72	TBD	TBD	
No ⁵	All	TBD	N/A		

TABLE 6-28 LTE MAXIMUM C-TIS LEVEL REQUIREMENTS FOR PCC, SCC1, AND SCC2 IN CARRIER AGGREGATION MODE (3 DOWNLINK CARRIERS, 1 UPLINK CARRIER) FOR THE PRIMARY MECHANICAL MODE¹

Carrier Aggregation Combination	PCC / SCC	Device Held Up to Head for Voice (Yes/No)	Device Width (mm) ²	Free Space	HL and HR
CA_13A-2A-4A	PCC	Yes ⁴	≤72	TBD	TBD
			>72	TBD	TBD
	No ⁵	All	TBD	N/A	
	SCC1	Yes ⁴	≤72	TBD	TBD
			>72	TBD	TBD
No ⁵	All	TBD	N/A		
SCC2	Yes ⁴	≤72	TBD	TBD	
		>72	TBD	TBD	
No ⁵	All	TBD	N/A		
CA_13A-2A-48A	PCC	Yes ⁴	≤72	TBD	TBD
			>72	TBD	TBD
	No ⁵	All	TBD	N/A	
	SCC1	Yes ⁴	≤72	TBD	TBD
			>72	TBD	TBD
No ⁵	All	TBD	N/A		
SCC2	Yes ⁴	≤72	TBD	TBD	
		>72	TBD	TBD	
No ⁵	All	TBD	N/A		
CA_13A-2A-66A	PCC	Yes ⁴	≤72	TBD	TBD
			>72	TBD	TBD
	No ⁵	All	TBD	N/A	
	SCC1	Yes ⁴	≤72	TBD	TBD
			>72	TBD	TBD
No ⁵	All	TBD	N/A		
SCC2	Yes ⁴	≤72	TBD	TBD	
		>72	TBD	TBD	
No ⁵	All	TBD	N/A		

TABLE 6-28 LTE MAXIMUM C-TIS LEVEL REQUIREMENTS FOR PCC, SCC1, AND SCC2 IN CARRIER AGGREGATION MODE (3 DOWNLINK CARRIERS, 1 UPLINK CARRIER) FOR THE PRIMARY MECHANICAL MODE¹

Carrier Aggregation Combination	PCC / SCC	Device Held Up to Head for Voice (Yes/No)	Device Width (mm) ²	Free Space	HL and HR
CA_13A-4A-4A	PCC	Yes ⁴	≤72	TBD	TBD
			>72	TBD	TBD
	No ⁵	All	TBD	N/A	
	SCC1	Yes ⁴	≤72	TBD	TBD
			>72	TBD	TBD
No ⁵	All	TBD	N/A		
SCC2	Yes ⁴	≤72	TBD	TBD	
		>72	TBD	TBD	
No ⁵	All	TBD	N/A		
CA_13A-48A-66A	PCC	Yes ⁴	≤72	TBD	TBD
			>72	TBD	TBD
	No ⁵	All	TBD	N/A	
	SCC1	Yes ⁴	≤72	TBD	TBD
			>72	TBD	TBD
No ⁵	All	TBD	N/A		
SCC2	Yes ⁴	≤72	TBD	TBD	
		>72	TBD	TBD	
No ⁵	All	TBD	N/A		
CA_13A-66C	PCC	Yes ⁴	≤72	TBD	TBD
			>72	TBD	TBD
	No ⁵	All	TBD	N/A	
	SCC1	Yes ⁴	≤72	TBD	TBD
			>72	TBD	TBD
No ⁵	All	TBD	N/A		
SCC2	Yes ⁴	≤72	TBD	TBD	
		>72	TBD	TBD	
No ⁵	All	TBD	N/A		

TABLE 6-28 LTE MAXIMUM C-TIS LEVEL REQUIREMENTS FOR PCC, SCC1, AND SCC2 IN CARRIER AGGREGATION MODE (3 DOWNLINK CARRIERS, 1 UPLINK CARRIER) FOR THE PRIMARY MECHANICAL MODE¹

Carrier Aggregation Combination	PCC / SCC	Device Held Up to Head for Voice (Yes/No)	Device Width (mm) ²	Free Space	HL and HR
CA_13A-66A-66A	PCC	Yes ⁴	≤72	TBD	TBD
			>72	TBD	TBD
		No ⁵	All	TBD	N/A
	SCC1	Yes ⁴	≤72	TBD	TBD
			>72	TBD	TBD
	No ⁵	All	TBD	N/A	
SCC2	Yes ⁴	≤72	TBD	TBD	
		>72	TBD	TBD	
	No ⁵	All	TBD	N/A	
CA_25A-41C	PCC	Yes ⁴	≤72	TBD	TBD
			>72	TBD	TBD
		No ⁵	All	TBD	N/A
	SCC1	Yes ⁴	≤72	TBD	TBD
			>72	TBD	TBD
	No ⁵	All	TBD	N/A	
SCC2	Yes ⁴	≤72	TBD	TBD	
		>72	TBD	TBD	
	No ⁵	All	TBD	N/A	
CA_30A-2A-5A	PCC	Yes ⁴	≤72	TBD	TBD
			>72	TBD	TBD
		No ⁵	All	TBD	N/A
	SCC1	Yes ⁴	≤72	TBD	TBD
			>72	TBD	TBD
	No ⁵	All	TBD	N/A	
SCC2	Yes ⁴	≤72	TBD	TBD	
		>72	TBD	TBD	
	No ⁵	All	TBD	N/A	

TABLE 6-28 LTE MAXIMUM C-TIS LEVEL REQUIREMENTS FOR PCC, SCC1, AND SCC2 IN CARRIER AGGREGATION MODE (3 DOWNLINK CARRIERS, 1 UPLINK CARRIER) FOR THE PRIMARY MECHANICAL MODE¹

Carrier Aggregation Combination	PCC / SCC	Device Held Up to Head for Voice (Yes/No)	Device Width (mm) ²	Free Space	HL and HR
CA_30A-2A-12A	PCC	Yes ⁴	≤72	TBD	TBD
			>72	TBD	TBD
		No ⁵	All	TBD	N/A
	SCC1	Yes ⁴	≤72	TBD	TBD
			>72	TBD	TBD
	No ⁵	All	TBD	N/A	
SCC2	Yes ⁴	≤72	TBD	TBD	
		>72	TBD	TBD	
	No ⁵	All	TBD	N/A	
CA_30A-2A-29A	PCC	Yes ⁴	≤72	TBD	TBD
			>72	TBD	TBD
		No ⁵	All	TBD	N/A
	SCC1	Yes ⁴	≤72	TBD	TBD
			>72	TBD	TBD
	No ⁵	All	TBD	N/A	
SCC2	Yes ⁴	≤72	TBD	TBD	
		>72	TBD	TBD	
	No ⁵	All	TBD	N/A	
CA_30A-4A-5A	PCC	Yes ⁴	≤72	TBD	TBD
			>72	TBD	TBD
		No ⁵	All	TBD	N/A
	SCC1	Yes ⁴	≤72	TBD	TBD
			>72	TBD	TBD
	No ⁵	All	TBD	N/A	
SCC2	Yes ⁴	≤72	TBD	TBD	
		>72	TBD	TBD	
	No ⁵	All	TBD	N/A	

TABLE 6-28 LTE MAXIMUM C-TIS LEVEL REQUIREMENTS FOR PCC, SCC1, AND SCC2 IN CARRIER AGGREGATION MODE (3 DOWNLINK CARRIERS, 1 UPLINK CARRIER) FOR THE PRIMARY MECHANICAL MODE¹

Carrier Aggregation Combination	PCC / SCC	Device Held Up to Head for Voice (Yes/No)	Device Width (mm) ²	Free Space	HL and HR
CA_30A-4A-12A	PCC	Yes ⁴	≤72	TBD	TBD
			>72	TBD	TBD
		No ⁵	All	TBD	N/A
	SCC1	Yes ⁴	≤72	TBD	TBD
			>72	TBD	TBD
	No ⁵	All	TBD	N/A	
SCC2	Yes ⁴	≤72	TBD	TBD	
		>72	TBD	TBD	
	No ⁵	All	TBD	N/A	
CA_30A-4A-29A	PCC	Yes ⁴	≤72	TBD	TBD
			>72	TBD	TBD
		No ⁵	All	TBD	N/A
	SCC1	Yes ⁴	≤72	TBD	TBD
			>72	TBD	TBD
	No ⁵	All	TBD	N/A	
SCC2	Yes ⁴	≤72	TBD	TBD	
		>72	TBD	TBD	
	No ⁵	All	TBD	N/A	
CA_30A-5A-29A	PCC	Yes ⁴	≤72	TBD	TBD
			>72	TBD	TBD
		No ⁵	All	TBD	N/A
	SCC1	Yes ⁴	≤72	TBD	TBD
			>72	TBD	TBD
	No ⁵	All	TBD	N/A	
SCC2	Yes ⁴	≤72	TBD	TBD	
		>72	TBD	TBD	
	No ⁵	All	TBD	N/A	

TABLE 6-28 LTE MAXIMUM C-TIS LEVEL REQUIREMENTS FOR PCC, SCC1, AND SCC2 IN CARRIER AGGREGATION MODE (3 DOWNLINK CARRIERS, 1 UPLINK CARRIER) FOR THE PRIMARY MECHANICAL MODE¹

Carrier Aggregation Combination	PCC / SCC	Device Held Up to Head for Voice (Yes/No)	Device Width (mm) ²	Free Space	HL and HR
CA_30A-5A-66A	PCC	Yes ⁴	≤72	TBD	TBD
			>72	TBD	TBD
	No ⁵	All	TBD	N/A	
	SCC1	Yes ⁴	≤72	TBD	TBD
			>72	TBD	TBD
No ⁵	All	TBD	N/A		
SCC2	Yes ⁴	≤72	TBD	TBD	
		>72	TBD	TBD	
No ⁵	All	TBD	N/A		
CA_30A-12A-66A	PCC	Yes ⁴	≤72	TBD	TBD
			>72	TBD	TBD
	No ⁵	All	TBD	N/A	
	SCC1	Yes ⁴	≤72	TBD	TBD
			>72	TBD	TBD
No ⁵	All	TBD	N/A		
SCC2	Yes ⁴	≤72	TBD	TBD	
		>72	TBD	TBD	
No ⁵	All	TBD	N/A		
CA_30A-29A-66A	PCC	Yes ⁴	≤72	TBD	TBD
			>72	TBD	TBD
	No ⁵	All	TBD	N/A	
	SCC1	Yes ⁴	≤72	TBD	TBD
			>72	TBD	TBD
No ⁵	All	TBD	N/A		
SCC2	Yes ⁴	≤72	TBD	TBD	
		>72	TBD	TBD	
No ⁵	All	TBD	N/A		

TABLE 6-28 LTE MAXIMUM C-TIS LEVEL REQUIREMENTS FOR PCC, SCC1, AND SCC2 IN CARRIER AGGREGATION MODE (3 DOWNLINK CARRIERS, 1 UPLINK CARRIER) FOR THE PRIMARY MECHANICAL MODE¹

Carrier Aggregation Combination	PCC / SCC	Device Held Up to Head for Voice (Yes/No)	Device Width (mm) ²	Free Space	HL and HR
CA_30A-66C	PCC	Yes ⁴	≤72	TBD	TBD
			>72	TBD	TBD
		No ⁵	All	TBD	N/A
	SCC1	Yes ⁴	≤72	TBD	TBD
			>72	TBD	TBD
	No ⁵	All	TBD	N/A	
SCC2	Yes ⁴	≤72	TBD	TBD	
		>72	TBD	TBD	
	No ⁵	All	TBD	N/A	
CA_30A-66A-66A	PCC	Yes ⁴	≤72	TBD	TBD
			>72	TBD	TBD
		No ⁵	All	TBD	N/A
	SCC1	Yes ⁴	≤72	TBD	TBD
			>72	TBD	TBD
	No ⁵	All	TBD	N/A	
SCC2	Yes ⁴	≤72	TBD	TBD	
		>72	TBD	TBD	
	No ⁵	All	TBD	N/A	
CA_41D	PCC	Yes ⁴	≤72	TBD	TBD
			>72	TBD	TBD
		No ⁵	All	TBD	N/A
	SCC1	Yes ⁴	≤72	TBD	TBD
			>72	TBD	TBD
	No ⁵	All	TBD	N/A	
SCC2	Yes ⁴	≤72	TBD	TBD	
		>72	TBD	TBD	
	No ⁵	All	TBD	N/A	

TABLE 6-28 LTE MAXIMUM C-TIS LEVEL REQUIREMENTS FOR PCC, SCC1, AND SCC2 IN CARRIER AGGREGATION MODE (3 DOWNLINK CARRIERS, 1 UPLINK CARRIER) FOR THE PRIMARY MECHANICAL MODE¹

Carrier Aggregation Combination	PCC / SCC	Device Held Up to Head for Voice (Yes/No)	Device Width (mm) ²	Free Space	HL and HR
CA_48A-2A-5A	PCC	Yes ⁴	≤72	TBD	TBD
			>72	TBD	TBD
		No ⁵	All	TBD	N/A
	SCC1	Yes ⁴	≤72	TBD	TBD
			>72	TBD	TBD
	No ⁵	All	TBD	N/A	
SCC2	Yes ⁴	≤72	TBD	TBD	
		>72	TBD	TBD	
	No ⁵	All	TBD	N/A	
CA_48A-2A-13A	PCC	Yes ⁴	≤72	TBD	TBD
			>72	TBD	TBD
		No ⁵	All	TBD	N/A
	SCC1	Yes ⁴	≤72	TBD	TBD
			>72	TBD	TBD
	No ⁵	All	TBD	N/A	
SCC2	Yes ⁴	≤72	TBD	TBD	
		>72	TBD	TBD	
	No ⁵	All	TBD	N/A	
CA_48A-2A-66A	PCC	Yes ⁴	≤72	TBD	TBD
			>72	TBD	TBD
		No ⁵	All	TBD	N/A
	SCC1	Yes ⁴	≤72	TBD	TBD
			>72	TBD	TBD
	No ⁵	All	TBD	N/A	
SCC2	Yes ⁴	≤72	TBD	TBD	
		>72	TBD	TBD	
	No ⁵	All	TBD	N/A	

TABLE 6-28 LTE MAXIMUM C-TIS LEVEL REQUIREMENTS FOR PCC, SCC1, AND SCC2 IN CARRIER AGGREGATION MODE (3 DOWNLINK CARRIERS, 1 UPLINK CARRIER) FOR THE PRIMARY MECHANICAL MODE¹

Carrier Aggregation Combination	PCC / SCC	Device Held Up to Head for Voice (Yes/No)	Device Width (mm) ²	Free Space	HL and HR
CA_48A-5A-66A	PCC	Yes ⁴	≤72	TBD	TBD
			>72	TBD	TBD
	No ⁵	All	TBD	N/A	
	SCC1	Yes ⁴	≤72	TBD	TBD
			>72	TBD	TBD
No ⁵	All	TBD	N/A		
SCC2	Yes ⁴	≤72	TBD	TBD	
		>72	TBD	TBD	
No ⁵	All	TBD	N/A		
CA_48A-13A-66A	PCC	Yes ⁴	≤72	TBD	TBD
			>72	TBD	TBD
	No ⁵	All	TBD	N/A	
	SCC1	Yes ⁴	≤72	TBD	TBD
			>72	TBD	TBD
No ⁵	All	TBD	N/A		
SCC2	Yes ⁴	≤72	TBD	TBD	
		>72	TBD	TBD	
No ⁵	All	TBD	N/A		
CA_66A-2A-2A	PCC	Yes ⁴	≤72	TBD	TBD
			>72	TBD	TBD
	No ⁵	All	TBD	N/A	
	SCC1	Yes ⁴	≤72	TBD	TBD
			>72	TBD	TBD
No ⁵	All	TBD	N/A		
SCC2	Yes ⁴	≤72	TBD	TBD	
		>72	TBD	TBD	
No ⁵	All	TBD	N/A		

TABLE 6-28 LTE MAXIMUM C-TIS LEVEL REQUIREMENTS FOR PCC, SCC1, AND SCC2 IN CARRIER AGGREGATION MODE (3 DOWNLINK CARRIERS, 1 UPLINK CARRIER) FOR THE PRIMARY MECHANICAL MODE¹

Carrier Aggregation Combination	PCC / SCC	Device Held Up to Head for Voice (Yes/No)	Device Width (mm) ²	Free Space	HL and HR
CA_66A-2A-5A	PCC	Yes ⁴	≤72	TBD	TBD
			>72	TBD	TBD
	No ⁵	All	TBD	N/A	
	SCC1	Yes ⁴	≤72	TBD	TBD
			>72	TBD	TBD
No ⁵	All	TBD	N/A		
CA_66A-2A-12A	PCC	Yes ⁴	≤72	TBD	TBD
			>72	TBD	TBD
	No ⁵	All	TBD	N/A	
	SCC1	Yes ⁴	≤72	TBD	TBD
			>72	TBD	TBD
No ⁵	All	TBD	N/A		
CA_66A-2A-13A	PCC	Yes ⁴	≤72	TBD	TBD
			>72	TBD	TBD
	No ⁵	All	TBD	N/A	
	SCC1	Yes ⁴	≤72	TBD	TBD
			>72	TBD	TBD
No ⁵	All	TBD	N/A		
CA_66A-2A-13A	SCC2	Yes ⁴	≤72	TBD	TBD
			>72	TBD	TBD
	No ⁵	All	TBD	N/A	

TABLE 6-28 LTE MAXIMUM C-TIS LEVEL REQUIREMENTS FOR PCC, SCC1, AND SCC2 IN CARRIER AGGREGATION MODE (3 DOWNLINK CARRIERS, 1 UPLINK CARRIER) FOR THE PRIMARY MECHANICAL MODE¹

Carrier Aggregation Combination	PCC / SCC	Device Held Up to Head for Voice (Yes/No)	Device Width (mm) ²	Free Space	HL and HR
CA_66A-2A-48A	PCC	Yes ⁴	≤72	TBD	TBD
			>72	TBD	TBD
	No ⁵	All	TBD	N/A	
	SCC1	Yes ⁴	≤72	TBD	TBD
			>72	TBD	TBD
No ⁵	All	TBD	N/A		
SCC2	Yes ⁴	≤72	TBD	TBD	
		>72	TBD	TBD	
No ⁵	All	TBD	N/A		
CA_66C-2A	PCC	Yes ⁴	≤72	TBD	TBD
			>72	TBD	TBD
	No ⁵	All	TBD	N/A	
	SCC1	Yes ⁴	≤72	TBD	TBD
			>72	TBD	TBD
No ⁵	All	TBD	N/A		
SCC2	Yes ⁴	≤72	TBD	TBD	
		>72	TBD	TBD	
No ⁵	All	TBD	N/A		
CA_66A-2A-66A	PCC	Yes ⁴	≤72	TBD	TBD
			>72	TBD	TBD
	No ⁵	All	TBD	N/A	
	SCC1	Yes ⁴	≤72	TBD	TBD
			>72	TBD	TBD
No ⁵	All	TBD	N/A		
SCC2	Yes ⁴	≤72	TBD	TBD	
		>72	TBD	TBD	
No ⁵	All	TBD	N/A		

TABLE 6-28 LTE MAXIMUM C-TIS LEVEL REQUIREMENTS FOR PCC, SCC1, AND SCC2 IN CARRIER AGGREGATION MODE (3 DOWNLINK CARRIERS, 1 UPLINK CARRIER) FOR THE PRIMARY MECHANICAL MODE¹

Carrier Aggregation Combination	PCC / SCC	Device Held Up to Head for Voice (Yes/No)	Device Width (mm) ²	Free Space	HL and HR
CA_66A-5A-5A	PCC	Yes ⁴	≤72	TBD	TBD
			>72	TBD	TBD
	No ⁵	All	TBD	N/A	
	SCC1	Yes ⁴	≤72	TBD	TBD
			>72	TBD	TBD
No ⁵	All	TBD	N/A		
SCC2	Yes ⁴	≤72	TBD	TBD	
		>72	TBD	TBD	
No ⁵	All	TBD	N/A		
CA_66A-5A-48A	PCC	Yes ⁴	≤72	TBD	TBD
			>72	TBD	TBD
	No ⁵	All	TBD	N/A	
	SCC1	Yes ⁴	≤72	TBD	TBD
			>72	TBD	TBD
No ⁵	All	TBD	N/A		
SCC2	Yes ⁴	≤72	TBD	TBD	
		>72	TBD	TBD	
No ⁵	All	TBD	N/A		
CA_66C-5A	PCC	Yes ⁴	≤72	TBD	TBD
			>72	TBD	TBD
	No ⁵	All	TBD	N/A	
	SCC1	Yes ⁴	≤72	TBD	TBD
			>72	TBD	TBD
No ⁵	All	TBD	N/A		
SCC2	Yes ⁴	≤72	TBD	TBD	
		>72	TBD	TBD	
No ⁵	All	TBD	N/A		

TABLE 6-28 LTE MAXIMUM C-TIS LEVEL REQUIREMENTS FOR PCC, SCC1, AND SCC2 IN CARRIER AGGREGATION MODE (3 DOWNLINK CARRIERS, 1 UPLINK CARRIER) FOR THE PRIMARY MECHANICAL MODE¹

Carrier Aggregation Combination	PCC / SCC	Device Held Up to Head for Voice (Yes/No)	Device Width (mm) ²	Free Space	HL and HR
CA_66A-5A-66A	PCC	Yes ⁴	≤72	TBD	TBD
			>72	TBD	TBD
		No ⁵	All	TBD	N/A
	SCC1	Yes ⁴	≤72	TBD	TBD
			>72	TBD	TBD
	No ⁵	All	TBD	N/A	
SCC2	Yes ⁴	≤72	TBD	TBD	
		>72	TBD	TBD	
	No ⁵	All	TBD	N/A	
CA_66A-12A-29A	PCC	Yes ⁴	≤72	TBD	TBD
			>72	TBD	TBD
		No ⁵	All	TBD	N/A
	SCC1	Yes ⁴	≤72	TBD	TBD
			>72	TBD	TBD
	No ⁵	All	TBD	N/A	
SCC2	Yes ⁴	≤72	TBD	TBD	
		>72	TBD	TBD	
	No ⁵	All	TBD	N/A	
CA_66A-12A-30A	PCC	Yes ⁴	≤72	TBD	TBD
			>72	TBD	TBD
		No ⁵	All	TBD	N/A
	SCC1	Yes ⁴	≤72	TBD	TBD
			>72	TBD	TBD
	No ⁵	All	TBD	N/A	
SCC2	Yes ⁴	≤72	TBD	TBD	
		>72	TBD	TBD	
	No ⁵	All	TBD	N/A	

TABLE 6-28 LTE MAXIMUM C-TIS LEVEL REQUIREMENTS FOR PCC, SCC1, AND SCC2 IN CARRIER AGGREGATION MODE (3 DOWNLINK CARRIERS, 1 UPLINK CARRIER) FOR THE PRIMARY MECHANICAL MODE¹

Carrier Aggregation Combination	PCC / SCC	Device Held Up to Head for Voice (Yes/No)	Device Width (mm) ²	Free Space	HL and HR
CA_66C-12A	PCC	Yes ⁴	≤72	TBD	TBD
			>72	TBD	TBD
	No ⁵	All	TBD	N/A	
	SCC1	Yes ⁴	≤72	TBD	TBD
			>72	TBD	TBD
No ⁵	All	TBD	N/A		
CA_66A-12A-66A	PCC	Yes ⁴	≤72	TBD	TBD
			>72	TBD	TBD
	No ⁵	All	TBD	N/A	
	SCC1	Yes ⁴	≤72	TBD	TBD
			>72	TBD	TBD
No ⁵	All	TBD	N/A		
CA_66A-13A-48A	PCC	Yes ⁴	≤72	TBD	TBD
			>72	TBD	TBD
	No ⁵	All	TBD	N/A	
	SCC1	Yes ⁴	≤72	TBD	TBD
			>72	TBD	TBD
No ⁵	All	TBD	N/A		
CA_66A-13A-48A	SCC2	Yes ⁴	≤72	TBD	TBD
			>72	TBD	TBD
	No ⁵	All	TBD	N/A	

TABLE 6-28 LTE MAXIMUM C-TIS LEVEL REQUIREMENTS FOR PCC, SCC1, AND SCC2 IN CARRIER AGGREGATION MODE (3 DOWNLINK CARRIERS, 1 UPLINK CARRIER) FOR THE PRIMARY MECHANICAL MODE¹

Carrier Aggregation Combination	PCC / SCC	Device Held Up to Head for Voice (Yes/No)	Device Width (mm) ²	Free Space	HL and HR
CA_66C-13A	PCC	Yes ⁴	≤72	TBD	TBD
			>72	TBD	TBD
	No ⁵	All	TBD	N/A	
	SCC1	Yes ⁴	≤72	TBD	TBD
			>72	TBD	TBD
No ⁵	All	TBD	N/A		
CA_66A-13A-66A	PCC	Yes ⁴	≤72	TBD	TBD
			>72	TBD	TBD
	No ⁵	All	TBD	N/A	
	SCC1	Yes ⁴	≤72	TBD	TBD
			>72	TBD	TBD
No ⁵	All	TBD	N/A		
CA_66A-29A-30A	PCC	Yes ⁴	≤72	TBD	TBD
			>72	TBD	TBD
	No ⁵	All	TBD	N/A	
	SCC1	Yes ⁴	≤72	TBD	TBD
			>72	TBD	TBD
No ⁵	All	TBD	N/A		
CA_66A-29A-30A	SCC2	Yes ⁴	≤72	TBD	TBD
			>72	TBD	TBD
	No ⁵	All	TBD	N/A	

TABLE 6-28 LTE MAXIMUM C-TIS LEVEL REQUIREMENTS FOR PCC, SCC1, AND SCC2 IN CARRIER AGGREGATION MODE (3 DOWNLINK CARRIERS, 1 UPLINK CARRIER) FOR THE PRIMARY MECHANICAL MODE¹

Carrier Aggregation Combination	PCC / SCC	Device Held Up to Head for Voice (Yes/No)	Device Width (mm) ²	Free Space	HL and HR
CA_66C-29A	PCC	Yes ⁴	≤72	TBD	TBD
			>72	TBD	TBD
	No ⁵	All	TBD	N/A	
	SCC1	Yes ⁴	≤72	TBD	TBD
			>72	TBD	TBD
No ⁵	All	TBD	N/A		
SCC2	Yes ⁴	≤72	TBD	TBD	
		>72	TBD	TBD	
No ⁵	All	TBD	N/A		
CA_66A-29A-66A	PCC	Yes ⁴	≤72	TBD	TBD
			>72	TBD	TBD
	No ⁵	All	TBD	N/A	
	SCC1	Yes ⁴	≤72	TBD	TBD
			>72	TBD	TBD
No ⁵	All	TBD	N/A		
SCC2	Yes ⁴	≤72	TBD	TBD	
		>72	TBD	TBD	
No ⁵	All	TBD	N/A		
CA_66C-30A	PCC	Yes ⁴	≤72	TBD	TBD
			>72	TBD	TBD
	No ⁵	All	TBD	N/A	
	SCC1	Yes ⁴	≤72	TBD	TBD
			>72	TBD	TBD
No ⁵	All	TBD	N/A		
SCC2	Yes ⁴	≤72	TBD	TBD	
		>72	TBD	TBD	
No ⁵	All	TBD	N/A		

TABLE 6-28 LTE MAXIMUM C-TIS LEVEL REQUIREMENTS FOR PCC, SCC1, AND SCC2 IN CARRIER AGGREGATION MODE (3 DOWNLINK CARRIERS, 1 UPLINK CARRIER) FOR THE PRIMARY MECHANICAL MODE¹

Carrier Aggregation Combination	PCC / SCC	Device Held Up to Head for Voice (Yes/No)	Device Width (mm) ²	Free Space	HL and HR
CA_66A-30A-66A	PCC	Yes ⁴	≤72	TBD	TBD
			>72	TBD	TBD
	No ⁵	All	TBD	N/A	
	SCC1	Yes ⁴	≤72	TBD	TBD
			>72	TBD	TBD
No ⁵	All	TBD	N/A		
SCC2	Yes ⁴	≤72	TBD	TBD	
		>72	TBD	TBD	
No ⁵	All	TBD	N/A		
CA_66D	PCC	Yes ⁴	≤72	TBD	TBD
			>72	TBD	TBD
	No ⁵	All	TBD	N/A	
	SCC1	Yes ⁴	≤72	TBD	TBD
			>72	TBD	TBD
No ⁵	All	TBD	N/A		
SCC2	Yes ⁴	≤72	TBD	TBD	
		>72	TBD	TBD	
No ⁵	All	TBD	N/A		
CA_66C-66A	PCC	Yes ⁴	≤72	TBD	TBD
			>72	TBD	TBD
	No ⁵	All	TBD	N/A	
	SCC1	Yes ⁴	≤72	TBD	TBD
			>72	TBD	TBD
No ⁵	All	TBD	N/A		
SCC2	Yes ⁴	≤72	TBD	TBD	
		>72	TBD	TBD	
No ⁵	All	TBD	N/A		

TABLE 6-28 LTE MAXIMUM C-TIS LEVEL REQUIREMENTS FOR PCC, SCC1, AND SCC2 IN CARRIER AGGREGATION MODE (3 DOWNLINK CARRIERS, 1 UPLINK CARRIER) FOR THE PRIMARY MECHANICAL MODE¹

Carrier Aggregation Combination	PCC / SCC	Device Held Up to Head for Voice (Yes/No)	Device Width (mm) ²	Free Space	HL and HR
CA_66A-66C	PCC	Yes ⁴	≤72	TBD	TBD
			>72	TBD	TBD
		No ⁵	All	TBD	N/A
	SCC1	Yes ⁴	≤72	TBD	TBD
			>72	TBD	TBD
		No ⁵	All	TBD	N/A
	SCC2	Yes ⁴	≤72	TBD	TBD
			>72	TBD	TBD
		No ⁵	All	TBD	N/A

Note 1: Primary Mechanical Mode refers to device configured in preferred mode per manufacturer instructions (typically means antenna extended, fold or portrait slide open, but depends on form factor).
Note 2: Differences between requirements for devices wider and narrower than 72 mm reflect observed differences in OTA performance with different hand phantoms of up to 6 dB.
Note 3: Different limits for different channel combinations may be needed since the desense effects will be channel dependent.
Note 4: "Yes" applies if the device supports voice operation in the talking position against the head in LTE mode.
Note 5: "No" would be applicable to data-centric devices that are not held up against the head, e.g., embedded laptop solutions.

6.18 MBS

6.18.1 Test Procedure

The procedure identified herein has been based on industry standards used during EUT conformance testing. However, some modifications were made to reduce test time, to reduce the Over-the-Air test solution complexity, and to account for specific Over-the-Air testing needs. The specific modifications are described in the corresponding cellular radio mode test specifics in [Section 6.18.5](#). It is assumed that the EUT will be tested per the conformance testing requirements defined by the industry standards. Therefore, any device that does not specifically meet the requirements of the industry standards would be identified during the conformance testing.

MBS Receiver Sensitivity measurements shall be performed using test equipment that supports the relevant standards defined herein. Unless otherwise specified, the latest versions of the referenced 3GPP documents shall be used. The EUT's MBS receiver sensitivity will be the minimum MBS signal level that results in a passing result based on the relevant MBS test parameters defined herein.

The test will determine the Total Isotropic Sensitivity (TIS), the Near-Horizon Partial Isotropic Sensitivity considered over ± 45 degrees NHPIS _{± 45} and the Near-Horizon Partial Isotropic Sensitivity considered over ± 30 degrees NHPIS _{± 30} of the MBS receiver. The TIS test procedure based on receive signal strength derived from code phase RMS error as specified in [Section 6.15.4](#) will be used.

The test applies to UE-assisted MBS devices.

This test will consist of the following measurements:

- Radiated 3D RSS pattern measurement based on code phase RMS error
- Radiated MBS sensitivity measurement
- Radiated MBS intermediate channel degradation measurement

TIS, NHPIS_{±45}, and NHPIS_{±30} shall be fully measured as described in [Section 6.18.2.1](#) and [Section 6.18.3.1](#), and calculated pursuant to Appendices [B.3.3](#) and [B.3.4](#). When operating the device at the channels specified and in all frequency bands and cellular radio modes where the EUT supports MBS and as defined herein. In all cases, the linearized RSS measurements based on code phase RMS error values shall be used in the calculations.

For both the full TIS test and the MBS intermediate channel degradation test, head with hand phantom and/or hand phantom testing shall be conducted based on device type, as specified in [Appendix O](#). Refer to [Appendix C](#) for head and hand testing requirements. Perform each test in all functional use configurations, and with the EUT antenna extended and retracted, as applicable.

MBS OTA testing shall be performed with the device configured in its normal operating state with regards to the use of cellular diversity antennas.

6.18.2 Radiated 3D RSS Pattern Measurement

6.18.2.1 General

The pattern data shall be determined by averaging RSS measurements derived from code phase RMS error measurements of all visible MBS beacons for each measurement at each point on the sphere. For each measurement, RSS corresponds to:

$$20 \times \log_{10} \left(\frac{0.336 \times T_{chip}}{codephaseRMSError} \right)$$

in dB units and

$$\frac{0.336^2 \times T_{chip}^2}{codephaseRMSError^2}$$

in linear terms, where T_{chip} is 293.052 meters and $codephaseRMSError$ is the value in meters as specified in sub-clause 6.5.4.2 of the 3GPP 36.355 specification. The upper bound of the pseudo-range value given in the floating-point mapping is used. The MBS simulator shall provide the number of beacons specified herein and each beacon shall be at the same power. All code phase RMS error measurements shall be done with the MBS engine in a tracking mode or by using individual UE-assisted measurements. Orthogonal linear polarizations will be measured. For one measurement report, the RSS measurements derived based on the reported code phase RMS error values shall be averaged. If it is necessary to obtain more measurements to reduce uncertainty, repeat the measurement requests at the same position and polarization and independently average the RSS values corresponding to the reported code phase RMS error values for each measurement report. After a sufficient number of measurement requests have been made, average the average results that were obtained for each measurement request. Sufficient averaging shall be completed to ensure that the uncertainty is less than the value included in the uncertainty budget. The RSS pattern measurements shall be performed with any supported cellular radio mode using a low TX power to conserve battery power and to minimize

self-interference. The transmit power shall be guaranteed to be 10 dB or more below the maximum TX power.

The RSS pattern data shall be linearized per the linearization method specified in [Section 6.15.4.2](#) using code phase RMS error measurements. Note that when the Alternate Test Procedure for TIS Single Point Offset Test can be and is used for MBS testing, the 3D RSS patterns do not need to be measured and the linearization step does not need to be applied for other applicable operating bands and cellular radio modes.

6.18.3 Radiated MBS Sensitivity Measurement

6.18.3.1 General

The radiated MBS sensitivity search shall be performed at the position/polarization where the peak RSS value derived from the code phase RMS error value was obtained. The EUT's MBS receiver sensitivity will be the minimum MBS signal level that results in a passing result for the applicable MBS Sensitivity test specified herein. The maximum MBS sensitivity search step size shall be no more than 0.5 dB when the MBS beacon power level is near the MBS sensitivity level. The EUT shall be transmitting at maximum power at the declared MBS sensitivity level. The transmit power settings for maximum power shall be as defined in the cellular radio mode test specifics in [Section 6.18.5](#). In order to minimize test time, the EUT measurements may be performed on a single call as long as each EUT measurement report is the result of a separate request. The EUT is not required to be power cycled in between measurements. When operating in UE-assisted mode, the MBS information does have to be cleared in between measurement requests using the RESET function defined in 3GPP 36.509 for MBS. Refer to [Appendix A](#) for set-up illustrations.

The radiated sensitivity tests for a particular band/antenna configuration should be performed without disturbing the setup to minimize uncertainty in the sensitivity search. If the EUT will be disturbed during the test, a corresponding uncertainty component shall be included in the uncertainty budget.

6.18.3.2 Single Band Optimization

The Single Band Optimization is employed to minimize test time, by performing the radiated MBS sensitivity procedure in one band, chosen using specified criteria, and performing pass/fail checks for the remainder of the supported bands. The radiated MBS sensitivity measurement shall be performed at the position/polarization where the peak RSS value was obtained during the radiated 3D RSS pattern measurement for MBS for the band from the list in [Table 5-20](#) that is supported by the EUT, has the uplink closest to the M-LMS band and supports the narrowest channels, in each cellular radio mode and in each usage mode (BHHR, BHHL, HR, and HL) using the Alternate Test Procedure for TIS Single Point Offset Test specified in [Section 6.15.1](#). However, the Alternate Test Procedure for TIS Single Point Offset Test cannot be used with dynamically tuned MBS antennas when the tuning of the MBS antenna changes between the reference cellular protocol/band and with the protocol/band being evaluated. In the case with dynamically tuned MBS antennas, the MBS sensitivity measurement as defined above shall be made in the same cellular radio mode and operating band as the full MBS OTA sensitivity measurement and the alternative pass/fail test specified in the steps below shall not be used.

For all other operating bands within the same cellular radio mode and usage mode (BHHR, BHHL, HR, and HL), the following steps shall be performed.

1. Ensure that the chamber positioner(s) are positioned at the location & polarization where the peak RSS value was obtained during the radiated 3D RSS pattern measurement for MBS for the band from the list given in [Table 5-20](#) that is supported by the EUT, has the uplink closest to the M-LMS band and the narrowest supported channels.
2. Note the downlink power level which corresponds to the EUT's peak radiated MBS sensitivity as described in Step 1 above, which will be referred to as $MBS\ EIS_{(peak, reference\ band)}$.
3. Change to the test frequency associated with the next operating band for the cellular radio mode in use and adjust the MBS signal level to the RF power level calculated by the following formula:

EQUATION 6.26

$$MBS\ Signal\ Level\ (dBm) = MBS\ EIS_{(peak, reference\ band)}\ (dBm) +$$

$$MBS\ Linearized\ RSS_{(peak, band\ under\ test)}\ (dBm) - MBS\ Linearized\ RSS_{(peak, reference\ band)} + 3\ (dB)$$

4. Perform the MBS sensitivity procedure as defined in the cellular radio mode test specifics in [Section 6.18.5](#) with the exception that pass/fail will be determined at only the MBS signal level calculated in step 3.
5. Repeat steps 3 and 4 for each remaining operating band for the cellular radio mode in use.
6. Repeat steps 1 through 5 for each remaining cellular radio mode in the existing usage mode.
7. Repeat steps 1 through 6 for each remaining usage mode (BHHR, BHHL, HR, and HL) based on device type, as specified in [Appendix O](#). Perform each test with the EUT antenna extended and retracted, as applicable.
8. Report the pass/fail status of each measurement taken in step 4 above.

6.18.4 Radiated MBS Intermediate Channel Degradation Measurement

6.18.4.1 General

In addition to performing the sensitivity scan at the middle channel, the difference in sensitivity of the MBS receiver will be evaluated with the cellular transceiver active for all intermediate cellular channels. This difference in sensitivity will be determined by measuring the difference in the radiated RSS at the mid-channel and the radiated RSS result at each of the intermediate channels with the cellular transmitter active at maximum power. This test will be called the MBS intermediate channel degradation test.

For this test, the radiated RSS shall be measured at the position/polarization where the peak RSS was obtained.

The RSS measurements for each band/antenna configuration should be performed without disturbing the setup to minimize uncertainty in MBS intermediate channel degradation test. If the EUT will be disturbed during the test, a corresponding uncertainty component shall be included in the uncertainty budget.

The basic test sequence for performing this MBS intermediate channel degradation test is as follows:

1. Set up the beacon simulator with the number of beacons specified for the radiated 3D RSS pattern measurement at the same power. The MBS beacon power and scenario shall be set according to the recommendations in the cellular radio mode test specifics in [Section 6.18.5](#).

2. Enable a call using the appropriate cellular radio protocol.
3. Enable the MBS engine.
4. Obtain a MBS lock and start tracking.
5. Set the cellular radio channel to the middle channel and the transmit power level to maximum power as defined in the cellular radio mode test specifics in [Section 6.18.5](#).
6. Transmit the code phase RMS error of the visible MBS beacons over the existing cellular radio link. Record the averaged RSS based on the code phase RMS error of the visible MBS beacons. If additional measurements are required to minimize uncertainty, the measurements should be made prior to moving to the next step.
7. Calculate the average RSS (or average over repeated measurements of averages) and linearize the result using the data from the earlier linearization process. Change the cellular radio channel to a channel listed in [Appendix K](#) as applicable for the corresponding cellular radio mode and operating band. It is up to the implementer to determine how to change channels.
8. Transmit the code phase RMS error of the visible MBS beacons over the existing cellular radio link. Record the averaged RSS code phase RMS error of the visible MBS beacons. If additional measurements are required to minimize uncertainty, the measurements should be made prior to moving to the next step. Calculate the average RSS (or average over repeated measurements of averages) and linearize the result using the data from the earlier linearization process.
9. Repeat steps 7 and 8 for each channel listed in [Appendix K](#) as applicable for the corresponding cellular radio mode and operating band.
10. Repeat steps 5 through 9 for each cellular radio mode and operating band supported by the EUT.

Alternatively, the measurements defined above may be achieved by using the methodology defined for the radiated 3D RSS pattern measurement defined in [Section 6.18.2](#) except that transmit power level will be set to maximum power, as defined in the cellular radio mode test specifics in [Section 6.18.5](#).

The MBS intermediate channel degradation is the difference between the linearized average RSS (or average over repeated measurements of averages) with the transmitter at the mid-channel and the lowest linearized average RSS (or average over repeated measurements of averages) with the transmitter at any intermediate channel (including the mid-channel). Therefore, the MBS intermediate channel degradation will always be zero or greater. Report the MBS intermediate channel degradation.

As specified above, the average RSS measurement of all visible MBS beacons at each instance in time will be used. Sufficient averaging over time of measurements shall be completed to ensure that the uncertainty is less than the value specified in the lab's uncertainty budget.

$$MBS_{ICD} = \text{MBS degradation due to intermediate channel jamming}$$

$$RSS_{mid-channel} = \text{Linearized RSS with the mid-channel}$$

$$RSS_{min IC} = \text{minimum linearized RSS across all intermediate cellular channels}$$

$$MBS_{ICD} = RSS_{mid-channel} - RSS_{min IC} \text{ (in dB)}$$

6.18.5 Cellular Radio Mode Test Specifics

6.18.5.1 LTE

6.18.5.1.1 LTE MBS Testing: General

MBS Receiver Sensitivity measurements shall be performed using test equipment that supports the relevant portions of 3GPP TS 37.571. Unless otherwise specified, the latest versions of the referenced 3GPP documents shall be used.

MBS testing for LTE Devices will use either User Plane or Control Plane Positioning procedures. Testing is only required in either User Plane or Control Plane and the positioning procedure used for test shall be selected by the manufacturer. The selection should be made with input from the target operators. In the absence of operator input, then Control Plane Positioning procedures shall be used.

When utilizing User Plane Positioning procedures, MBS for LTE devices will be tested using the Open Mobile Alliance (OMA) Secure User Plane (SUPL) 2.0 protocol defined in OMA-AD-SUPL-V2_0 and OMA-TS-ULP-V2_0_3 with LPP used as the underlying positioning protocol for SUPL 2.0 over the LTE default bearer.

When utilizing User Plane Positioning procedures, the test applies to LTE devices supporting LPP positioning protocol. The test requires that the device support SUPL 2.0 as the User Plane protocol.

When utilizing Control Plane Positioning procedures, MBS for LTE devices will be tested using the LPP positioning protocol necessary for testing the Control Plane based tests in 3GPP TS 37.571-1 over the LTE default bearer.

[Table 6-15](#) specifies the mid-channel test channels and UL and DL allocations for LTE.

For the tests that operate at maximum output power, the UE transmit power shall be set to the maximum by sending continuous uplink power control “up” commands in every uplink scheduling information to the UE and allowing at least 200ms for the UE to reach its maximum level.

For the tests that do not operate at maximum output power such as the radiated 3D RSS pattern measurement, it is up to the implementer to utilize UE power control such that the requirement specified can be met.

The radiated MBS intermediate channel degradation measurements shall be made at the intermediate channels defined in [Appendix K.4](#).

Note: *Head-adjacent testing is only required for LTE if the EUT supports usage against the head in this mode (e.g., VoIP).*

6.18.5.1.2 MBS Test Procedure for LTE

For the MBS radiated 3D RSS pattern measurement and the MBS intermediate channel degradation measurement, the MBS simulator shall implement the scenario defined in 3GPP TS 37.571-1 subclause 11.3.5 except with modifications that the number of MBS beacons is 10 (one beacon in each of the 10

beacon slots in a transmission period) and the signal level is -110dBm, to facilitate linearization based on code phase RMS error.

The MBS radiated receiver sensitivity measurements shall be performed using the MBS 3GPP TS 37.571-1 Test Scenario 11.2.5, using the sample size and pass/fail criteria shown in [Table 6-29](#).

TABLE 6-29 SAMPLE SIZE AND PASS/FAIL CRITERIA FOR MBS SENSITIVITY SEARCH PROCEDURE

Pass criteria	At 33 test samples, 0 error samples OR At 46 test samples, 1 error sample OR At 58 test samples, 2 error samples OR At 69 test samples, 3 error samples OR At 79 test samples, 4 error samples OR At 89 test samples, 5 error samples OR At 100 test samples, 10 or fewer error samples
Fail criteria	At 100 or fewer test samples, 11 error samples

The test tolerance or test parameter relaxation for the absolute MBS signal level in C.2.3 in 3GPP TS 37.571-1 shall not be used in reporting the sensitivity measurement results. The MBS engine shall be cold started for every location attempt.

For MBS radiated receiver sensitivity measurements, the MBS simulator shall implement scenario as defined in 3GPP TS 37.571-1 Section 11.2.5.

The MBS radiated receiver sensitivity measurements will be performed for the LTE bands, channel numbers, and the allocations specified in [Table 6-15](#). If the device supports Band 25 and Band 2, then testing is only required to be completed in Band 25. If the device supports Band 26 and Band 5, then testing is only required to be completed in Band 26. If the device supports Band 12 and Band 17, then testing is only required to be completed in Band 12.

6.18.6 Criteria

Results shall be reported as specified in [Appendix B](#) using the figures of merit given in [Appendix B.3](#). "OTA 3.9.x Appendix B Tables" contains the pass/fail OTA tables for MBS. Reports shall include results applicable use cases, including free-space and/or head/hand configurations across all channels measured with the EUT antenna extended and retracted.

MBS intermediate channel degradation test results shall be provided in a file format equivalent to that specified in "OTA 3.9.x Appendix B Tables."

TABLE 6-30 MBS MAXIMUM TIS/NHPIS±45/NHPIS±30 LEVEL (IN DBM) REQUIREMENTS FOR THE PRIMARY MECHANICAL MODE¹

Cellular Band	Positioning Method	Device Width (mm) ²	BHHL and BHR			HL and HR		
			TIS	NHPIS ±45	NHPIS ±30	TIS	NHPIS ±45	NHPIS ±30
LTE Band 71	Control Plane/UE-Assisted	≤72	TBD	TBD	TBD	TBD	TBD	TBD
		>72	TBD	TBD	TBD	TBD	TBD	TBD
LTE Band 12		≤72	TBD	TBD	TBD	TBD	TBD	TBD
		>72	TBD	TBD	TBD	TBD	TBD	TBD
LTE Band 17		≤72	TBD	TBD	TBD	TBD	TBD	TBD
		>72	TBD	TBD	TBD	TBD	TBD	TBD
LTE Band 13		≤72	TBD	TBD	TBD	TBD	TBD	TBD
		>72	TBD	TBD	TBD	TBD	TBD	TBD
LTE Band 14		≤72	TBD	TBD	TBD	TBD	TBD	TBD
		>72	TBD	TBD	TBD	TBD	TBD	TBD
LTE Band 26		≤72	TBD	TBD	TBD	TBD	TBD	TBD
		>72	TBD	TBD	TBD	TBD	TBD	TBD
LTE Band 5		≤72	TBD	TBD	TBD	TBD	TBD	TBD
		>72	TBD	TBD	TBD	TBD	TBD	TBD
LTE Band 70		≤72	TBD	TBD	TBD	TBD	TBD	TBD
		>72	TBD	TBD	TBD	TBD	TBD	TBD
LTE Band 4		≤72	TBD	TBD	TBD	TBD	TBD	TBD
		>72	TBD	TBD	TBD	TBD	TBD	TBD
LTE Band 66		≤72	TBD	TBD	TBD	TBD	TBD	TBD
		>72	TBD	TBD	TBD	TBD	TBD	TBD
LTE Band 2	≤72	TBD	TBD	TBD	TBD	TBD	TBD	
	>72	TBD	TBD	TBD	TBD	TBD	TBD	
LTE Band 25	≤72	TBD	TBD	TBD	TBD	TBD	TBD	
	>72	TBD	TBD	TBD	TBD	TBD	TBD	
LTE Band 30	≤72	TBD	TBD	TBD	TBD	TBD	TBD	
	>72	TBD	TBD	TBD	TBD	TBD	TBD	
LTE Band 7	≤72	TBD	TBD	TBD	TBD	TBD	TBD	
	>72	TBD	TBD	TBD	TBD	TBD	TBD	
LTE Band 41	≤72	TBD	TBD	TBD	TBD	TBD	TBD	
	>72	TBD	TBD	TBD	TBD	TBD	TBD	

TABLE 6-30 MBS MAXIMUM TIS/NHPIS±45/NHPIS±30 LEVEL (IN DBM) REQUIREMENTS FOR THE PRIMARY MECHANICAL MODE¹

Cellular Band	Positioning Method	Device Width (mm) ²	BHHL and BHR			HL and HR		
			TIS	NHPIS ±45	NHPIS ±30	TIS	NHPIS ±45	NHPIS ±30
LTE Band 48	Control Plane/UE-Assisted	≤72	TBD	TBD	TBD	TBD	TBD	TBD
		>72	TBD	TBD	TBD	TBD	TBD	TBD
LTE Band 71	SUPL 2.0/ UE-Assisted	≤72	TBD	TBD	TBD	TBD	TBD	TBD
		>72	TBD	TBD	TBD	TBD	TBD	TBD
LTE Band 12		≤72	TBD	TBD	TBD	TBD	TBD	TBD
		>72	TBD	TBD	TBD	TBD	TBD	TBD
LTE Band 17		≤72	TBD	TBD	TBD	TBD	TBD	TBD
		>72	TBD	TBD	TBD	TBD	TBD	TBD
LTE Band 13		≤72	TBD	TBD	TBD	TBD	TBD	TBD
		>72	TBD	TBD	TBD	TBD	TBD	TBD
LTE Band 14		≤72	TBD	TBD	TBD	TBD	TBD	TBD
		>72	TBD	TBD	TBD	TBD	TBD	TBD
LTE Band 26		≤72	TBD	TBD	TBD	TBD	TBD	TBD
		>72	TBD	TBD	TBD	TBD	TBD	TBD
LTE Band 5		≤72	TBD	TBD	TBD	TBD	TBD	TBD
		>72	TBD	TBD	TBD	TBD	TBD	TBD
LTE Band 70		≤72	TBD	TBD	TBD	TBD	TBD	TBD
		>72	TBD	TBD	TBD	TBD	TBD	TBD
LTE Band 4		≤72	TBD	TBD	TBD	TBD	TBD	TBD
		>72	TBD	TBD	TBD	TBD	TBD	TBD
LTE Band 66		≤72	TBD	TBD	TBD	TBD	TBD	TBD
		>72	TBD	TBD	TBD	TBD	TBD	TBD
LTE Band 2	≤72	TBD	TBD	TBD	TBD	TBD	TBD	
	>72	TBD	TBD	TBD	TBD	TBD	TBD	
LTE Band 25	≤72	TBD	TBD	TBD	TBD	TBD	TBD	
	>72	TBD	TBD	TBD	TBD	TBD	TBD	

TABLE 6-30 MBS MAXIMUM TIS/NHPIS±45/NHPIS±30 LEVEL (IN DBM) REQUIREMENTS FOR THE PRIMARY MECHANICAL MODE¹

Cellular Band	Positioning Method	Device Width (mm) ²	BHHL and BHHR			HL and HR		
			TIS	NHPIS ±45	NHPIS ±30	TIS	NHPIS ±45	NHPIS ±30
LTE Band 30	SUPL 2.0/ UE-Assisted	≤72	TBD	TBD	TBD	TBD	TBD	TBD
		>72	TBD	TBD	TBD	TBD	TBD	TBD
LTE Band 7		≤72	TBD	TBD	TBD	TBD	TBD	TBD
		>72	TBD	TBD	TBD	TBD	TBD	TBD
LTE Band 41		≤72	TBD	TBD	TBD	TBD	TBD	TBD
		>72	TBD	TBD	TBD	TBD	TBD	TBD
LTE Band 48		≤72	TBD	TBD	TBD	TBD	TBD	TBD
		>72	TBD	TBD	TBD	TBD	TBD	TBD

Note 1: Primary Mechanical Mode refers to device configured in preferred mode per manufacturer instructions (typically means antenna extended, fold or portrait slide open, but depends on form factor).

Note 2: Differences between requirements for devices wider and narrower than 72 mm reflect observed differences in OTA performance with different hand phantoms of up to 6 dB.

6.19 Receiver Performance Testing of Devices with Antenna Switching

This section deals with devices that may switch one or more receivers between more than one antenna. The most common current application of such a scheme is in incidental support of TX Switched Diversity, wherein the transmit path is switched dynamically between different antennas, in order to optimize TX performance vs. hand presence or other time-variant impairment factors.

A common implementation for such a scheme is to switch the RF front-end path between a main and a diversity antenna, and a main transceiver port and diversity receiver port of the radio. Consequently, when the switch is toggled to direct the transmitter (main transceiver port) to one or the other antenna, the receivers are incidentally also swapped between the two antennas. In most implementations, both receivers remain active for either switch state; that is, the device continuously operates as a diversity receiver. In this case, assuming modern receiver technology like max-ratio-combining is implemented in the device and the receivers have equal conducted performance, the Combined TIS of the device would not change regardless of the switch state (to an ideal first order). In practice, with receiver impairments like transmit desense affecting each receiver to a different degree, the C-TIS values of the two switch states will begin to diverge.

There are of course many other hypothetical scenarios whereby antennas may be switched between receivers. For example, there may be cases where there is only one receiver and multiple antennas are switched to it (classically known as Antenna Switched RX Diversity, but could conceivably result from a TX Switched Diversity scheme where the device only has one receiver for the band/mode in question). In a most general case, a diversity device may have N receivers that are always active, and M ≥ N antennas that are mapped to those receivers at any point in time.

In general, the C-TIS value should be measured for each available switch state that is applicable to the use case under test, to ensure the full range of TIS performance possible in the field is characterized. Exceptions for test time reduction are made where applicable, for example if the manufacturer affirms that C-TIS (at maximum transmit power) is invariant across switch states.



For test time reduction, note that a single-point offset measurement can be used to characterize C-TIS for one cellular radio mode based on the fully measured C-TIS of another cellular radio mode only if the same antenna/receiver combination (switch state) is applied in both cellular radio modes.

Test reports shall be based on the existing reporting tables and also include the receiver/antenna and transmitter/antenna combination used.

6.19.1 Devices Where the Receiver Could Connect to a Different RX Antenna During the Execution of the Test Cases

These are devices where the choice of which RX antenna is connected to a receiver is either:

- Not a function of the use case of the device, e.g., the decision is made according to other parameters such as, but not limited to base station control, user control, Rx signal level or other means that originate external to the device, or
- A function of both the use case of the device and parameters that are not a function of the use case of the device, e.g., the decision depends on both body (head, hand) loading as well as the Rx signal level.

Such a device may change the connection of a receiver from one RX antenna to another antenna, but requires specific inputs from an external control source to do so. At this time, devices of this type must measure C-TIS for each antenna/receiver combination that produces a unique value as follows:

1. For the given device use case (i.e., FS, BHR/BHHL, HR/HL), band, and cellular radio mode wherein the device supports RX antenna switching, measure C-TIS (including intermediate channel desense testing) for the baseline antenna/receiver combination (switch state) as declared by the device manufacturer. The pass/fail criteria shall apply to this test case.
 2. For the additional antenna/receiver combinations (switch states) supported in the band and cellular radio mode:
 - a. if the device manufacturer declares that the free space C-TIS in step 1 differs by more than 1 dB from the free space C-TIS that would be obtained in the additional antenna/receiver combination in question: Results for additional antenna configurations shall be reported using duplicate tables with each table labeled to identify the antenna configuration tested.
Measure the free space C-TIS for the additional antenna/receiver combination (switch state). No pass/fail criteria shall be applied to this test case.
 - b. Otherwise, no additional testing is needed.
 3. If step 2 doesn't apply, then no additional C-TIS testing is required for any additional receiver/antenna combinations.
1. The manufacturer shall provide either:
 - a. Equipment and/or software which will allow the test lab to control which RX switch state is used. Or,
 - b. Otherwise identical test devices which are pre-configured for each RX switch state selection.
 2. The device manufacturer shall indicate which frequency bands and cellular radio mode support RX antenna switching in Table B-2, and specify the baseline antenna/receiver combination (switch state) to be tested first in the procedure above.

6.19.2 Devices Where the Receiver Does Not Switch to a Different Antenna During the Execution of the Test Cases

These are devices where the choice of which RX antenna is active is a function of the proximity to the user's hand, head or body, or nearby object and is usually determined by sensors contained within the device. Such a device will switch from one RX antenna to another based on the inputs it receives from its own self-contained sensors. The sensors may detect proximity of human tissue (hand, head or body) or may detect proximity of external objects (tables, seats, etc.). In such a device, it is required that the choice of RX antenna of the device remains the same during the C-TIS testing of the receiver/antenna combination (switch state) under test. Below are listed the basic requirements and conditions for two testing mode options, autonomous and non-autonomous defined for FS, BHHL, BHHR, HR, and HL test cases.

1. Autonomous Mode
 - a. If the manufacturer chooses, the device is allowed to operate in a fully autonomous mode where it actively chooses the receiver antenna combination depending on the test case during the C-TIS test.
2. Non-Autonomous Mode
 - a. a.The device manufacturer shall supply a "truth table" that clearly identifies which receiver-antenna combination will be used during C-TIS testing for all of the test cases (FS, BHHL, BHHR, HL, HR).
 - b. In addition, the manufacturer shall provide either:
 - i. Equipment and/or software which will allow the test lab to control which receiver-antenna combination is used for each test case, per the truth table. Or
 - ii. Otherwise identical test devices which are pre-configured for the receiver-antenna selections per the truth table.
 - c. The device is allowed to change the receiver-antenna combination that it uses at different RF frequencies within the same band, or when different TX power levels are chosen, or when a different air interface is chosen, or other manufacturer declared conditions, as long as this is clearly indicated in the truth table.

6.20 LTE Category M1

6.20.1 Test Procedure

Receiver sensitivity measurements shall be performed using data throughput as the measurement metric. The EUT's receiver sensitivity corresponds to the minimum downlink signal power required to provide a data throughput rate greater than or equal to 95% of the maximum throughput of the reference measurement channel. Refer to [Appendix A](#) for set-up illustrations.

The LTE system simulator and EUT shall be configured per section 7.3EA (Reference Sensitivity Level for UE Category M1) of 3GPP TS 36.521-1 using the defaults specified in 3GPP TS 36.521-1 and 3GPP TS 36.508 as applicable. For a given downlink RF power level, throughput shall be measured using the test procedure in section 7.3EA of 3GPP TS 36.521-1 using the downlink and uplink reference measurement channels defined in Tables A.2.2.1.1-1b, A.2.3.1.1-1b, A.3.2-1b, and A.3.2-2b of 3GPP TS 36.521-1 and [Table 6-31](#).

For the mid channel and high channel test points, the system simulator shall send two-sided dynamic OCNG Pattern OP.2 FDD/TDD for the DL signal as described in Annex A.5.1.2/A.5.2.2 of 3GPP TS 36.521-1. For the low channel test points for bands with a 10 MHz and 20 MHz macro channel bandwidth, the system simulator shall send two-sided dynamic OCNG Pattern OP.2 FDD/TDD for the DL signal as described in Annex A.5.1.2/A.5.2.2 of 3GPP TS 36.521-1.

For the low channel test points for bands with a 5 MHz macro channel bandwidth, the system simulator shall send one sided dynamic OCNG Pattern OP.1 FDD/TDD for the DL signal as described in Annex A.5.1.1/A.5.2.1. The LTE system simulator shall send continuous uplink power control “up” commands to the EUT to ensure the EUT’s transmitter is at maximum output power during the sensitivity searches. The downlink power step size shall be no more than 0.5 dB when the RF power level is near the LTE sensitivity level. The minimum RF power level resulting in a data throughput rate greater than or equal to 95% of the maximum throughput of the reference measurement channel shall be recorded as the downlink power level corresponding to the 95% throughput percentage (the data throughput rate is as defined in section 7.3EA of 3GPP TS 36.521-1). As OCNG is used to fill the entire channel bandwidth with the same PSD at the minimum RF power level resulting in a data throughput rate greater than or equal to 95% of the maximum throughput of the reference measurement, TIS for LTE Category M1 shall be calculated based on the 6 RBs that compose the LTE Category M1 narrowband index. This is equivalent to the definition of REFSSENS in 3GPP TS 36.521-1 section 7.3EA.5. Care must be taken to ensure that the duration of the throughput measurement is sufficient to achieve statistical significance according to Annex G.2 of 3GPP TS 36.521-1. The downlink signal level for each EUT test condition shall be recorded for integration pursuant to [Appendix B.3](#) to give a single figure of merit referred to as Total Isotropic Sensitivity (TIS).

Typically, the maximum deviation in receive level measurements from peak to null of any one channel does not exceed 30 dB. Therefore, the test facility may elect to initiate each sensitivity measurement starting with the base station power set 30 dB above the lowest sensitivity level measured in order to reduce the time required to search for the sensitivity floor. For points where this setting is below the target sensitivity level, the sensitivity may be considered negligible for that location and the initial value used in place of an actual measurement.

TIS shall be fully measured as described above and calculated pursuant to [Appendix B.3](#). TIS measurements shall be carried out for different frequency pairs (FDD, HD-FDD; UL -uplink /DL -downlink) or frequencies (TDD) and RB allocations across the bands supported by the EUT, as defined in [Table 6-31](#). TIS results shall be based on total downlink channel power within the narrowband index (6 RBs) and shall be reported as dBm/1080 kHz.

TABLE 6-31 LTE CATEGORY M1 TIS MEASUREMENTS TABLE FOR THE PRIMARY MECHANICAL MODE¹

Band	Channel Bandwidth (MHz)	Channel	Frequency (MHz) [center of DL RB allocation]	UL RB Allocation	DL RB Allocation
2	10	650	1931.04	6 RB with RBstart=43	4 RB with RBstart=1
	10	900	1961.44	6 RB with RBstart=43	4 RB with RBstart=31
	10	1150	1988.6	6 RB with RBstart=43	4 RB with RBstart=43
4	10	2000	2111.04	6 RB with RBstart=43	4 RB with RBstart=1
	10	2175	2133.94	6 RB with RBstart=43	4 RB with RBstart=31
	10	2350	2153.6	6 RB with RBstart=43	4 RB with RBstart=43

TABLE 6-31 LTE CATEGORY M1 TIS MEASUREMENTS TABLE FOR THE PRIMARY MECHANICAL MODE¹

Band	Channel Bandwidth (MHz)	Channel	Frequency (MHz) [center of DL RB allocation]	UL RB Allocation	DL RB Allocation
5 ²	10	2450	870.04	6 RB with RBstart=43	4 RB with RBstart=1
	10	2525	882.94	6 RB with RBstart=43	4 RB with RBstart=31
	10	2600	892.6	6 RB with RBstart=43	4 RB with RBstart=43
7	20	2850	2621.72	6 RB with RBstart=92	4 RB with RBstart=2
	20	3100	2656.44	6 RB with RBstart=92	4 RB with RBstart=56
	20	3350	2687.92	6 RB with RBstart=92	4 RB with RBstart=92
12	5	5035	729.61	6 RB with RBstart=19	4 RB with RBstart=0
	5	5095	739.03	6 RB with RBstart=19	4 RB with RBstart=19
	5	5155	745.03	6 RB with RBstart=19	4 RB with RBstart=19
13	10	5230	747.04	6 RB with RBstart=1	4 RB with RBstart=1
	10	5230	752.44	6 RB with RBstart=1	4 RB with RBstart=31
	10	5230	754.6	6 RB with RBstart=1	4 RB with RBstart=43
26 ²	5	8715	859.61	6 RB with RBstart=19	4 RB with RBstart=0
	5	8865	878.03	6 RB with RBstart=19	4 RB with RBstart=19
	5	9015	893.03	6 RB with RBstart=19	4 RB with RBstart=19
41	20	39750	2497.72	6 RB with RBstart=92	4 RB with RBstart=2
	20	40620	2594.44	6 RB with RBstart=92	4 RB with RBstart=56
	20	41490	2687.92	6 RB with RBstart=92	4 RB with RBstart=92
71	10	68636	618.04	6 RB with RBstart=43	4 RB with RBstart=1
	10	68761	635.94	6 RB with RBstart=43	4 RB with RBstart=31
	10	68886	650.6	6 RB with RBstart=43	4 RB with RBstart=43
Note 1: Primary Mechanical Mode refers to device configured in preferred mode per manufacturer instructions (typically means antenna extended, fold or portrait slide open, but depends on form factor).					
Note 2: If the device supports Band 26 and Band 5, then testing is only required to be completed in Band 26.					

Forearm and/or free-space testing shall be conducted based on device type, as specified in [Appendix O](#). Refer to [Appendix Q](#) for forearm testing requirements. Perform each test on all specified frequencies with the EUT antenna extended and retracted, as applicable.

Intermediate channel measurements are not currently defined for LTE Category M1 devices.

6.20.2 Criteria

Results shall be reported as specified in [Appendix B](#) using the figures of merit given in [Appendix B.3](#). [Appendix B.1](#) contains the pass/fail OTA tables for LTE Category M1. Pass/fail criteria for LTE Category M1 is for future study, and different pass/fail criteria may be developed for different device types/use cases. Reports shall include results for applicable use cases, including free-space and/or wrist-worn configurations across all channels and RB allocations measured with the EUT in primary mechanical mode, and (if applicable) in non-primary mechanical modes as reference information.

TABLE 6-32 LTE CAT-M1 MAXIMUM C-TIS LEVEL (IN dBm/1080 KHz) REQUIREMENTS FOR THE PRIMARY MECHANICAL MODE¹

Band	Worn on Wrist?	FS	WL and WR
LTE Band 71	Yes	N/A	TBD
	No	TBD	N/A
LTE Band 12	Yes	N/A	TBD
	No	TBD	N/A
LTE Band 13	Yes	N/A	TBD
	No	TBD	N/A
LTE Band 26	Yes	N/A	TBD
	No	TBD	N/A
LTE Band 5	Yes	N/A	TBD
	No	TBD	N/A
LTE Band 4	Yes	N/A	TBD
	No	TBD	N/A
LTE Band 2	Yes	N/A	TBD
	No	TBD	N/A
LTE Band 7	Yes	N/A	TBD
	No	TBD	N/A
LTE Band 41	Yes	N/A	TBD
	No	TBD	N/A

Note 1: Primary Mechanical Mode refers to device configured in preferred mode per manufacturer instructions (typically means antenna extended, fold or portrait slide open, but depends on form factor).

6.21 LTE LAA Downlink Carrier Aggregation

6.21.1 Test Procedure

This procedure only applies to LAA downlink carrier aggregation with a single licensed uplink carrier on the PCC. This procedure measures TIS for Band 46 in LAA downlink carrier aggregation combinations with 2 component carriers (i.e. one licensed PCC with one Band 46 un-licensed SCC) and 3 component carriers (i.e. one licensed PCC with one licensed SCC and one Band 46 un-licensed SCC). Therefore, LAA CA testing as described in this section provides an assessment of radiated sensitivity on the Band 46 CC with the EUT operating in the LAA CA mode. An LAA CA mode is defined as a specific combination of licensed and Band 46 un-licensed bands assigned to the PCC and SCCs used in carrier aggregation. The LAA CA test methodology described in this section is not intended to provide a measurement of the EUT's aggregate throughput during LAA CA operation.

This procedure assumes the following:

- The tuning of the Band 46 antenna does not change between different LAA CA modes.

- The measurement of TRP and TIS on licensed carrier(s) within an LAA CA mode can be covered by standalone testing (one licensed carrier) and CA testing (two or more licensed carriers). That is, antenna tuning of the licensed carriers is independent of the antenna tuning for Band 46.

LAA CA sensitivity measurements on Band 46 shall be performed using data throughput on only the Band 46 CC as the measurement metric. The EUT's LAA CA Band 46 receiver sensitivity corresponds to the minimum downlink signal power required to provide a data throughput rate greater than or equal to 95% of the maximum throughput of the reference measurement channel on the tested Band 46 CC. Refer to [Appendix A](#) for set-up illustrations.

Band 46 TIS shall be fully measured for one supported LAA CA combination with 2 CC's from [Table 6-33](#) per [Appendix O.8.2](#). For all other LAA CA combinations in [Table 6-33](#) and [Table 6-34](#) that require testing, Band 46 EIS performance shall be evaluated using the LAA Un-Licensed Degradation (LUD) test.

TABLE 6-33 LTE LAA CARRIER AGGREGATION MODE (2 TOTAL DOWNLINK CARRIERS WITH 1 LICENSED CARRIER, 1 UPLINK CARRIER) TIS MEASUREMENTS TABLE FOR THE PRIMARY MECHANICAL MODE¹

Carrier Aggregation Combination	Primary Component Carrier (PCC) Band	Secondary Component Carrier (SCC) Band	PCC BW (MHz)	SCC BW (MHz)	PCC Channel	SCC Channel	PCC UL RB Allocation	PCC DL RB Allocation	SCC DL RB Allocation
CA_2A-46A	2	46	10	20	650	46890	50 RB with RBstart=0	50 RB with RBstart=0	100 RB with RBstart=0
					900	50665	50 RB with RBstart=0	50 RB with RBstart=0	100 RB with RBstart=0
					1150	54440	50 RB with RBstart=0	50 RB with RBstart=0	100 RB with RBstart=0
CA_4A-46A ²	4	46	10	20	2000	46890	50 RB with RBstart=0	50 RB with RBstart=0	100 RB with RBstart=0
					2175	50665	50 RB with RBstart=0	50 RB with RBstart=0	100 RB with RBstart=0
					2350	54440	50 RB with RBstart=0	50 RB with RBstart=0	100 RB with RBstart=0
CA_5A-46A	5	46	10	20	2450	46890	25 RB with RBstart=25	50 RB with RBstart=0	100 RB with RBstart=0
					2525	50665	25 RB with RBstart=25	50 RB with RBstart=0	100 RB with RBstart=0
					2600	54440	25 RB with RBstart=25	50 RB with RBstart=0	100 RB with RBstart=0
CA_12A-46A	12	46	5	20	5035	46890	20 RB with RBstart=5	25 RB with RBstart=0	100 RB with RBstart=0
					5095	50665	20 RB with RBstart=5	25 RB with RBstart=0	100 RB with RBstart=0
					5155	54440	20 RB with RBstart=5	25 RB with RBstart=0	100 RB with RBstart=0

TABLE 6-33 LTE LAA CARRIER AGGREGATION MODE (2 TOTAL DOWNLINK CARRIERS WITH 1 LICENSED CARRIER, 1 UPLINK CARRIER) TIS MEASUREMENTS TABLE FOR THE PRIMARY MECHANICAL MODE¹

Carrier Aggregation Combination	Primary Component Carrier (PCC) Band	Secondary Component Carrier (SCC) Band	PCC BW (MHz)	SCC BW (MHz)	PCC Channel	SCC Channel	PCC UL RB Allocation	PCC DL RB Allocation	SCC DL RB Allocation
CA_13A-46A	13	46	10	20	5230	46890	15 RB with RBstart=0	50 RB with RBstart=0	100 RB with RBstart=0
					5230	50665	15 RB with RBstart=0	50 RB with RBstart=0	100 RB with RBstart=0
					5230	54440	15 RB with RBstart=0	50 RB with RBstart=0	100 RB with RBstart=0
CA_25A-46A	25	46	5	20	8065	46890	25 RB with RBstart=0	25 RB with RBstart=0	100 RB with RBstart=0
					8365	50665	25 RB with RBstart=0	25 RB with RBstart=0	100 RB with RBstart=0
					8665	54440	25 RB with RBstart=0	25 RB with RBstart=0	100 RB with RBstart=0
CA_26A-46A	26	46	5	20	8715	46890	25 RB with RBstart=0	25 RB with RBstart=0	100 RB with RBstart=0
					8865	50665	25 RB with RBstart=0	25 RB with RBstart=0	100 RB with RBstart=0
					9015	54440	25 RB with RBstart=0	25 RB with RBstart=0	100 RB with RBstart=0
CA_30A-46A	30	46	10	20	9820	46890	25 RB with RBstart=25	50 RB with RBstart=0	100 RB with RBstart=0
					9820	50665	25 RB with RBstart=25	50 RB with RBstart=0	100 RB with RBstart=0
					9820	54440	25 RB with RBstart=25	50 RB with RBstart=0	100 RB with RBstart=0
CA_41A-46A	41	46	20	20	39750	46890	100 RB with RBstart=0	100 RB with RBstart=0	100 RB with RBstart=0
					40620	50665	100 RB with RBstart=0	100 RB with RBstart=0	100 RB with RBstart=0
					41490	54440	100 RB with RBstart=0	100 RB with RBstart=0	100 RB with RBstart=0
CA_66A-46A ²	66	46	10	20	66486	46890	50 RB with RBstart=0	50 RB with RBstart=0	100 RB with RBstart=0
					66786	50665	50 RB with RBstart=0	50 RB with RBstart=0	100 RB with RBstart=0
					67086	54440	50 RB with RBstart=0	50 RB with RBstart=0	100 RB with RBstart=0

Note 1: Primary Mechanical Mode refers to device configured in preferred mode per manufacturer instructions (typically means antenna extended, fold or portrait slide open, but depends on form factor).

Note 2: If the device supports both CA_4A-46A and CA_66A-46A, then testing is only required in CA_66A-46A.

TABLE 6-34 LTE LAA CARRIER AGGREGATION MODE (3 TOTAL DOWNLINK CARRIERS WITH 2 LICENSED CARRIERS, 1 UPLINK CARRIER) TIS MEASUREMENTS TABLE FOR THE PRIMARY MECHANICAL MODE¹

Carrier Aggregation Combination	Primary Component Carrier (PCC) Band	Secondary Component Carriers (SCC1/ SCC2) Bands	PCC BW (MHz)	SCC BWs (MHz)	PCC Channel	SCC Channels	PCC UL RB Allocation	PCC DL RB Allocation	SCC1 DL RB Allocation	SCC2 DL RB Allocation
CA_2A-4A-46A ²	2	SCC1=4 SCC2=46	10	SCC1=10 SCC2=20	650	SCC1=2000	50 RB with RBstart=0	50 RB with RBstart=0	50 RB with RBstart=0	100 RB with RBstart=0
						SCC2=46890				
					900	SCC1=2175	50 RB with RBstart=0	50 RB with RBstart=0	50 RB with RBstart=0	100 RB with RBstart=0
						SCC2=50665				
					1150	SCC1=2350	50 RB with RBstart=0	50 RB with RBstart=0	50 RB with RBstart=0	100 RB with RBstart=0
						SCC2=54440				
CA_2A-5A-46A	2	SCC1=5 SCC2=46	10	SCC1=10 SCC2=20	650	SCC1=2450	50 RB with RBstart=0	50 RB with RBstart=0	50 RB with RBstart=0	100 RB with RBstart=0
						SCC2=46890				
					900	SCC1=2525	50 RB with RBstart=0	50 RB with RBstart=0	50 RB with RBstart=0	100 RB with RBstart=0
						SCC2=50665				
					1150	SCC1=2600	50 RB with RBstart=0	50 RB with RBstart=0	50 RB with RBstart=0	100 RB with RBstart=0
						SCC2=54440				
CA_2A-12A-46A	2	SCC1=12 SCC2=46	10	SCC1=5 SCC2=20	650	SCC1=5035	50 RB with RBstart=0	50 RB with RBstart=0	25 RB with RBstart=0	100 RB with RBstart=0
						SCC2=46890				
					900	SCC1=5095	50 RB with RBstart=0	50 RB with RBstart=0	25 RB with RBstart=0	100 RB with RBstart=0
						SCC2=50665				
					1150	SCC1=5155	50 RB with RBstart=0	50 RB with RBstart=0	25 RB with RBstart=0	100 RB with RBstart=0
						SCC2=54440				
CA_2A-13A-46A	2	SCC1=13 SCC2=46	10	SCC1=10 SCC2=20	650	SCC1=5230	50 RB with RBstart=0	50 RB with RBstart=0	50 RB with RBstart=0	100 RB with RBstart=0
						SCC2=46890				
					900	SCC1=5230	50 RB with RBstart=0	50 RB with RBstart=0	50 RB with RBstart=0	100 RB with RBstart=0
						SCC2=50665				
					1150	SCC1=5230	50 RB with RBstart=0	50 RB with RBstart=0	50 RB with RBstart=0	100 RB with RBstart=0
						SCC2=54440				

TABLE 6-34 LTE LAA CARRIER AGGREGATION MODE (3 TOTAL DOWNLINK CARRIERS WITH 2 LICENSED CARRIERS, 1 UPLINK CARRIER) TIS MEASUREMENTS TABLE FOR THE PRIMARY MECHANICAL MODE¹

Carrier Aggregation Combination	Primary Component Carrier (PCC) Band	Secondary Component Carriers (SCC1/ SCC2) Bands	PCC BW (MHz)	SCC BWs (MHz)	PCC Channel	SCC Channels	PCC UL RB Allocation	PCC DL RB Allocation	SCC1 DL RB Allocation	SCC2 DL RB Allocation
CA_2A-29A-46A	2	SCC1=29 SCC2=46	10	SCC1=10 SCC2=20	650	SCC1=9720	50 RB with RBstart=0	50 RB with RBstart=0	50 RB with RBstart=0	100 RB with RBstart=0
						SCC2=46890				
					900	SCC1=9720	50 RB with RBstart=0	50 RB with RBstart=0	50 RB with RBstart=0	100 RB with RBstart=0
						SCC2=50665				
					1150	SCC1=9720	50 RB with RBstart=0	50 RB with RBstart=0	50 RB with RBstart=0	100 RB with RBstart=0
						SCC2=54440				
CA_2A-66A-46A ²	2	SCC1=66 SCC2=46	10	SCC1=10 SCC2=20	650	SCC1=66486	50 RB with RBstart=0	50 RB with RBstart=0	50 RB with RBstart=0	100 RB with RBstart=0
						SCC2=46890				
					900	SCC1=66786	50 RB with RBstart=0	50 RB with RBstart=0	50 RB with RBstart=0	100 RB with RBstart=0
						SCC2=50665				
					1150	SCC1=67286	50 RB with RBstart=0	50 RB with RBstart=0	50 RB with RBstart=0	100 RB with RBstart=0
						SCC2=54440				
CA_4A-5A-46A ²	4	SCC1=5 SCC2=46	10	SCC1=10 SCC2=20	2000	SCC1=2450	50 RB with RBstart=0	50 RB with RBstart=0	50 RB with RBstart=0	100 RB with RBstart=0
						SCC2=46890				
					2175	SCC1=2525	50 RB with RBstart=0	50 RB with RBstart=0	50 RB with RBstart=0	100 RB with RBstart=0
						SCC2=50665				
					2350	SCC1=2600	50 RB with RBstart=0	50 RB with RBstart=0	50 RB with RBstart=0	100 RB with RBstart=0
						SCC2=54440				
CA_4A-12A-46A ²	4	SCC1=12 SCC2=46	10	SCC1=5 SCC2=20	2000	SCC1=5035	50 RB with RBstart=0	50 RB with RBstart=0	25 RB with RBstart=0	100 RB with RBstart=0
						SCC2=46890				
					2175	SCC1=5095	50 RB with RBstart=0	50 RB with RBstart=0	25 RB with RBstart=0	100 RB with RBstart=0
						SCC2=50665				
					2350	SCC1=5155	50 RB with RBstart=0	50 RB with RBstart=0	25 RB with RBstart=0	100 RB with RBstart=0
						SCC2=54440				
CA_4A-13A-46A ²	4	SCC1=13 SCC2=46	10	SCC1=10 SCC2=20	2000	SCC1=5230	50 RB with RBstart=0	50 RB with RBstart=0	50 RB with RBstart=0	100 RB with RBstart=0
						SCC2=46890				
					2175	SCC1=5230	50 RB with RBstart=0	50 RB with RBstart=0	50 RB with RBstart=0	100 RB with RBstart=0
						SCC2=50665				
					2350	SCC1=5230	50 RB with RBstart=0	50 RB with RBstart=0	50 RB with RBstart=0	100 RB with RBstart=0
						SCC2=54440				

TABLE 6-34 LTE LAA CARRIER AGGREGATION MODE (3 TOTAL DOWNLINK CARRIERS WITH 2 LICENSED CARRIERS, 1 UPLINK CARRIER) TIS MEASUREMENTS TABLE FOR THE PRIMARY MECHANICAL MODE¹

Carrier Aggregation Combination	Primary Component Carrier (PCC) Band	Secondary Component Carriers (SCC1/ SCC2) Bands	PCC BW (MHz)	SCC BWs (MHz)	PCC Channel	SCC Channels	PCC UL RB Allocation	PCC DL RB Allocation	SCC1 DL RB Allocation	SCC2 DL RB Allocation
CA_5A-12A-46A	5	SCC1=12 SCC2=46	10	SCC1=5 SCC2=20	2450	SCC1=5035	25 RB with RBstart=25	50 RB with RBstart=0	25 RB with RBstart=0	100 RB with RBstart=0
						SCC2=46890				
					2525	SCC1=5095	25 RB with RBstart=25	50 RB with RBstart=0	25 RB with RBstart=0	100 RB with RBstart=0
						SCC2=50665				
					2600	SCC1=5155	25 RB with RBstart=25	50 RB with RBstart=0	25 RB with RBstart=0	100 RB with RBstart=0
						SCC2=54440				
CA_30A-12A-46A	30	SCC1=12 SCC2=46	10	SCC1=5 SCC2=20	9820	SCC1=5035	25 RB with RBstart=25	50 RB with RBstart=0	25 RB with RBstart=0	100 RB with RBstart=0
						SCC2=46890				
					9820	SCC1=5095	25 RB with RBstart=25	50 RB with RBstart=0	25 RB with RBstart=0	100 RB with RBstart=0
						SCC2=50665				
					9820	SCC1=5155	25 RB with RBstart=25	50 RB with RBstart=0	25 RB with RBstart=0	100 RB with RBstart=0
						SCC2=54440				
CA_41C-46A	41	SCC1=41 SCC2=46	20	SCC1=20 SCC2=20	39750	SCC1=39948	100 RB with RBstart=0	100 RB with RBstart=0	100 RB with RBstart=0	100 RB with RBstart=0
						SCC2=46890				
					40620	SCC1=40422	100 RB with RBstart=0	100 RB with RBstart=0	100 RB with RBstart=0	100 RB with RBstart=0
						SCC2=50665				
					41490	SCC1=41292	100 RB with RBstart=0	100 RB with RBstart=0	100 RB with RBstart=0	100 RB with RBstart=0
						SCC2=54440				
CA_66A-5A-46A ²	66	SCC1=5 SCC2=46	10	SCC1=10 SCC2=20	66486	SCC1=2450	50 RB with RBstart=0	50 RB with RBstart=0	50 RB with RBstart=0	100 RB with RBstart=0
						SCC2=46890				
					66786	SCC1=2525	50 RB with RBstart=0	50 RB with RBstart=0	50 RB with RBstart=0	100 RB with RBstart=0
						SCC2=50665				
					67086	SCC1=2600	50 RB with RBstart=0	50 RB with RBstart=0	50 RB with RBstart=0	100 RB with RBstart=0
						SCC2=54440				
CA_66A-12A-46A ²	66	SCC1=12 SCC2=46	10	SCC1=5 SCC2=20	66486	SCC1=5035	50 RB with RBstart=0	50 RB with RBstart=0	25 RB with RBstart=0	100 RB with RBstart=0
						SCC2=46890				
					66786	SCC1=5095	50 RB with RBstart=0	50 RB with RBstart=0	25 RB with RBstart=0	100 RB with RBstart=0
						SCC2=50665				
					67086	SCC1=5155	50 RB with RBstart=0	50 RB with RBstart=0	25 RB with RBstart=0	100 RB with RBstart=0
						SCC2=54440				

TABLE 6-34 LTE LAA CARRIER AGGREGATION MODE (3 TOTAL DOWNLINK CARRIERS WITH 2 LICENSED CARRIERS, 1 UPLINK CARRIER) TIS MEASUREMENTS TABLE FOR THE PRIMARY MECHANICAL MODE¹

Carrier Aggregation Combination	Primary Component Carrier (PCC) Band	Secondary Component Carriers (SCC1/ SCC2) Bands	PCC BW (MHz)	SCC BWs (MHz)	PCC Channel	SCC Channels	PCC UL RB Allocation	PCC DL RB Allocation	SCC1 DL RB Allocation	SCC2 DL RB Allocation
CA_66A-13A-46A ²	66	SCC1=13 SCC2=46	10	SCC1=10 SCC2=20	66486	SCC1=5230	50 RB with RBstart=0	50 RB with RBstart=0	50 RB with RBstart=0	100 RB with RBstart=0
						SCC2=46890				
					66786	SCC1=5230	50 RB with RBstart=0	50 RB with RBstart=0	50 RB with RBstart=0	100 RB with RBstart=0
						SCC2=50665				
					67086	SCC1=5230	50 RB with RBstart=0	50 RB with RBstart=0	50 RB with RBstart=0	100 RB with RBstart=0
						SCC2=54440				
CA_66A-66A-46A	66	SCC1=66 SCC2=46	10	SCC1=10 SCC2=20	66486	SCC1=67286	50 RB with RBstart=0	50 RB with RBstart=0	50 RB with RBstart=0	100 RB with RBstart=0
						SCC2=46890				
					66786	SCC1=66486	50 RB with RBstart=0	50 RB with RBstart=0	50 RB with RBstart=0	100 RB with RBstart=0
						SCC2=50665				
					67086	SCC1=66786	50 RB with RBstart=0	50 RB with RBstart=0	50 RB with RBstart=0	100 RB with RBstart=0
						SCC2=54440				

Note 1: Primary Mechanical Mode refers to device configured in preferred mode per manufacturer instructions (typically means antenna extended, fold or portrait slide open, but depends on form factor).

Note 2: If the device supports both CA_4A-xA-46A and CA_66A-xA-46A (where x is the band number of a licensed band SCC), then testing is only required in CA_66A-xA-46A. Similarly, if the device supports both CA_xA-4A-46A and CA_xA-66A-46A (where x is the band number of the licensed PCC), then testing is only required in CA_xA-66A-46A.

Full Band 46 TIS Test:

To remain consistent with 3GPP core specifications, the LTE system simulator and EUT shall be configured per 3GPP 36.521-1, section 7.3A.3 (Reference Sensitivity Level for CA (inter-band DL CA without UL CA)). In each case, the defaults specified in 3GPP TS 36.521-1 and 3GPP TS 36.508 shall be used as applicable,

For a given downlink RF power level, throughput shall be measured using the test procedure in section 7.3 of 3GPP TS 36.521-1 using the downlink and uplink reference measurement channels defined in Annexes A.2.2, A.2.3, and A.3.2 of 3GPP TS 36.521-1 and Table 6-33 and Table 6-34. For LTE Band 13, the settings in Table 6-7 shall take precedence over the settings in Annexes A.2.2, A.2.3, and A.3.2 of 3GPP TS 36.521-1.

The LTE system simulator shall send continuous uplink power control “up” commands to the EUT to ensure the EUT’s transmitter is operating at maximum output power during the sensitivity searches of the the Band 46 SCC. As the 3GPP reference does not make any mention of p-Max, nor is p-Max included in the default message content defined in 3GPP TS 36.508, p-Max shall not be signaled during attach procedures or during measurements.

When testing the Band 46 SCC, the PCC is used only to provide control of the EUT, and therefore a calibrated downlink power level to the EUT is not required. Labs may assign any desired antenna to provide support for the untested PCC so long as the selected antenna does not interfere with the tested Band 46 SCC measurements. Labs are encouraged to confirm that the eNodeB's PCC output power and antenna placement is sufficient to maintain a reliable radio link to the EUT in advance of beginning the execution of a LAA CA TIS test on the Band 46 SCC. The DL of the untested CC(s) should be configured to not impair the tested Band 46 SCC.

The downlink power step size of the Band 46 SCC under test shall be no more than 0.5 dB when the RF power level is near the LTE sensitivity level. The minimum RF power level resulting in a data throughput rate greater than or equal to 95% of the maximum throughput of the reference measurement channel shall be recorded as the downlink power level corresponding to the 95% throughput percentage (the data throughput rate is as defined in section 7.3A.3 of 3GPP TS 36.521-1 as applicable). Care must be taken to ensure that the duration of the throughput measurement is sufficient to achieve statistical significance according to Annex G.2 of 3GPP TS 36.521-1. The downlink signal level for each EUT test condition shall be recorded for integration pursuant to [Appendix B.3](#) to give a single figure of merit referred to as Total Isotropic Sensitivity (TIS).

Typically, the maximum deviation in receive level measurements from peak to null of any one channel does not exceed 30 dB. Therefore, the test facility may elect to initiate each sensitivity measurement starting with the base station power set 30 dB above the lowest sensitivity level measured in order to reduce the time required to search for the sensitivity floor. For points where this setting is below the target sensitivity level, the sensitivity may be considered negligible for that location and the initial value used in place of an actual measurement. TIS for the Band 46 SCC shall be fully measured as described above and calculated pursuant to [Appendix B.3](#).

There is no test for relative sensitivity on intermediate channels. This is a topic for future study.

Hand phantom only and/or free-space testing shall be conducted based on device type, as specified in [Appendix O](#). Refer to [Appendix C](#) for hand testing requirements. Perform each test on all supported CA modes defined in [Table 6-33](#) and [Table 6-34](#) according to the use cases associated with each band as specified in [Table 6-33](#) and [Table 6-34](#) with the EUT antenna extended and retracted, as applicable.

Note: *Head-adjacent testing is not required for LTE LAA CA.*

Note: *EUTs incapable of supporting the aggregated channel BW associated the LAA CA modes specified in [Table 6-33](#) and [Table 6-34](#) do not need to be tested.*

LAA Un-Licensed Degradation (LUD) Test:

For the LAA un-licensed degradation test, the Band 46 reference TIS is defined as follows:

- For FS TIS_{ref}, -83 dBm, assuming the -90 dBm conducted REFSSENS value in 3GPP TS 36.101 and an antenna efficiency of -7 dB.
- For HR/HL TIS_{ref}, -80 dBm, assuming the -90 dBm conducted REFSSENS value in 3GPP TS 36.101 and an antenna efficiency of -10 dB.

Procedure for evaluating Band 46 radiated sensitivity using the LAA un-licensed degradation test for a given LAA CA combination:

1. Move the EUT and chamber positioner(s) to the location & polarization resulting in the best-radiated free-space sensitivity measured for the full Band 46 TIS test for the low Band 46 test frequency, now used as a Reference Channel. Set the PCC to the corresponding channel settings in [Table 6-33](#) and [Table 6-34](#) for the case where the Band 46 SCC is set to the low Band 46 test frequency for the LAA CA combination under test.
2. Note the downlink power level which corresponds to the EUT's peak free-space radiated sensitivity as described in Step 1 above, which will be referred to as FS EIS_(peak ref low). Next, determine the margin, M1_{low}, in dB, between the EUT's measured TIS (for the full Band 46 TIS test) and the corresponding FS TIS_{ref}. If the device doesn't meet the FS TIS_{ref} (for the full

Band 46 TIS test), then set $M1_{low}=0$. Adjust the digital call simulator to the RF power level calculated by the following formula:

EQUATION 6.27

$$\text{FS Downlink Signal Power}_{low} \text{ (dBm)} = \text{FS EIS}_{(\text{peak ref low})} \text{ (dBm)} + M1_{low} \text{ (dB)} + 3 \text{ (dB)}$$

For example, if the EUT's FS EIS_(peak ref low) was -106 dBm on the reference channel and the FS TIS (for the full Band 46 TIS test on the reference channel) was -85 dBm, we have:

$$(-106 \text{ (dBm)} + 2 \text{ (dB)} + 3 \text{ (dB)}) \text{ dBm} = -101 \text{ dBm}$$

In this example, the signal generator would be set to -101 dBm for the low test channel for all LAA CA combinations in [Table 6-33](#) and [Table 6-34](#) that are tested in free space using the LAA Un-Licensed Degradation Test.

3. Throughput of the EUT shall be measured using the test procedure in section 7.3A.3 of 3GPP TS 36.521-1 using the downlink and uplink reference measurement channels defined in Annexes A.2.2, A.2.3, and A.3.2 of 3GPP TS 36.521-1 and [Table 6-33](#) and [Table 6-34](#) of this document (the data throughput rate is as defined in section 7.3A.3 of 3GPP TS 36.521-1). For LTE Band 13, the settings in [Table 6-7](#) shall take precedence over the settings in Annexes A.2.2, A.2.3, and A.3.2 of 3GPP TS 36.521-1. The LTE system simulator shall send continuous uplink power control “up” commands to the EUT to ensure the EUT's transmitter is at maximum output power. The measured throughput rate shall be greater than or equal to 95% of the maximum throughput of the reference measurement channel. Care must be taken to ensure that the duration of the throughput measurement is sufficient to achieve statistical significance according to Annex G.2 of 3GPP TS 36.521-1. If the throughput test fails, increase FS Downlink Signal Power low in 1 dB steps until the throughput test passes.
4. Repeat steps 1 through 3 of this procedure for the mid and high test channels per [Table 6-33](#) and [Table 6-34](#).
5. Report the free-space pass/fail status of each test channel for the LAA CA combination under test. For test channels which failed, report the value of FS Downlink Signal Power required to pass the test. Free-space testing shall be conducted based on device type, as specified in [Appendix O](#). Perform each test on all specified frequencies with the EUT antenna extended and retracted, as applicable.
6. If the device must be tested in the HR and HL positions, then move the EUT and chamber positioner(s) to the location & polarization resulting in the best-radiated HR sensitivity measured for the full Band 46 TIS test for the low Band 46 test frequency, now used as a Reference Channel. Set the PCC to the corresponding channel settings in [Table 6-33](#) and [Table 6-34](#) for the case where the Band 46 SCC is set to the low Band 46 test frequency for the LAA CA combination under test.
7. Note the downlink power level which corresponds to the EUT's peak HR radiated sensitivity as described in Step 6 above, which will be referred to as HR EIS_(peak ref low). Next, determine the margin, $M1_{low}$, in dB, between the EUT's measured TIS (for the full Band 46 TIS test) and the corresponding HR TIS_{ref}. If the device doesn't meet the HR TIS_{ref} (for the full Band 46 TIS test), then set $M1_{low}=0$. Adjust the digital call simulator to the RF power level calculated by the following formula:

EQUATION 6.28

$$\text{HR Downlink Signal Power}_{low} \text{ (dBm)} = \text{HR EIS}_{(\text{peak ref low})} \text{ (dBm)} + M1_{low} \text{ (dB)} + 3 \text{ (dB)}$$

For example, if the EUT's HR EIS_(peak ref low) was -98 dBm on the reference channel and the HR TIS (for the full Band 46 TIS test on the reference channel) was -82 dBm, we have:

$$(-98 \text{ (dBm)} + 2 \text{ (dB)} + 3 \text{ (dB)}) \text{ dBm} = -93 \text{ dBm}$$

In this example, the signal generator would be set to -93 dBm for the low channel for all LAA CA combinations in [Table 6-33](#) and [Table 6-34](#) that are tested with HR using the LAA Un-Licensed Degradation Test.

8. Throughput of the EUT shall be measured using the test procedure in section 7.3A.3 of 3GPP TS 36.521-1 using the downlink and uplink reference measurement channels defined in Annexes A.2.2, A.2.3, and A.3.2 of 3GPP TS 36.521-1 and [Table 6-33](#) and [Table 6-34](#) of this document (the data throughput rate is as defined in section 7.3A.3 of 3GPP TS 36.521-1). For LTE Band 13, the settings in [Table 6-7](#) shall take precedence over the settings in Annexes A.2.2, A.2.3, and A.3.2 of 3GPP TS 36.521-1. The LTE system simulator shall send continuous uplink power control “up” commands to the EUT to ensure the EUT’s transmitter is at maximum output power. The measured throughput rate shall be greater than or equal to 95% of the maximum throughput of the reference measurement channel. Care must be taken to ensure that the duration of the throughput measurement is sufficient to achieve statistical significance according to Annex G.2 of 3GPP TS 36.521-1. If the throughput test fails, increase HR Downlink Signal Power low in 1 dB steps until the throughput test passes.
9. Repeat steps 1 through 3 of this procedure for the mid and high test channels per [Table 6-33](#) and [Table 6-34](#)
10. Report the HR pass/fail status of each test channel for the LAA CA combination under test. For test channels which failed, report the value of HR Downlink Signal Power required to pass the test. HR testing shall be conducted based on device type, as specified in [Appendix O](#). Perform each test on all specified frequencies with the EUT antenna extended and retracted, as applicable.
11. Repeat steps 6 through 10 for the HL position.
12. Repeat steps 1 through 11 for all LAA CA combinations where Band 46 sensitivity will be evaluated using the LAA Un-Licensed Degradation Test.

For the LAA un-licensed degradation test, hand phantom only and/or free-space testing shall be conducted based on device type, as specified in [Appendix O](#). Refer to [Appendix C](#) for hand testing requirements. Perform each test on all supported CA modes defined in [Table 6-33](#) and [Table 6-34](#) according to the use cases associated with each band as specified in [Table 6-33](#) and [Table 6-34](#) with the EUT antenna extended and retracted, as applicable.

Note: *Head-adjacent testing is not required for LTE LAA CA.*

Note: *EUTs incapable of supporting the aggregated channel BW associated the LAA CA modes specified in [Table 6-33](#) and [Table 6-34](#) do not need to be tested.*

6.21.2 Criteria

Results shall be reported for the Band 46 radiated sensitivity as specified in [Appendix B](#) using the figures of merit given in [Appendix B.3](#). [Appendix B.1](#) contains the pass/fail OTA tables for both cases where Band 46 TIS is fully measured for a given downlink LTE LAA carrier aggregation combination and where Band 46 radiated sensitivity is evaluated using the LAA un-licensed degradation test for a given downlink LTE LAA carrier aggregation combination. Reports shall include results for free-space and hand only configurations (if applicable) across all applicable channels defined in [Table 6-33](#) and [Table 6-34](#). When applicable, the Band 46 receiver performance in all LTE LAA CA band combinations shall be measured once with the EUT antenna extended and again with it retracted.

TABLE 6-35 LTE MAXIMUM C-TIS LEVEL FOR ALL ANTENNAS (IN dBm) REQUIREMENTS FOR PCC AND SCC IN CARRIER AGGREGATION MODE (2 DOWNLINK CARRIERS, 1 UPLINK CARRIER) FOR THE PRIMARY MECHANICAL MODE¹

Carrier Aggregation Combination	PCC / SCC	Device Held Up to Head for Voice (Yes/No)	Device Width (mm) ²	Free Space	HL and HR
CA_2A-46A	PCC	Yes ⁴	≤72	TBD	TBD
			>72	TBD	TBD
		No ⁵	All	TBD	N/A
	SCC	Yes ⁴	≤72	TBD	TBD
			>72	TBD	TBD
		No ⁵	All	TBD	N/A
CA_4A-46A	PCC	Yes ⁴	≤72	TBD	TBD
			>72	TBD	TBD
		No ⁵	All	TBD	N/A
	SCC	Yes ⁴	≤72	TBD	TBD
			>72	TBD	TBD
		No ⁵	All	TBD	N/A
CA_5A-46A	PCC	Yes ⁴	≤72	TBD	TBD
			>72	TBD	TBD
		No ⁵	All	TBD	N/A
	SCC	Yes ⁴	≤72	TBD	TBD
			>72	TBD	TBD
		No ⁵	All	TBD	N/A
CA_12A-46A	PCC	Yes ⁴	≤72	TBD	TBD
			>72	TBD	TBD
		No ⁵	All	TBD	N/A
	SCC	Yes ⁴	≤72	TBD	TBD
			>72	TBD	TBD
		No ⁵	All	TBD	N/A
CA_13A-46A	PCC	Yes ⁴	≤72	TBD	TBD
			>72	TBD	TBD
		No ⁵	All	TBD	N/A
	SCC	Yes ⁴	≤72	TBD	TBD
			>72	TBD	TBD
		No ⁵	All	TBD	N/A

TABLE 6-35 LTE MAXIMUM C-TIS LEVEL FOR ALL ANTENNAS (IN dBm) REQUIREMENTS FOR PCC AND SCC IN CARRIER AGGREGATION MODE (2 DOWNLINK CARRIERS, 1 UPLINK CARRIER) FOR THE PRIMARY MECHANICAL MODE¹

Carrier Aggregation Combination	PCC / SCC	Device Held Up to Head for Voice (Yes/No)	Device Width (mm) ²	Free Space	HL and HR
CA_25A-46A	PCC	Yes ⁴	≤72	TBD	TBD
			>72	TBD	TBD
		No ⁵	All	TBD	N/A
	SCC	Yes ⁴	≤72	TBD	TBD
			>72	TBD	TBD
		No ⁵	All	TBD	N/A
CA_26A-46A	PCC	Yes ⁴	≤72	TBD	TBD
			>72	TBD	TBD
		No ⁵	All	TBD	N/A
	SCC	Yes ⁴	≤72	TBD	TBD
			>72	TBD	TBD
		No ⁵	All	TBD	N/A
CA_30A-46A	PCC	Yes ⁴	≤72	TBD	TBD
			>72	TBD	TBD
		No ⁵	All	TBD	N/A
	SCC	Yes ⁴	≤72	TBD	TBD
			>72	TBD	TBD
		No ⁵	All	TBD	N/A
CA_41A-46A	PCC	Yes ⁴	≤72	TBD	TBD
			>72	TBD	TBD
		No ⁵	All	TBD	N/A
	SCC	Yes ⁴	≤72	TBD	TBD
			>72	TBD	TBD
		No ⁵	All	TBD	N/A

TABLE 6-35 LTE MAXIMUM C-TIS LEVEL FOR ALL ANTENNAS (IN dBm) REQUIREMENTS FOR PCC AND SCC IN CARRIER AGGREGATION MODE (2 DOWNLINK CARRIERS, 1 UPLINK CARRIER) FOR THE PRIMARY MECHANICAL MODE¹

Carrier Aggregation Combination	PCC / SCC	Device Held Up to Head for Voice (Yes/No)	Device Width (mm) ²	Free Space	HL and HR
CA_66A-46A	PCC	Yes ⁴	≤72	TBD	TBD
			>72	TBD	TBD
		No ⁵	All	TBD	N/A
	SCC	Yes ⁴	≤72	TBD	TBD
			>72	TBD	TBD
		No ⁵	All	TBD	N/A

Note 1: Primary Mechanical Mode refers to device configured in preferred mode per manufacturer instructions (typically means antenna extended, fold or portrait slide open, but depends on form factor).
Note 2: Differences between requirements for devices wider and narrower than 72 mm reflect observed differences in OTA performance with different hand phantoms of up to 6 dB.
Note 3: Different limits for different channel combinations may be needed since the desense effects will be channel dependent.
Note 4: "Yes" applies if the device supports voice operation in the talking position against the head in LTE mode.
Note 5: "No" would be applicable to data-centric devices that are not held up against the head, e.g., embedded laptop solutions.

TABLE 6-36 LTE MAXIMUM C-TIS LEVEL FOR ALL ANTENNAS (IN dBm) REQUIREMENTS FOR PCC, SCC1, AND SCC2 IN CARRIER AGGREGATION MODE (3 DOWNLINK CARRIERS, 1 UPLINK CARRIER) FOR THE PRIMARY MECHANICAL MODE¹

Carrier Aggregation Combination	PCC / SCC	Device Held Up to Head for Voice (Yes/No)	Device Width (mm) ²	Free Space	HL and HR
CA_2A-4A-46A	PCC	Yes ⁴	≤72	TBD	TBD
			>72	TBD	TBD
		No ⁵	All	TBD	N/A
	SCC1	Yes ⁴	≤72	TBD	TBD
			>72	TBD	TBD
		No ⁵	All	TBD	N/A
	SCC2	Yes ⁴	≤72	TBD	TBD
			>72	TBD	TBD
		No ⁵	All	TBD	N/A

TABLE 6-36 LTE MAXIMUM C-TIS LEVEL FOR ALL ANTENNAS (IN dBm) REQUIREMENTS FOR PCC, SCC1, AND SCC2 IN CARRIER AGGREGATION MODE (3 DOWNLINK CARRIERS, 1 UPLINK CARRIER) FOR THE PRIMARY MECHANICAL MODE¹

Carrier Aggregation Combination	PCC / SCC	Device Held Up to Head for Voice (Yes/No)	Device Width (mm) ²	Free Space	HL and HR
CA_2A-5A-46A	PCC	Yes ⁴	≤72	TBD	TBD
			>72	TBD	TBD
	SCC1	No ⁵	All	TBD	N/A
		Yes ⁴	≤72	TBD	TBD
			>72	TBD	TBD
		No ⁵	All	TBD	N/A
SCC2	Yes ⁴	≤72	TBD	TBD	
		>72	TBD	TBD	
CA_2A-12A-46A	PCC	Yes ⁴	≤72	TBD	TBD
			>72	TBD	TBD
	SCC1	No ⁵	All	TBD	N/A
		Yes ⁴	≤72	TBD	TBD
			>72	TBD	TBD
		No ⁵	All	TBD	N/A
SCC2	Yes ⁴	≤72	TBD	TBD	
		>72	TBD	TBD	
CA_2A-13A-46A	PCC	Yes ⁴	≤72	TBD	TBD
			>72	TBD	TBD
	SCC1	No ⁵	All	TBD	N/A
		Yes ⁴	≤72	TBD	TBD
			>72	TBD	TBD
		No ⁵	All	TBD	N/A
SCC2	Yes ⁴	≤72	TBD	TBD	
		>72	TBD	TBD	
		No ⁵	All	TBD	N/A

TABLE 6-36 LTE MAXIMUM C-TIS LEVEL FOR ALL ANTENNAS (IN dBm) REQUIREMENTS FOR PCC, SCC1, AND SCC2 IN CARRIER AGGREGATION MODE (3 DOWNLINK CARRIERS, 1 UPLINK CARRIER) FOR THE PRIMARY MECHANICAL MODE¹

Carrier Aggregation Combination	PCC / SCC	Device Held Up to Head for Voice (Yes/No)	Device Width (mm) ²	Free Space	HL and HR
CA_2A-29A-46A	PCC	Yes ⁴	≤72	TBD	TBD
			>72	TBD	TBD
	No ⁵	All	TBD	N/A	
	SCC1	Yes ⁴	≤72	TBD	TBD
			>72	TBD	TBD
No ⁵	All	TBD	N/A		
SCC2	Yes ⁴	≤72	TBD	TBD	
		>72	TBD	TBD	
No ⁵	All	TBD	N/A		
CA_2A-66A-46A	PCC	Yes ⁴	≤72	TBD	TBD
			>72	TBD	TBD
	No ⁵	All	TBD	N/A	
	SCC1	Yes ⁴	≤72	TBD	TBD
			>72	TBD	TBD
No ⁵	All	TBD	N/A		
SCC2	Yes ⁴	≤72	TBD	TBD	
		>72	TBD	TBD	
No ⁵	All	TBD	N/A		
CA_4A-5A-46A	PCC	Yes ⁴	≤72	TBD	TBD
			>72	TBD	TBD
	No ⁵	All	TBD	N/A	
	SCC1	Yes ⁴	≤72	TBD	TBD
			>72	TBD	TBD
No ⁵	All	TBD	N/A		
SCC2	Yes ⁴	≤72	TBD	TBD	
		>72	TBD	TBD	
No ⁵	All	TBD	N/A		

TABLE 6-36 LTE MAXIMUM C-TIS LEVEL FOR ALL ANTENNAS (IN dBm) REQUIREMENTS FOR PCC, SCC1, AND SCC2 IN CARRIER AGGREGATION MODE (3 DOWNLINK CARRIERS, 1 UPLINK CARRIER) FOR THE PRIMARY MECHANICAL MODE¹

Carrier Aggregation Combination	PCC / SCC	Device Held Up to Head for Voice (Yes/No)	Device Width (mm) ²	Free Space	HL and HR
CA_4A-12A-46A	PCC	Yes ⁴	≤72	TBD	TBD
			>72	TBD	TBD
	No ⁵	All	TBD	N/A	
	SCC1	Yes ⁴	≤72	TBD	TBD
			>72	TBD	TBD
No ⁵	All	TBD	N/A		
SCC2	Yes ⁴	≤72	TBD	TBD	
		>72	TBD	TBD	
No ⁵	All	TBD	N/A		
CA_4A-13A-46A	PCC	Yes ⁴	≤72	TBD	TBD
			>72	TBD	TBD
	No ⁵	All	TBD	N/A	
	SCC1	Yes ⁴	≤72	TBD	TBD
			>72	TBD	TBD
No ⁵	All	TBD	N/A		
SCC2	Yes ⁴	≤72	TBD	TBD	
		>72	TBD	TBD	
No ⁵	All	TBD	N/A		
CA_5A-12A-46A	PCC	Yes ⁴	≤72	TBD	TBD
			>72	TBD	TBD
	No ⁵	All	TBD	N/A	
	SCC1	Yes ⁴	≤72	TBD	TBD
			>72	TBD	TBD
No ⁵	All	TBD	N/A		
SCC2	Yes ⁴	≤72	TBD	TBD	
		>72	TBD	TBD	
No ⁵	All	TBD	N/A		

TABLE 6-36 LTE MAXIMUM C-TIS LEVEL FOR ALL ANTENNAS (IN dBm) REQUIREMENTS FOR PCC, SCC1, AND SCC2 IN CARRIER AGGREGATION MODE (3 DOWNLINK CARRIERS, 1 UPLINK CARRIER) FOR THE PRIMARY MECHANICAL MODE¹

Carrier Aggregation Combination	PCC / SCC	Device Held Up to Head for Voice (Yes/No)	Device Width (mm) ²	Free Space	HL and HR
CA_30A-12A-46A	PCC	Yes ⁴	≤72	TBD	TBD
			>72	TBD	TBD
	No ⁵	All	TBD	N/A	
	SCC1	Yes ⁴	≤72	TBD	TBD
			>72	TBD	TBD
No ⁵	All	TBD	N/A		
SCC2	Yes ⁴	≤72	TBD	TBD	
		>72	TBD	TBD	
No ⁵	All	TBD	N/A		
CA_41C-46A	PCC	Yes ⁴	≤72	TBD	TBD
			>72	TBD	TBD
	No ⁵	All	TBD	N/A	
	SCC1	Yes ⁴	≤72	TBD	TBD
			>72	TBD	TBD
No ⁵	All	TBD	N/A		
SCC2	Yes ⁴	≤72	TBD	TBD	
		>72	TBD	TBD	
No ⁵	All	TBD	N/A		
CA_66A-5A-46A	PCC	Yes ⁴	≤72	TBD	TBD
			>72	TBD	TBD
	No ⁵	All	TBD	N/A	
	SCC1	Yes ⁴	≤72	TBD	TBD
			>72	TBD	TBD
No ⁵	All	TBD	N/A		
SCC2	Yes ⁴	≤72	TBD	TBD	
		>72	TBD	TBD	
No ⁵	All	TBD	N/A		

TABLE 6-36 LTE MAXIMUM C-TIS LEVEL FOR ALL ANTENNAS (IN dBm) REQUIREMENTS FOR PCC, SCC1, AND SCC2 IN CARRIER AGGREGATION MODE (3 DOWNLINK CARRIERS, 1 UPLINK CARRIER) FOR THE PRIMARY MECHANICAL MODE¹

Carrier Aggregation Combination	PCC / SCC	Device Held Up to Head for Voice (Yes/No)	Device Width (mm) ²	Free Space	HL and HR
CA_66A-12A-46A	PCC	Yes ⁴	≤72	TBD	TBD
			>72	TBD	TBD
	SCC1	No ⁵	All	TBD	N/A
		Yes ⁴	≤72	TBD	TBD
	SCC2		>72	TBD	TBD
		No ⁵	All	TBD	N/A
CA_66A-13A-46A	PCC	Yes ⁴	≤72	TBD	TBD
			>72	TBD	TBD
	SCC1	No ⁵	All	TBD	N/A
		Yes ⁴	≤72	TBD	TBD
	SCC2		>72	TBD	TBD
		No ⁵	All	TBD	N/A
CA_66A-66A-46A	PCC	Yes ⁴	≤72	TBD	TBD
			>72	TBD	TBD
	SCC1	No ⁵	All	TBD	N/A
		Yes ⁴	≤72	TBD	TBD
	SCC2		>72	TBD	TBD
		No ⁵	All	TBD	N/A

Note 1: Primary Mechanical Mode refers to device configured in preferred mode per manufacturer instructions (typically means antenna extended, fold or portrait slide open, but depends on form factor).
Note 2: Differences between requirements for devices wider and narrower than 72 mm reflect observed differences in OTA performance with different hand phantoms of up to 6 dB.
Note 3: Different limits for different channel combinations may be needed since the desense effects will be channel dependent.
Note 4: "Yes" applies if the device supports voice operation in the talking position against the head in LTE mode.
Note 5: "No" would be applicable to data-centric devices that are not held up against the head, e.g., embedded laptop solutions.

6.22 LTE Category NB1 (NB-IoT)

6.22.1 Test Procedure

Category NB1 receiver sensitivity measurements shall be performed using data throughput as the measurement metric. The EUT's receiver sensitivity corresponds to the minimum downlink signal power required to provide a data throughput rate greater than or equal to 95% of the maximum throughput of the reference measurement channel. Refer to [Appendix A](#) for set-up illustrations.

The LTE system simulator and EUT shall be configured per 3GPP TS 36.521-1, Section 7.3F.1 (Reference sensitivity level without repetitions for Category NB1) using the default settings specified in 3GPP TS 36.521-1 and 3GPP TS 36.508 as applicable. For a given downlink RF power level, throughput shall be measured using the test procedure in section 7.3F of 3GPP TS 36.521-1 using the applicable downlink and uplink reference measurement channels defined in Annex A.3.2 and Annex A.2.4 of 3GPP TS 36.521-1 and [Table 6-37](#).

The LTE system simulator shall send continuous uplink power control "up" commands to the EUT to ensure the EUT's transmitter is at maximum output power during the sensitivity searches. The downlink power step size shall be no more than 0.5 dB when the RF power level is near the LTE sensitivity level. The minimum RF power level resulting in a data throughput rate greater than or equal to 95% of the maximum throughput of the reference measurement channel shall be recorded as the downlink power level corresponding to the 95% throughput percentage (the data throughput rate is as defined in section 7.3F of 3GPP TS 36.521-1). C-TIS shall be based on the minimum RF power level resulting in a data throughput rate greater than or equal to 95% of the maximum throughput of the reference measurement. Care must be taken to ensure that the duration of the throughput measurement is sufficient to achieve statistical significance according to Annex G.2 of 3GPP TS 36.521-1. The downlink signal level for each EUT test condition shall be recorded for integration pursuant to [Appendix B.3](#) to give a single figure of merit referred to as Combined Total Isotropic Sensitivity (C-TIS).

Typically, the maximum deviation in receive level measurements from peak to null of any one channel does not exceed 30 dB. Therefore, the test facility may elect to initiate each sensitivity measurement starting with the base station power set 30 dB above the lowest sensitivity level measured in order to reduce the time required to search for the sensitivity floor. For points where this setting is below the target sensitivity level, the sensitivity may be considered negligible for that location and the initial value used in place of an actual measurement.

C-TIS shall be fully measured as described above and calculated pursuant to [Appendix B.3](#). C-TIS measurements shall be carried out for the frequency pairs defined in [Table 6-37](#), according to the bands supported by the EUT. C-TIS results shall be based on total channel power.

TABLE 6-37 LTE CATEGORY NB1 TIS/C-TIS MEASUREMENTS TABLE FOR STAND-ALONE (SA) OPERATION USING QPSK (15 KHZ SUB-CARRIER SPACING) IN THE PRIMARY MECHANICAL MODE¹

Band	Range	NB1 DL EARFCN	DL Offset to NB1 EARFCN	Frequency of NB1 DL EARFCN	Uplink Configuration		Downlink Configuration	
		N_{DL}	M_{DL}	F_{DL} (MHz)	Modulation	N_{tones}	Modulation	Subcarriers
2 ²	Low	601	-0.5	1930.10	$\pi/2$ BPSK	1@0	QPSK	12
2 ²	Mid	900	-0.5	1960.00	$\pi/2$ BPSK	1@0	QPSK	12

TABLE 6-37 LTE CATEGORY NB1 TIS/C-TIS MEASUREMENTS TABLE FOR STAND-ALONE (SA) OPERATION USING QPSK (15 KHZ SUB-CARRIER SPACING) IN THE PRIMARY MECHANICAL MODE¹

Band	Range	NB1 DL EARFCN	DL Offset to NB1 EARFCN	Frequency of NB1 DL EARFCN	Uplink Configuration		Downlink Configuration	
		N_{DL}	M_{DL}	F_{DL} (MHz)	Modulation	N_{tones}	Modulation	Subcarriers
2 ²	High	1199	-0.5	1989.90	$\pi/2$ BPSK	1@0	QPSK	12
4 ³	Low	1951	-0.5	2110.10	$\pi/2$ BPSK	1@0	QPSK	12
4 ³	Mid	2175	-0.5	2132.50	$\pi/2$ BPSK	1@0	QPSK	12
4 ³	High	2399	-0.5	2154.90	$\pi/2$ BPSK	1@0	QPSK	12
5 ⁴	Low	2401	-0.5	869.10	$\pi/2$ BPSK	1@0	QPSK	12
5 ⁴	Mid	2525	-0.5	881.50	$\pi/2$ BPSK	1@0	QPSK	12
5 ⁴	High	2649	-0.5	893.90	$\pi/2$ BPSK	1@0	QPSK	12
12 ⁵	Low	5011	-0.5	729.10	$\pi/2$ BPSK	1@0	QPSK	12
12 ⁵	Mid	5095	-0.5	737.50	$\pi/2$ BPSK	1@0	QPSK	12
12 ⁵	High	5179	-0.5	745.90	$\pi/2$ BPSK	1@0	QPSK	12
13	Low	5181	-0.5	746.10	$\pi/2$ BPSK	1@0	QPSK	12
13	Mid	5230	-0.5	751.00	$\pi/2$ BPSK	1@0	QPSK	12
13	High	5279	-0.5	755.90	$\pi/2$ BPSK	1@0	QPSK	12
14	Low	5281	-0.5	758.10	$\pi/2$ BPSK	1@0	QPSK	12
14	Mid	5330	-0.5	763.00	$\pi/2$ BPSK	1@0	QPSK	12
14	High	5379	-0.5	767.90	$\pi/2$ BPSK	1@0	QPSK	12
17 ⁵	Low	5731	-0.5	734.10	$\pi/2$ BPSK	1@0	QPSK	12
17 ⁵	Mid	5790	-0.5	740.00	$\pi/2$ BPSK	1@0	QPSK	12
17 ⁵	High	5849	-0.5	745.90	$\pi/2$ BPSK	1@0	QPSK	12
25 ²	Low	8041	-0.5	1930.10	$\pi/2$ BPSK	1@0	QPSK	12
25 ²	Mid	8365	-0.5	1962.50	$\pi/2$ BPSK	1@0	QPSK	12
25 ²	High	8689	-0.5	1994.90	$\pi/2$ BPSK	1@0	QPSK	12
26 ⁴	Low	8691	-0.5	859.10	$\pi/2$ BPSK	1@0	QPSK	12
26 ⁴	Mid	8865	-0.5	876.50	$\pi/2$ BPSK	1@0	QPSK	12
26 ⁴	High	9039	-0.5	893.90	$\pi/2$ BPSK	1@0	QPSK	12
66 ³	Low	66437	-0.5	2110.10	$\pi/2$ BPSK	1@0	QPSK	12
66 ³	Mid	66786	-0.5	2145.00	$\pi/2$ BPSK	1@0	QPSK	12
66 ³	High	67135	-0.5	2179.90	$\pi/2$ BPSK	1@0	QPSK	12
71	Low	68587	-0.5	617.10	$\pi/2$ BPSK	1@0	QPSK	12
71	Mid	68761	-0.5	634.50	$\pi/2$ BPSK	1@0	QPSK	12
71	High	68935	-0.5	651.90	$\pi/2$ BPSK	1@0	QPSK	12

Note 1: Primary Mechanical Mode refers to device configured in preferred mode per manufacturer instructions (typically means antenna extended, fold or portrait slide open, but depends on form factor).

Note 2: If the device supports Band 25 and Band 2, then testing is only required to be completed in Band 25.

Note 3: If the device supports Band 4 and Band 66, then testing is only required to be completed in Band 66.

Note 4: If the device supports Band 26 and Band 5, then testing is only required to be completed in Band 26.

Note 5: If the device supports Band 12 and Band 17, then testing is only required to be completed in Band 12.

Forearm and/or free-space testing shall be conducted based on device type, as specified in [Appendix O](#). Refer to [Appendix Q](#) for forearm testing requirements. Perform each test on all specified frequencies and RB allocations with the EUT antenna extended and retracted, as applicable.

6.22.2 Criteria

Results shall be reported as specified in [Appendix B](#) using the figures of merit given in [Appendix B.3](#). [Appendix B.1](#) contains the pass/fail OTA tables for LTE Category NB-1. Pass/fail criteria for LTE Category NB-1 is for future study, and different pass/fail criteria may be developed for different device types/use cases. Reports shall include results for applicable use cases, including free-space and/or wrist-worn configurations across all relevant channels measured with the EUT in primary mechanical mode, and (if applicable) in non-primary mechanical modes as reference information.

TABLE 6-38 LTE CATEGORY NB1 TIS LEVEL (DBM) FOR STAND-ALONE (SA) OPERATION USING QPSK (15 KHZ SUB-CARRIER SPACING) IN THE PRIMARY MECHANICAL MODE¹

Band	Device Worn on Wrist?	FS	WL and WR
LTE Band 71	Yes	N/A	TBD
	No	TBD	N/A
LTE Band 12	Yes	N/A	TBD
	No	TBD	N/A
LTE Band 13	Yes	N/A	TBD
	No	TBD	N/A
LTE Band 14	Yes	N/A	TBD
	No	TBD	N/A
LTE Band 17	Yes	N/A	TBD
	No	TBD	N/A
LTE Band 26	Yes	N/A	TBD
	No	TBD	N/A
LTE Band 5	Yes	N/A	TBD
	No	TBD	N/A
LTE Band 25	Yes	N/A	TBD
	No	TBD	N/A
LTE Band 2	Yes	N/A	TBD
	No	TBD	N/A
LTE Band 4	Yes	N/A	TBD
	No	TBD	N/A
LTE Band 66	Yes	N/A	TBD
	No	TBD	N/A

Note 1: Primary Mechanical Mode refers to device configured in preferred mode per manufacturer instructions (typically means antenna extended, fold or portrait slide open, but depends on form factor).

6.23 New Radio (NR) Frequency Range 1 (FR1) (Informative)

The TIS test procedure for NR FR1 shall be performed using the procedure identified in [Section 6.23.1](#).

6.23.1 Test Procedure

Receiver sensitivity measurements shall be performed using data throughput as the measurement metric. The EUT's receiver sensitivity corresponds to the minimum downlink signal power required to provide a data throughput rate greater than or equal to 95% of the maximum throughput of the reference measurement channel. Refer to [Appendix A](#) for set-up illustrations.

For a device supporting multiple receivers, all receivers shall be enabled during the test procedure described in the remainder of this section. In this way, C-TIS is the test result, regardless whether the device supports one or multiple receivers. In the special case that I-TIS is the desired quantity of interest, the same procedure is followed, except that all but the specified receiver-under-test on the device are disabled.

The NR system simulator and EUT shall be configured per section 7.3 (Reference Sensitivity) of 3GPP TS 38.521-1 using the defaults specified in 3GPP TS 38.521-1 and 3GPP TS 38.508-1 as applicable. As the 3GPP reference does not make any mention of p-Max, nor is p-Max included in the default message content defined in 3GPP TS 38.508-1, p-Max shall not be signaled during attach procedures or during measurements. For a given downlink RF power level, throughput shall be measured using the test procedure in section 7.3.2 (Reference sensitivity power level) of 3GPP TS 38.521-1 using the downlink and uplink reference measurement channels defined in Annexes A.2.2, A.2.3, and A.3.2 of 3GPP TS 38.521-1 and [Table 6-35](#). The NR system simulator shall send continuous uplink power control "up" commands to the EUT to ensure the EUT's transmitter is at maximum output power during the sensitivity searches. The downlink power step size shall be no more than 0.5 dB when the RF power level is near the NR sensitivity level. The minimum RF power level resulting in a data throughput rate greater than or equal to 95% of the maximum throughput of the reference measurement channel shall be recorded as the downlink power level corresponding to the 95% throughput percentage (the data throughput rate is as defined in section 7.3.2.3 of 3GPP TS 38.521-1). Care must be taken to ensure that the duration of the throughput measurement is sufficient to achieve statistical significance according to Annex H.2 of 3GPP TS 38.521-1. The downlink signal level for each EUT test condition shall be recorded for integration pursuant to [Appendix B.3](#) to give a single figure of merit referred to as Total Isotropic Sensitivity (TIS).

Typically, the maximum deviation in receive level measurements from peak to null of any one channel does not exceed 30 dB. Therefore, the test facility may elect to initiate each sensitivity measurement starting with the base station power set 30 dB above the lowest sensitivity level measured in order to reduce the time required to search for the sensitivity floor. For points where this setting is below the target sensitivity level, the sensitivity may be considered negligible for that location and the initial value used in place of an actual measurement.

TIS shall be fully measured as described above and calculated pursuant to [Appendix B.3](#). TIS measurements shall be carried out for different frequency pairs (FDD; UL -uplink /DL -downlink) or frequencies (TDD) and RB allocations across the bands supported by the EUT, as defined in [Table 6-35](#). TIS results shall be based on total channel power.

TABLE 6-39 NR FR1 TIS MEASUREMENTS TABLE FOR THE PRIMARY MECHANICAL MODE¹

Band	Channel Bandwidth (MHz)	SCS (kHz)	Channel	Carrier Center Frequency (MHz)	UL Configuration	DL Configuration
n2	10	15	387000	1935	50@0	52@0
			392000	1960	50@0	52@0
			397000	1985	50@0	52@0
n5	10	15	174800	874	25@25	52@0
			176300	881.5	25@25	52@0
			177800	889	25@25	52@0
n41	100	30	509202	2546.01	270@0	273@0
			518598	2592.99	270@0	273@0
			528000	2640	270@0	273@0
n66	10	15	423000	2115	50@0	52@0
			429000	2145	50@0	52@0
			435000	2175	50@0	52@0
	20	15	424000	2120	100@0	106@0
			429000	2145	100@0	106@0
			434000	2170	100@0	106@0
	40	15	426000	2130	216@0	216@0
			429000	2145	216@0	216@0
			432000	2160	216@0	216@0
436000			2180	100@0 ²	216@0	
n70	15	15	400500	2002.5	75@0	79@0
	25	15	401500	2007.5	75@0 ³	133@0
n71	10	15	124400	622	25@0	52@0
			126900	634.5	25@0	52@0
			129400	647	25@0	52@0
n78	60	30	622000	3330	162@0	162@0
			636666	3549.99	162@0	162@0
			651332	3769.98	162@0	162@0
	100	30	623334	3350.01	270@0	273@0
			636666	3549.99	270@0	273@0
			650000	3750	270@0	273@0

Note 1: Primary Mechanical Mode refers to device configured in preferred mode per manufacturer instructions (typically means antenna extended, fold or portrait slide open, but depends on form factor).

Note 2: This configuration is asymmetric and UL CH BW is 20 MHz at channel 354000.

Note 3: This configuration is asymmetric and UL CH BW is 15 MHz at channel 340500.

For the TIS test, head and hand phantom, hand phantom only and/or free-space testing shall be conducted based on device type, as specified in [Appendix O](#). Refer to [Appendix C](#) for head/hand testing requirements. Perform each test on all specified frequencies with the EUT antenna extended and retracted, as applicable.

Note: Head-adjacent testing is only required for NR if the EUT supports usage against the head while utilizing an NR airlink (e.g., VoIP).

6.23.2 NR FR1 Intermediate Channel Measurements

Intermediate channel measurements for NR FR1 are not applicable at this time.

6.23.3 Criteria

Pass/fail criteria for NR FR1 is for future study, and different pass/fail criteria may be developed for different device types/use cases.

Section 7 Measurement Uncertainty

For the TRP and TIS tests described in this Test Plan, the chosen method for calculation of the measurement uncertainty is based on the “Guide to the Expression of Uncertainty in Measurement” published by the International Organization for Standardization (ISO) Geneva, Switzerland 1995.

The ISO guide gives a general approach to calculating measurement uncertainty that is applicable to all types of measurements, the process involving the combination of the standard deviations (known as standard uncertainties) of the individual contributors by the root-sum-squares method. It does, however, contain some underlying assumptions that have, in the past, made it difficult to apply the approach directly to radiated measurements. For example, it requires that all the contributors to the overall uncertainty are independent, all in the same unit and are additive, requirements that lead to difficulties particularly when contributors in %, volts and dB are involved. ETSI documents TR 102 273 and TR 100 028 have specifically addressed these problems for radiated measurements and have derived a method for converting standard uncertainties from one unit (% , volts, dB) into another. [Table 7-1](#) gives the relevant conversion factors, but TR 102 273 should be fully consulted before they are used, because there are some conditions regarding their magnitudes.

TABLE 7-1 STANDARD UNCERTAINTY CONVERSION FACTORS

Converting from standard uncertainties in ...:	Conversion factor multiply by:	To standard uncertainties in ...:
dB	11.5	voltage %
dB	23.0	power %
power %	0.0435	dB
power %	0.5	voltage %
voltage %	2.0	power %
voltage %	0.0870	dB

The requirement that the uncertainties are additive dictates that in radiated measurements (where all of the uncertainties multiply), all the individual uncertainties should be converted to dB (if necessary) so that the dBs can be added.

So, using the above to determine the method for uncertainty analysis in TRP and TIS radiated measurements, the following illustrates the practical steps involved:

1. Compile a complete list of the individual measurement uncertainties that contribute to a measurement;
2. Determine the maximum value of each uncertainty;
3. Determine the distribution of each uncertainty (rectangular, U-shaped, etc);
4. Calculate (if necessary) the standard uncertainty (i.e., standard deviation) of each uncertainty;
5. Convert the units (if necessary) of each uncertainty into the chosen unit i.e. dB;
6. Combine ALL the standard uncertainties by the root-sum-squares method to derive the 'combined standard uncertainty';
7. Under the assumption that the probability distribution of the combined standard uncertainty is Gaussian/Normal, multiply the resulting combined standard uncertainty by an expansion factor 'k' (taken from Student's T-distribution, W.S. Gosset 1908) to derive the 'expanded uncertainty' for a given confidence level. All expanded uncertainties are quoted to 95% confidence level, so *k* is taken as 2 (theoretically *k* should be 1.96, but for convenience, the value 2 had been agreed). Expressed a different way, this gives 95% confidence that the true value is within 2 times the combined standard uncertainty of the measured value.

It is not suggested that this process be carried out at every individual test frequency since this would be extremely time consuming and tedious. Rather, for each band (e.g. 824 - 894 MHz for Cellular, 1850 - 1990 MHz for PCS, etc.), unless only a single value is specified, all the uncertainties should be evaluated over the entire frequency range for that band and the worst-case values within the band taken and used in the calculations. Admittedly, this could lead to slightly pessimistic overall values, but the bonus is in reduced measurement time and a one-hit process that will be applicable to any frequency within the relevant band.

The uncertainty contributions are determined experimentally. The relative uncertainty parameters can also be determined by simulations provided that it can be guaranteed that the relative accuracy is significantly better than 0.1 dB (see [Appendix I](#)).

In [Section 7.1](#) and [Section 7.2](#), this calculation process is fully described for the TRP and TIS tests of this Test Plan respectively.

7.1 TRP Tests

The TRP test method determines the unknown performance of the EUT by correcting the absolute power measurements at the input port of the test instrumentation using a relative correction value determined using the range reference measurement described in [Section 4](#). This correction value offsets each power measurement back to the equivalent power that would have been radiated by a theoretical isotropic radiator in order to produce the same measured level. This corrected value is known as the Effective Isotropic Radiated Power (EIRP), which is then integrated across the total spherical surface to determine the Total Radiated Power. To reduce the overall measurement uncertainty, the same cable configuration and equipment used during the reference measurement ([Section 4](#)) should also be used during the EUT measurement phase, rather than measuring individual components and applying the corrections separately. In this way, a number of the individual uncertainty contributions will cancel simply because they contribute the same uncertainty to both the reference measurement and the EUT measurement, e.g. the uncertainty in the insertion loss of the cable(s) between the Measurement Antenna and the Spectrum Analyzer/Measurement Receiver, the uncertainty in the Gain of the Measurement Antenna, etc.

7.1.1 EUT Measurement

In this part of the measurement, the EUT and any associated phantom combination is positioned on the turntable within the quiet zone of the chamber, trying to place its reference point (as defined in [Appendix A.1](#)) on the axes of rotation in both theta and phi (if present). At the other end, the Spectrum Analyzer, Measurement Receiver or Base Station simulator will be connected via a cable and/or attenuator to the Measurement Antenna.

The identified uncertainties in this part are listed in [Table 7-2](#). Where 0.00 dB values are entered in [Table 7-2](#), this means that the uncertainty contribution appears in the reference measurement also and therefore cancels. It is a critical step in any such uncertainty evaluation to determine precisely where the transition occurs between the equipment that appears exactly in both measurements, vs. the equipment that changes between the reference measurement and the EUT measurement. The uncertainty contributions that can be assumed to cancel are those contributions associated with system components that are measured in the reference measurement. Since components such as the measurement antenna and associated cables are measured in the reference measurement, there is one lump uncertainty associated with that measurement, rather than the individual uncertainties of each component.

Appendix G gives guidance on calculating the values to be entered in Table 7-2.

TABLE 7-2 TRP STANDARD UNCERTAINTIES FOR THE CONTRIBUTIONS IN THE EUT MEASUREMENT PART

Description of uncertainty contributions	Standard Uncertainty, dB
Mismatch: measurement instrument (i.e., between the receiving device and the rest of the signal path [the measurement path])	See Appendix G.1
Cable factor: measurement antenna cable (i.e. how the cable interacts with the measurement)	See Appendix G.2
Insertion loss: measurement antenna cable	0.00
Insertion loss: measurement antenna attenuator (if present)	0.00
Receiving device: absolute level	See Appendix G.4
Antenna: gain of the measurement antenna	0.00
Measurement distance: <ul style="list-style-type: none"> • offset of EUT phase center from center of rotation • 'blocking' effect of EUT on measurement antenna <ul style="list-style-type: none"> - VSWR - Chamber standing wave • phase curvature across the EUT 	See Appendix G.7
Signal level ripple within quiet zone	See Appendix G.8.1
EUT: influence of the ambient temperature on the ERP of the carrier	See Appendix G.9
Head phantom uncertainty	See Appendix G.10.2, Appendix C.2.1
Hand phantom uncertainty	See Appendix G.10.3 and Appendix G.10.8
Forearm phantom uncertainty	See Appendix G.24.2
Head phantom fixture uncertainty	See Appendix G.10.4
Hand phantom fixture uncertainty	See Appendix G.10.4 and Appendix G.10.8
Forearm phantom fixture uncertainty	0.00 See Appendix Q.5.3
EUT positioning uncertainty	See Appendix G.21, Appendix G.10.8 Appendix G.24.2
Miscellaneous uncertainty (measurement system repeatability)	See Appendix G.13
Special considerations for notebooks	See Appendix G.19
Frequency flatness and interpolation error	See Appendix G.22

Once all the relevant standard uncertainty values in [Table 7-2](#) have been calculated, they should be combined by root-sum-squares to give the combined standard uncertainty

u_c contribution from the EUT measurement for this part of the test.

7.1.2 Reference Measurement

This is the Range Reference Measurement as given in [Section 4](#), the output of which is the Path Loss. It is believed that the uncertainty of the path loss calculation is a significant factor dictating the accuracy of the measured TRP value. Any error in the path loss calculation (e.g., error in the gain of the reference antenna) will result in an offset in the TRP value.

The contributors to the overall uncertainty of this part of the measurement are given in [Table 7-3](#). Again, the contributors that appear in both parts of the measurement are put equal to 0.00 because they have the same effect in both parts, provided the relevant parts of the test set-up have not been changed. Once all the standard uncertainty values have been derived, they shall be combined by root-sum-squares to give the following combined standard uncertainty

u_c contribution from the reference measurement for this part of the test.

[Appendix G](#) gives guidance on calculating the values to be entered in [Table 7-3](#).

TABLE 7-3 STANDARD UNCERTAINTIES FOR THE CONTRIBUTIONS TO THE REFERENCE MEASUREMENT

Description of uncertainty contributions	Standard Uncertainty, dB
Mismatch: cable reference measurement (i.e., between the reference cable and the loopback cable)	See Appendix G.1
Mismatch: reference antenna (i.e., between the reference cable and the reference antenna)	See Appendix G.1
Mismatch: measurement path (i.e., between the loopback cable and the rest of the cable that connects to the measurement equipment)	See Appendix G.1
Signal generator: absolute output level	See Appendix G.5
Signal generator: output level stability	See Appendix G.5
Insertion loss: calibrated reference antenna cable	See Appendix G.3
Insertion loss: measurement antenna cable	0.00
Insertion loss: calibrated reference antenna attenuator (if present)	See Appendix G.3
Insertion loss: measurement antenna attenuator (if present)	0.00
Receiving device: absolute level	See Appendix G.4
Measurement distance: offset of phase center of calibrated reference antenna from the center of rotation	See Appendix G.7.2

TABLE 7-3 STANDARD UNCERTAINTIES FOR THE CONTRIBUTIONS TO THE REFERENCE MEASUREMENT

Description of uncertainty contributions	Standard Uncertainty, dB
Signal level ripple within quiet zone	See Appendix G.8.2
Antenna: gain of the calibrated reference antenna	See Appendix G.6
Antenna: gain of the measurement antenna	0.00

7.1.3 Calculation of the Combined and Expanded Uncertainties for the Overall TRP Measurement

Having calculated the combined standard uncertainties from the two parts of the measurement, they should be combined as follows to derive the overall combined standard uncertainty:

$$u_c = \sqrt{u_c^2 \text{ contribution from the EUT measurement} + u_c^2 \text{ contribution from the reference measurement}}$$

From this, the expanded uncertainty, U , is calculated as $U = 2 \cdot u_c$ for a 95 % confidence level.

This is the resulting value of the TRP expanded uncertainty and should be stated in the results sheet.

7.2 TIS Tests

The TIS test method is similar to the TRP method above, in that the range reference measurement is used to correct the unknown performance of the EUT back to values relative to that of a theoretical isotropic receiver. In this case, the correction value offsets each sensitivity level measurement back to the equivalent sensitivity level of a theoretical isotropic receiver exposed to an incoming isotropic wave with the same magnitude. This corrected value is known as the Effective Isotropic Sensitivity (EIS), which is then integrated across the total spherical surface to determine the Total Isotropic Sensitivity. As above, a number of individual uncertainty contributions will cancel, provided there have only been a minimum number of changes between the two parts of the measurement.

7.2.1 EUT Measurement

In this part of the measurement, the EUT is positioned within the quiet zone of the turntable, again trying to position its ear reference point on the axes of rotation in both azimuth and elevation (if present). At the other end, the Base Station Simulator will be connected via a cable and/or attenuator to the Measurement Antenna.

The identified uncertainties in this part are listed in [Table 7-4](#).

[Appendix G](#) gives guidance on calculating the values to be entered in [Table 7-4](#).

TABLE 7-4 TIS STANDARD UNCERTAINTIES FOR THE CONTRIBUTIONS IN THE EUT MEASUREMENT PART

Description of uncertainty contributions	Standard Uncertainty, dB
Mismatch: measurement instrument (i.e., between the transmitting device and the rest of the signal path [the measurement path])	See Appendix G.1
Base station/satellite simulator: absolute output level	See Appendix G.5
Base station/satellite simulator: output level stability	See Appendix G.5

TABLE 7-4 TIS STANDARD UNCERTAINTIES FOR THE CONTRIBUTIONS IN THE EUT MEASUREMENT PART

Description of uncertainty contributions	Standard Uncertainty, dB
Cable factor: measurement antenna cable (i.e. how the cable interacts with the measurement)	0.00
Insertion loss: measurement antenna cable	0.00
Insertion loss measurement antenna attenuator (if present)	0.00
Sensitivity search step size	See Appendix G.11
EUT influence of ambient temperature on the EIS	See Appendix G.9
Measurement distance: <ul style="list-style-type: none"> • offset of EUT phase center from center of rotation • 'blocking' effect of EUT on measurement antenna <ul style="list-style-type: none"> - VSWR - Chamber standing wave • phase curvature across the EUT 	See Appendix G.7
Signal level ripple within quiet zone	See Appendix G.8.1
Antenna: gain of the measurement antenna	0.00
Head phantom uncertainty	See Appendix G.10.2 , Appendix C.2.1
Hand phantom uncertainty	See Appendix G.10.3 and Appendix G.10.8
Forearm phantom uncertainty	See Appendix G.24.1
Head phantom fixture uncertainty	See Appendix G.10.4
Hand phantom fixture uncertainty	See Appendix G.10.4 and Appendix G.10.8
Forearm phantom fixture uncertainty	0.00 See Appendix Q.5.3
EUT positioning uncertainty	See Appendix G.21 , Appendix G.10.8 and Appendix G.24.2
Coarse sampling grid contribution	See Appendix G.12
Miscellaneous uncertainty	See Appendix G.13
Special considerations for notebooks	See Appendix G.19
Frequency flatness and interpolation error	See Appendix G.22
The following additional items apply to RSS-based TIS:	
Base station/satellite simulator: relative output level	See Appendix G.5

TABLE 7-4 TIS STANDARD UNCERTAINTIES FOR THE CONTRIBUTIONS IN THE EUT MEASUREMENT PART

Description of uncertainty contributions	Standard Uncertainty, dB
EUT repositioning uncertainty	See Appendix G.21
Linearization of conducted/radiated RSS measurement	See Appendix G.16
Uncertainty of RSS data from EUT	See Appendix G.17
Quantization of EUT reporting mechanism for RSS data	See Appendix G.18

The standard uncertainties from [Table 7-4](#) should be combined by root-sum-squares to give the combined standard uncertainty u_c contribution from the EUT measurement for this part of the test.

7.2.2 Reference Measurement

This is the identical analysis to that given in [Section 7.1.2](#) above since it is the same Range Reference Measurement as described in [Section 4](#), the output of which is the Path Loss.

The contributors to the overall uncertainty of this part of the measurement are given in [Table 7-5](#). Again, those contributors that appear in both parts of the measurement are put equal to 0.00 because they have the same effect in both parts. Once all the standard uncertainty values have been derived, they should be combined by root-sum-squares to give the combined standard uncertainty u_c contribution from the reference measurement for this part of the test.

[Appendix G](#) gives guidance on calculating the values to be entered in [Table 7-5](#).

TABLE 7-5 STANDARD UNCERTAINTIES FOR THE CONTRIBUTIONS TO THE REFERENCE MEASUREMENT

Description of uncertainty contributions	Standard Uncertainty, dB
Mismatch: cable reference measurement (i.e., between the reference cable and the loopback cable)	See Appendix G.1
Mismatch: reference antenna (i.e., between the reference cable and the reference antenna)	See Appendix G.1
Mismatch: measurement path (i.e., between the loopback cable and the rest of the cable that connects to the measurement equipment)	See Appendix G.1
Signal generator: absolute output level	See Appendix G.5
Signal generator: output level stability	See Appendix G.5
Insertion loss: Calibrated reference antenna cable	See Appendix G.3
Insertion loss: measurement antenna cable	0.00
Insertion loss: calibrated reference antenna attenuator (if present)	See Appendix G.3
Insertion loss: measurement antenna attenuator (if present)	0.00

TABLE 7-5 STANDARD UNCERTAINTIES FOR THE CONTRIBUTIONS TO THE REFERENCE MEASUREMENT

Description of uncertainty contributions	Standard Uncertainty, dB
Receiving device: absolute level	See Appendix G.4
Measurement distance: offset of phase center of calibrated reference antenna from the center of rotation	See Appendix G.7.2
Signal level ripple within quiet zone	See Appendix G.8.2
Antenna: gain of the calibrated reference Antenna	See Appendix G.6
Antenna: gain of the measurement antenna	0.00

7.2.3 Calculation of the Combined and Expanded Uncertainties for the Overall TIS Measurement

Having calculated the combined standard uncertainties from the two parts of the measurement, they should be combined as follows to derive the overall combined standard uncertainty:

$$u_c = \sqrt{u_c^2 \text{ contribution from the EUT measurement} + u_c^2 \text{ contribution from the reference measurement}}$$

From this, the expanded uncertainty, U , is calculated as $U = 2 \cdot u_c$ for a 95 % confidence level.

This is the resulting value of the TIS expanded uncertainty and should be stated in the results sheet.

7.3 Alternate Test Procedures for TRP Measurements

7.3.1 Single/Multi-point Offset TRP Test

For purposes of clarity, test configuration A will be the reference protocol for which a full TRP measurement is performed. Test configuration B will be the other protocol to be tested using the single/multi point radiated test.

Since this alternative measurement is a relative measurement, it will not only inherit the same uncertainties as those in the full 3D TRP measurement for test configuration A but will additionally include a small number of extra uncertainties. These extra uncertainties shall be combined with the combined uncertainty of the full TRP measurement by root-sum-squares in order to derive an overall estimate for the uncertainty of this relative measurement procedure that results in an absolute level for test configuration B TRP.

Since this is a relative measurement, many of the uncertainties associated with measuring test configuration B and test configuration A with the phone in the same position, near the same time, will be the same and cancel. Therefore they will not contribute to the relative measurement. The uncertainties, which will cancel, include mismatch between measurement antenna and receiving device, cable effects, insertion loss of the measurement antenna cable and attenuator, measurement antenna gain, measurement distance, signal level ripple within quiet zone, influence of ambient temperature on radiated power, and dissimilarity between calibration antenna and EUT. The error/uncertainty

contribution for each of the above items is listed in [Table 7-3](#). If the phone is not handled between measuring both test configurations, then the positioning error of EUT uncertainty will not contribute to this measurement. If the phone is handled between measuring both test configurations, then this uncertainty should be included in this measurement.

One of the additional sources of uncertainty is the variation in gain pattern over frequency. This will have a small impact if the channel bandwidth of test configuration A and test configuration B is different. For example, for CDMA and GSM the bandwidths are 1.24 MHz vs. 200 kHz. Other protocol pairs may have no variation, because their channel bandwidths are the same.

Another additional uncertainty is that associated with determining the difference in received levels of the test configurations. The magnitude of this uncertainty is minimized if the same receiving device is used for both measurements. Finally a miscellaneous uncertainty component is considered for the relative measurement.

Other than the uncertainties identified above, the test configuration B measurement will inherit the exact same errors as the test configuration A measurement.

TABLE 7-6 ADDITIONAL UNCERTAINTIES BETWEEN RELATIVE MEASUREMENT VS. FULL TRP MEASUREMENT

Description of uncertainty contributions	Added Uncertainty, dB
Mismatch: receiving part (i.e., between receiving device and measurement antenna)	0.00
Cable factor: measurement antenna cable (i.e. how the cable interacts with the measurement)	0.00
Insertion loss: measurement antenna cable	0.00
Insertion loss: measurement antenna attenuator (if present)	0.00
Receiving device: absolute level	See Appendix G.4
Antenna: gain of the measurement antenna	0.00
Measurement distance: <ul style="list-style-type: none"> • offset of EUT phase center from center of rotation • 'blocking' effect of EUT on measurement antenna <ul style="list-style-type: none"> - VSWR - Chamber standing wave • phase curvature across the EUT 	0.00
Signal level ripple within quiet zone	0.00
Influence of the ambient temperature on test equipment	0.00
EUT repositioning uncertainty	See Appendix G.21
Miscellaneous uncertainty	See Appendix G.13
Uncertainty due to difference in gain of the test antenna over the different channel bandwidths	See Appendix G.20

Calculation of absolute uncertainty for TRP calculated using a relative single-point/multi-point radiated measurement:

The non-zero uncertainty values in the table above shall be combined by root-sum-squares to produce:

u_c TRP relative measurement

The overall uncertainty for the measurement is then:

$$u_c = \sqrt{u_{c\ TRP\ relative\ measurement}^2 + u_{c\ full\ TRP\ measurement}^2}$$

From this, the expanded uncertainty, U , is calculated as $U = 2 \cdot u_c$ for a 95% confidence level.

This is the resulting value of the TRP expanded uncertainty for the alternate measurement procedure and should be stated in the results sheet.

7.4 Alternate Test Procedures for TIS Measurements

7.4.1 Single/Multi-point Offset TIS Test Procedure

For purposes of clarity, test configuration A will be protocol/error rate/data rate for which a full TIS measurement is performed. Test configuration B will be the other protocol/error rate/data rate which will be tested using the single/multi-point radiated test.

Since this alternative measurement is a relative measurement, it will not only inherit the same uncertainties as those in the full 3D TIS measurement for test configuration A but will additionally include a small number of extra uncertainties. These extra uncertainties shall be combined with the combined uncertainty of the full TIS measurement by root-sum-squares in order to derive an overall estimate for the uncertainty of this relative measurement procedure that results in an absolute level for test configuration B TIS.

Since this is a relative measurement, many of the uncertainties associated with measuring test configuration B and test configuration A with the phone in the same position, near the same time, will be the same and cancel. Therefore they will not contribute to the relative measurement. The uncertainties, which will cancel, include mismatch between measurement antenna and receiving device, cable effects, insertion loss of the measurement antenna cable and attenuator, measurement antenna gain, measurement distance, signal level ripple within quiet zone, influence of ambient temperature on radiated sensitivity, and dissimilarity between calibration antenna and EUT. The error/uncertainty contribution for each of the above items is listed in [Table 7-4](#). If the phone is not handled between measuring both test configurations, then the positioning error of EUT uncertainty will not contribute to this measurement. If the phone is handled between measuring both test configurations, then this uncertainty should be included in this measurement.

In some cases, the Alternate Test Procedure for TIS Measurements uncertainty will need to be considered multiple times. For example with CDMA, if the spherical pattern measurements are made using a 2% FER limit and subsequently a 0.5% FER limit is used to normalize the TIS measurement, an Alternate Test Procedure for TIS Measurements uncertainty would be required to be taken for this normalization. Subsequently, if the CDMA 1xEV-DO TIS is determined from the delta in the sensitivity level using a 0.5% FER/PER limit between 1xEV-DO and CDMA using CDMA as the primary method data, another independent Alternate Test Procedure for TIS Measurements uncertainty would be required to be taken.

One of the additional sources of uncertainty is the variation in gain pattern over frequency. This will have a small impact if the channel bandwidth of test configuration A and test configuration B is different. For example, for CDMA and GSM the bandwidths are 1.24 MHz vs. 200 kHz. Other test configuration pairs may have no variation, because their channel bandwidths are the same.

Another additional uncertainty is that associated with determining the difference in received levels of the test configurations. The magnitude of this uncertainty is minimized if the same base station simulator is used for both measurements. Finally a miscellaneous uncertainty component is considered for the relative measurement.

Other than the uncertainties identified above, the test configuration B measurement will inherit the exact same errors as the test configuration A measurement.

TABLE 7-7 ADDITIONAL UNCERTAINTIES BETWEEN RELATIVE MEASUREMENT VS. FULL TIS MEASUREMENT

Description of uncertainty contributions	Added Uncertainty, dB
TIS normalization uncertainty	See Appendix G.14
Mismatch: receiving part (i.e., between receiving device and measurement antenna)	0.00
Cable factor: measurement antenna cable (i.e., how the cable interacts with the measurement)	0.00
Insertion loss: measurement antenna cable	0.00
Insertion loss: measurement antenna attenuator (if present)	0.00
Base station simulator: absolute/relative level	See Appendix G.5
Antenna: gain of the measurement antenna	0.00
Measurement distance: <ul style="list-style-type: none"> • offset of EUT phase center from center of rotation • 'blocking' effect of EUT on measurement antenna <ul style="list-style-type: none"> - VSWR - Chamber standing wave • phase curvature across the EUT 	0.00
Signal level ripple within quiet zone	0.00
Influence of the ambient temperature on the radiated sensitivity of the test equipment	0.00
EUT repositioning uncertainty	See Appendix G.21
Miscellaneous uncertainty	See Appendix G.13
Uncertainty due to difference in gain of the test antenna over the different channel bandwidths	See Appendix G.20

Calculation of absolute uncertainty for TIS calculated using a relative single-point/multi-point radiated measurement:

The non-zero uncertainty values in the table above shall be combined by root-sum-squares to produce:

u_c TIS relative measurement

The overall uncertainty for the measurement is then:

$$u_c = \sqrt{u_{c \text{ TIS relative measurement}}^2 + u_{c \text{ full TIS measurement}}^2}$$

From this, the expanded uncertainty, *U*, is calculated as $U = 2 \cdot u_c$ for a 95% confidence level.

This is the resulting value of the TIS expanded uncertainty for the measurement and should be stated in the results sheet.

7.5 Criteria—Measurement Uncertainty

The results of the calculations for expanded uncertainty for both TRP and TIS measurements shall be reported, along with full documentation to support the resulting values. The test performance requirements shall not be adjusted by the measurement uncertainty when determining compliance of the EUTs.

The expanded TRP and TIS uncertainties must not exceed the values in [Table 7-8](#) at a 95% confidence level.

TABLE 7-8 EXPANDED UNCERTAINTY MAXIMUM LIMITS FOR DIFFERENT CONFIGURATIONS FOR TRP AND TIS

Expanded Uncertainty (dB)				
Test Configuration	TRP (f ≤ 3GHz)	TRP (3GHz < f ≤ 6GHz)	TIS (f ≤ 3 GHz)	TIS (3GHz < f ≤ 6GHz)
Free Space	2	2.3	2.3	2.6
Beside Head and Hand Left and Beside Head and Hand Right	2.4	2.7	2.6	2.9
Hand Left and Hand Right	2.2	2.5	2.4	2.7
Wrist-worn Left and Wrist-worn Right	2.2	2.5	2.4	2.7
Additional MU allowance for 50cm quiet zone	0	0.3	0	0.3
Additional MU allowance for “alternate” method	0	0.3	0	0.3

Appendix A Test Set-up Configurations (Normative)

This appendix defines the required orientation of the EUT and any required phantoms relative to a Cartesian (XYZ) coordinate system and illustrates the starting orientation of that coordinate system for the typical spherical measurement systems (distributed or combined axes). It also includes schematics of typical instrumentation configurations. Alternate setups are allowed as long as they meet the criteria specified in this Test Plan and any additional uncertainty contributions are accounted for. The general requirement is that the test setup be capable of holding the EUT both in free space and with head/hand phantoms (see [Appendix C](#)). The performance of the test site must be determined as detailed in [Section 3](#).

A.1 Positioning Requirements and Coordinate Systems

The test system must be capable of holding the EUT and any associated head/hand phantoms (defined in [Appendix C](#)). The hardware and positioners used to accomplish this must be made of low dielectric material (dielectric constant less than 5.0 and a loss tangent less than 0.05) so as to produce a minimal impact on overall measurement uncertainty. The measurement uncertainty due to any components not included in the ripple test shall be assessed according to [Appendix G](#). As the EUT will be held in multiple configurations (free space, head and hand phantom [left and right], hand phantom only [left and right]), considerable care must be given to the design and implementation of the EUT holding fixtures so as to meet all of these requirements.

All of the fixtures and tools referenced shall be fabricated using the CAD files obtained from CTIA Certification. Contact cpwg@ctiacertification.org to obtain CAD files.

While different spherical measurement systems may require a different starting orientation of the EUT, the relative coordinate system for the EUT and head/hand phantoms shall remain the same independent of test site implementation.

The following subsections detail the positioning requirements and coordinate systems for the various required test configurations.

A.1.1 Free-Space

The “free-space” position and coordinate system are defined as follows:

1. Ready the EUT for operation, if necessary.
2. Define two imaginary lines on the EUT: the vertical centerline and the horizontal line. The vertical centerline passes through two points on the front side of the EUT: the midpoint of the width w_t of the EUT at the level of the earpiece (point A on [Figure A-1](#)), and the midpoint of the width w_b of the bottom of the EUT (point B). The horizontal line is perpendicular to the vertical centerline and passes through the center of the earpiece (see [Figure A-1](#)). The two lines intersect at point A. Note that for many EUT's, point A coincides with the center of the earpiece, however, the earpiece may be located elsewhere on the horizontal line. Also note that the vertical centerline is not necessarily parallel to the front face of the EUT (see [Figure A-1](#)), especially for fold EUT's, EUT's with flip pieces, and other irregularly-shaped EUT's.
3. Define a Cartesian coordinate system with the origin at point A, where the positive z-axis is along the line from B to A, the positive Y-axis is along the horizontal line and points to the

“right” of the phone face, and the positive X-axis is orthogonal to the Y-Z plane and points away from the face of the phone. Figure A-2 illustrates this coordinate system definition for three typical case styles of EUT. In all cases, the longitudinal direction of the EUT is the Z-axis, and the right hand rule is used to define the X- and Y-axes.

FIGURE A-1 EUT VERTICAL AND HORIZONTAL REFERENCE LINES

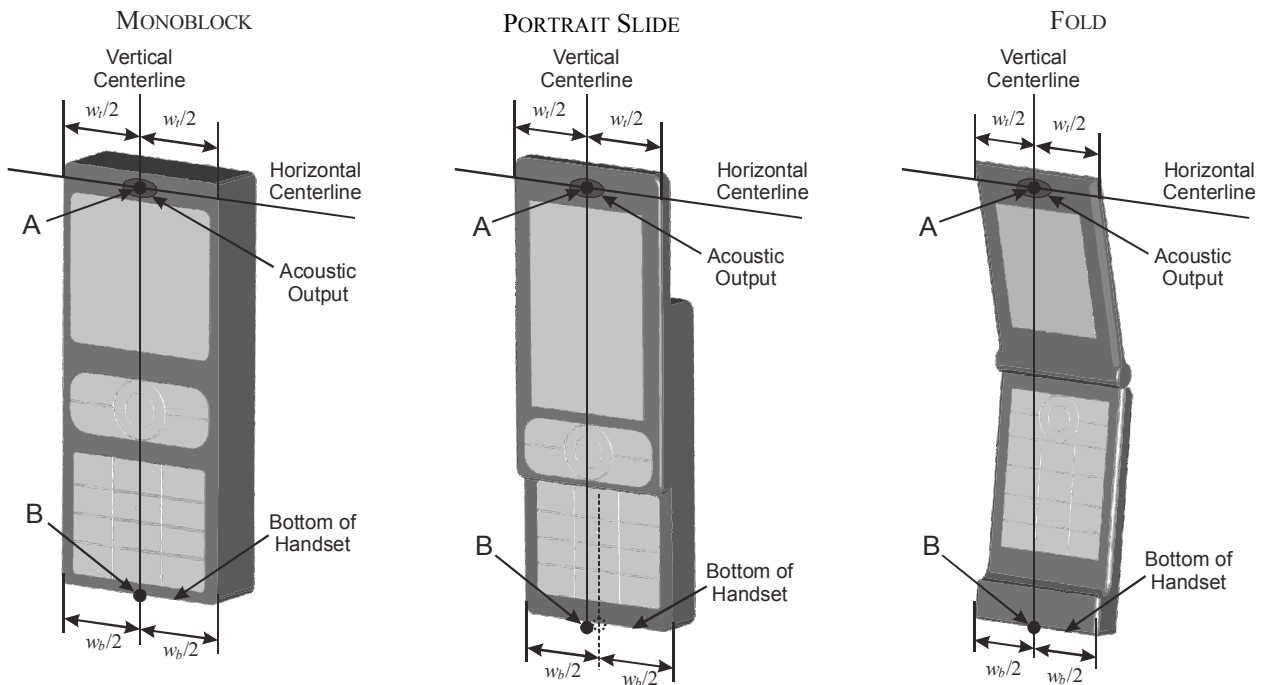
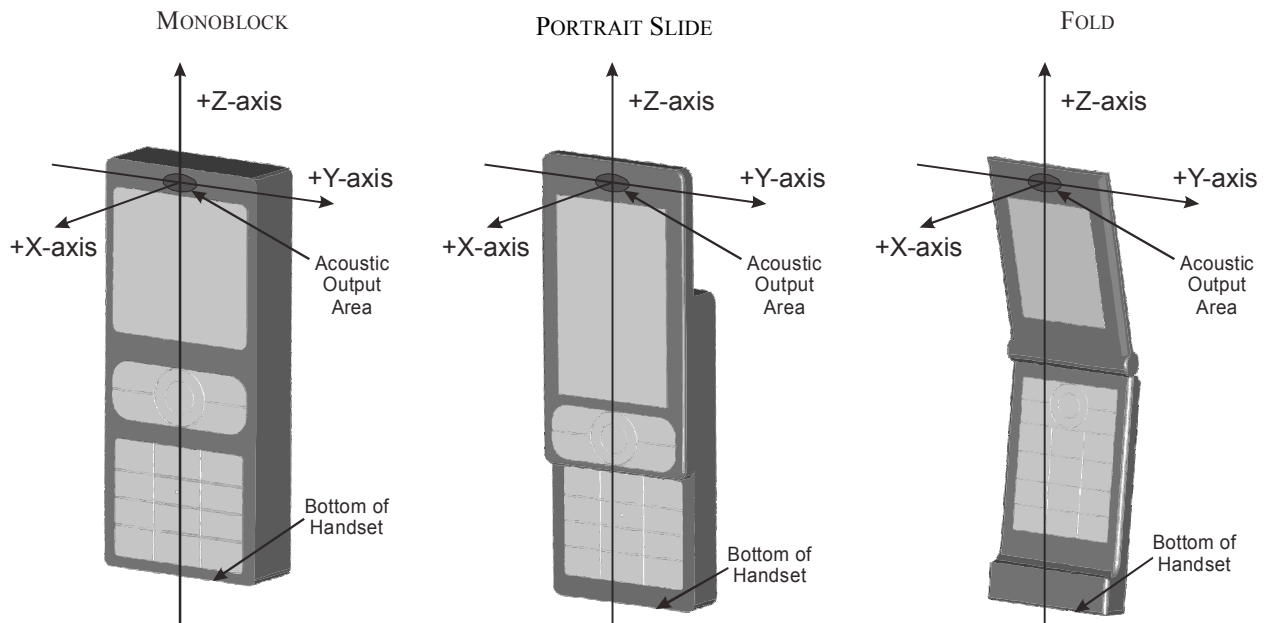

FIGURE A-2 EUT COORDINATE SYSTEM - FREE SPACE



Note that monoblock EUTs are also referred to as candy bar phones. Fold EUTs are also referred to as clam shell phones.

A.1.2 Head Phantom Only

The head phantom only configuration is used to simulate talk position, in cases for which no standard hand phantom is available (see A.1.3).

The EUT shall be mounted in “cheek” position [2] on the head phantom. This position and its coordinate system are defined as follows:

1. Follow steps 1 and 2 from [Appendix A.1.1](#).
2. [Figure A-3](#) shows the profile of the SAM head phantom. Indicated are the locations of the right ear (RE) point and the mouth (M). The corresponding left ear point (LE) being on the head phantom's corresponding left side. Position the EUT close to the surface of the SAM head phantom such that point A is on the (virtual) extension of the line passing through points RE and LE on the head phantom (see [Figure A-4](#)), and so that the plane defined by the vertical center and the horizontal line of the phone is approximately parallel to the sagittal plane of the head phantom.
3. Translate the EUT towards the head phantom along the line passing through RE and LE until the EUT touches the ear.
4. While maintaining the EUT in this plane, rotate it around the LE-RE line until the vertical centerline is in the plane normal to MB-NF including the line MB (called the reference plane).
5. Rotate the EUT around the vertical centerline until the phone (horizontal line) is symmetrical with respect to the line NF.

6. While maintaining the vertical centerline in the reference plane, keeping point A on the line passing through RE and LE and maintaining the EUT contact with the ear, rotate the EUT about the line NF until any point on the EUT is in contact with a head phantom point below the ear (cheek). See [Figure A-4](#).
7. Define a Cartesian coordinate system with the origin at point A (RE or LE), where the positive Z-axis is perpendicular to the top of the SAM head phantom, the positive X-axis pointing away from the face of the phantom, and the positive Y-axis along the RE-LE line in the LE direction. [Figure A-5](#) illustrates this coordinate system definition both the right and left ears. As an alternative, the origin of the coordinate system may be moved along the Y-axis while maintaining the orientation of the coordinate system such that the X-Z plane is in the center of the phantom as illustrated in [Figure A-6](#), provided the uncertainty contribution in [Appendix G.7.1](#) is applied.

FIGURE A-3 SAM HEAD PHANTOM WITH MOUTH AND EAR LOCATIONS

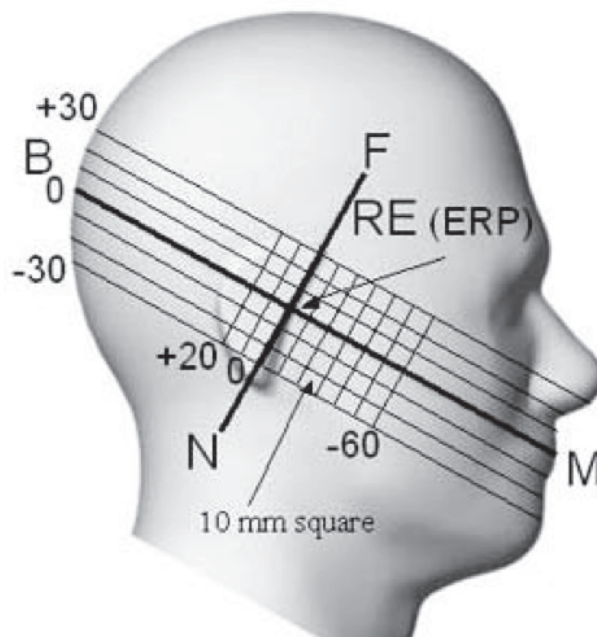

FIGURE A-4 EUT POSITION: "CHEEK" OR "TOUCH" POSITIONS FOR RIGHT EAR

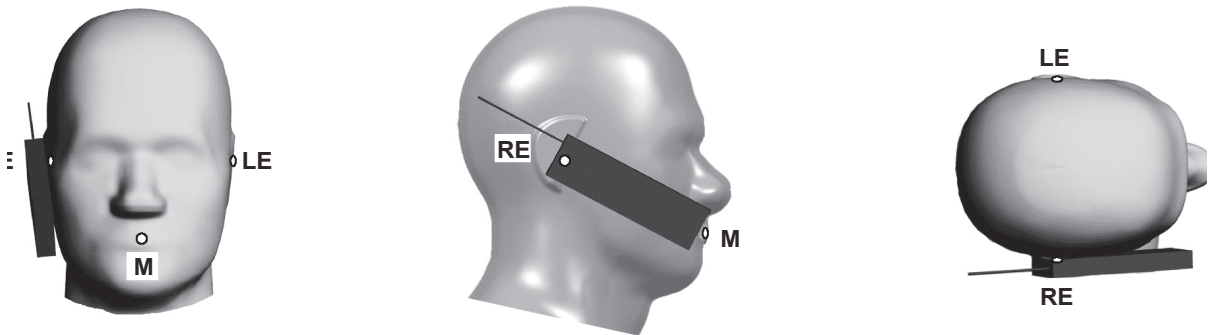

FIGURE A-5 DEFINITION OF COORDINATE SYSTEM FOR SAM HEAD PHANTOM

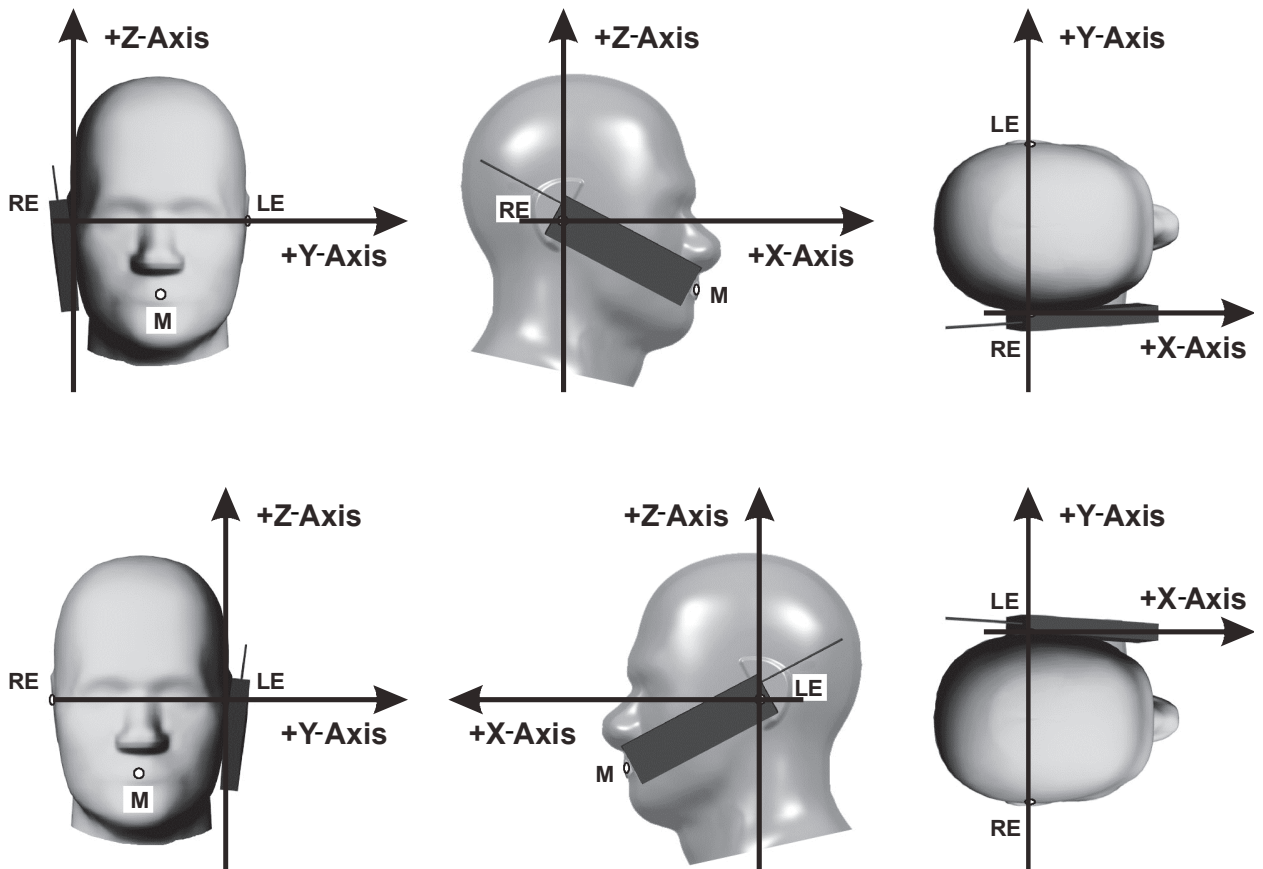
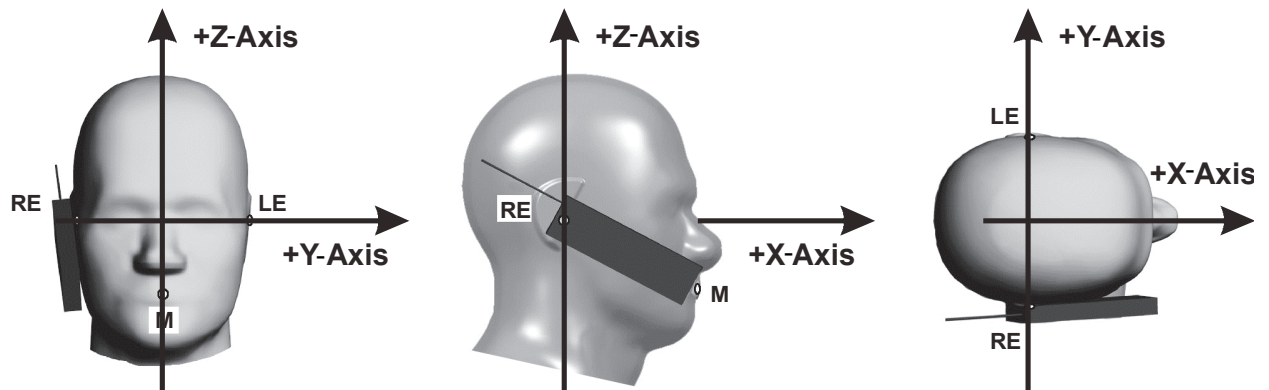

FIGURE A-6 ALTERNATE COORDINATE SYSTEM FOR SAM HEAD PHANTOM



A.1.3 Hand Phantom Selection

If available (for EUT dimensions and form factor), an appropriate standard hand phantom shall be employed when testing the “talk” (head-and-hand, voice call) and “data” (hand-only, browsing) modes.

Figure A-7 illustrates a flowchart for selecting the appropriate hand phantom for a given EUT. If the device exceeds 72 mm but does not exceed 92 mm in width, then the Wide Grip shall be used for testing both “talk” and “data” modes. If the device width is between 56 mm and 72 mm (inclusive), then the PDA Grip shall be used for both modes. If the device is less than 56 mm in width, then “data” (hand-only) mode will be tested in the Narrow Data Grip, and the hand phantom used for testing “talk” mode (against the head) is determined by form factor: monoblock and closed slide/rotator EUT use the Monoblock Grip, while fold and open slide/rotator EUT use the Fold Grip.

Devices not fitting aforementioned criteria (e.g., devices wider than 92 mm, those held in a landscape orientation or with two hands) are not required to be tested with a hand phantom under this Test Plan at this time.

Network operators or other customers may request additional testing with non-standard hand phantoms. In such cases, standard fixturing and positioning is to be observed to the extent possible, and the additional data can be included and marked as supplemental in the test report.

FIGURE A-7 Choosing the Correct Hand Phantom

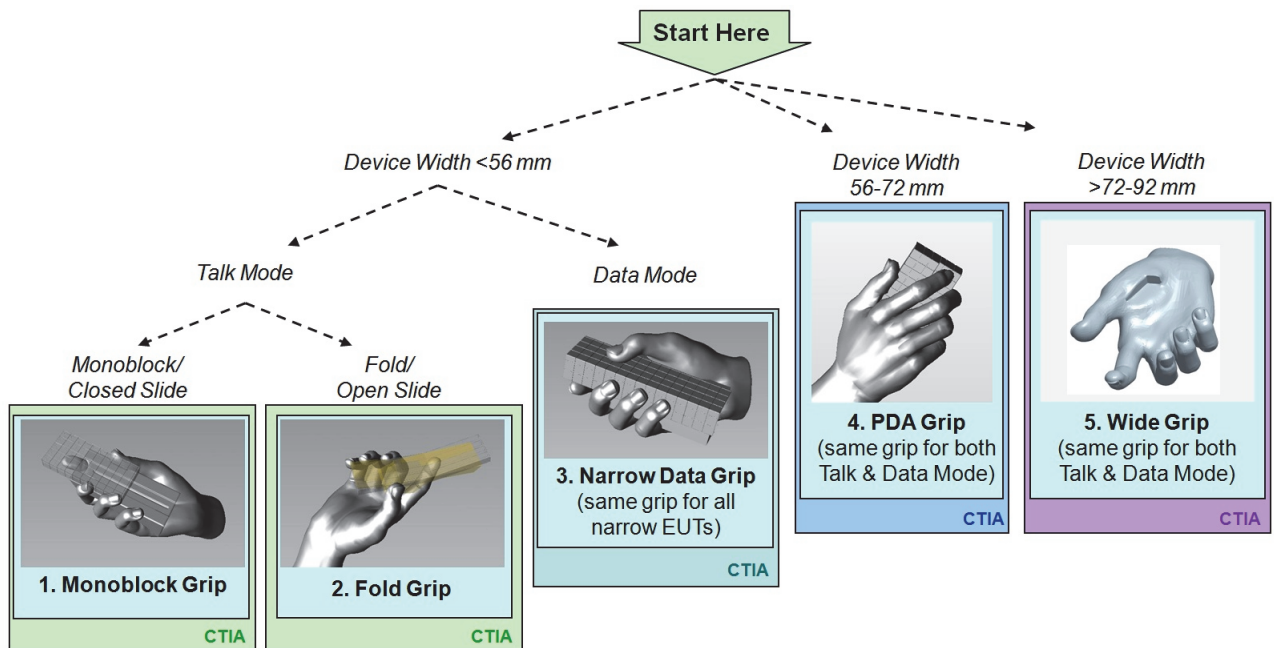

A.1.4 Head and Hand Phantom (“Talk Mode”)

The head and hand phantom configuration is used to simulate the same “talk mode” of operation as the head-only configuration of [Appendix A.1.2](#), but is intended to be more realistically representative because it also includes the hand. Additionally, the head and hand “talk mode” configuration specifies that the EUT not be in direct physical contact with the cheek of the head phantom, but rather, tilted away from the cheek by an angle of 6°. This “six degrees from touch position” is based on user studies and is intended to more realistically represent real-world operation of the EUT.

Standard positioning of the EUT in the hand phantom varies with the choice of hand phantom being used. The choice of hand phantom for a given EUT is defined in the preceding [Appendix A.1.3](#). The positioning of the EUT in each type of hand phantom is defined in the subsequent subsections, [Appendix A.1.4.1](#) through [A.1.4.3](#).

Positioning of the combined hand+EUT against the head is analogous to the positioning of the EUT for the head-only configuration of [A.1.2](#), with the exception that the 6° tilt angle from the cheek is used instead of direct contact with the cheek of the head phantom. The same coordinate system and reference points previously defined on the head phantom and EUT are used. The alternate coordinate system shown in [Figure A-6](#) may be used if the additional ripple test according to [Section 3.6](#) has been performed and the results are included in the uncertainty calculation.

Finding the correct “6° from touch” position against the head phantom may be difficult while the EUT is in the grasp of the hand phantom - in particular, the fingertips of the hand phantom may extend beyond the face of a thin EUT and act as an obstruction. An optional mask spacer is available for the head phantom, to assist with locating and maintaining the EUT in the desired “6° from touch” position. The mask is a 32 mm wide conformal strip, created by sweeping the surface of the head phantom through a 6° rotation

about the ear. Direct EUT contact against the mask thus establishes the required 6° spacing away from the head, regardless of EUT form factor. The material for the head phantom mask spacer shall be solid with a dielectric constant of less than 1.3 and a loss tangent of less than 0.003. Material additions around the nose, mouth, or opposite side of the head phantom may help to fix the mask spacer onto the head phantom.

In the situation where the fingertips of the hand phantom obstruct the EUT from touching the mask in the cheek region, then the hand+EUT will be rotated beyond 6° such that the fingertips just touch the head phantom.

FIGURE A-8 OPTIONAL HEAD PHANTOM MASK SPACER ON SAM HEAD PHANTOM

(a) Right-sided positioning of the mask spacer

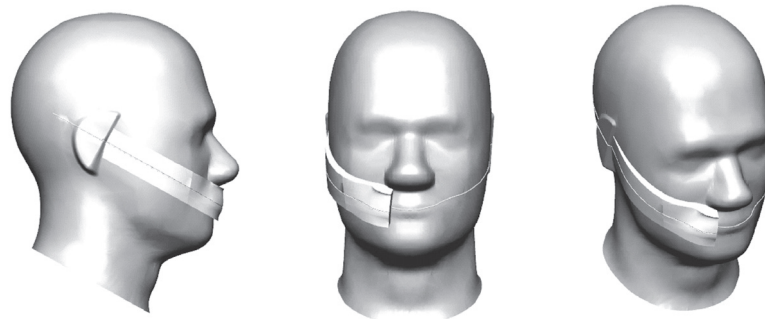

(b) Left-sided positioning of the mask spacer

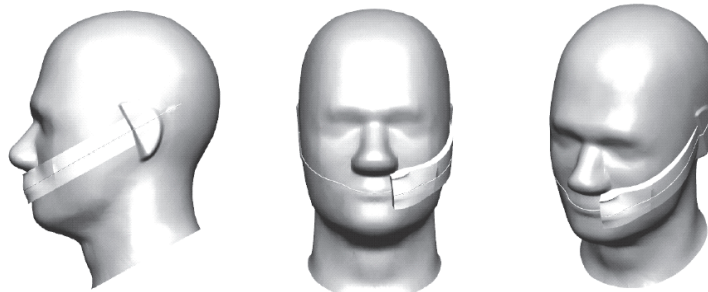

The EUT shall be mounted in a suitable hand phantom and placed in a tilted position (cheek + 6 degrees) on the head phantom.

1. Ready the EUT for operation, if necessary.
2. Mount the EUT onto the palm spacer and place it in the hand phantom, as defined in the appropriate subsequent subsection (A.1.4.1 through A.1.4.3 for the type of hand phantom being used. This subassembly of hand phantom, palm spacer and EUT is now referred to as the "hand+EUT."
3. If the optional 6 degree head phantom mask spacer will be used, then affix it to the head phantom as shown in [Figure A-8](#) utilizing the appropriate right-sided or left-sided configuration.

4. Orient the hand+EUT so that the EUT is facing the head phantom with its vertical (longitudinal) centerline aligned in the reference plane (as indicated by an engraved line passing through the ears and mouth of the head phantom) and its acoustic output oriented toward the ear.
5. If necessary, rotate the hand+EUT around the vertical centerline of the EUT so that its contacting edge at the acoustic output is parallel to the flat plane of the ear on the head phantom. Note that the flat ear surfaces of the head phantom are not vertical but rather tapered slightly inward at the bottom.
6. While keeping the EUT vertical centerline aligned with the reference plane marking on the head phantom, translate the hand+EUT toward the head phantom until the EUT makes a flat, two-point contact with the ear. The horizontal line passing through the acoustic output of the EUT (as defined in [A.1.1](#)) should be aligned with the perpendicular NF line marking that crosses through the ear.
7. Rotate the hand+EUT about the ear axis (i.e., the perpendicular NF line) until any third point on the EUT makes physical contact. If the device is thin and the mask spacer is not being used, it may be necessary to bend away the flexible fingers of the hand phantom to allow contact between the head phantom and the EUT without obstruction. If the head phantom mask spacer is used, rotate the hand+EUT about the ear axis (i.e., the perpendicular NF line) until any third point of the hand+EUT makes physical contact with either the head phantom mask spacer or the surface of the head phantom itself.
8. If the mask spacer is not being used, then it is necessary to again rotate the hand+EUT about the ear axis (i.e., the perpendicular NF line) back away from the head phantom by 6 degrees from the three-point touch position. If the fingers of the hand phantom were bent to allow contact between the head phantom and the EUT without obstruction, then they shall be moved back to their proper positions. If it is not possible to reposition the fingers due to interference with the head phantom, then the EUT shall be rotated further away from the head until the fingers, when positioned correctly, just touch the head phantom.

The assembled head and hand configuration is shown in [Figure A-9](#), for an example EUT tested with the monoblock hand phantom and palm spacer in both right-sided and left-sided configurations.

The tolerance on the tilt angle specified in step 7 or 8 must be within $\pm 2^\circ$. The tilt angle tolerance using the mask spacer shall be assessed by the ATL or the tilt angle shall be able to be measured using a scale that is an integral part of the fixturing or with a suitable gauge. The tilt angle r_2 is defined in [Figure G-6](#).

[Table G-4](#) gives an example of the uncertainty assessment for EUT positioning using a value for r_2 (deg) of $\pm 0.5^\circ$. The actual angular uncertainty for r_2 shall be used to calculate the EUT positioning measurement uncertainty.

FIGURE A-9 HEAD AND HAND CONFIGURATION (A) WITH AND (B) WITHOUT MASK SPACER (RIGHT), (C) WITH AND (D) WITHOUT MASK SPACER (LEFT)

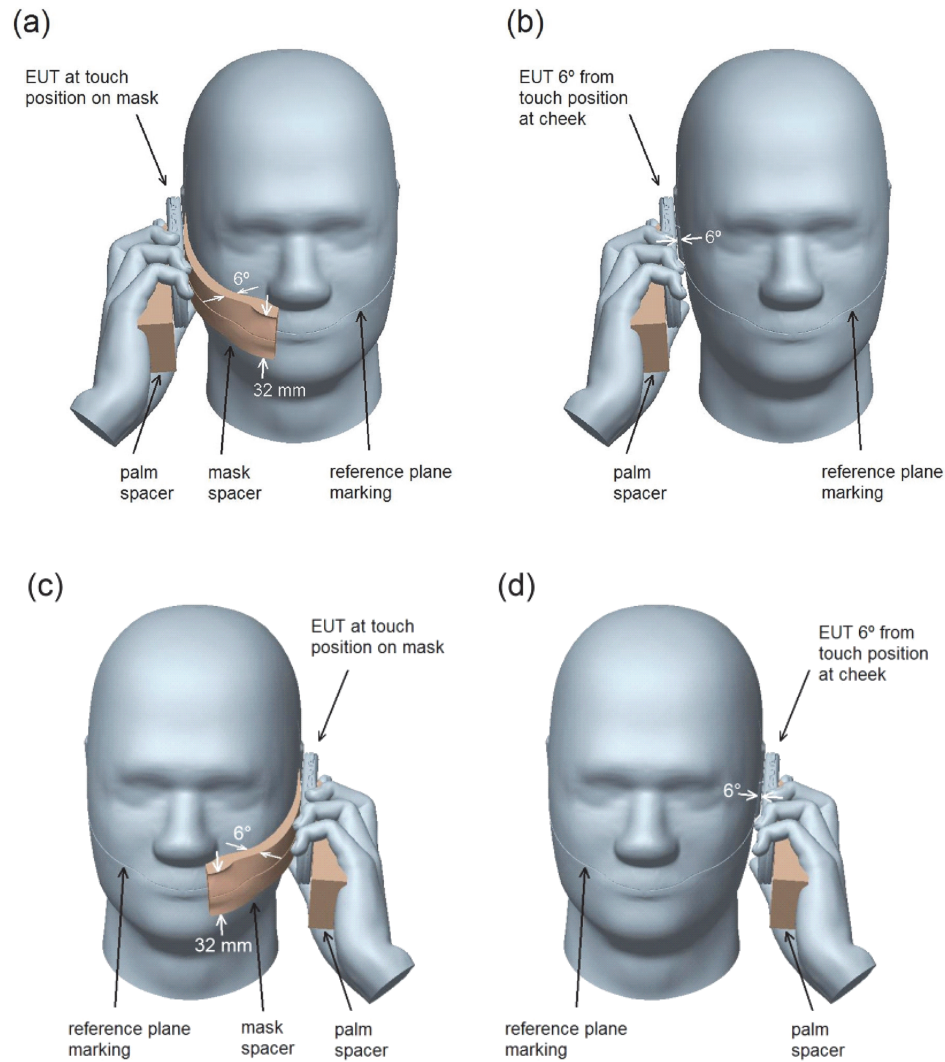

A.1.4.1 Mounting Monoblock EUT in Monoblock Hand Phantom for Talk Mode

This procedure applies to mounting monoblock EUTs, closed portrait slide EUTs and closed rotator EUTs, when the EUT is less than 56 mm wide.

User grip studies indicate that the average grip for this type of EUT has the index finger pressing against the back, the ring finger in contact with the EUT at the bottom, and the pinky finger not touching the EUT. To help maintain a consistent, repeatable positioning that conforms to the grip studies, an alignment tool with evenly spaced rulings is first used to measure the EUT. The EUT is then positioned in accordance with ruled markings on a conformal palm spacer. Alignment Tool A (see [Figure A-10](#)) features a 120°

interior corner to help ensure that the ring fingertip lands in the desired position at the bottom of the EUT, regardless of any curvature in the EUT corners. There are two ruled scales: a bottom ruler (measuring down from the 120° corner) and a side ruler (measuring up from the 120° corner). The EUT is placed so as to fit into the 120° corner and is measured from the bottom ruler. EUTs with rounded corners will sit lower in the tool than EUTs having square corners, and thus give a different reading.

1. Place the EUT face-up in Alignment Tool A with its side along the side ruler, and slide it down until it makes contact at the 120° corner as shown in [Figure A-10](#).
2. Measure and record the bottom of the EUT by reading off the bottom ruler of Tool A.
3. Observe the top of the EUT against the side ruler of the tool. If the top of the EUT extends past the 120 mm marking on the side ruler, then the additional length beyond 120 mm shall be added to the reading from step 2.
4. Position the EUT on the monoblock palm spacer ([Figure A-11](#)). The vertical centerlines of the EUT and the palm spacer shall be superposed. The bottom of the EUT shall be lined up with the ruled marking on the palm spacer that corresponds to the reading from the alignment tool, as determined in steps 2 and 3. The EUT may optionally be affixed to the palm spacer with the help of touch fastener material.
5. Position the conformal palm spacer, with EUT, into the grasp of the monoblock hand phantom. Ensure that the index fingertip contacts the back of the EUT and the ring finger contacts the side of the EUT near its bottom.

FIGURE A-10 Alignment Tool A

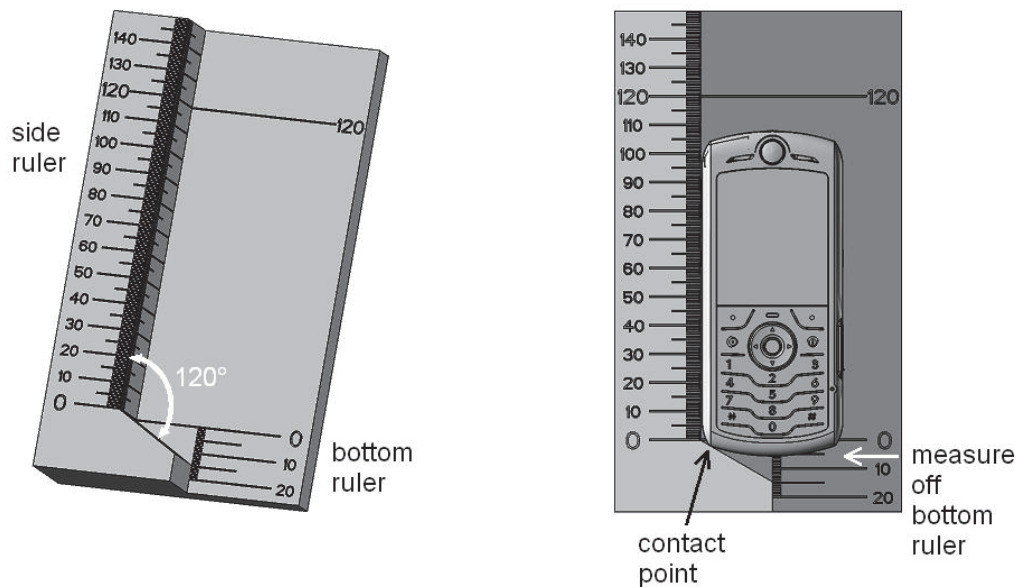

The material for the monoblock palm spacer shall be hollow with a wall thickness less than 2 mm, and a dielectric constant of less than 5.0 and a loss tangent of less than 0.05 or it shall be solid with a dielectric constant of less than 1.3 and a loss tangent of less than 0.003. It may feature an optional groove or cavity to accommodate touch fastener material.

FIGURE A-11 MONOBLOCK PALM SPACER

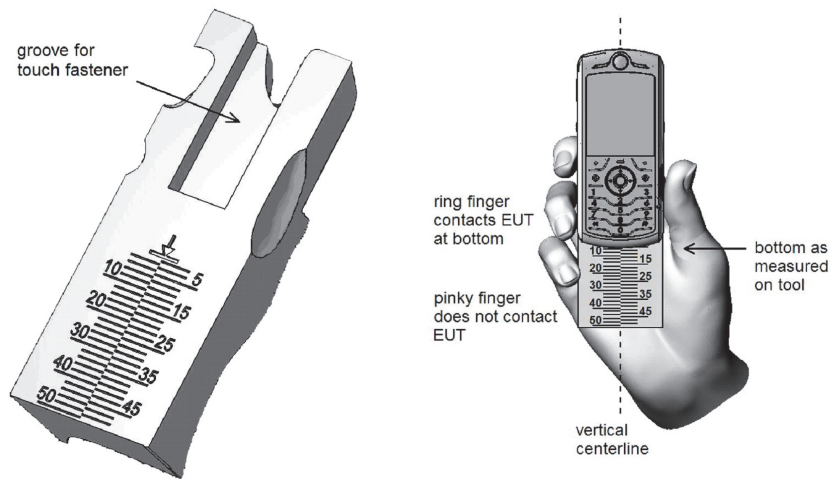

Note: A mirror-image configuration of the palm spacer shall be used for the left-handed monoblock grip.

A.1.4.2 Mounting Fold EUT in Fold Hand Phantom for Talk Mode

This procedure applies to fold and open portrait slide/rotator EUTs when the EUT is less than 56 mm wide.

User grip studies indicate that the average grip for this type of EUT has the index finger pressing against the back of the flip above the hinge, and the thumb and remaining fingers gripping the base below the hinge. To help maintain a consistent, repeatable positioning that conforms to the grip studies, an alignment tool with evenly spaced rulings is first used to measure the EUT. The EUT is then positioned in accordance with ruled markings on a conformal palm spacer. Alignment Tool B (see [Figure A-12](#)) features two rounded humps upon which the EUT is suspended. One hump represents the index fingertip of the hand phantom, while the other represents the palm spacer. This design helps ensure that the index finger remains in contact with the flip for any fold EUT geometry, regardless of hinge position or fold angle. The tool also features a line marking along its side wall, for aligning the EUT hinge axis of rotation for consistent positioning. The ruled scale for measuring the bottom of the EUT is split-level in order to minimize parallax discrepancies when measuring EUTs that are suspended above the ruler by their fold angle.

1. Open the EUT and rest it face-up on Alignment Tool B with its hinge suspended between the two humps, as shown in [Figure A-12](#) and [Figure A-13](#). The side of the EUT shall be aligned against the side wall of the tool. The base of the EUT shall rest on the wide hump with ruled markings, and the flip of the EUT shall rest on the narrow hump.
2. If a fold EUT, then slide the EUT longitudinally so as to align its hinge axis of rotation with the line marking engraved on the side wall of the tool, as closely as possible such that the EUT is not physically lifted off from either hump of the tool ([Figure A-12](#)). If an open portrait slide or rotator EUT, then slide the EUT longitudinally until the base part of the EUT touches the narrow hump of the tool ([Figure A-13](#)).
3. Measure and record the bottom of the EUT by reading off the bottom ruler of Tool B. Visually align the two halves of the split-level ruler to minimize parallax reading error.

4. Position the conformal fold palm spacer (Figure A-14) in the fold hand phantom corresponding to the right-handed or left-handed configuration.
5. Position the EUT in the Fold Hand Phantom, resting on the index fingertip and palm spacer, with the bottom of the EUT aligned to the ruling on the palm spacer that corresponds to the reading from step 3. Ensure that all fingertips are in contact with the EUT. Touch fastener material may be used to affix the EUT to the palm spacer.

FIGURE A-12 ALIGNMENT TOOL B AND USAGE WITH FOLD EUT

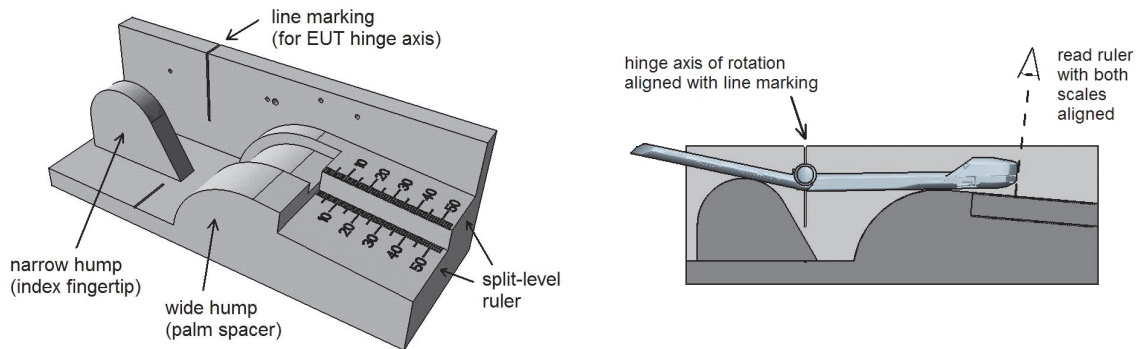
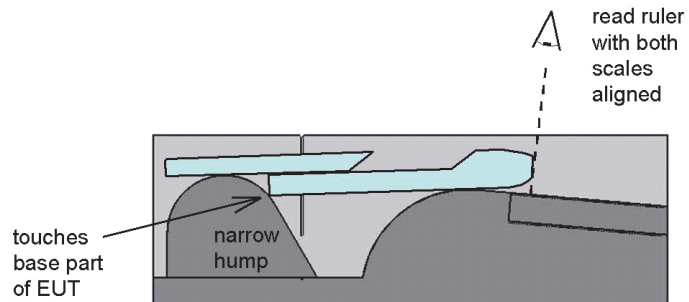
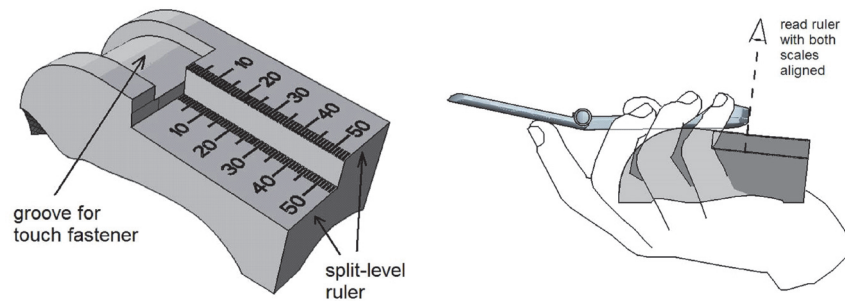

FIGURE A-13 USAGE OF ALIGNMENT TOOL B WITH OPEN PORTRAIT SLIDE EUT



The material for the fold palm spacer shall be hollow with a wall thickness less than 2 mm, and a dielectric constant of less than 5.0 and a loss tangent of less than 0.05 or it shall be solid with a dielectric constant of less than 1.3 and a loss tangent of less than 0.003. It features a split-level ruler to avoid parallax errors, and a groove to accommodate touch fastener material.

FIGURE A-14 FOLD PALM SPACER



Note: A mirror-image configuration of the palm spacer shall be used for the left-handed fold grip.

A.1.4.3 Mounting Wide EUT in PDA Hand Phantom for Talk Mode

This procedure applies to EUTs 56 to 72 mm wide, for talk position.

User grip studies have shown that the average grip for this type of EUT has the index finger pressing against the back near the top and the thumb at the side. To help achieve a consistent positioning that conforms to the grip studies, the EUT is aligned to the PDA palm spacer (Figure A-15). No alignment tool is required. The PDA spacer features side and bottom walls to help ensure consistent alignment of EUTs of various sizes.

1. Place the EUT on the PDA spacer (see Figure A-15).
2. Align the EUT to the side wall of the PDA (see Figure A-16).
3. If the EUT is shorter than 135 mm, then align the top of the EUT with the top of the PDA spacer as shown in Figure A-16. Otherwise, align the bottom of the EUT with the bottom wall of the PDA spacer.

The material for the PDA palm spacer shall be hollow with a wall thickness less than 2 mm, and a dielectric constant of less than 5.0 and a loss tangent of less than 0.05 or it shall be solid with a dielectric constant of less than 1.3 and a loss tangent of less than 0.003. It may feature a groove or cavity to accommodate touch fastener material.

FIGURE A-15 PDA PALM SPACER

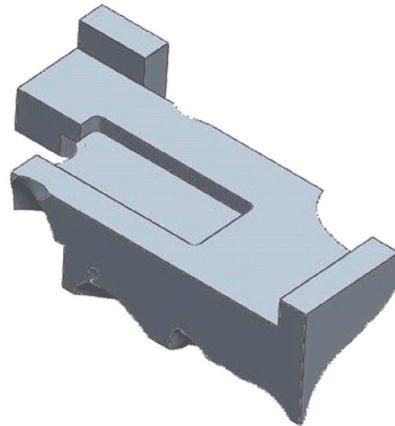

Note: A mirror-image configuration of the palm spacer shall be used for the left-handed grip.

FIGURE A-16 POSITIONING OF WIDE EUT WITH RESPECT TO PDA PALM SPACER

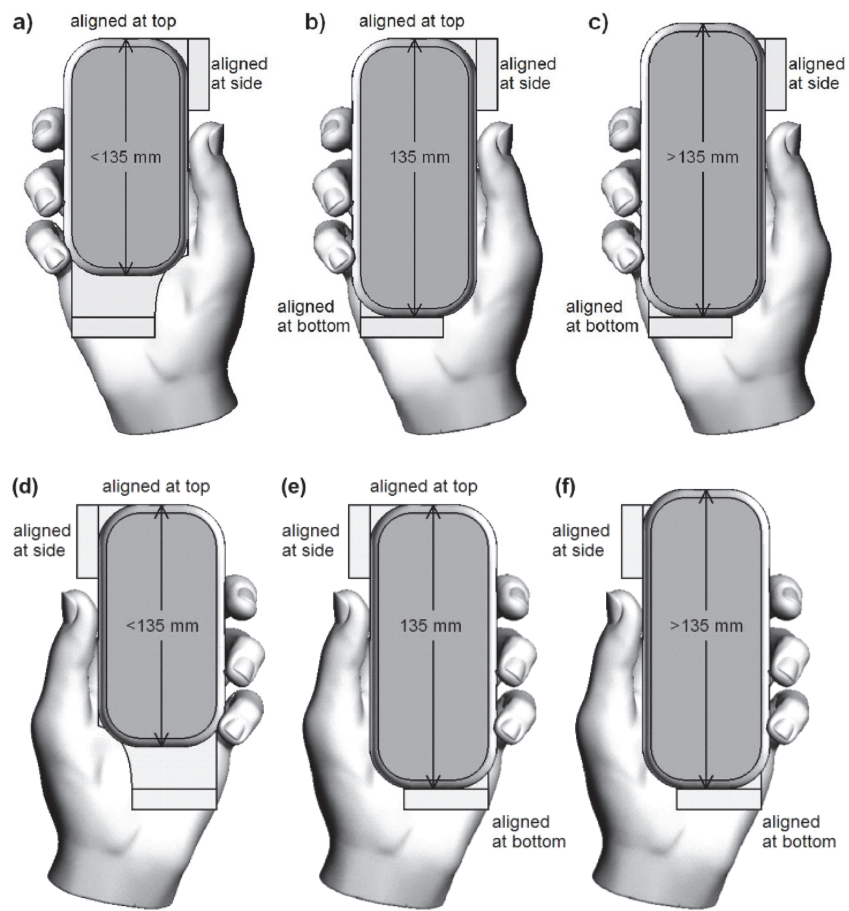

A.1.4.4 Mounting a Wide EUT in the Wide Grip Hand Phantom for Talk Mode

This procedure applies to EUTs exceeding 72 mm but not 92 mm in width.

The Wide Grip hand phantom features an angular palm cutout at the base of its thumb, featuring two flat wall surfaces for contacting the EUT at its corner. The conformal palm spacer for the Wide Grip includes an additional wall support at its side, near the thumb. The corner of the EUT shall be fitted into the phantom palm cutout so that physical contact is maintained with each of its two flat walls, with the palm spacer wall support near the thumb, and with the deflected thumb itself, as shown in [Figure A-17](#).

FIGURE A-17 WIDE GRIP HAND PHANTOM CONTACT POINTS

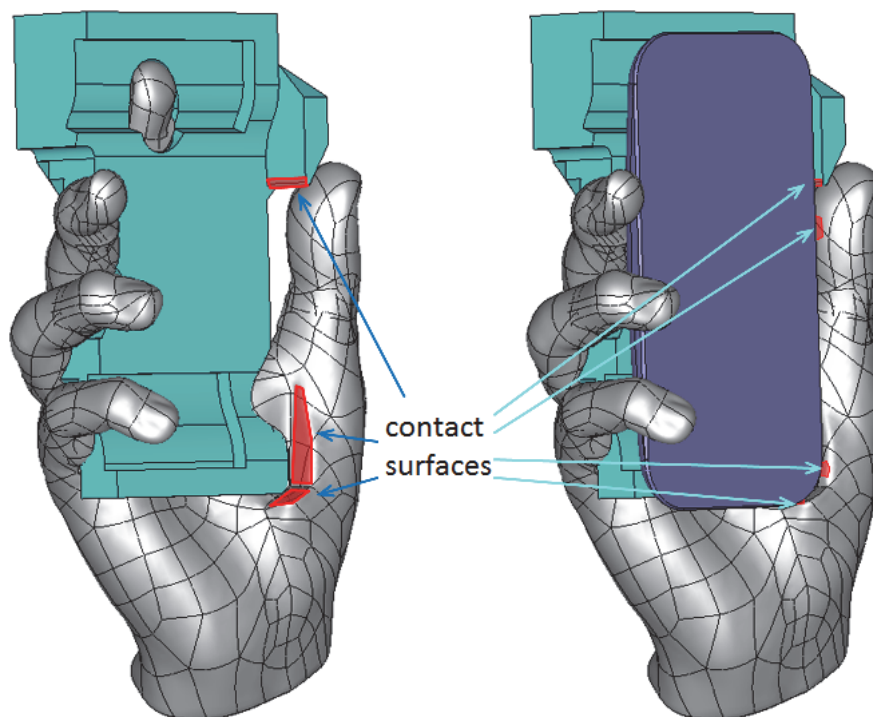

Additionally, the EUT shall be affixed or otherwise contacted to rounded surfaces of the conformal palm spacer ([Figure A-18](#)), e.g., with heavy duty touch fastener.

FIGURE A-18 WIDE GRIP PALM SPACER CONTACT SURFACES

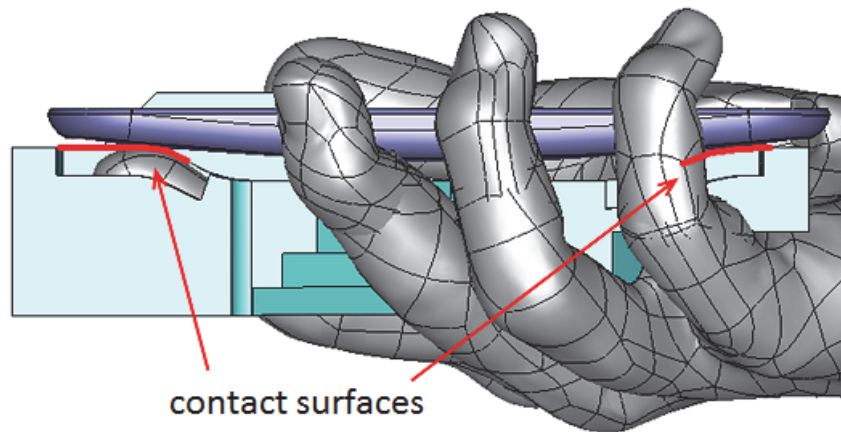

If the EUT features a protruding side key in a location around its perimeter that could cause unintended actuation during OTA measurements by the structure of the hand phantom or the palm spacer, then a grommet can be added to prevent actuation (Figure A-19). Grommets shall be made of insulating material, and have the minimum thickness and dimensions required to prevent actuation of the side key.

FIGURE A-19 INSULATING GROMMET TO PREVENT SIDE KEY ACTUATION

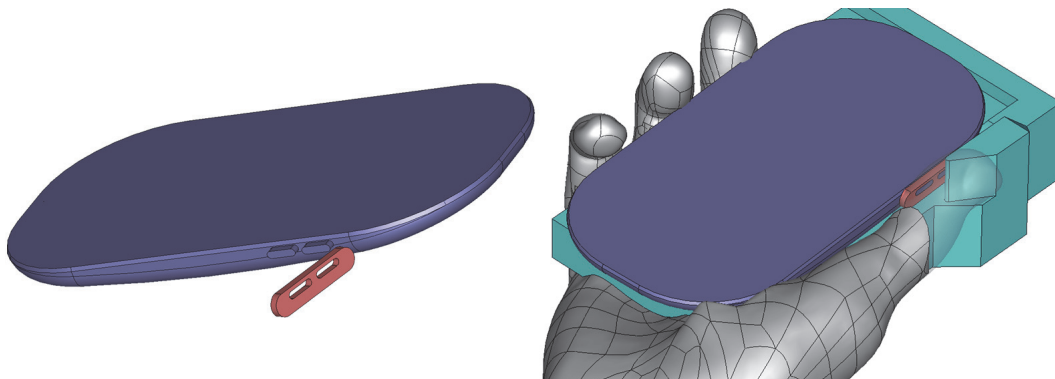

A combination of rounded EUT corner geometry, side keys and/or grommets may cause the longitudinal axis of the positioned EUT to be misaligned from the longitudinal axis of the palm spacer (and other fixturing elements) by an angle $r1'$ (Figure A-20). This may cause the EUT to be misaligned from the MB reference plane of the head phantom (Figure A-3) by the same angle, for "talk" mode (head-and-hand) measurements. In such cases, the palm spacer shall remain longitudinally aligned to the MB reference plane, and the earpiece of the EUT shall remain positioned with reference to the left and right ear reference points as described in Appendix A.1.4. The systematic angle between the EUT and palm spacer longitudinal axes $r1'$ need not be included in the angle $r1$ for calculating measurement uncertainty as described in Appendix G.10.5.2. Rather, angle $r1$ from the MB reference plane of the head phantom shall be evaluated with respect to the longitudinal axis of the Wide Grip palm spacer.

FIGURE A-20 WIDE GRIP EUT POSITIONING EXAMPLE WITH ROUNDED CORNER, SIDE KEY GROMMET

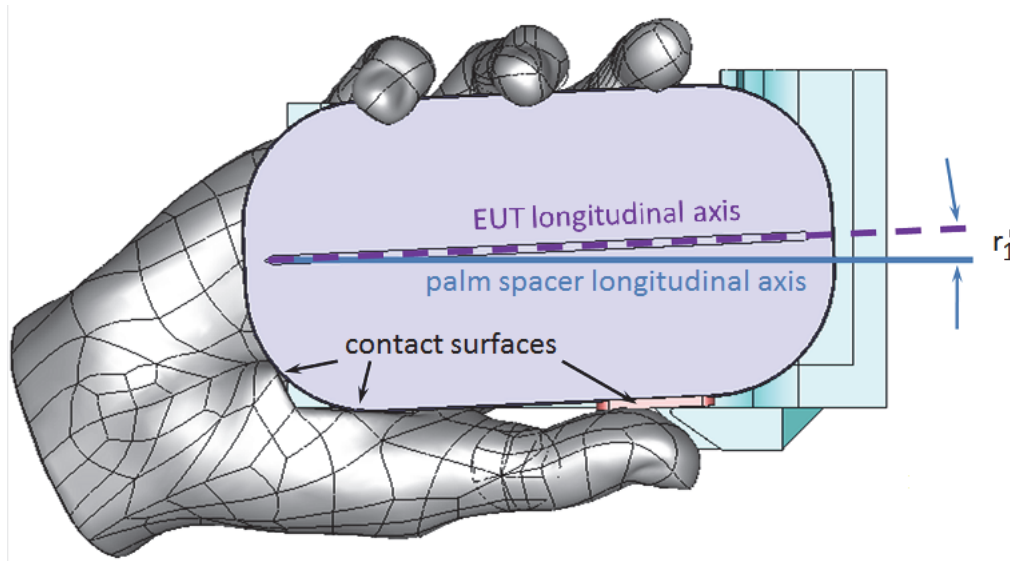

A.1.5 Hand Phantom Only

The hand phantom only configuration is used to simulate data mode (browsing, navigation).

The EUT shall be mounted in a suitable hand phantom and oriented such that the EUT's main display is tilted $45 \text{ degrees} \pm 5 \text{ degrees}$ from vertical.

1. Ready the EUT for operation, if necessary. For example, for devices with a cover piece, open the cover.
2. Mount the EUT in the hand (refer to the following subsections)
3. Define a line L that is normal to the plane of the main display and passes through its center. Define a line M that lies within the plane of the main display, intersecting L, and lies parallel to the horizontal axis of the display. See [Figure A-21](#).
4. Define a Cartesian coordinate system with its origin at the L-M intersection, where the positive Y-axis lies along M pointing to the right of the phone. Define the positive X-axis to face away from the display at an angle 45 degrees "below" line L and the positive Z-axis to face away from the display 45 degrees "above" line L, as illustrated in [Figure A-22](#). If necessary, the origin of the coordinate system may be translated from the center of the display to aid in orientation of the hand phantom and EUT combination provided that the EUT remains inside the quiet zone.

FIGURE A-21 EUT DISPLAY ALIGNMENT FEATURES

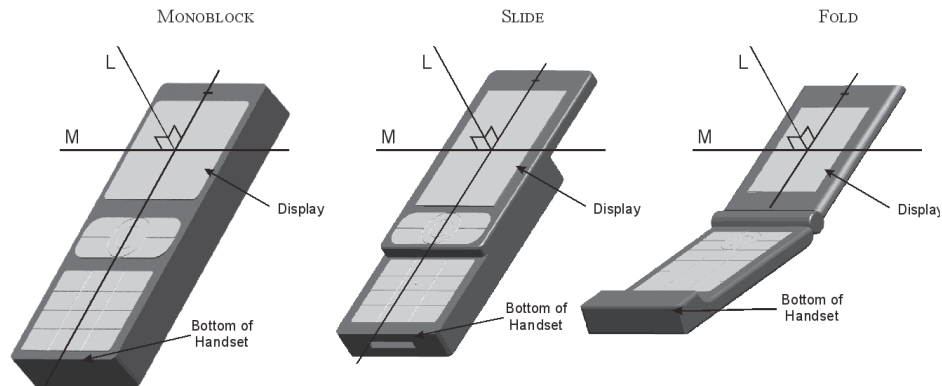
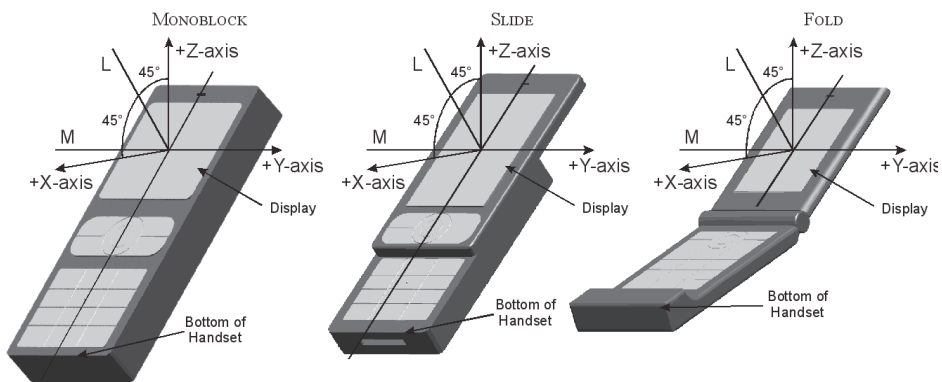

FIGURE A-22 DEFINITION OF COORDINATE SYSTEM FOR EUT WITH HAND PHANTOM IN DATA MODE



A.1.5.1 Mounting a Narrow EUT in the Narrow Hand Phantom for Data Mode

This hand phantom is suitable for use with all EUTs narrower than 56 mm.

User grip studies have shown that the average grip for narrow EUTs has the index finger supporting the back of the device and the thumb positioned over a central navigation wheel or “nav key.” To help achieve a consistent positioning that conforms to the grip studies, Alignment Tool A (Figure A-23) is first used to measure the distance between the bottom of the EUT and the center of its nav key. The EUT is then positioned in accordance with ruled markings on a conformal palm spacer corresponding to the right or left configuration.

1. Place the EUT on the EUT alignment tool A (as shown in Figure A-23).
2. Record the chin length from the scale at the bottom of the alignment tool.
3. Record the location of the navigation key (or the “2” key, if no navigation key is present) on the side ruler of the EUT alignment tool A. The key’s center is used as the reference.

4. Add the two readings from step 2 and 3 together. If the sum is less than 30 mm, then use 30 mm instead.
5. Place the EUT on the narrow data palm spacer and align the side of the EUT with the side wall of the spacer.
6. The bottom edge of the EUT shall be placed on the narrow data palm spacer at the ruling corresponding to the value obtained in step 4 (See [Figure A-24](#)).
7. Ensure that the index finger is in contact with the back of the EUT. If the device is very narrow and/or thin, it may occur that the middle finger does not curl tightly enough to contact the EUT. In such case, in order to ensure consistent test results, no attempt should be made to force the fingertip to contact the EUT. Touch fastener material may be used to maintain the EUT in the desired position.

The material for the narrow data palm spacer shall be hollow with a wall thickness less than 2 mm, and a dielectric constant of less than 5.0 and a loss tangent of less than 0.05 or it shall be solid with a dielectric constant of less than 1.3 and a loss tangent of less than 0.003. It may feature a groove or cavity to accommodate touch fastener material.

FIGURE A-23 MEASURING A NARROW EUT IN ALIGNMENT TOOL A FOR HAND ONLY (“DATA MODE”) TESTING

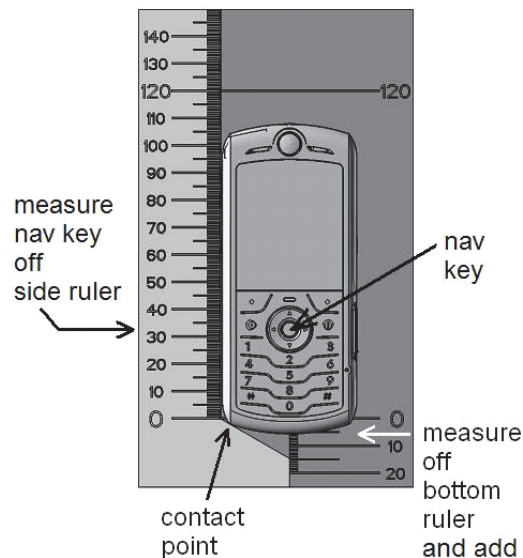
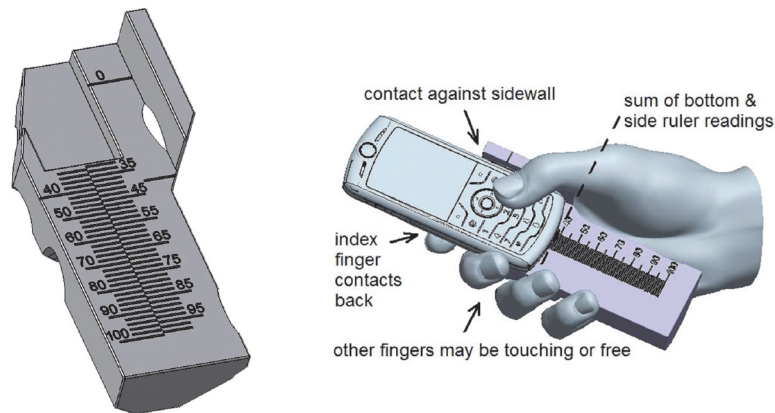

FIGURE A-24 NARROW DATA PALM SPACER



Note: A mirror-image configuration of the palm spacer shall be used for the left-handed narrow data grip.

A.1.5.2 Mounting a Wide EUT in the PDA Phantom for Data Mode

This hand phantom is suitable for use with EUTs of width 56-72 mm. The positioning of the EUT in the PDA hand for data mode is identical to that for talk mode, and is already described in [Appendix A.1.4.3](#).

A.1.5.3 Mounting a Wide EUT in the Wide Grip Phantom for Data Mode

The Wide Grip hand phantom is for an EUT having width greater than 72 mm, and not greater than 92 mm. Positioning of the EUT in the Wide Grip hand phantom for data mode is identical to that for talk mode, as described in [Appendix A.1.4.4](#).

A.2 Test Systems Set-up

Each of the two referenced chamber setups have different coordinate system orientations. This is due to the difference in implementation of the chamber axes. However, the EUT coordinate systems of the previous sections will apply independent of the physical orientations of the EUT inside the chamber. [Figure A-25](#) below shows the typical setup using a combined-axis system. In addition to the pictured theta-axis rotation, the EUT will have to be rotated about the Z-axis (phi rotation) in order to perform the full spherical scans.

FIGURE A-25 TYPICAL SETUP FOR A COMBINED-AXES SYSTEM

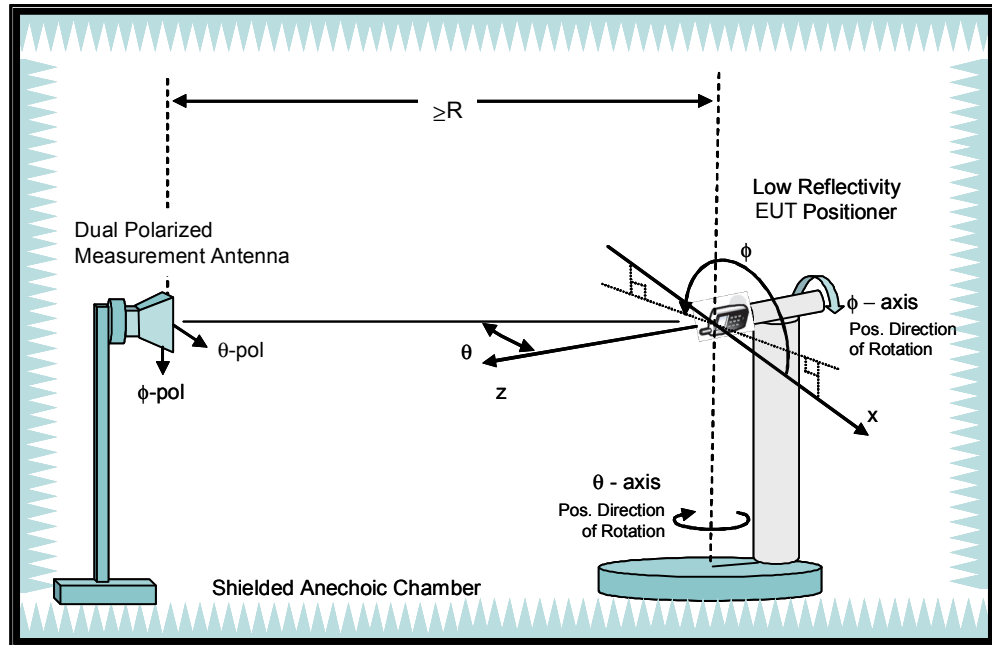
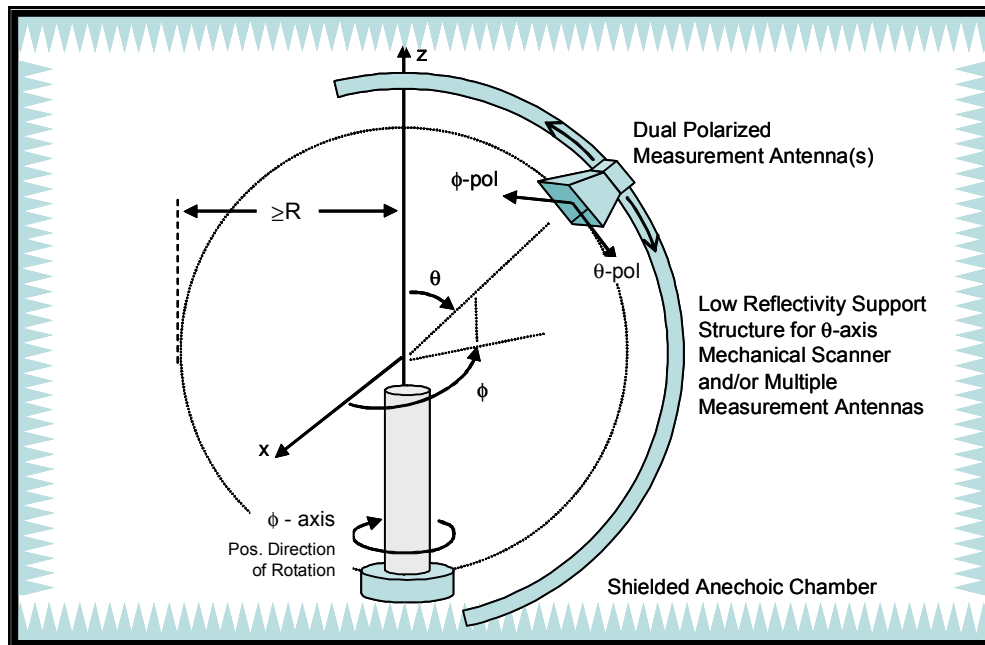

Figure A-26 below shows the typical setup using the distributed-axes system. In this configuration, the phi and theta angles are traversed separately by the distributed positioners in the chamber.

FIGURE A-26 TYPICAL SETUP FOR A DISTRIBUTED-AXES SYSTEM



A.3 Test Setup—Instrumentation

Typical system schematics for both TRP and TIS measurements are shown in [Figure A-27](#) to [Figure A-33](#). The shown configurations are only representative examples of common measurement systems and do not represent an exhaustive list of allowable configurations. For more details regarding selection and configuration of measurement instrumentation, see [Appendix D](#).

[Figure A-27](#) through [Figure A-33](#) also include illustrations showing conducted power and conducted sensitivity measurement setups. It is recommended that the conducted measurements be performed inside a shielded environment. For conducted TIS measurements, a shielded environment is required since interferences can directly influence the measurement results. For conducted transmit power tests, a shielded environment is recommended since interference signals may cause dropped calls during the power measurement. The mobile EUT antenna connector is typically a special miniature RF connector on the EUT and is used as a RF-Test-Jack for conducted measurements. If the EUT does not readily support an antenna port for conducted measurements, a separate modified EUT may be provided for all conducted measurements. The mobile manufacturer must provide an RF test cable that terminates in a common SMA or N type connector to mate with the EUT antenna connector, along with the associated RF insertion loss for that cable connection. The insertion loss of the RF-Test-Cable must be factored into measurements referenced to the antenna connector.

FIGURE A-27 SIMPLIFIED BLOCK DIAGRAM SHOWING A COMMON CONFIGURATION FOR THE USE OF A BASE STATION SIMULATOR FOR TRP MEASUREMENTS

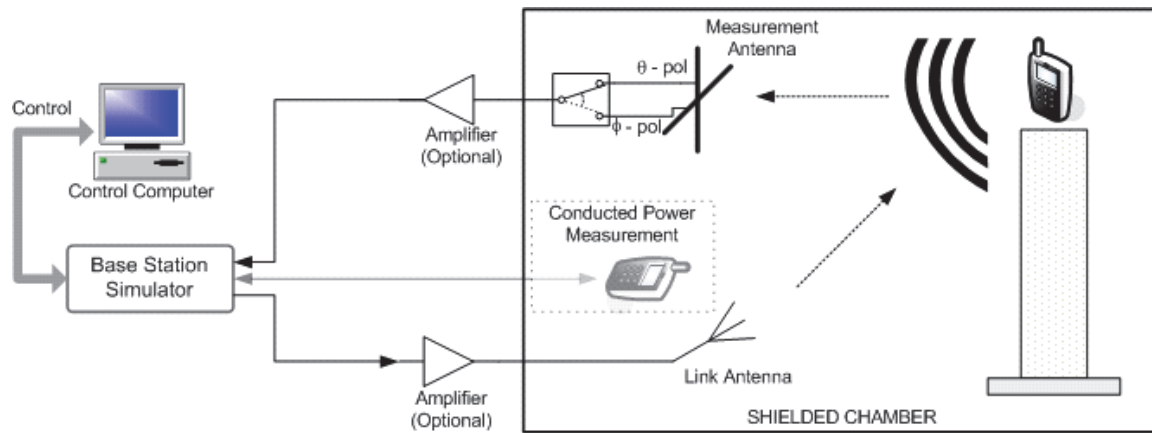

The forward link communication is transmitted through the communication link antenna and the reverse link is received through the measurement antenna. This configuration supports amplification of both signal paths if necessary.

FIGURE A-28 SIMPLIFIED BLOCK DIAGRAM SHOWING A COMMON CONFIGURATION FOR TIS MEASUREMENTS

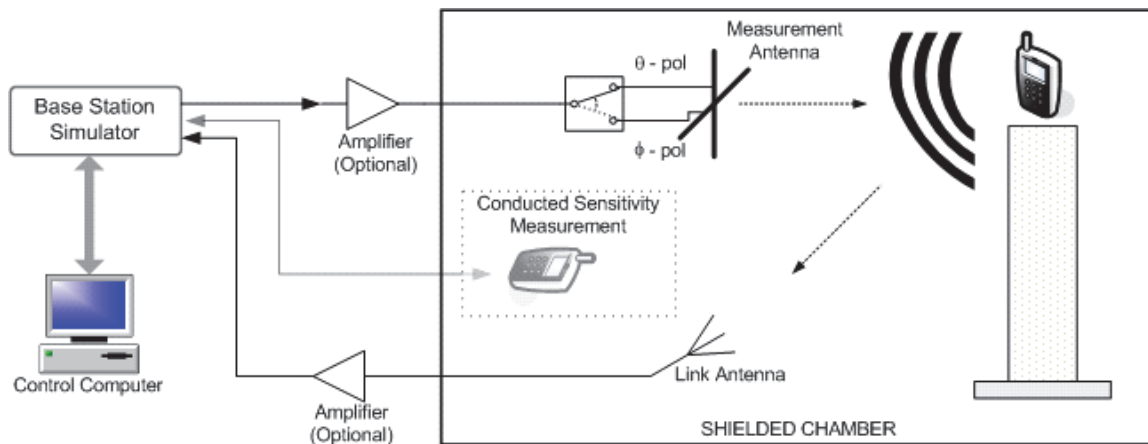

The forward link communication is transmitted through the measurement antenna and the reverse link is received through the communication link antenna. This configuration supports amplification of both signal paths if necessary.

FIGURE A-29 SIMPLIFIED BLOCK DIAGRAM FOR TRP MEASUREMENTS USING A SPECTRUM ANALYZER

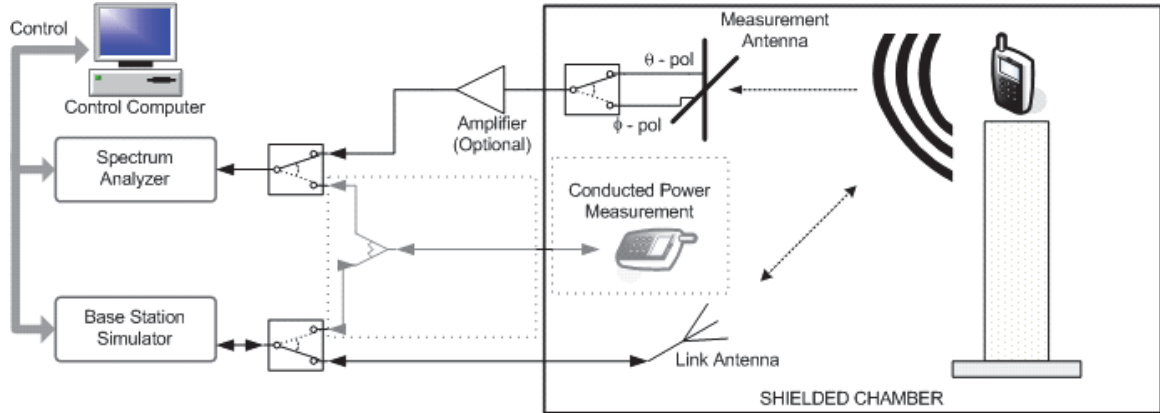

Both forward and reverse link communications between the mobile and base station simulator are carried out through a separate communication link antenna. Instead of a spectrum analyzer, any other dedicated receiver can be used.

FIGURE A-30 SIMPLIFIED BLOCK DIAGRAM FOR TRP MEASUREMENTS USING A SPECTRUM ANALYZER WITH A POWER DIVIDER

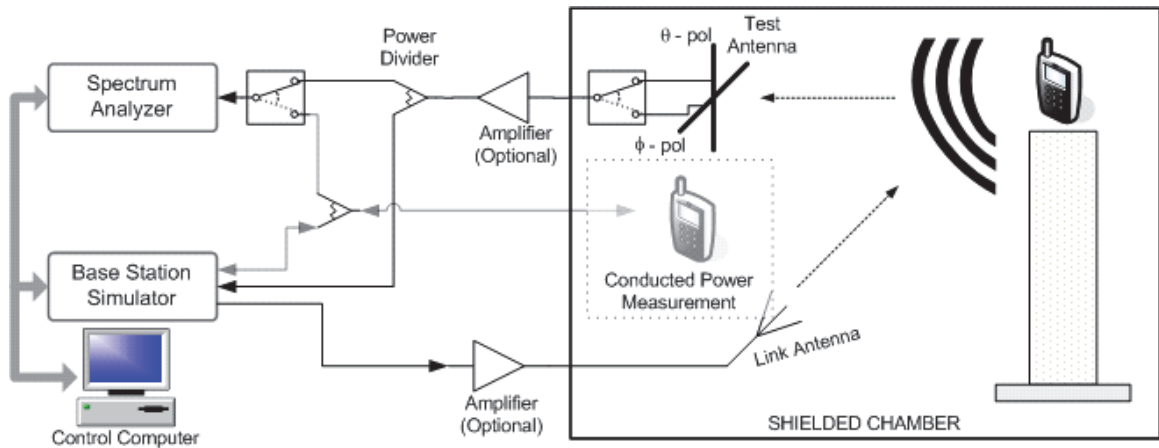

Forward link communication between the mobile and base station simulator is carried out through a separate communication link antenna while the reverse link is carried through the measurement antenna. Instead of a spectrum analyzer, any other dedicated receiver can be used.

FIGURE A-31 SIMPLIFIED BLOCK DIAGRAM ILLUSTRATING A METHOD WITH EXTERNAL AMPLIFIERS

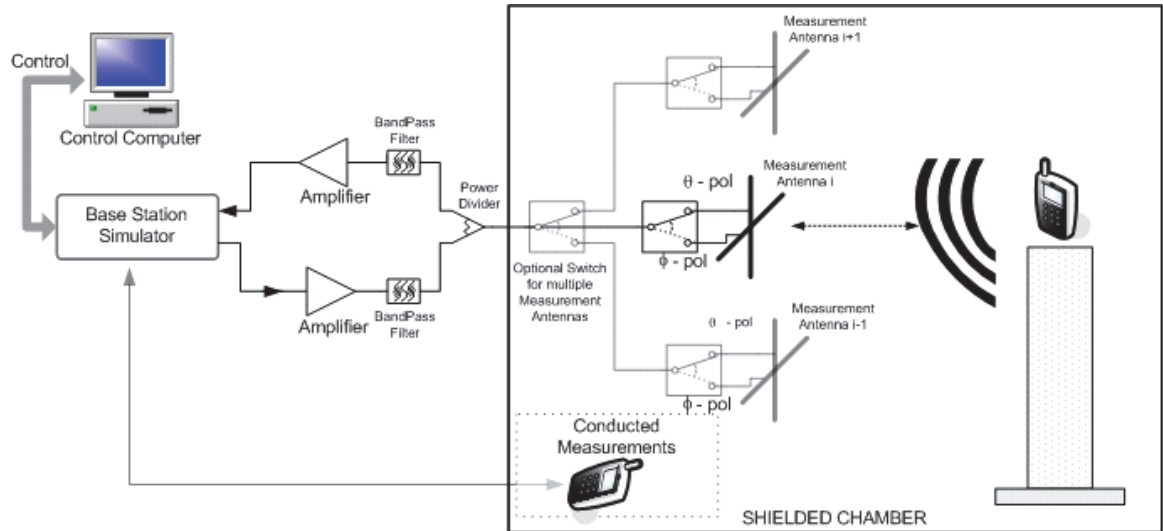

The method of externally amplifying both forward and reverse link communication signals and combining them into one signal routed to/from one (or more) measurement antenna(s) is shown. This configuration supports both TRP and TIS measurements.

FIGURE A-32 SIMPLIFIED BLOCK DIAGRAM FOR TRP MEASUREMENTS USING DUAL SPECTRUM ANALYZERS

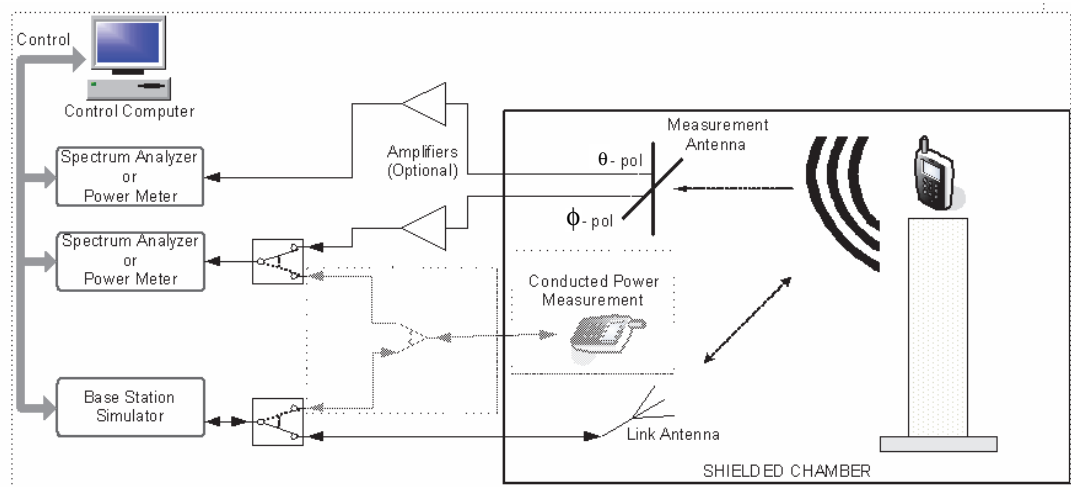

Both forward and reverse link communications between the mobile and base station simulator are carried out through a separate communication link antenna. Instead of a spectrum analyzer, any other dedicated receiver can be used.

FIGURE A-33 SIMPLIFIED BLOCK DIAGRAM FOR TRP MEASUREMENTS USING DUAL SPECTRUM ANALYZERS AND A POWER DIVIDER

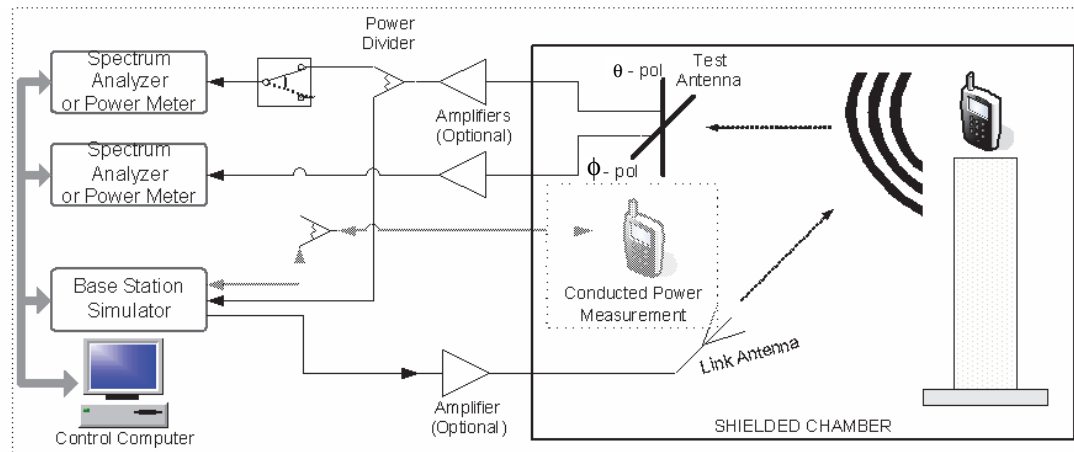

Forward link communication between the mobile and base station simulator is carried out through a separate communication link antenna while the reverse link is carried out through the measurement antenna. Instead of a spectrum analyzer, any other dedicated receiver can be used.

Appendix B Reporting of Test Results (Normative)

B.1 Test Report Tables

Test reports and files shall be provided as described in this section. Deliverables consist of a Range Reference Measurement data file (Section 4) and EUT Measurement data files (as described in this section) for each EUT characterized.

Data from the tests on every product shall be reported in three ways:

1. A complete set of the measurement data for every test supplied electronically in a format that can be easily read (e.g., Excel, etc.).
2. A complete set of test report forms from the spreadsheet "OTA 3.9.x Appendix B Tables." The sheet "Contents" includes more details for which tables need to be provided.
3. A series of 3D plots based on Table B-29 through Table B-33 of the mid-channel cellular patterns, GNSS patterns, and MBS patterns as applicable, as seen from a representative viewing angle

Please note the following abbreviations are used in the tables in the spreadsheet "OTA 3.9.x Appendix B Tables."

FS = Free Space

BH = Beside Head (Head Phantom Only)

BHL = Beside Head Left Side (Head Phantom Only)

BHR = Beside Head Right Side (Head Phantom Only)

HL = Hand Left (Hand Phantom Only)

HR = Hand Right (Hand Phantom Only)

BHHL = Beside Head and Hand Left Side (Head and Hand Phantom)

BHHR = Beside Head and Hand Right Side (Head and Hand Phantom)

WL = Wrist-Worn Left (Forearm Phantom)

WR = Wrist-Worn Right (Forearm Phantom)

The Summation Test Report (Table B-4 through Table B-20) and Summation Test Report Plot Matrix (Table B-29 through Table B-33) shall be included as a separate file and also be included at the beginning of the main test report submitted. Table B-4 through Table B-6 shall not be used for reporting LTE CA test results. The TIS Summation Test Report shall also contain the Intermediate Channel Relative Sensitivity table (Table B-21 through Table B-28.) When multiple test configurations and/or antennas are tested, then these tables shall be completed multiple times with the appropriate test configurations and antennas included in the table header. Tables B-7 through B-10 are no longer required.

The results of the calculations for expanded uncertainty for both TRP and TIS measurements shall be reported. The test performance requirements shall not be adjusted by the measurement uncertainty when determining compliance of the EUTs.

B.2 EUT Measurement Data Files

Spherical-scan pattern data shall be supplied in a format accessible (i.e., readable) for additional examination and computation as outlined in Table B-1015 and Table B-1016 (located in the spreadsheet “OTA 3.9.x Appendix B Tables.”) The pattern data reported are Effective Isotropic Radiated Power (EIRP) for transmit tests and Effective Isotropic Sensitivity (EIS) for receive tests, as defined in [Appendix E](#). Both EIRP and EIS quantities shall be reported in units of dBm. In case of RSS-based measurements, the pattern data shall also be reported as the raw RSS values. For example report C/N_0 values for A-GPS, see [Section 6.13](#). Relative phase quantities shall be reported in radians. For each cellular radio mode and frequency band combination that the EUT supports, complete spherical pattern files shall be provided for the following transmit and receive tests, as specified in [Section 5](#) and [Section 6](#): (3 different channels³) (N different EUT configurations⁴, if applicable) (up to 5 different test conditions⁵).

Each transmit-test spherical-scan file shall contain measurements for 11 theta cuts, 24 phi cuts, and 2 polarizations. Based on samples measured every 15 degrees of rotation for each cut, 528 measurements are thus recorded in each transmit test file. Each receive-test spherical-scan file shall contain measurements for 5 theta cuts, 12 phi cuts, and 2 polarizations. Based on samples measured every 30 degrees of rotation for each cut, 120 measurements are recorded in each receive test file.

In cases where the Spiral Scan TRP method has been used, the raw data shall contain measurements for a minimum of 350 points of 2 polarizations (700 total measurement points). There shall be a maximum spacing between subsequent spirals of 15 degrees in theta in each polarization. Ideally, points shall be measured between theta=0 degrees and theta=180 degrees. In cases where the measurement system does not allow measurements at the poles, measurements shall be performed between at least theta=15 degrees and theta=165 degrees and additional measurement points shall be collected at the minimum and/or maximum theta values at no less than 6 phi values. The measurements near the extreme theta values are then used to interpolate the point values between the extreme values of the measurement system and the pole(s), e.g., 165-180 degrees. In the reported pattern data, all points shall be labeled as to whether they are a measured or interpolated. Alternatively, it shall be stated in the report which measurement range for theta the test system supports.

In cases where Theta Dependent Phi Optimization has been used for TRP measurements, each transmit-test spherical-scan file shall contain measurements for 11 theta, variable phi cuts and 2 polarizations. In addition, the theta and phi angles shall be recorded for every measurement. In cases where Theta Dependent Phi Optimization has been used for TIS measurements, each receive-test spherical-scan file shall contain measurements for 5 theta, variable phi cuts, and 2 polarizations. In addition, the theta and phi angles shall be recorded for every measurement.

-
3. “Channel” refers to the appropriate frequency pair for transmit and receive.
 4. “EUT configuration” refers to antenna stowed or deployed, slide opened or closed, etc. for those EUTs that support multiple configurations.
 5. “Test conditions” are free-space, right hand only, right hand and head, etc. as specified in [Appendix A](#) and [Appendix C](#).

In addition to the spherical pattern data, for each cellular radio mode and band that the EUT supports, a file showing the appropriate BER, BLER, FER, or PER outcome per channel for the additional intermediate-channel, single-point receive tests specified in [Section 6](#) is also required. The contents and number of channels reported in the intermediate-channel receive-test file will vary depending on the cellular radio mode, as described in [Section 6](#).

For RSS-based measurements, in addition, the data for the linearization ([Section 6.15.4.2](#)) and for the sensitivity search shall be supplied.

B.3 Calculating Spatially Averaged Quantities

This subsection defines the figures of merit that shall be used to calculate the spatially averaged EIRP and EIS. The objective is to use the following figures of merit to observe trends in performance over different products.

The spatially averaged effective radiated power and sensitivity values shall be derived from the measurement data. The spatial average is calculated as a Sin-Theta weighted ($\sin(\theta)$) average over all elevation angles. Uniform weighting is also used to average over all azimuths. “Sin-Theta weighted average” is an averaging scheme that puts more emphasis on horizon data than zenith and nadir and is appropriate for use when samples are taken uniformly in theta and phi.

N and M are the number of angular intervals in theta and phi, respectively. Note that N and M are different for the transmit and receive measurements. For transmit tests, $N = 12$ and $M = 24$. For receive tests, $N = 6$ and $M = 12$. In both cases, the respective theta and phi indices, i and j , correspond to the measurement angles as demonstrated in Table B-1015 and Table B-1016 located in the spreadsheet “OTA 3.9.x Appendix B Tables.” A complete definition of terms is given in [Appendix E](#).

When the measurement has been made based on RSS values, the spatially averaged quantities have to be calculated according to the guidelines given in [Appendix E.1.1](#) using the linearized RSS values and the sensitivity search result.

Although the pattern data (EIRP and EIS quantities) are reported in units of dBm, the data is to be converted to linear units of milliwatts (mW) to perform the calculations in this subsection.

B.3.1 Total Radiated Power

For a complete sphere measured with N theta intervals and M phi intervals, both with even angular spacing, the Total Radiated Power is calculated as follows.

Total Radiated Power:

EQUATION B.1

$$TRP \cong \frac{\pi}{2NM} \sum_{i=1}^{N-1} \sum_{j=0}^{M-1} [EiRP_{\theta}(\theta_i, \phi_j) + EiRP_{\phi}(\theta_i, \phi_j)] \sin(\theta_i)$$

B.3.1.1 Theta Dependent Phi TRP

For the Theta Dependent Phi Optimization, where the number of phi intervals, M_i , is a function of the theta angle, the Total Radiated Power is calculated as follows:

EQUATION B.2

$$TRP \cong \frac{\pi}{2N} \sum_{i=1}^{N-1} \frac{1}{M_i} \sum_{j=0}^{M_i-1} [EiRP_{\theta}(\theta_i, \phi_j) + EiRP_{\phi}(\theta_i, \phi_j)] \sin(\theta_i)$$

where:

$$M_i = N_{\phi}(\theta_i)$$

B.3.1.2 Spiral Scan TRP

When using the standard measurement grid, the sphere has N theta intervals and M phi intervals, both with even angular spacing. N and M are integers and the Total Radiated Power is calculated per [Equation B.1](#).

In the case of the spiral scan measurement grid, N and M need not be integers and can vary between measurements, but are nonetheless important in deriving the formulas for calculating TRP and other PRP figures.

The relationship between M , N , and the average step sizes in Theta and Phi are as follows:

EQUATION B.3

$$M = \frac{2\pi}{\Delta\phi_{ave}}$$

EQUATION B.4

$$N = \frac{\pi}{\Delta\theta_{ave} \cdot M}$$

Where $\Delta\phi_{ave}$ is the average step size in Phi, and $\Delta\theta_{ave}$ is the average step size in Theta.

T or the total number of test points is approximately as follows:

EQUATION B.5

$$T \approx M \cdot N = \frac{\pi}{\Delta\theta_{ave}}$$

The number T represents all test points including virtual test points (i.e., test points between Theta=165 and 180 degrees and/or Theta=0 and 15 degrees which must be extrapolated in some measurement systems).

In the case of the spiral measurement grid, points near a boundary interface must be used in calculating the power of areas proximate to the boundary. This typically involves all points within one rotation in phi from the interface boundary. It is therefore useful to define M_{int} , an integer approximation of M as follows:

EQUATION B.6

$$M_{int} = int \left[\frac{2\pi}{\Delta\phi_{ave}} \right]$$

The equivalent equation to Equation B.1 when using a spiral grid of points to cover the sphere is given by Equation B.7.

For the spiral scan TRP test method, the Total Radiated Power is calculated as follows:

EQUATION B.7

$$TRP \approx \frac{\Delta\theta_{ave} \cdot [P_A + P_B + P_C]}{4 \cdot \Delta\phi_{ave}}$$

Where:

P_A is the power contribution of area A (transition region 1).

P_B is the power contribution of area B (area without special weighting).

P_C is the power contribution of area C (transition region 2).

The exact formulas for P_A , P_B , and P_C depend on the types of regions to be calculated.

When calculating TRP, the following values are used for P_A , P_B , and P_C .

EQUATION B.8

$$P_A = \sum_{t=1}^{A-1} [E_i RP_{\theta}(\theta_t, \phi_t) + E_i RP_{\phi}(\theta_t, \phi_t)] \sin(\theta_t) \cdot [\phi_{t+1} - \phi_{t-1}] \cdot \left[\frac{1}{2} \right]$$

EQUATION B.9

$$P_B = \sum_{t=A}^B [E_i RP_{\theta}(\theta_t, \phi_t) + E_i RP_{\phi}(\theta_t, \phi_t)] \sin(\theta_t) \cdot [\phi_{t+1} - \phi_{t-1}]$$

EQUATION B.10

$$P_C = \sum_{t=B+1}^T [E_i RP_\theta(\theta_t, \phi_t) + E_i RP_\phi(\theta_t, \phi_t)] \sin(\theta_t) \cdot [\phi_{t+1} - \phi_{t-1}] \cdot \left[\frac{1}{2} \right]$$

Where ϕ_t and θ_t are the phi and theta angle associated with test point t in the spiral scan test. M_{int} is defined in Equation B.6.

A is defined as the test point which is one revolution in phi from the pole where one started measuring (theta =0 degrees). B is the point at which the test point is an entire revolution from the final point at the end of the measurement (theta =180 degrees). In some cases A and/or B may be an extrapolated point as some measurement systems cannot measure to the point $\theta =180^\circ$. Note that $A \cong M_{int}$ and $T \cong M_{int}$ where T is the total number of measurement points.

This method assumes that $EIRP_\phi$ and $EIRP_\theta$ measurements are taken at the same location. If $EIRP_\phi$ and $EIRP_\theta$ are measured alternating using a single spiral cut or two spiral measurements are taken to measure $EIRP_\phi$ and $EIRP_\theta$ separately, then the sums in Equation B.8 to Equation B.10 should split for $EIRP_\phi$ and $EIRP_\theta$ as different angles are used for the different polarizations.

B.3.2 Near-Horizon Partial Radiated Power

For a complete sphere measured with $N = 12$ theta intervals and M phi intervals, both with even angular spacing, the Near-Horizon Partial Radiated Power is calculated as follows.

Power radiated over ± 45 degrees near the Horizon:

EQUATION B.11

$$NHPRP_{\pm 45} \cong \frac{\pi}{2NM} \left(\frac{cut_3 + cut_9}{2} + \sum_{i=4}^8 cut_i \right)$$

where

$$cut_i = \sum_{j=0}^{M-1} [E_i RP_\theta(\theta_i, \phi_j) + E_i RP_\phi(\theta_i, \phi_j)] \sin(\theta_i)$$

represents the weighted sum of each conical cut.

Power Radiated over ± 30 degrees near the Horizon:

EQUATION B.12

$$NHPRP_{\pm 30} \cong \frac{\pi}{2NM} \left(\frac{cut_4 + cut_8}{2} + \sum_{i=5}^7 cut_i \right)$$

where, again,

$$cut_i = \sum_{j=0}^{M_i-1} [EiRP_{\theta}(\theta_i, \phi_j) + EiRP_{\phi}(\theta_i, \phi_j)] \sin(\theta_i)$$

represents the weighted sum of each conical cut.

B.3.2.1 Theta Dependent Phi NHPRP

For the Theta Dependent Phi Optimization, where the number of phi intervals, M_i , is a function of the theta angle, these equations become:

Power radiated over ± 45 degrees near the Horizon:

EQUATION B.13

$$NHPRP_{\pm 45} \cong \frac{\pi}{2N} \left(\frac{cut_3 + cut_9}{2} + \sum_{i=4}^8 cut_i \right)$$

where:

$$cut_i = \frac{1}{M_i} \sum_{j=0}^{M_i-1} [EiRP_{\theta}(\theta_i, \phi_j) + EiRP_{\phi}(\theta_i, \phi_j)] \sin(\theta_i)$$

represents the weighted sum of each conical cut.

Power Radiated over ± 30 degrees near the Horizon:

EQUATION B.14

$$NHPRP_{\pm 30} \cong \frac{\pi}{2N} \left(\frac{cut_4 + cut_8}{2} + \sum_{i=5}^7 cut_i \right)$$

where, again,

$$cut_i = \frac{1}{M_i} \sum_{j=0}^{M_i-1} [EiRP_{\theta}(\theta_i, \phi_j) + EiRP_{\phi}(\theta_i, \phi_j)] \sin(\theta_i)$$

represents the weighted sum of each conical cut.

B.3.2.2 Spiral Scan NHPRP

To calculate NHPRP using the spiral method, an equation similar to [Equation B.15](#) is used with slight modification to the terms P_A , P_B , and P_C .

EQUATION B.15

$$NHPRP \approx \frac{\Delta\theta_{ave} \cdot [P_A + P_B + P_C]}{4 \cdot \Delta\phi_{ave}}$$

Points *A* and *B* are redefined as follows:

- *A* is the upper boundary point for the measurement region being calculated (for example, the point closest to theta= 45 degrees for NHPRP 45)
- *B* is the lower boundary point for the region being calculated.

Where

P_A represents the transition area at the upper boundary of the NHPRP region,

P_B represents the area within the NHPRP region which is non-transitional and

P_C represents the transition area at the lower boundary of the NHPRP region.

$\Delta\phi_{ave}$ is the average step size in Phi, and $\Delta\theta_{ave}$ is the average step size in Theta.

The equations for the contributions for NHPRP are as follows:

EQUATION B.16

$$P_A = \sum_{t=A-M_{int}}^{A+M_{int}} [EiRP_{\theta}(\theta_t, \phi_t) + EiRP_{\phi}(\theta_t, \phi_t)] \sin(\theta_t) \cdot [\phi_{t+1} - \phi_{t-1}] \cdot \left[1 - \frac{(\theta_{A+M_{int}} - \theta_t)}{(\theta_{A+M_{int}} - \theta_{A-M_{int}})} \right]$$

EQUATION B.17

$$P_B = \sum_{t=A+M_{int}+1}^{B-M_{int}-1} [EiRP_{\theta}(\theta_t, \phi_t) + EiRP_{\phi}(\theta_t, \phi_t)] \sin(\theta_t) \cdot [\phi_{t+1} - \phi_{t-1}]$$

EQUATION B.18

$$P_C = \sum_{t=B-M_{int}}^{B+M_{int}} [EiRP_{\theta}(\theta_t, \phi_t) + EiRP_{\phi}(\theta_t, \phi_t)] \sin(\theta_t) \cdot [\phi_{t+1} - \phi_{t-1}] \cdot \left[1 - \frac{(\theta_t - \theta_{B-M_{int}})}{(\theta_{B+M_{int}} - \theta_{B-M_{int}})} \right]$$

Where ϕ_t and θ_t are the phi and theta angle associated with test point *t* in the spiral scan test. M_{int} is defined in [Equation B.6](#).

This method assumes that $EiRP_{\phi}$ and $EiRP_{\theta}$ are taken at the same location. If $EiRP_{\phi}$ and $EiRP_{\theta}$ are measured alternating using a single spiral cut or two spiral measurements are taken to measure $EiRP_{\phi}$ and $EiRP_{\theta}$ separately, then the sums in [Equation B.16](#) to [Equation B.18](#) should split for $EiRP_{\phi}$ and $EiRP_{\theta}$ as different angles are used for the different polarizations.

B.3.3 Total Isotropic Sensitivity

For a complete sphere measured with N theta intervals and M phi intervals, both with even angular spacing, the Total Isotropic Sensitivity is calculated as follows.

Total Isotropic Sensitivity:

EQUATION B.19

$$TIS \cong \frac{2NM}{\pi \sum_{i=1}^{N-1} \sum_{j=0}^{M-1} \left[\frac{1}{EIS_{\theta}(\theta_i, \phi_j)} + \frac{1}{EIS_{\phi}(\theta_i, \phi_j)} \right]} \sin(\theta_i)$$

where EIS is the radiated effective isotropic sensitivity measured at each direction and polarization.

B.3.3.1 Theta Dependent Phi TIS

For the Theta Dependent Phi Optimization, where the number of phi intervals, M_i , is a function of the theta angle, the Total Isotropic Sensitivity is calculated as follows:

EQUATION B.20

$$TIS \cong \frac{1}{\frac{\pi}{2N} \sum_{i=1}^{N-1} \frac{1}{M_i} \sum_{j=0}^{M_i-1} \left[\frac{1}{EIS_{\theta}(\theta_i, \phi_j)} + \frac{1}{EIS_{\phi}(\theta_i, \phi_j)} \right]} \sin(\theta_i)$$

B.3.4 Near-Horizon Partial Isotropic Sensitivity

For a complete sphere measured with $N = 6$ theta intervals and M phi intervals, both with even angular spacing, the Near-Horizon Partial Isotropic Sensitivity is calculated as follows.

For sensitivity considered over ± 45 degrees near the Horizon:

EQUATION B.21

$$NHPIS_{\pm 45} \cong \frac{2NM}{\pi \left(\frac{\sqrt{2}}{16} (cut_1 + cut_5) + \frac{\sqrt{2} + 6\sqrt{3}}{16} (cut_2 + cut_4) + cut_3 \right)}$$

where

$$cut_i = \sum_{j=0}^{M-1} \left[\frac{1}{EIS_{\theta}(\theta_i, \phi_j)} + \frac{1}{EIS_{\phi}(\theta_i, \phi_j)} \right]$$

represents the sum of each conical cut **without any weighting** (the $\sin(\theta_i)$ terms have already been calculated into the previous equation).

For sensitivity considered over ± 30 degrees near the Horizon:

EQUATION B.22

$$NHPIS_{\pm 30} \cong \frac{2NM}{\pi \left(\frac{cut_2 + cut_4}{2} + cut_3 \right)}$$

where

$$cut_i = \sum_{j=0}^{M-1} \left[\frac{1}{EIS_{\theta}(\theta_i, \phi_j)} + \frac{1}{EIS_{\phi}(\theta_i, \phi_j)} \right] \sin(\theta_i)$$

represents the weighted sum of each conical cut.

B.3.4.1 Theta Dependent Phi NHPIS

For the Theta Dependent Phi Optimization, where the number of phi intervals, M_i , is a function of the theta angle, these equations become:

For sensitivity considered over ± 45 degrees near the Horizon:

EQUATION B.23

$$NHPIS_{\pm 45} \cong \frac{2N}{\pi \left(\frac{\sqrt{2}}{16} (cut_1 + cut_5) + \frac{\sqrt{2} + 6\sqrt{3}}{16} (cut_2 + cut_4) + cut_3 \right)}$$

where:

$$cut_i = \frac{1}{M_i} \sum_{j=0}^{M_i-1} \left[\frac{1}{EIS_{\theta}(\theta_i, \phi_j)} + \frac{1}{EIS_{\phi}(\theta_i, \phi_j)} \right]$$

represents the weighted sum of each conical cut.

For sensitivity considered over ± 30 degrees near the Horizon:

EQUATION B.24

$$NHPIS_{\pm 30} \cong \frac{2N}{\pi \left(\frac{cut_2 + cut_4}{2} + cut_3 \right)}$$

where:

$$cut_i = \frac{1}{M_i} \sum_{j=0}^{M_i-1} \left[\frac{1}{EIS_{\theta}(\theta_i, \phi_j)} + \frac{1}{EIS_{\phi}(\theta_i, \phi_j)} \right] \sin(\theta_i)$$

represents the weighted sum of each conical cut.

B.3.5 Upper Hemisphere Isotropic Sensitivity (UHS)

For a complete sphere measured with N theta intervals and M phi intervals, both with even angular spacing, the Upper Hemisphere Isotropic Sensitivity, which represents the total power radiated in the theta range from 0 to 90 degrees is calculated as follows.

EQUATION B.25

$$UHS \cong \frac{2NM}{\pi \left(\sum_{i=1}^{\frac{N-1}{2}} cut_i + \frac{1}{2} cut_{\frac{N}{2}} \right)}$$

where:

$$cut_i = \sum_{j=0}^{M-1} \left[\frac{1}{EIS_{\theta}(\theta_i, \phi_j)} + \frac{1}{EIS_{\phi}(\theta_i, \phi_j)} \right] \sin(\theta_i)$$

represents the weighted sum of each conical cut.

B.3.5.1 Theta Dependent Phi UHS

For the Theta Dependent Phi Optimization, where the number of phi intervals, M_i , is a function of the theta angle, the calculation of UHS is defined as follows:

EQUATION B.26

$$UHS \cong \frac{2N}{\pi \left(\sum_{i=1}^{\frac{N-1}{2}} cut_i + \frac{1}{2} cut_{\frac{N}{2}} \right)}$$

where:

$$cut_i = \frac{1}{M_i} \sum_{j=0}^{M_i-1} \left[\frac{1}{EIS_{\theta}(\theta_i, \phi_j)} + \frac{1}{EIS_{\phi}(\theta_i, \phi_j)} \right] \sin(\theta_i)$$

represents the weighted sum of each conical cut.

B.3.6 Partial Isotropic GNSS Sensitivity (PIGS)

For a complete sphere measured with $N=6$ theta intervals (30 degree spacing) and M phi intervals, both with even angular spacing, the Partial Isotropic GNSS Sensitivity, which represents the total power radiated in the theta range from 0 to 120 degrees is calculated as follows:

EQUATION B.27

$$PIGS \cong \frac{2NM}{\pi \left(\sum_{i=1}^{\frac{N}{2}} cut_i + \frac{1}{2} cut_{\frac{N}{2}+1} \right)}$$

where:

$$cut_i = \sum_{j=0}^{M-1} \left[\frac{1}{EIS_{\theta}(\theta_i, \phi_j)} + \frac{1}{EIS_{\phi}(\theta_i, \phi_j)} \right] \sin(\theta_i)$$

represents the weighted sum of each conical cut.

B.3.6.1 Theta Dependent Phi PIGS

For the Theta Dependent Phi Optimization, where the number of phi intervals, M_i , is a function of the theta angle, the calculation of PIGS is defined as follows:

EQUATION B.28

$$PIGS \cong \frac{2N}{\pi \left(\sum_{i=1}^{\frac{N}{2}} cut_i + \frac{1}{2} cut_{\frac{N}{2}+1} \right)}$$

where:

$$cut_i = \frac{1}{M_i} \sum_{j=0}^{M_i-1} \left[\frac{1}{EIS_{\theta}(\theta_i, \phi_j)} + \frac{1}{EIS_{\phi}(\theta_i, \phi_j)} \right] \sin(\theta_i)$$

represents the weighted sum of each conical cut.

B.3.7 Calculations When Using the Spiral Scan TRP Measurement Method

When using the spiral scan TRP test method, the measurement grid differs from the standard, regularly spaced test points. As such, the method for calculating radiated power figures also varies. The results

achieved however are identical apart from any random uncertainty which may be present in the measurement.

The following sections and formulas illustrate the method for calculating TRP when the EIRP measurements of phi and theta are taken at the same location. If a stepped acquisition method is used or two spiral measurements are taken (one for EIRP of phi and the second for EIRP of theta), then the calculation formulas must be adjusted accordingly.

B.3.7.1 Total Radiated Power

When using the standard measurement grid, the sphere has N theta intervals and M phi intervals, both with even angular spacing. N and M are integers and the Total Radiated Power is calculated per Equation B.29.

In the case of the spiral scan measurement grid, N and M need not be integers and can vary between measurements, but are nonetheless important in deriving the formulas for calculating TRP and other PRP figures.

The relationship between M, N, and the average step sizes in Theta and Phi are as follows:

EQUATION B.29

$$M = \frac{2\pi}{\Delta\phi_{ave}}$$

EQUATION B.30

$$N = \frac{\pi}{\Delta\theta_{ave} \cdot M}$$

T or the total number of test points is approximately as follows:

EQUATION B.31

$$T \approx M \cdot N = \frac{\pi}{\Delta\theta_{ave}}$$

The number T represents all test points including virtual test points (i.e., test points between Theta=165 and 180 degrees and/or Theta=0 and 15 degrees which must be extrapolated in some measurement systems).

In the case of the spiral measurement grid, points near a boundary interface must be used in calculating the power of areas proximate to the boundary. This typically involves all points within +/- one rotation in phi from the interface boundary. It is therefore useful to define M_{int} , an integer approximation of M as follows:

EQUATION B.32

$$M_{int} = int \left[\frac{2\pi}{\Delta\phi_{ave}} \right]$$

The equivalent equation to Equation B.29 when using a spiral grid of points to cover the sphere is given by Equation B.33.

The radiated power in general for a section of sphere with 3 regions of different point weighting is:

EQUATION B.33

$$PRP \approx \frac{\Delta\theta_{ave} \cdot [P_A + P_B + P_C]}{4 \cdot \Delta\phi_{ave}}$$

Where:

P_A is the power contribution of area A (transition region 1).

P_B is the power contribution of area B (area without special weighting).

P_C is the power contribution of area C (transition region 2).

The exact formulas for P_A , P_B , and P_C depend on the types of regions to be calculated.

When calculating TRP, the following values are used for P_A , P_B , and P_C .

EQUATION B.34

$$P_A = \sum_{t=1}^{A-1} [EiRP_{\theta}(\theta_t, \phi_t) + EiRP_{\phi}(\theta_t, \phi_t)] \sin(\theta_t) \cdot [\phi_{t+1} - \phi_{t-1}] \cdot \left[\frac{1}{2} \right]$$

EQUATION B.35

$$P_B = \sum_{t=A}^B [EiRP_{\theta}(\theta_t, \phi_t) + EiRP_{\phi}(\theta_t, \phi_t)] \sin(\theta_t) \cdot [\phi_{t+1} - \phi_{t-1}]$$

EQUATION B.36

$$P_C = \sum_{t=B+1}^T [EiRP_{\theta}(\theta_t, \phi_t) + EiRP_{\phi}(\theta_t, \phi_t)] \sin(\theta_t) \cdot [\phi_{t+1} - \phi_{t-1}] \cdot \left[\frac{1}{2} \right]$$

A is defined as the test point which is one revolution in phi from the pole where one started measuring (theta=0°). B is the point at which the test point is an entire revolution from the final point at the end of the measurement (theta=180°). In some cases A and/or B may be an extrapolated point as some

measurement systems cannot measure to the point theta = 180 degrees. Note that A=M_{int} and T-B=M_{int} where T is the total number of measurement points.

B.3.7.2 Near-Horizon Partial Radiated Power

To calculate NHPRP using the spiral method, the same formula (5) is used as for TRP with slight modification to the terms P_A, P_B, and P_C.

Points A and B are redefined as follows:

- A is the upper boundary point for the measurement region being calculated (for example, the point closest to theta= 45 degrees for NHPRP 45)
- B is the lower boundary point for the region being calculated.

The equations for the contributions for NHPRP are as follows:

EQUATION B.37

$$P_A = \sum_{t=A-M_{int}}^{A+M_{int}} [EiRP_{\theta}(\theta_t, \phi_t) + EiRP_{\phi}(\theta_t, \phi_t)] \sin(\theta_t) \cdot [\phi_{t+1} - \phi_{t-1}] \cdot \left[1 - \frac{(\theta_{A+M_{int}} - \theta_t)}{(\theta_{A+M_{int}} - \theta_{A-M_{int}})} \right]$$

EQUATION B.38

$$P_B = \sum_{t=A+M_{int}+1}^{B-M_{int}-1} [EiRP_{\theta}(\theta_t, \phi_t) + EiRP_{\phi}(\theta_t, \phi_t)] \sin(\theta_t) \cdot [\phi_{t+1} - \phi_{t-1}]$$

EQUATION B.39

$$P_C = \sum_{t=B-M_{int}}^{B+M_{int}} [EiRP_{\theta}(\theta_t, \phi_t) + EiRP_{\phi}(\theta_t, \phi_t)] \sin(\theta_t) \cdot [\phi_{t+1} - \phi_{t-1}] \cdot \left[1 - \frac{(\theta_t - \theta_{B-M_{int}})}{(\theta_{B+M_{int}} - \theta_{B-M_{int}})} \right]$$

Where:

P_A represents the transition area at the upper boundary of the NHPRP region,

P_B represents the area within the NHPRP region which is non-transitional and

P_C represents the transition area at the lower boundary of the NHPRP region.

P_A, P_B, and P_C are substituted into [Equation B.33](#) in order to calculate the relevant NHPRP.

B.4 3-D Plots

Plots shall be submitted for each EUT reported. Plot EIRP in units of dBm. Plot the inverted EIS in units of dBm (-EIS).

B.5 Range Reference Measurement Data File

Files containing the path loss terms employed for the measurements shall be provided as part of the ATL authorization process. [Table 4-2](#) and [Table 4-3](#) illustrate the data file format for these files.

B.6 Photographs and Identification of Hand Phantoms

Photographs of the configurations in which the EUT has been tested with hand phantoms, shall be included in the test report. Photographs of the configurations in which the EUT has been tested with the hand phantom mounted to the head phantom, shall be included in the test report.

In addition, the model and serial numbers of each hand phantom with which the EUT has been tested, shall also be included in the test report.

B.7 Photographs and Identification of Forearm Phantoms

Photographs of the configurations in which the EUT has been tested with forearm phantoms, shall be included in the test report. In addition, the model and serial numbers of each forearm phantom with which the EUT has been tested, shall also be included in the test report.

Appendix C SAM Head and Hand Phantom Definitions and EUT Test Positions (Normative)

This appendix provides references and specifications defining the required phantoms for simulating the human head and hand in various use modes. The specifications include required dimensions and dielectric properties for each phantom. The head phantom is defined based on the SAM Head Phantom defined in IEEE Std 1528-2003™, while the hand phantoms are defined based on an amalgamation of hand dimension data from several references and a number of human factors studies used to determine typical grips for different phone styles.

C.1 SAM Head Phantom—Reference Information

The EUT is to be placed in a head adjacent talk position or in a tilted talk position against the SAM head phantom. The head adjacent talk position in this Test Plan is the same as the “cheek” or “touch” position as is described in IEEE Std 1528-2003. The required head phantom is based on the “SAM” head phantom in the same IEEE standard.

The IEEE Standards Coordinating Committee 34 has defined a specific anthropomorphic mannequin, or 'SAM', as the head model for use in specific absorption rate (SAR) testing. The shape of this head is based on the anthropomorphic data of the 90th percentile adult male head dimensions as published by the US Army [Gorden et al., 1989], except for the distance between the back of the ear and the head.

To provide consistency between these two types of radiated measurements (SAR and TRP/TIS), a nearly identical head phantom definition will apply to all measurements made in accordance with this Test Plan.

Figure C-1 shows the IEEE SCC34 “SAM” anthropomorphic head model where the sections in blue indicate normative areas and the silver band indicates informative data only.

Full details of the head's construction and reference points are given in IEEE Std 1528-2003.

The shell of the head phantom should be made of low permittivity (less than 5.0), low loss material (loss tangent less than 0.05) and have a thickness of 2.0 ± 0.2 mm in all areas where the handset touches (except the ear).

FIGURE C-1 FRONT, BACK AND SIDE VIEW OF THE SAM HEAD PHANTOM



RE and LE shown in [Figure C-1](#) are the Ear Reference Points for the right and left ears respectively.

C.2 Head Phantom Definitions and Requirements

C.2.1 Head Phantom Definition

For use in this Test Plan, this IEEE SAM head model has been extended below the neck region according to the informative data given in CENELEC EN50361: 2001 so that its overall external height (from the top of the skull to bottom of the base with the head looking out horizontally) shall be 300 mm \pm 2 mm. The external width of the base shall be symmetrically truncated to be 225 mm \pm 2 mm. The head phantom appears as shown in [Figure C-2](#), in which the yellow areas indicate the informative CENELEC data.

FIGURE C-2 CTIA SAM HEAD PHANTOM

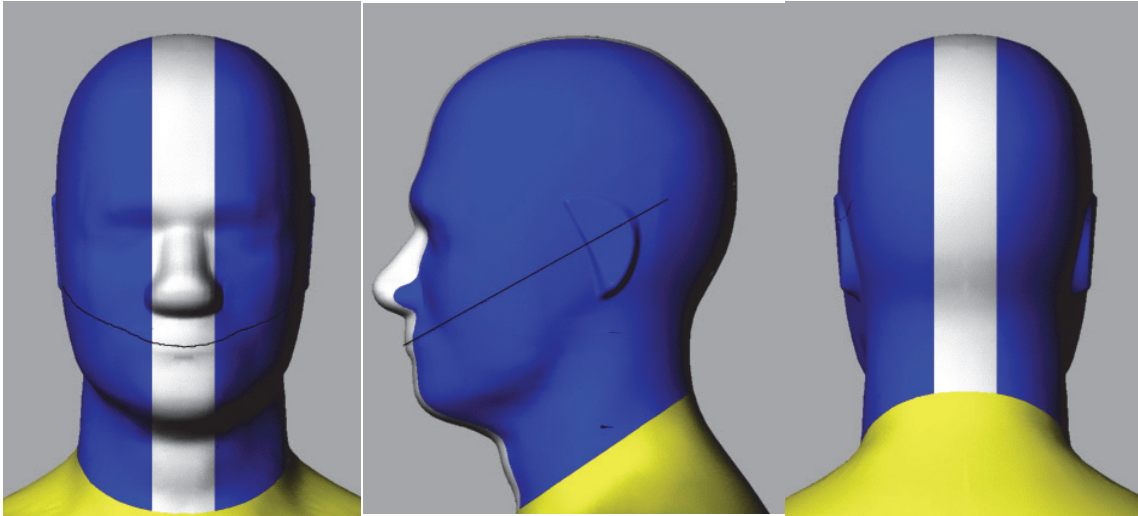

Figure C-2 combined with the text above, defines the shape and size of the external shell of the head phantom, but provision has to be made for filling/emptying the liquid contents and/or for sealing the base. No specific requirements are placed on the location of the hole(s) for filling/emptying the liquid contents of the head: these can be anywhere on or inside the head profile provided they do not obviously interfere with the measurements of this Test Plan. It is envisaged that either the top of the head or inside the neck region are the areas most likely to be used for this purpose. The plate that seals the base may incorporate the filling/emptying hole(s): this plate shall be made of a material with a dielectric constant of less than 5.0 and a loss tangent of less than 0.05. Whether containing the filling/emptying hole(s) (and the associated plug(s)/cap(s)/etc.) or serving as a mounting member, the plate shall additionally have a thickness of less than 13 mm and shall not extend beyond the external profile of the head phantom.

As an alternative head phantom, the IEEE SAM head model can be extended below the neck region so that its overall external height shall be 363 mm \pm 2 mm (without the filling cap). The external width of the base shall be symmetrically truncated to be 250 mm \pm 2 mm. The material in the extended region below 292 mm \pm 2 mm from the internal top of the IEEE SAM head shall have a dielectric constant of less than 5.0 and a loss tangent of less than 0.05. An additional uncertainty of 0.25 dB ($k=2$) shall be added [3].

The uncertainties caused by deviations from the nominal head shell dimensions shall be assessed as defined in Appendix G.10.2.

C.2.2 Head Phantom Dielectric Parameters

The IEEE Standards Coordinating Committee 34 has defined the dielectric properties of the head tissue-equivalent material to be used in the head phantom for SAR measurement. To provide consistency between SAR and TRP/TIS measurement, nearly identical material dielectric property values are to be used for this Test Plan. The target values are given in Table C-1; the tolerance is \pm 20%.

For dielectric properties of head tissue-equivalent material at other frequencies within the frequency range, a linear interpolation method shall be used.

Dielectric materials which only comply with the requirements over a portion of the 300 MHz to 6 GHz may be used but only for tests where the band/protocol being measured is within the frequency band of compliance.

TABLE C-1 DIELECTRIC PROPERTIES OF THE TISSUE-EQUIVALENT LIQUID

Frequency (MHz)	Target	
	ϵ	σ (S/m)
300	45.3	0.87
450	43.5	0.87
835	41.5	0.90
900	41.5	0.97
1450	40.5	1.20
1800	40.0	1.40
1900	40.0	1.40
1950	40.0	1.40
2000	40.0	1.40
2100	39.8	1.49
2450	39.2	1.80
3000	38.5	2.40
4000	37.4	3.43
5000	36.2	4.45
5200	36.0	4.65
5400	35.8	4.86
5600	35.5	5.06
5800	35.4	5.27
6000	35.1	5.48

Liquid tissue equivalent material may be used provided that the target dielectric properties are met within $\pm 20\%$. Solid tissue equivalent material will be allowed in a future release of this test plan.

The composition of the material is not mandated provided the target dielectric properties are met within the permitted interval.

Recipes for liquid tissue equivalent material are provided in IEEE Std 1528-2003 where the main components are deionized water and sugar. Liquids are available from third parties or can be mixed locally.

Care should be taken to verify the dielectric properties of the liquid tissue equivalent material at frequent enough intervals so as to guarantee compliance with the target ($\pm 20\%$) at the time of use for this Test Plan. Methods for measuring the dielectric properties are given in [Appendix H](#).

Alternatively, liquid tissue equivalent material can be replaced by gel, provided that the volume of all air bubbles in the material is below 0.13 cubic centimeters, and the dielectric properties of these materials

are stable with time and certified at the point of manufacture. Methods for measuring the dielectric properties are given in [Appendix H](#).

Solid tissue equivalent material can be made from carbon loaded silicone, the dielectric properties of these materials are stable with time but must be certified at the point of manufacture following the protocol defined for the hand, i.e., a cubical sample (approximately 50 mm x 50 mm x 50 mm) for verification of stability and bulk properties and surface measurements at >20 defined positions on both sides of the head. Manufacturers of solid material head phantoms must certify that the volume of all air bubbles in the material must be below 0.13 cubic centimeters. For the purposes of this test plan, the remaining air bubbles can be assumed to have a negligible effects on the TRP/TIS.

Note: *Due to the inability to assess the measurement uncertainty of the solid tissue equivalent material for the head phantom, the use of solid head phantoms is not allowed in the test plan at this time.*

The uncertainties caused by deviations from the nominal head dielectric parameters shall be assessed as defined in [Appendix G.10.2](#).

C.2.3 Head Fixturing Requirements

The primary goal of the fixture is to allow the accurate positioning of the EUT, while also being transparent and non-reflective to RF. The material for the EUT fixturing shall have a dielectric constant of less than 5.0 and a loss tangent of less than 0.05. Any fixture meeting these material parameters may be used as long as the uncertainty assessment is done and the overall uncertainty budget is met.

The method for assessing the uncertainty for the hand phantom fixturing is described in [Appendix G.10.4](#) and can also be used for assessing the uncertainty for head fixturing.

No additional uncertainty assessment is needed if thin plastic “packing” tape is used to hold the EUT.

C.3 Hand Phantom—Reference Information

The human hand is one of the most complex parts of the human body. Detailed hand geometry not only varies from person to person, but the hand will change geometrically depending on the physical task assigned to it. Since mobile devices are used in conjunction with the hand, it is important that the hand is studied to determine the best scientific representation of the specific dimensions for a standard sized hand phantom. A large amount of published data exists regarding the human hand, but few papers address anthropometry of the hand.

C.3.1 Hand Anthropometric Research

The following articles contain information that is significant in determining the physical dimensions of a hand phantom and are used in conjunction with each other in the determination of the hand dimension parameters.

- Thomas M. Greiner; *Hand Anthropometry of US Army Personnel*, Army Natick Research Development and Engineering Center, 1991 - This study, sponsored by the Anthropology Branch at NATICK, is perhaps the largest and most comprehensive modern anthropometric study available. A sample size of 2304 people and 86 anthropometric categories were photographed, digitized, and measured. Measurements were taken from

- a number of landmarks on the hand, including creases in the skin of the hand, the tips of fingers, and other visible locations.
- Alvin R. Tilley and Henry Dreyfuss Associates; *The Measure of Man and Woman: Human Factors in Design*; Wiley, 1993 - This book contains some additional data regarding hand anthropometry to supplement the Greiner study. Although the Greiner study is mentioned, the source of the additional data in the book is unfortunately not referenced.
 - B. Buchholz, T.J. Armstrong and S.A. Goldstein; "Anthropometric data for describing the kinematics of the human hand," *Ergonomics* vol. 35, no. 3, pp. 261-273, 1992 - This article identifies the locations of the internal rotational joints of the fingers with respect to the skin creases that are used as measurement references in the previous two studies. This information is required to develop an articulated kinematic hand model that can be posed with anatomically correct bends in the joints.
 - W.D. Bugbee and M.J. Botte.; "Surface Anatomy of the Hand: The Relationships Between Palmar Skin Creases and Osseous Anatomy," *Clinical Orthopaedics and Related Research*, 296, 122-126, 1993 - This study was performed on 48 adult corpse hands and 5 live human hands. It supplements the Buchholz article with additional data on the relationship between skin creases and internal bone structure, and especially for modeling distinct carpal and metacarpal bones.

C.3.2 Hand Reference Dimensions

Based on the analysis above, the necessary dimensions of the hand components were determined. Since no one study contains all of the necessary dimensions, some combining and scaling was performed using all four references.

The hand phantom is the average of the 50th percentile of men and women as taken from the data sources cited above. The full data set including averaged hand data (per gender) and skin crease to bone joint scaling factors can be found in the references.

The hand phantom dimensions are defined in [Table C-2](#).

TABLE C-2 HAND PHANTOM DIMENSIONS

Description	Dim. (mm)	Notes
Interdigital Crotch Dimensions		
Between Digit II & III Crotch to Tip of Digit II	72.5	Greiner #10
Between Digit II & III Crotch to Tip of Digit III	80.5	Greiner #22
Between Digit III & IV Crotch to Tip of Digit IV	75.7	Greiner #34
Between Digit IV & V Crotch to Tip of Digit V	61.5	Greiner #46
Between Digit I & II Crotch to Tip of Digit I	56.5	Tilley
Major Hand and Wrist Dimensions		
Wrist Width	61.4	Greiner #64
Wrist Circumference	162.9	Greiner #65
Hand Length, Center of Wrist to Tip of Digit III	186.5	Greiner #24
Hand Circumference	200.2	Greiner #60
Palm Length: Middle Crease to Distal Palm Crease	105.7	Greiner #61
Hand Width	85.0	Greiner #63

TABLE C-2 HAND PHANTOM DIMENSIONS

Description	Dim. (mm)	Notes
Digit I Dimensions		
Distal Phalanx Length	29.4	Buchholz, Greiner
Proximal Phalanx Length	36.5	Buchholz, Greiner
Metacarpal Length	46.8	Buchholz, Greiner
Carpal Length	22.0	Buchholz, Greiner
DIP Width	22.3	Greiner #4
DIP Circumference	67.7	Greiner #5
Digit II Dimensions		
Distal Phalanx Length	18.1	Buchholz, Greiner
Middle Phalanx Length	26.7	Buchholz, Greiner
Proximal Phalanx Length	45.7	Buchholz, Greiner
Metacarpal Length	67.4	Buchholz, Bugbee
DIP Width	18.7	Greiner #15
PIP Width	21.5	Greiner #13
DIP Circumference	54.1	Greiner #16
PIP Circumference	64.8	Greiner #14
Carpal Length	20.6	Buchholz, Bugbee
Digit III Dimensions		
Distal Phalanx Length	20.1	Buchholz, Greiner
Middle Phalanx Length	31.7	Buchholz, Greiner
Proximal Phalanx Length	49.6	Buchholz, Greiner
Metacarpal Length	66.2	Buchholz, Bugbee
DIP Width	18.5	Greiner #27
PIP Width	20.9	Greiner #25
DIP Circumference	54.4	Greiner #28
PIP Circumference	65.5	Greiner #26
Carpal Length	17.4	Buchholz, Bugbee
Digit IV Dimensions		
Distal Phalanx Length	20.0	Buchholz, Greiner
Middle Phalanx Length	30.8	Buchholz, Greiner
Proximal Phalanx Length	45.5	Buchholz, Greiner
Metacarpal Length	60.4	Buchholz, Bugbee
DIP Width	17.2	Greiner #39
PIP Width	19.9	Greiner #37
DIP Circumference	50.3	Greiner #40
PIP Circumference	61.2	Greiner #38
Carpal Length	19.4	Buchholz, Bugbee

TABLE C-2 HAND PHANTOM DIMENSIONS

Description	Dim. (mm)	Notes
Digit V Dimensions		
Carpal Length	24.3	Buchholz, Bugbee
Distal Phalanx Length	17.3	Buchholz, Greiner
Middle Phalanx Length	21.8	Buchholz, Greiner
Proximal Phalanx Length	38.0	Buchholz, Greiner
Metacarpal Length	56.6	Buchholz, Bugbee
DIP Width	16.1	Greiner #51
PIP Width	17.9	Greiner #49
DIP Circumference	45.9	Greiner #52
PIP Circumference	54.2	Greiner #50

FIGURE C-3 PICTORIAL OF HUMAN HAND WITH DIMENSION LABELS

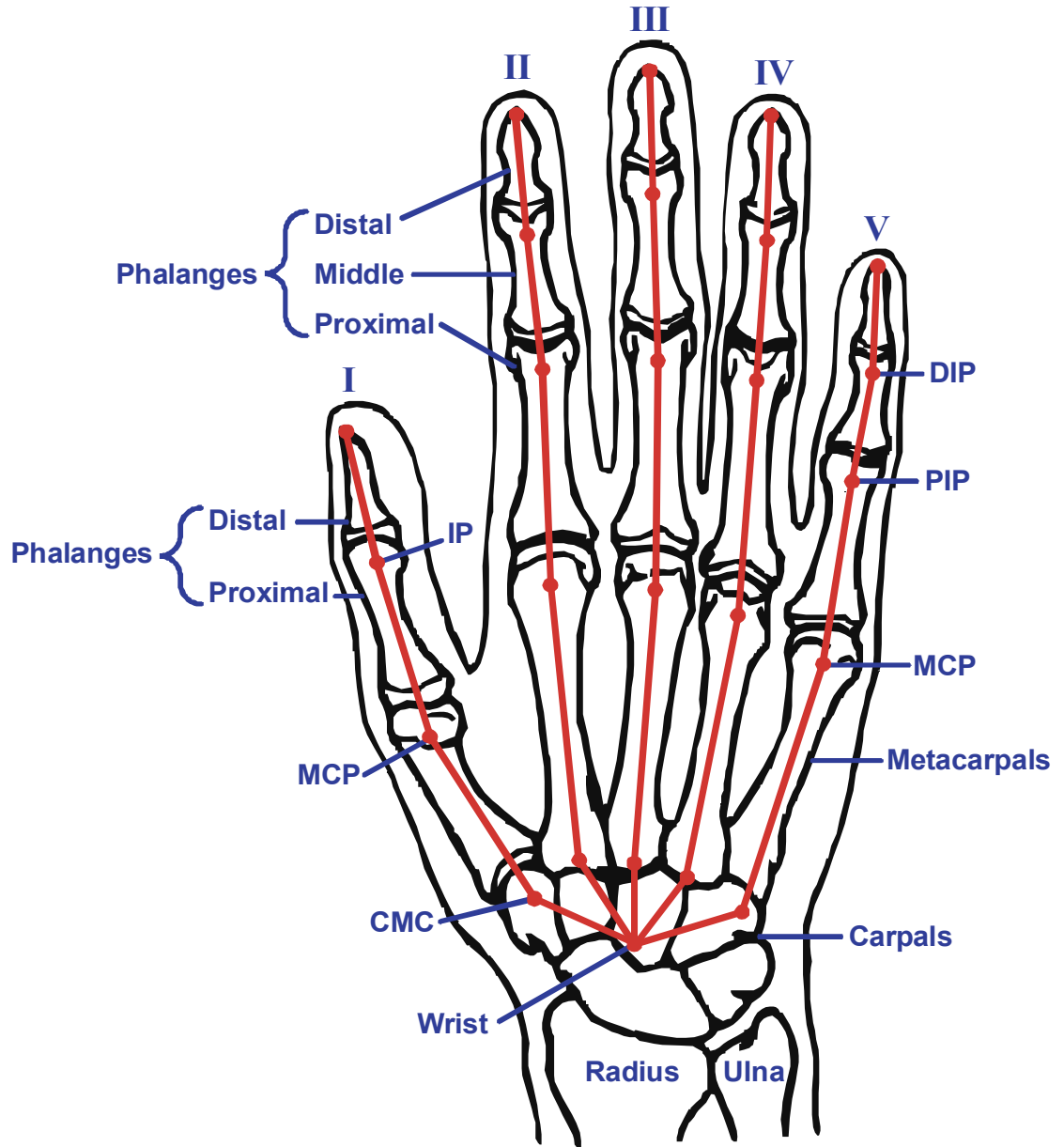
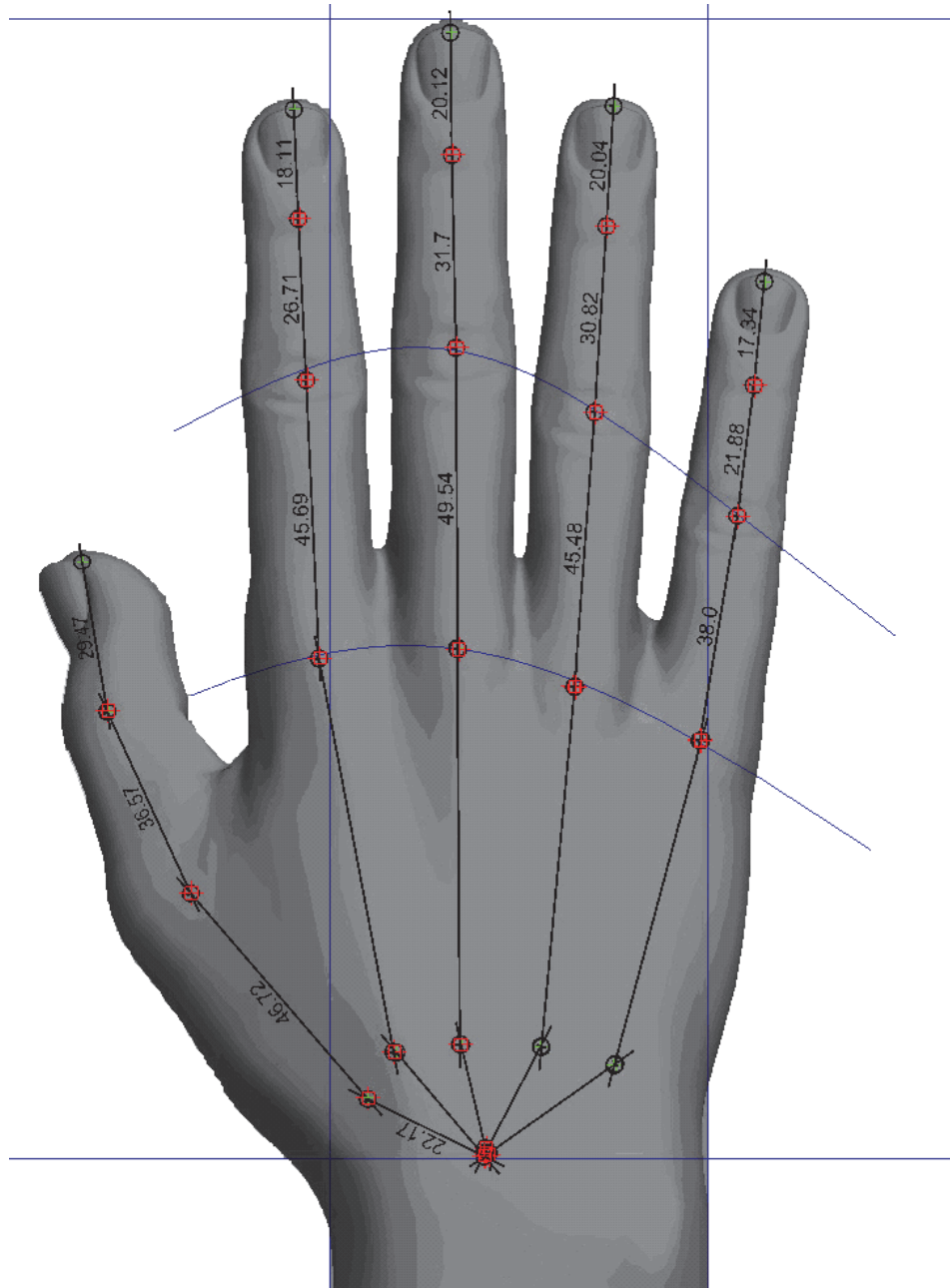

FIGURE C-4 OPEN HAND PHANTOM



C.3.3 Hand Reference Dielectric Parameters

RF dielectric properties of the hand phantom are based on the dry palm human tissue measurement data as discussed in “*Tissue Equivalent Material for Hand Phantoms* [4].” Table C-3 lists the target conductivity (σ) (S/m) and relative permittivity (E_r) for the hand phantom from 300 MHz to 6 GHz.

TABLE C-3 HAND DIELECTRIC PARAMETERS

Frequency (MHz)	E_r	σ (S/m)
300	37.1	0.36
450	33.9	0.43
835	30.3	0.59
900	30.0	0.62
1450	27.9	0.85
1575	27.5	0.90
1800	27.0	0.99
1900	26.7	1.04
1950	26.6	1.07
2000	26.5	1.09
2100	26.3	1.14
2450	25.7	1.32
3000	24.8	1.61
4000	23.5	2.18
5000	22.2	2.84
5200	22.0	2.98
5400	21.7	3.11
5600	21.4	3.25
5800	21.2	3.38
6000	20.9	3.52

The material composition of the hand phantom is typically silicon loaded with carbon powder. The exact ratios of these compounds are not critical as long as the required RF dielectric properties are met.

C.4 Hand Phantom Definitions and Requirements

Contact cpwg@ctiacertification.org to obtain hand phantom-related CAD files.

Companies interested in manufacturing hand phantoms should contact CTIA Certification at programs@ctiacertification.org to obtain additional dielectric parameter information on the existing hand phantoms in order to best align the OTA performance impact of new hand phantoms with the OTA performance impact of the existing hand phantoms.

C.4.1 Dielectric Parameter Requirements

The relative permittivity of hand phantoms shall be within $\pm 15\%$ of the values listed in [Table C-3](#). The conductivity of hand phantoms shall be within $\pm 25\%$ of the values listed in [Table C-3](#). The dielectric parameters shall be determined as described in [Appendix G.10.3](#) using the methods in [Appendix H](#), across the frequency bands for which the hand phantom is to be used. The RF dielectric parameters may be certified by the hand phantom manufacturer or determined by the test lab. The manufacturer shall provide a certificate indicating compliance over the applicable bands, including the measurement methodology and results, when they are certifying compliance with the RF dielectric parameters.

Dielectric materials which only comply with the requirements over a portion of the 300 MHz to 6 GHz may be used but only for tests where the band/protocol being measured is within the frequency band of compliance.

C.4.2 Hand Phantom Identification

The hand phantoms shall be traceable by their model and serial number. Hand phantom manufacturers shall provide a reference material block made of the same material as its associated hand phantoms, which is suitable for measuring its dielectric properties (see [Appendix G.10.3](#)). Each hand phantom shall be traceable to its associated reference material block. The identification marking of the hand phantom shall be on the back half of the hand, on the wrist, or on any side/rear mounting boss permanently attached to the hand, specifically in an area where there is no chance of interaction with the OTA measurement.

C.4.3 Hand Mechanical Requirements

The hand phantoms shall be constructed of a material that is sufficiently flexible to accommodate the range of devices specified in [C.4.5](#), [C.4.6](#), [C.4.7](#), and [C.4.8](#). The material shall also be made sufficiently stiff that the hand grip remains constant under rotation. Adequate material stiffness of the hand phantom has been found to be necessary to maintain high repeatability of OTA measurements.

The stiffness of the hand material shall be verified by measuring the deflection of the index finger of a molded monoblock hand phantom under a given weight.

1. Position the hand phantom such that the index finger is horizontal.
2. Apply an indicator needle that extends horizontally 55 mm \pm 1 mm beyond the tip of the index finger.
3. Record the position of the indicator needle on a vertical scale.
4. Apply 20 g \pm 0.2 g of weight centered 6 mm \pm 0.5 mm from the tip of the index finger towards the hand.
5. Record the new position of the indicator needle on a vertical scale.

The deflection of the index finger of the hand phantom shall be between 2 and 5 mm. Deflection less than 2 mm per 20 g weight indicates a material that is too rigid. Deflection greater than 5 mm per 20 g weight indicates a material that is too soft.

[Figure C-5](#) shows a conformal fingertip weight container with indicator needle that shall be used for this purpose.

FIGURE C-5 CONFORMAL FINGERTIP WEIGHT CONTAINER

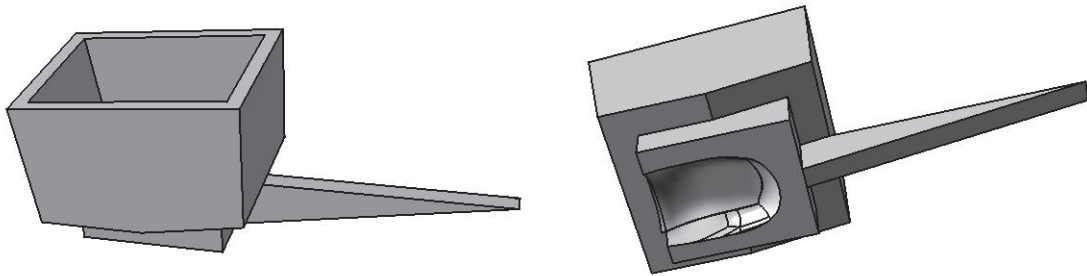

The weight container is fastened to the index fingertip with cellophane tape and the hand phantom is laid on its back on a flat surface, with the indicator needle pointing to a vertical millimeter ruler as shown in [Figure C-6](#). The position of the needle is recorded before and after a known weight is placed in the container, and the difference is calculated to determine the deflection under load.

FIGURE C-6 MEASURING THE HAND PHANTOM MATERIAL STIFFNESS

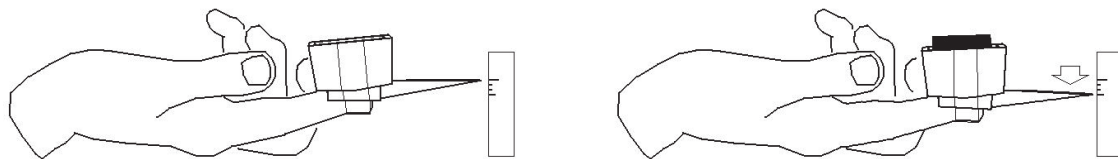

It is assumed that the other hand phantoms (i.e., fold, narrow data and PDA grips) will have similar stiffness as the monoblock hand from the same material. Therefore, a stiffness test of the monoblock hand alone is considered sufficient.

C.4.4 Hand Phantom Fixturing Requirements

The primary goal of the fixture is to allow the accurate positioning of the hand phantom and EUT, while also being transparent and non-reflective to RF. The material for the hand phantom fixturing shall have a dielectric constant of less than 5.0 and a loss tangent of less than 0.05. Any fixture meeting these material parameters may be used as long as the uncertainty assessment is done and the overall uncertainty budget is met.

The method for assessing the uncertainty for the hand phantom fixturing is described in [Appendix G.10.4](#).

C.4.5 Monoblock Hand Phantom

The monoblock hand phantom is suitable for use with monoblock EUTs and closed portrait slide/rotator EUTs for head and hand testing. The EUTs should have sizes within the ranges specified within [Table C-4](#).

TABLE C-4 RANGE OF MONOBLOCK-LIKE DEVICE SIZES SUITABLE FOR USE WITH MONOBLOCK HAND PHANTOM

Feature	Minimum (mm)	Maximum (mm)
Width	40	56
Length	95	none

FIGURE C-7 MONOBLOCK HAND PHANTOM; (A) LEFT HAND; (B) RIGHT HAND

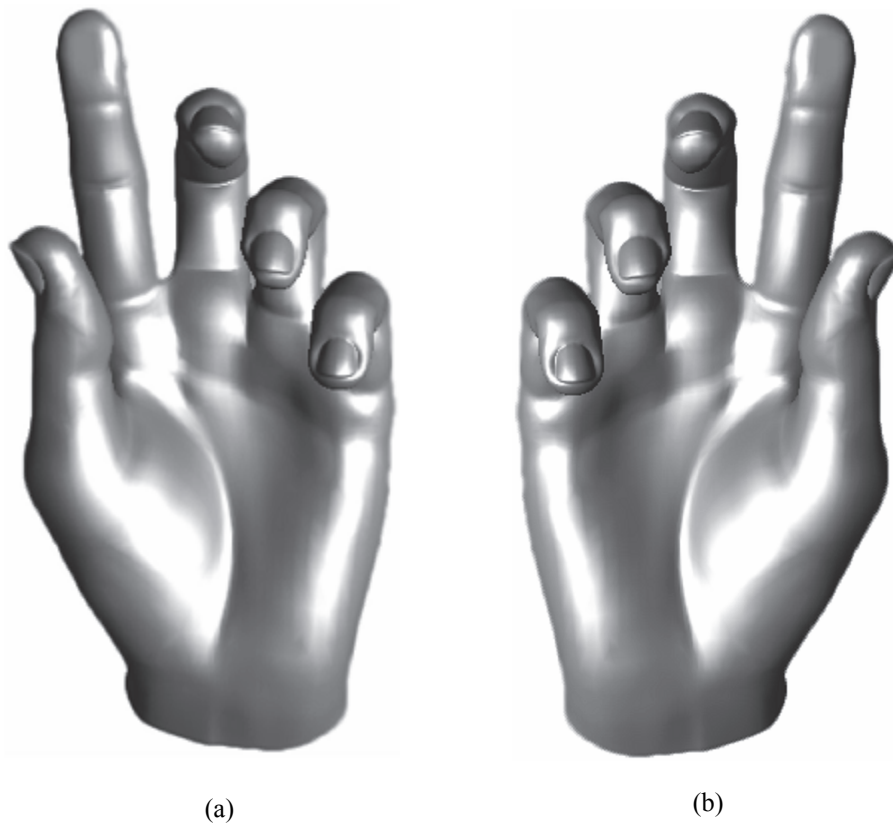

C.4.6 Fold Hand Phantom

The fold hand phantom is suitable for use with fold and open portrait slide/rotator EUTs for head and hand testing, with sizes within the ranges specified within [Table C-5](#).

TABLE C-5 RANGE OF FOLD DEVICE SIZES SUITABLE FOR USE WITH FOLD HAND PHANTOM

Feature	Minimum (mm)	Maximum (mm)
Width	40	56
Length between hinge and bottom edge	75	none

FIGURE C-8 FOLD HAND PHANTOM; (A) LEFT HAND; (B) RIGHT HAND

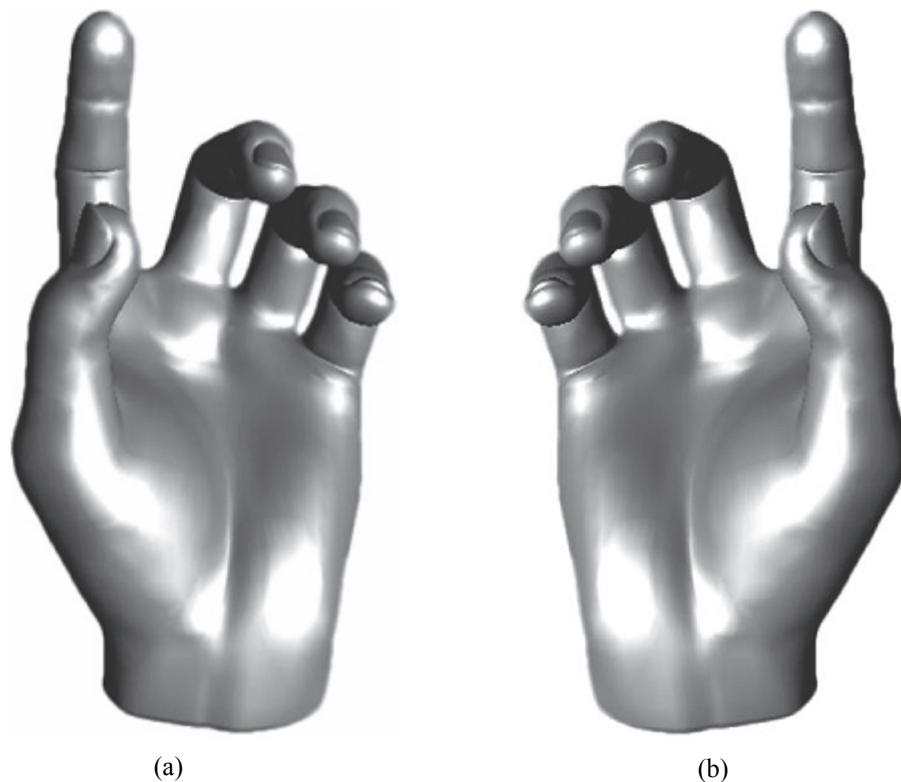

C.4.7 Narrow Data Hand Phantom

The narrow data hand phantom is suitable for use with narrow EUTs with sizes within the ranges specified within [Table C-6](#) for hand only testing.

TABLE C-6 RANGE OF NARROW DATA DEVICE SIZES SUITABLE FOR USE WITH NARROW DATA HAND PHANTOM

Feature	Minimum (mm)	Maximum (mm)
Width	40	56
Thickness	none	26

FIGURE C-9 NARROW DATA HAND PHANTOM; (A) LEFT HAND; (B) RIGHT HAND

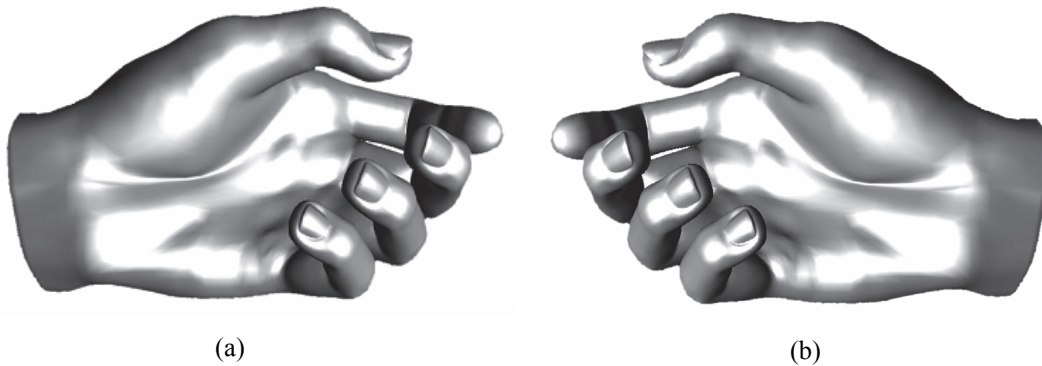

C.4.8 PDA Grip Hand Phantom

The PDA grip hand phantom is suitable for use with EUTs with sizes within the ranges specified within [Table C-7](#) for head and hand testing or hand only testing.

TABLE C-7 RANGE OF PDA DEVICE SIZES SUITABLE FOR USE WITH PDA HAND PHANTOM

Feature	Minimum (mm)	Maximum (mm)
Width	56	72
Thickness	none	none

FIGURE C-10 PDA HAND PHANTOM; (A) LEFT HAND; (B) RIGHT HAND

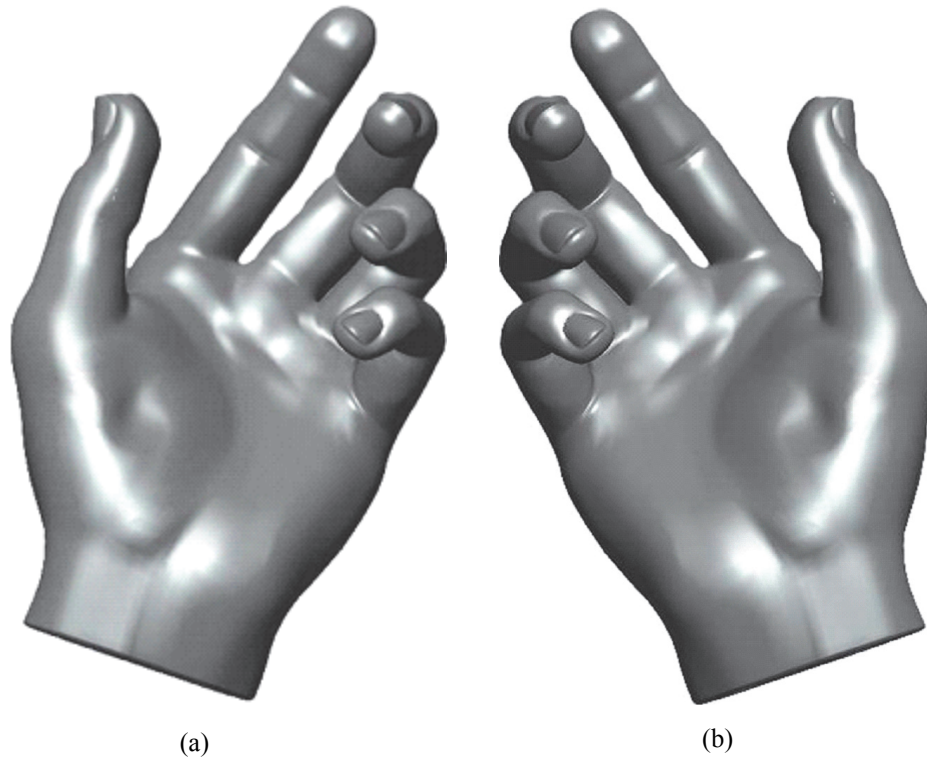

C.4.9 Wide Grip Hand Phantom

The Wide Grip hand phantom is suitable for use with an EUT having physical dimensions falling within the ranges specified by [Table C-8](#) for “talk” mode (head and hand) or “data” mode (hand-only) testing.

TABLE C-8 RANGE OF EUT SIZES SUITABLE FOR USE WITH WIDE GRIP HAND PHANTOM

Dimension	Minimum (mm)	Maximum (mm)
Width	>72	92
Thickness	none	none

FIGURE C-11 WIDE GRIP HAND PHANTOM; (A) LEFT HAND, (B) RIGHT HAND

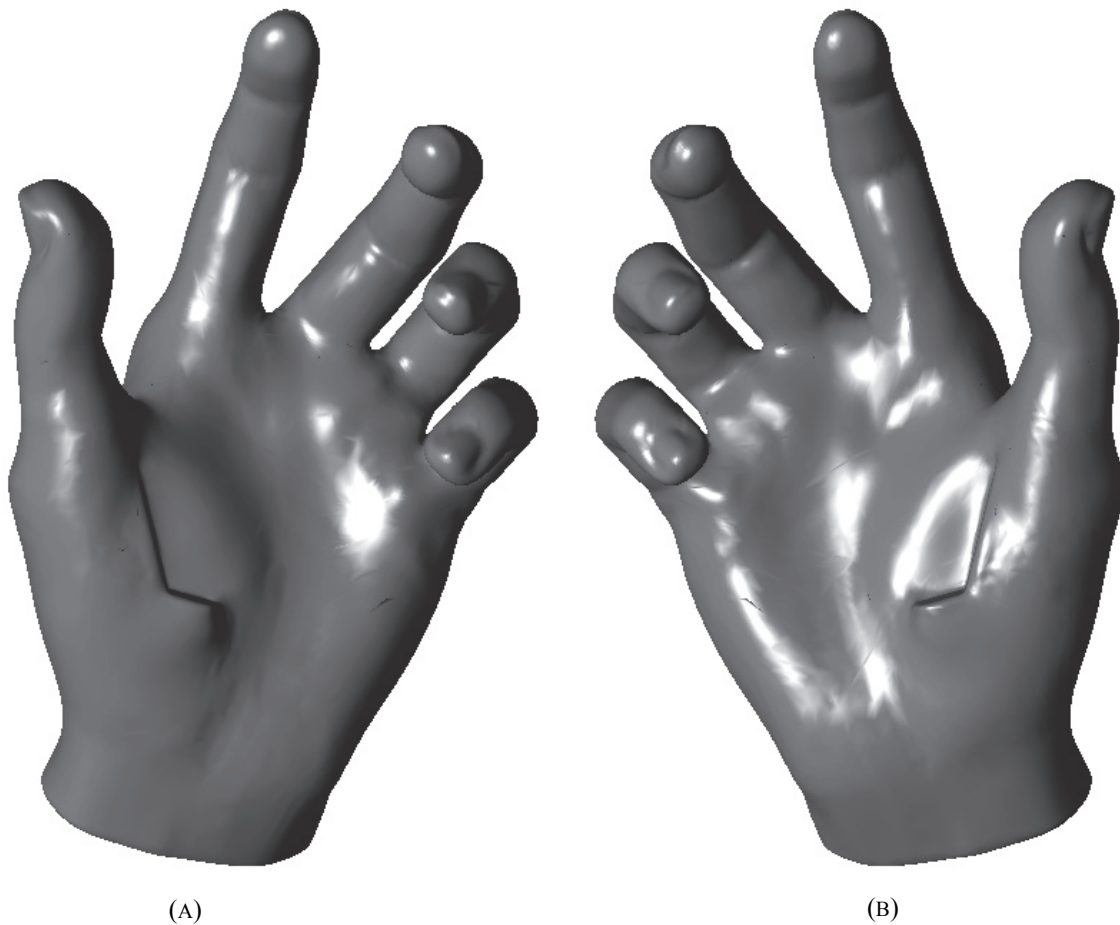

C.4.10 Alternative Hand Phantoms

Alternative hand phantoms will be allowed in the future for EUTs with form factors or sizes not covered by the current hand phantoms. These new alternative hand phantoms shall be based on human factor studies. However, the method for performing and approving these human factor studies will be determined in a future update. These alternative hand phantoms shall be based upon the existing parameters outlined in [Appendix C.3.2](#) and [Appendix C.3.3](#). All new approved hand phantoms along with their corresponding human factors studies shall be published through CTIA Certification after the associated EUT is launched in the US, thus making them available for public use.

The testing of devices with alternate hand phantoms is currently not required in this test plan.

Appendix D Power Measurement Considerations (Normative)

D.1 Power Measurement Equipment

In order to perform the power measurements required by this test, there are a number of considerations to take into account with regard to the test equipment used for these measurements. The recommended equipment for these power measurements is a spectrum analyzer, base station simulator, or power meter. Any selected instrumentation should be specifically designed for measurement of wireless modulated waveforms.

Modern spectrum analyzers provide direct control over the parameters necessary to measure different communications signals and can make the required measurements with relatively low uncertainty contributions. However, older units may not be capable of performing the measurements within the tolerance necessary to meet the overall uncertainty requirement. For units with sufficient linearity and stability, it may be possible to use a transfer standard from a power meter or other more accurate device during the Range Reference Measurement to reduce the total uncertainty associated with the analyzer.

Base station simulators are convenient for use in power measurements since their receiver settings are normally correctly pre-configured for each protocol. Thus, the detailed considerations presented in [Appendix D.3](#) through [Appendix D.8](#) have in general been handled by the manufacturer of the base station simulator. Another convenience is that the base station simulators are commonly used for conducted power measurements and the use of the same equipment for the TRP measurement facilitates consistent comparisons between conducted and radiated performances. Commonly used base station simulators are designed for conducted tests and require additional amplifiers to deal with the additional path losses associated with radiated tests.

Power meters are inherently broadband measurement receivers and as such require special precautions when used to measure OTA TRP. Modern power meters employ sampled diode detectors and digital signal processing techniques to enhance measurement accuracy and dynamic range. Detector video bandwidths have been extended to allow measurement of modulated wireless communications signals. Triggering capability has been improved to allow triggering from and measurement of burst modulated signals. These capabilities make power meters a viable alternative for OTA TRP measurement.

Other receivers may also be used to measure the received power provided it can be shown that they meet the necessary sensitivity, frequency discrimination, and waveform requirements for the respective communication technology.

D.2 General Measurement Requirements

This section lists general requirements and recommendations that should be addressed for all technologies and power measurement technologies. The primary goal is to insure that uniform total radiated power measurements can be made within the expected uncertainty of the given device. The remaining sections of this appendix contain the specific requirements for the individual technologies. Those sections assume the use of a spectrum analyzer or a power meter for the required measurements, although other receiver technologies may be used provided they are shown to produce equivalent results. Unless otherwise noted, RMS detector mode is assumed for the spectrum analyzer.

As with all RF measurements, special attention must be paid to the noise floor and compression levels of the instrumentation used. The wide dynamic range of signals expected for a typical ERP pattern measurement makes this difficult. The pulsed nature of wireless communication also places special demands on components such as preamplifiers and receiver front ends, which may perform fine for CW signals but produce harmonics or distortion for pulsed signals. The manufacturer's documentation for all components should be consulted to ensure that the expected level of performance can be obtained.

It is recommended that the peak signal received for a pattern be at least 40 dB above the noise floor. For a dipole this would result in a noise contribution of approximately 0.12 dB to the TRP, and just under 0.1 dB to the peak EIRP points. For antenna ranges for which the path loss would result in signal levels below this limit, either an appropriate preamplifier may be used (incorporating the necessary drift and linearity terms into the uncertainty budget), or the uncertainty budget must be increased to reflect the larger uncertainty due to the proximity to the noise floor. However, the total uncertainty of the measurement system may not exceed the limit given in [Section 1.1](#). In no case shall the peak signal for a pattern be allowed to be within less than 20 dB (1.1 dB dipole TRP error) of the peak noise floor (i.e. the total usable dynamic range must be greater than 20 dB) since the corresponding loss in resolution would reduce the usefulness of the EIRP pattern for comparison purposes

Due to the modulated nature of the communication signal, specific dwell times are necessary to ensure repeatable measurements. The spectrum analyzer, power meter, or receiver must be able to support the required sweep times and specified number of uncorrelated data points to obtain the required measurement resolution for each technology. Software or firmware used to process the data must apply the appropriate digital filters to produce the required result.

Note: Any external attenuation or amplification added to meet the above requirements must be included in the Range Reference Measurement, or added into the range correction as separate terms, and appropriate adjustments must be made to the total measurement uncertainty.

For alternate receivers and power meters, they must support equivalent bandwidth and filter settings or functions that produce measurement results equivalent to those listed here.

D.2.1 Use of Spectrum Analyzers

While a number of newer spectrum analyzers are actually swept tuned receivers with appropriate spectrum displays and bandwidth filters, the traditional spectrum analyzer consists of a spectrum display that is tied to the output bits of the receiver's analog-to-digital converter (ADC). Different detectors are used to process each sample from the ADC to generate each data point on a trace. The sample detector takes a single ADC reading at each time or frequency point along a trace and returns that value as the displayed value. For other detectors, the ADC typically samples at some maximum rate and a processed result is displayed for each data point (commonly referred to as a "bin"). The number of samples taken per data point is given by the sweep time divided by the total number of points in the sweep and by the sample rate of the ADC. A peak detector returns the maximum value sampled during the portion of the sweep centered around each data point, while the RMS detector returns a linear average power of the available samples. Longer sweep times typically result in more samples per point and more accurate detector values. In addition to the sample rate of the ADC, the bandwidth filter will reduce the effective number of uncorrelated samples. The effective sample rate in samples per second is equivalent to the selected resolution bandwidth in Hz.

Since the vertical resolution of the display typically matches the available resolution of the ADC, the measured value is only accurate to the instrument specifications when the reading is within the graticule of the analyzer window. Points above or below that point are subject to compression and/or clipping effects that may not be apparent, especially when used with software automation. In addition, when using the RMS filter, the result can be biased even when the reported value is several dB from the top of the

window, since some samples within the average may be clipped, resulting in a lower average value. Due to these limitations, the reference level and attenuation of the analyzer must be adjusted so that maximum signal level received during the pattern testing stays within the graticule. It is recommended that the peak signal remains at least 5 dB below the top of the window to avoid clipping unexpected peaks in the pattern. For tuned receiver type units, the settings must be adjusted as required so that the peak expected signal does not overdrive the receiver. Refer to the manufacturer's documentation to determine if the spectrum analyzer readings reported to software automation are valid when the signal is outside the bounds of the display.

D.2.2 Use of Communication Testers

Base station simulators typically perform power measurements using a spectrum analyzer concept. The RF signal is down-converted to IF frequencies and processed using fast Digital Signal Processors (DSP). The bandwidth of the receiver filter is automatically set to that required by the respective protocol. E.g., for GSM a 500 kHz Gauss filter is used, while for CDMA the receiver filter is set to 1.23 MHz as defined in IS-2000.2. As mentioned previously, additional external amplifiers and/or filters are required to achieve sufficient dynamic range for radiated tests. Base Station Simulators with separate transmit and receive ports are most convenient for radiated tests. Otherwise, a single combined transmit/receive port would require a high isolation diplexer to split transmit and receive signals before amplification. In either case, it is important to verify that leakage from the output of the base station simulator does not adversely affect measurements on the input ports.

D.2.3 Use of Power Meters

Unlike spectrum analyzers, power meters are broadband power measurement devices. They will combine the power of all signals present at the sensor into a single amplitude level. However, power meters are simple and inexpensive compared to spectrum analyzers, and data acquisition speed can be significantly faster, reducing overall TRP measurement times. Careful system design is required to insure that measurement error due to unwanted signals is kept below specified levels.

When power meters are used for TRP measurement, it is required to show that the coupling of the forward link power into the measurement antenna does not significantly affect the measured power, and is accounted for appropriately in the uncertainty budget. The power sensor shall be assumed to report the signal level as the sum of the voltages present, and it is recommended that the measurement system provide a minimum of 45 dB of forward-to-reverse channel isolation to limit measurement error from this source to < 0.1 dB. Power meters not specifically designed or certified for wireless power measurements are prohibited.

Many sources of uncertainty impact the measurement of OTA TRP. These are covered in detail in [Section 7](#) and [Appendix G](#) of this test plan. Two sources of uncertainty require special attention when using power meters to determine OTA TRP:

- The ratio of reverse-to-forward signal level (P_r/P_f) present at the power meter sensor
- The ratio of reverse signal level-to-noise (P_r/N) present at the power meter sensor

D.2.3.1 Ratio of Reverse-to-Forward Signal Level

A base station simulator (wireless communication test set) is used to place the handset into a call on a specified channel and at a specified reverse channel power level. At least one forward channel is

required for handset control and forward traffic. In any practical OTA test chamber, some of the forward channel energy will couple into the measurement antenna and will be present at the measurement receiver. If the receiver is a broadband power meter, the sensor will respond to the forward channel energy as well as the reverse channel energy, producing measurement uncertainty. This source of uncertainty must be quantified and controlled.

TRP measurement uncertainty attributed to forward link power should be no greater than 0.1 dB. The level of isolation P_r/P_f required to achieve this uncertainty level is dependent on the characteristics of both the power sensor used and the signals being measured. Modern power meters use diode sensors almost exclusively. Diode sensors respond to voltage; they do not convert power to thermal energy. The power level reported with multiple signals present will depend on the level of coherency between the various signals. In the worst case, the diode sensor will add the peaks of the signals on a voltage basis. In this case, $P_r/P_f > 45$ dB is required to achieve an uncertainty level $U < 0.1$ dB.

In an OTA chamber, the forward path from the base station to the handset is established either through the measurement antenna, or through an auxiliary antenna mounted in the chamber for this specific purpose. In either case, some of the forward channel energy will couple into the measurement receiver. It is instructive to examine these two system configurations to determine if the forward signal level can be controlled to be greater than 45 dB below the reverse signal level expected during TRP measurements.

Figure D-1 shows a simplified diagram of an OTA system where the forward path is established using an auxiliary antenna. For purposes of discussion, the auxiliary antenna is assumed to be located directly behind the handset and in line with the measurement antenna. It is also assumed that the forward and reverse channel signals are co-polarized.

FIGURE D-1 USE OF AUXILIARY ANTENNA FOR FORWARD CHANNEL

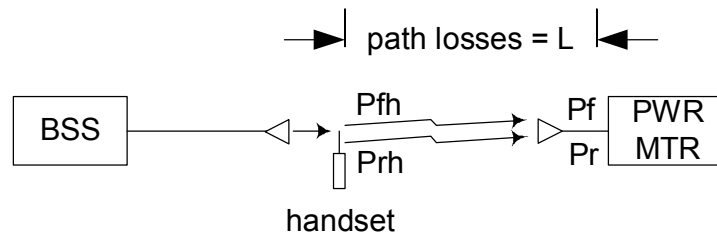

In this configuration, the forward channel signal will propagate past the handset and directly into the measurement antenna, a worst-case situation. Assume that the forward signal level arriving at the handset is P_{fh} and that the reverse signal level transmitted by the handset in the direction of the measurement antenna is P_{rh} . Since both the forward and reverse channel signals must travel over the same path through the measurement antenna to the power meter sensor, and since both will be in the same frequency range, both will be attenuated by the same amount when they arrive at the power meter sensor. Thus, the ratio P_r/P_f at the sensor will be the same as the ratio P_{rh}/P_{fh} at the handset.

For typical handsets, P_{fh} must be in the range -80 to -50 dBm to maintain a connection with the handset. Similarly, P_{rh} is typically in the range 0 to + 30 dBm, depending on the spatial orientation of the handset. Thus:

EQUATION D.1

$$10 \cdot \log(P_r/P_f) = 10 \cdot \log(P_{rh}/P_{fh}) = P_{rh}(\text{dB}) - P_{fh}(\text{dB}) = 50 \text{ to } 110 \text{ dB}$$

This range of values shows that this system configuration can satisfy the 45 dB isolation requirement.

Figure D-2 shows a simplified diagram of an OTA system where the forward path is established through the measurement antenna. A power splitter/combiner is used to couple the base station simulator to the measurement antenna for handset control. The power meter is connected to the opposite port of the splitter/combiner to measure the reverse channel signal transmitted by the handset.

FIGURE D-2 USE OF MEASUREMENT ANTENNA FOR FORWARD CHANNEL

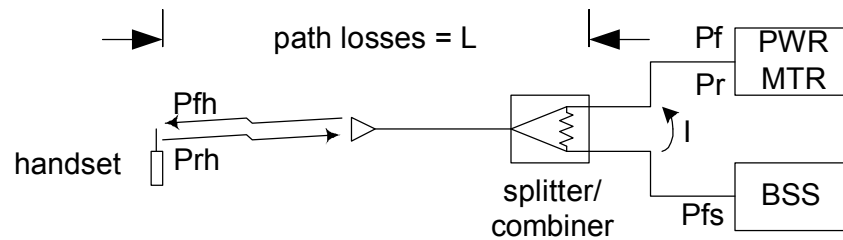

In this configuration, the forward channel signal travels to the handset over the same path as the reverse channel signal and will experience approximately the same losses denoted as L . The forward channel signal level appearing at the power meter sensor is dependent on the isolation of the splitter/combiner used, denoted as I . The ratio P_r/P_f can be expressed as:

EQUATION D.2

$$10 \cdot \log(P_r/P_f) = 10 \cdot \log((P_{rh} \cdot I)/(P_{fh} \cdot L^2)) = P_{rh}(\text{dB}) - P_{fh}(\text{dB}) - 2 \cdot L(\text{dB}) + I(\text{dB})$$

Using the same range of values for P_{rh} and P_{fh} as was used above, and assuming $L=40$ dB and $I=30$ dB:

$$10 \cdot \log(P_r/P_f) = 0 \text{ to } 60 \text{ dB}$$

This range of values shows that this system configuration probably will not satisfy the 45 dB isolation requirement for all spatial orientations of the handset.

D.2.3.2 Ratio of Reverse Signal Level-to-Noise

Appendix D.2 above requires that the peak handset EIRP level must be at least 20 dB above the system noise floor and it is recommended that the peak level be at least 40 dB above the system noise floor.

Power meters using diode detectors as the power sensor are available with residual noise floors of -70 dBm or less. Diode detectors produce an output voltage proportional to input power level. Below about -30 dBm, the output voltage is proportional to the square root of the input power; at higher power levels the response becomes highly nonlinear and can vary significantly from device to device. To maximize instrument operating range, newer power meters have built in calibration circuitry which calibrates the sensor for operation in the nonlinear range from -30 to +20 dBm. Thus the working dynamic range of these power meters is 90 dB.

In order to meet the noise floor requirements stated above, the peak EIRP level present at the power meter detector must be at least -50 dBm, with a recommended level of -30 dBm. These levels can be achieved with current OTA system configurations.

Wireless communications systems in use today use digital modulation techniques almost exclusively. These complex modulation formats are generally transmitted as a burst (GSM) or as a spread spectrum signal resembling noise (CDMA). Accurate measurement of the power level of these signals requires sampling the signal at a fast enough rate to reproduce the signal. For burst modulated signals, it is necessary to synchronize the duration of the measurement to the burst so that only the significant central region of the burst is captured. For spread spectrum signals, the signal must be sampled over the full extent of the channel spectrum to capture the true peak and average power levels.

The complex nature of wireless signals originally required the use of high speed sampling spectrum analyzers (or base station simulators) to accurately measure the levels of the signals transmitted by a mobile handset. However, newer power meters from several manufacturers have been designed specifically for wireless modulation formats. Power meters used for OTA TRP tests shall meet or exceed the following requirements:

- Minimum sampling rate of 2.5 MHz.
- Triggering modes to allow triggering from the rising edge of a burst modulated signal.
- Gating, delay and holdoff features to allow selection of the central region of pulses and bursts and collection of over 750,000 data samples over the selected region.
- Power sensors specifically designed for measurement of wireless modulation formats with wide video bandwidths.

D.3 TDMA

This section was removed for V3.1.

D.4 GSM/GPRS (GMSK Modulation)

GSM Circuit Switched and GPRS Packet Switched modes use a constant envelope modulation known as Gaussian Minimum Shift Keying (GMSK) that encodes one bit per symbol. The signal is slotted into 8 timeslots of approximately 0.577 ms with 148 symbols per slot.

For the purposes of characterizing antenna performance, the minimum required power measurement is given by the linear average of at least 1100 samples across the central 85% of a single valid GMSK burst (corresponding to approximately 5 samples per symbol). This is typically accomplished using the RMS detector of a spectrum analyzer with a sample resolution of 450 ns or better. Alternatively, the average of more than one burst may be used to reach the required sample count using either the RMS or sample detectors. In no case shall the sample rate be less than the symbol rate (270,833 symbols/s). The linear average of multiple bursts may also be used to reduce the random component of the uncertainty due to any variation in pulse magnitude. For multi-slot GPRS signals, the linear average of the center 85% of all active timeslots in one cycle should be used. A valid burst is defined as one having a width of 0.577 ms $\pm 10\%$. The spectrum analyzer must be set for zero-span using video or burst triggering with resolution and video bandwidths of 300 kHz. The trigger level should be set as close to the noise floor as possible without generating spurious triggers (typically 5-10 dB above the noise). For single timeslot measurements of a single pulse, the sweep time should be set such that the pulse takes up the majority of the available analyzer window. A setting of 0.6 ms is recommended. For multi-slot measurements, the span can be set to just larger than the total number of timeslots to be measured. Ideally there should

be at least 100 points per timeslot to ensure that the center 85% of each timeslot can be easily determined.

If a power meter is used, it must be capable of triggering from and measuring burst modulated signals with complex modulation formats. It must also have the capability to exclude segments of the beginning and ending of the burst so that the average power level of a defined central region can be measured. The power meter sensor must have a minimum video bandwidth of at least 300 kHz. The sample rate of the power meter must be sufficiently high that a minimum of 300 samples are taken across the central 85% of the pulse.

Power meters using diode detectors are sampling detectors. The meter should be configured to respond as an RMS detector.

As the GSM pulse level approaches the trigger level, spurious triggering may result. Due to this, the minimum dynamic range requirement from [Appendix D.2](#) is referenced from the trigger level rather than the noise floor. This is in order to reduce the number of spurious triggers caused by the nulls reaching the trigger level. Provided this requirement is met, pulses unable to meet the width criteria above after several retries may use the maximum signal level rather than the average of the center 85%. Similarly, the value of the trigger level may be substituted for signal levels below the trigger level that are unable to cause the analyzer to trigger. These allowances are made since these values will be in deep nulls of the pattern and have an insignificant effect on the TRP.

Refer to the following figures for examples of acceptable and unacceptable GSM pulses, as well as typical behavior as the signal approaches the trigger level. Note that as expected, the noise level increases as the signal approaches the noise floor. However, it should also be noted that the use of average pulse power as opposed to peak power reduces the uncertainty of the result due to the noise by approximately the square root of the number of points averaged. This is because the noise is a random error effect and the averaging process reduces the uncertainty, effectively lowering the noise floor.

FIGURE D-3 SAMPLE GSM POWER ENVELOPE WITH ACCEPTABLE RESOLUTION

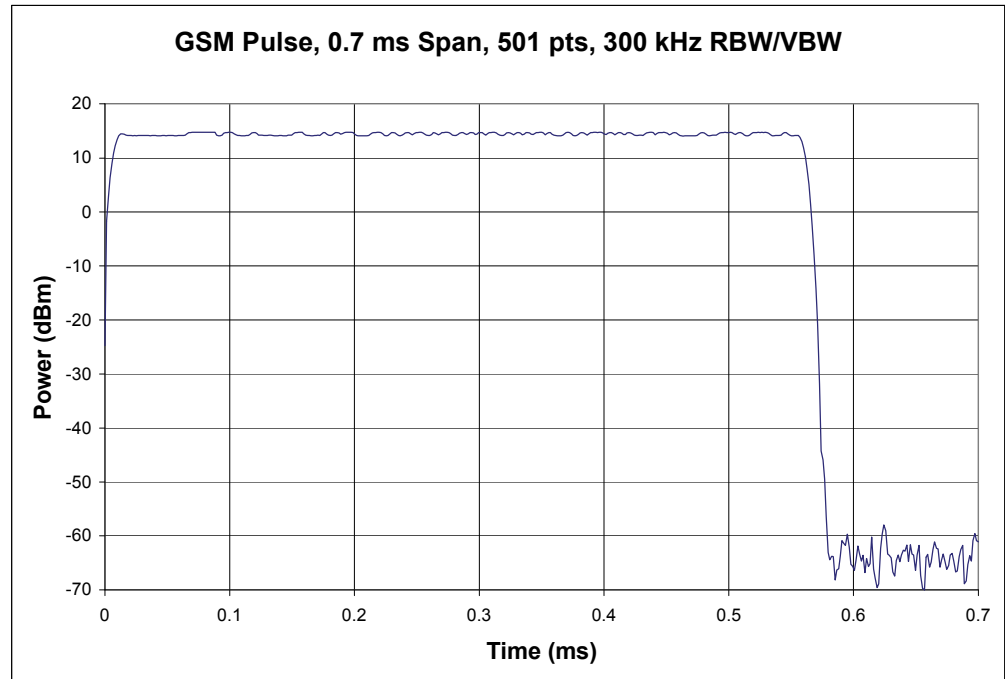

FIGURE D-4 SAMPLE GSM POWER ENVELOPE WITH INSUFFICIENT RESOLUTION

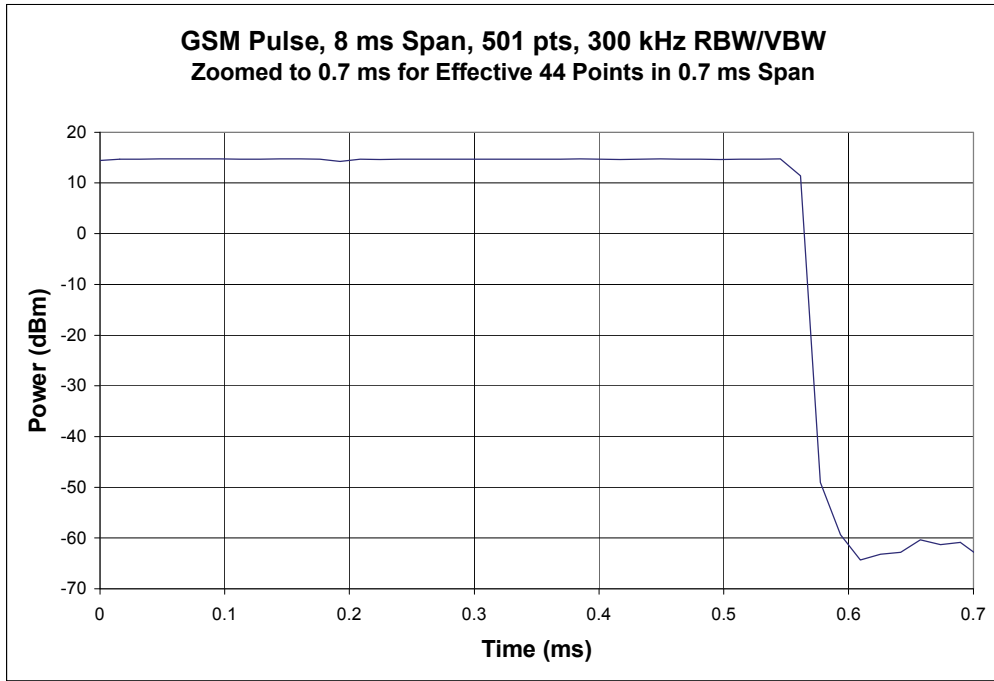
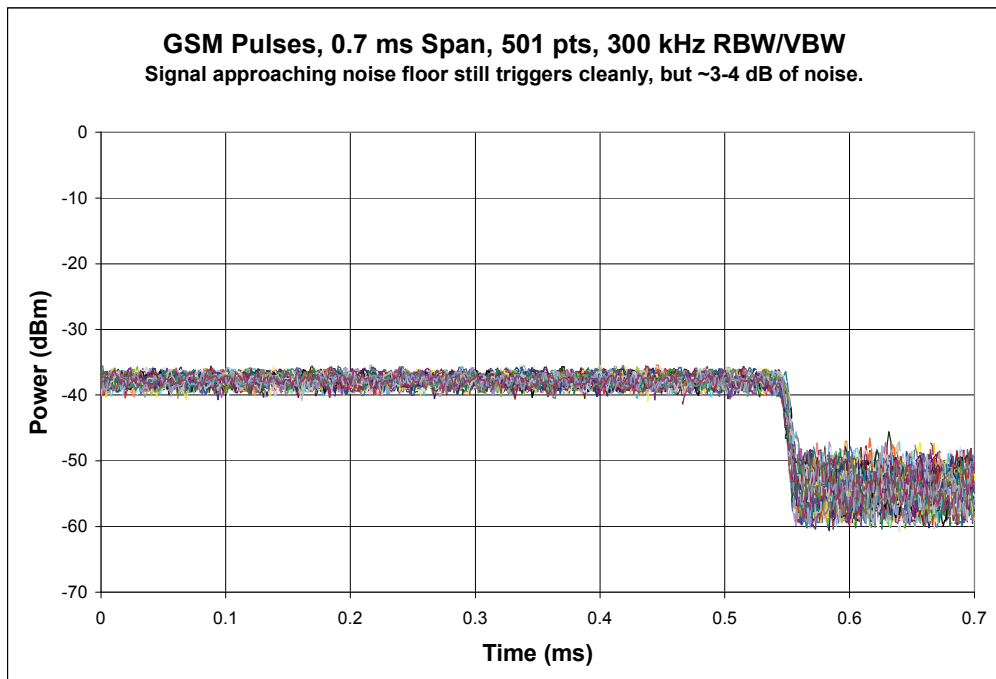

FIGURE D-5 SAMPLE GSM PULSES SHOWING INCREASE IN NOISE AS SIGNAL APPROACHES TRIGGER LEVEL



D.5 EGPRS/EDGE (8PSK Modulation)

EGPRS (EDGE) Packet Switched modes use a non-constant envelope modulation (8-PSK) modulation known as 8-Phase Shift Keying (8-PSK) that encodes three bits per symbol. The signal is slotted into 8 timeslots of approximately 0.577 ms with 148 symbols per slot. The non-constant modulation envelope of the 8-PSK pulse has almost 20 dB variation peak-to-null, and causes the average power of each frame to vary significantly based on the content of the frame, necessitating the average of multiple frames in order to obtain a stable average power reading. Some GMSK pulses are randomly interspersed between the 8-PSK pulses and must be detected separately and removed from the measurement. The treatment of the 8-PSK pulses is similar to that for GSM.

For the purposes of characterizing antenna performance, the minimum required power measurement is given by the linear average of a minimum of 1100 samples (corresponding to approximately 5 samples per symbol) across the central 85% of at least 20 valid 8-PSK bursts. This is typically accomplished using the RMS detector of a spectrum analyzer with a sample resolution of 450 ns or better. Averaging the power of 20 frames should reduce the resulting random uncertainty of a single data point to below ± 0.1 dB. Averaging 50 frames should reduce the random uncertainty below ± 0.05 dB. If the sample resolution is not high enough to meet the above criteria, or if only a sample detector is available, the number of frames averaged may be increased proportionally until the required number of individual samples is measured using either the RMS or sample detectors. In no case shall the sample rate be less than the symbol rate (270,833 symbols/s). For multi-slot EGPRS signals, the linear average of the center 85% of all active timeslots in one cycle should be used. A valid burst is defined as one having a width of 0.577 ms $\pm 10\%$. The spectrum analyzer must be set for zero-span using video or burst triggering with resolution and video bandwidths of 300 kHz. The trigger level should be set as close to the noise floor as possible without generating spurious triggers (typically 5-10 dB above the noise). For single timeslot measurements of a single pulse, the sweep time should be set such that the pulse takes up the majority of the available analyzer window. A setting of 0.6 ms is recommended. For multi-slot measurements, the span can be set to just larger than the total number of timeslots to be measured. Ideally there should be at least 100 points per timeslot to ensure that the center 85% of each timeslot can be easily determined.

Due to the depth of nulls seen in 8-PSK pulses, the minimum dynamic range requirement from [Appendix D.2](#) is increased by 20 dB and referenced from the trigger level rather than the noise floor. This is in order to reduce the number of spurious triggers caused by the nulls reaching the trigger level. Provided this requirement is met, pulses unable to meet the width criteria above after several retries may use the maximum signal level rather than the average of the center 85%. Similarly, the value of the trigger level may be substituted for signal levels below the trigger level that are unable to cause the analyzer to trigger. These allowances are made since these values will be in deep nulls of the pattern and have an insignificant effect on the TRP.

If a power meter is used, it must be capable of triggering from and measuring burst modulated signals with complex modulation formats. It must also have the capability to exclude segments of the beginning and ending of the burst so that the average power level of a defined central region can be measured. The power meter sensor must have a minimum video bandwidth of at least 300 kHz. The sample rate of the power meter must be sufficiently high that a minimum of 300 samples are taken across the central 85% of the pulse.

Power meters using diode detectors are sampling detectors. The meter should be configured to respond as an RMS detector.

Refer to the following figures for examples of acceptable and unacceptable 8-PSK pulses, as well as typical behavior as the signal approaches the trigger level. Note that as expected, the noise level increases as the signal approaches the noise floor. However, it should also be noted that the use of

average pulse power as opposed to peak power reduces the uncertainty of the result due to the noise by approximately the square root of the number of points averaged. This is because the noise is a random error effect and the averaging process reduces the uncertainty, effectively lowering the noise floor.

FIGURE D-6 SAMPLE 8-PSK POWER ENVELOPE WITH ACCEPTABLE RESOLUTION

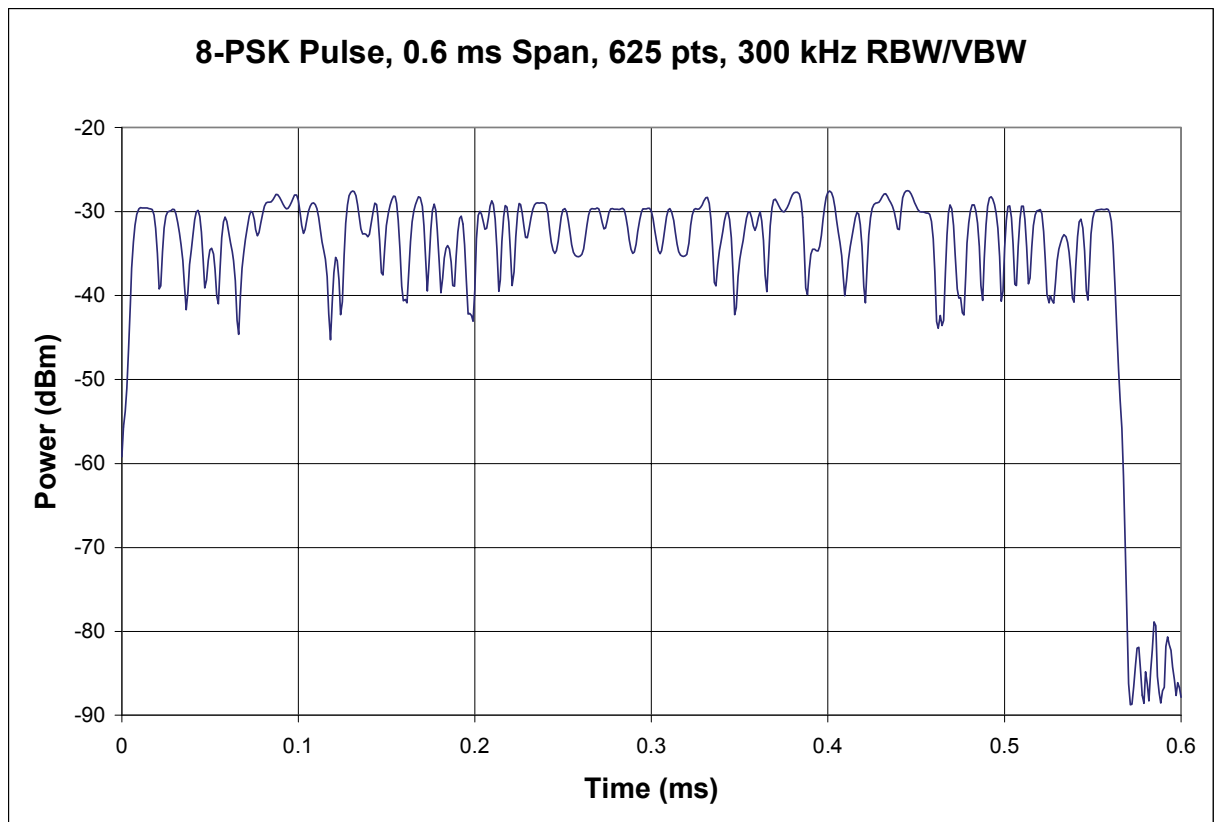

FIGURE D-7 MULTIPLE 8-PSK PULSES WITH RANDOM DATA CONTENT

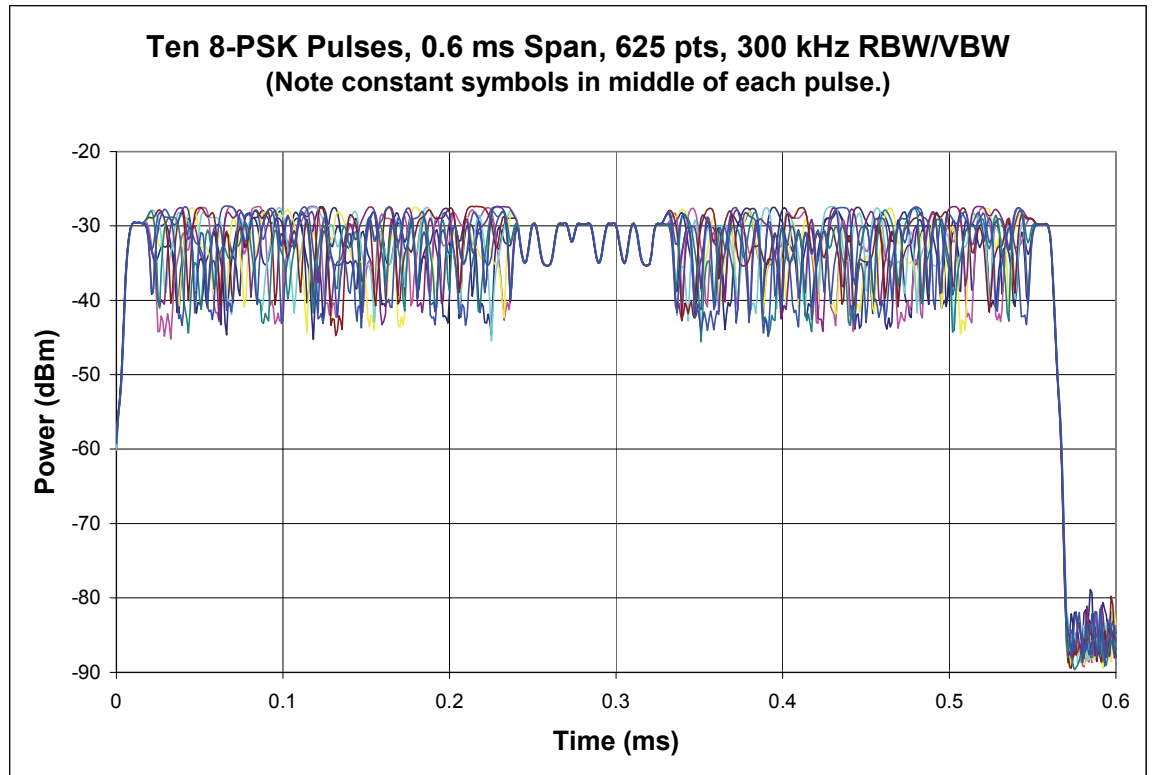

FIGURE D-8 EXAMPLE OF GMSK BURSTS MIXED IN WITH 8-PSK DATA

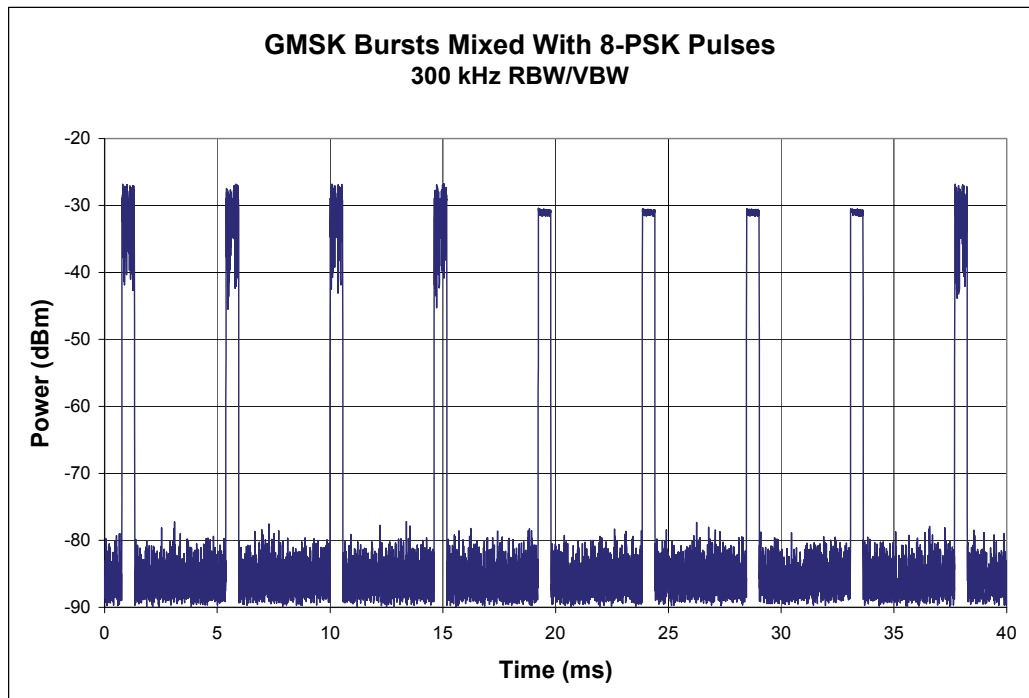

FIGURE D-9 SAMPLE 8-PSK PULSES SHOWING MIS-TRIGGERING AND INCREASE IN NOISE AT LOW LEVELS

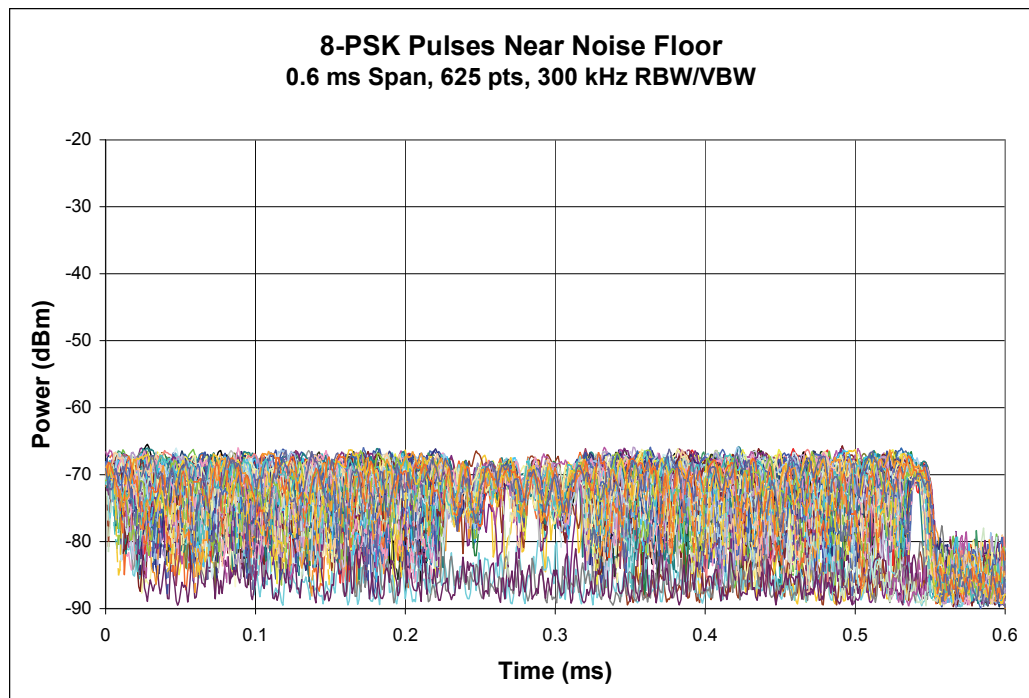

FIGURE D-10 SAMPLE MULTISLOT 8-PSK PULSES

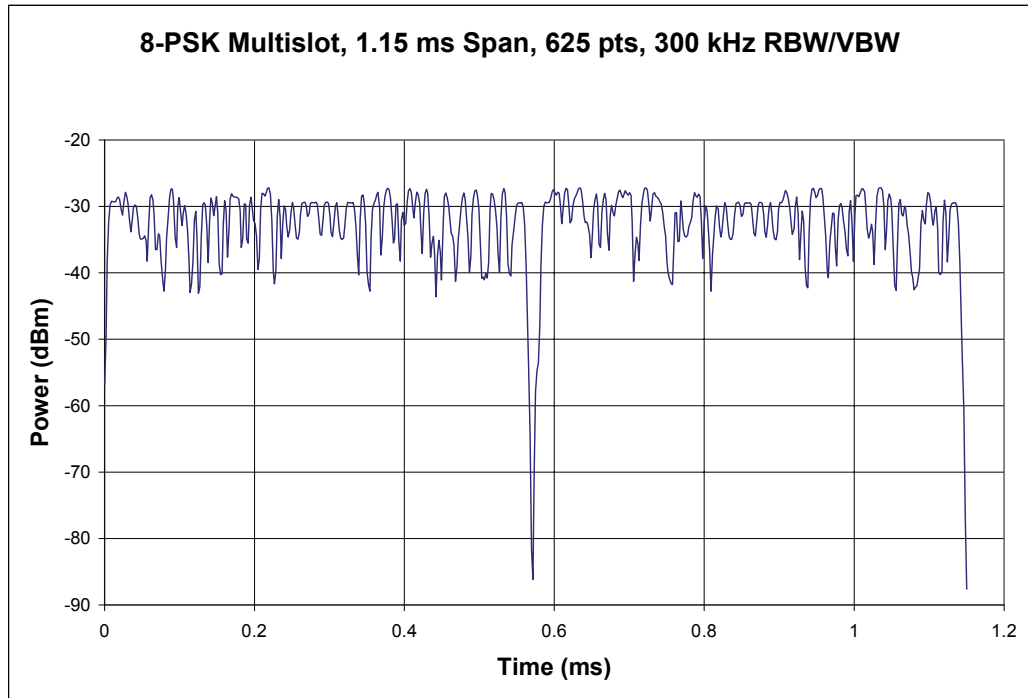

FIGURE D-11 BAD 8-PSK MULTISLOT TRACE RESULTING FROM GMSK BURST

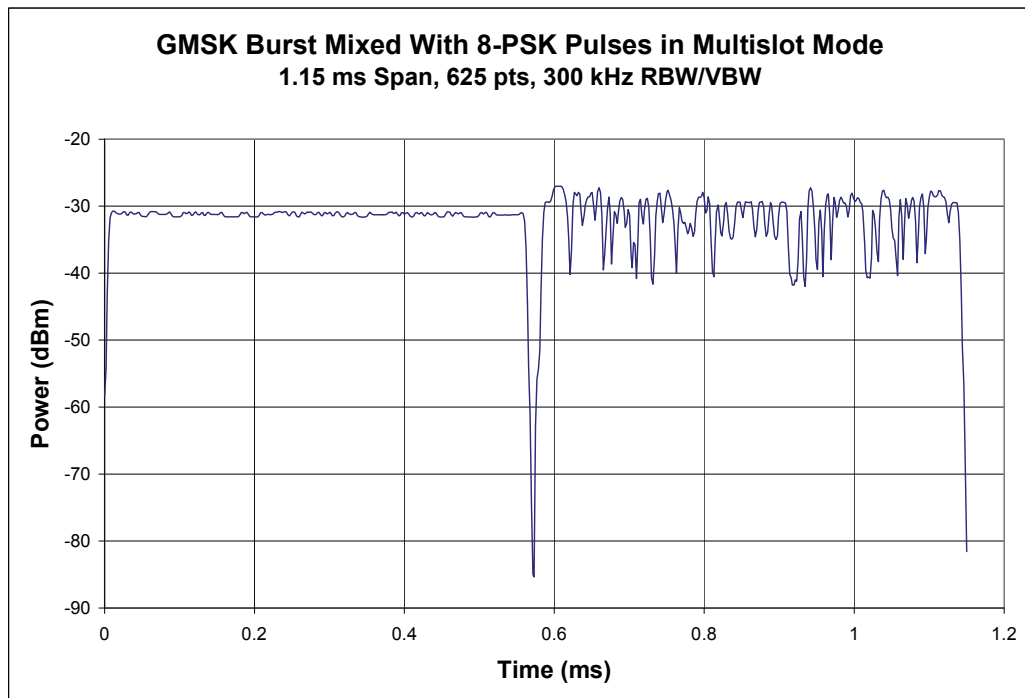
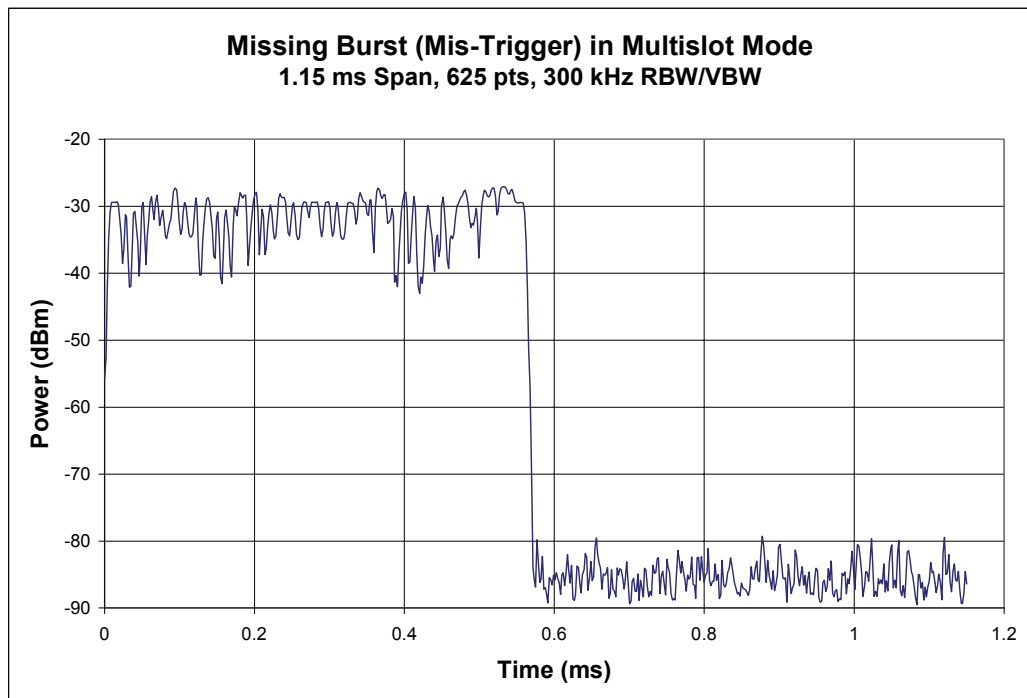

FIGURE D-12 BAD 8-PSK MULTISLOT TRACE RESULTING FROM MIS-TRIGGERING



D.6 AMPS

This section was removed for V3.1.

D.7 CDMA

CDMA uses a digital spread spectrum technology for communication. The base station manages power control dynamically by sending binary “up” or “down” signals to maintain the received power at a desired range. Maximum output power is set by sending the “up” bit signal constantly. After a few milliseconds, the device will be at maximum power.

In order to cover the range of the spread spectrum it is necessary to use a wide bandwidth on the front end of the receiver. However, the digital envelope will cause the peak detector to read high (Figure D-13), so it's necessary to use either an RMS or sample detector to get an accurate reading. In a typical spectrum analyzer, the sample detector records one sample from the analog to digital converter (ADC) at each point on the trace. Each trace point represents an instantaneous picture (sample) of the signal level at that point in time. The linear power average of this data provides an acceptable measurement of the average power in the spread spectrum signal. However, the stability of this result is dependent on the number of points measured. The standard deviation of a CDMA sample sweep is typically over 2.5 dB, resulting in an additional measurement uncertainty between 0.25 to 0.5 dB for a 401-point sample trace. By averaging multiple traces, or using more points per trace, it is possible to reduce this uncertainty. The use of an RMS detector over a sufficient time frame provides a lower noise sweep, since the RMS

detector performs the linear power average at each point on the trace for the period of time available to measure that point. Increasing the sweep time allows the RMS detector to average more samples together for each point on the trace.

For the purposes of characterizing mobile transmit power, it is required to determine the average power of the CDMA envelope for a minimum dwell time of 100 ms. For a complete spherical pattern, where over 350 individual points are measured to determine the average performance (TRP) it is considered acceptable to reduce the individual point dwell time to 20 ms. Assuming the EUT is stable and the test equipment operates as expected, this will introduce a negligible additional uncertainty to the measurement. However, in the event of a conflict, the 100 ms dwell time shall be considered the reference.

The spectrum analyzer shall be set for zero-span in free-run mode with resolution bandwidth of 3 MHz and a video bandwidth of 10 MHz (3 MHz if 10 MHz VBW is unsupported). Using an RMS detector, the sweep time shall be set to at least 100 ms for single point tests and at least 20 ms for complete pattern tests. When using a sample detector, this time period may be broken up into several smaller sweeps, if desired, to increase the accuracy of the sample average, but the total time of all sweeps shall be at least 100 ms for single point tests and at least 20 ms for complete pattern tests. The received signal must be stable for the entire trace in order to record a valid result. A stable trace is defined as all points within ± 0.5 dB of the median value. For the sample detector, the running average of 20% of the total number of points must remain within ± 0.5 dB of the median value of the running average. Alternately, the integrated channel power method described in the next section (WCDMA) may be used, with a channel bandwidth of 1.25 MHz.

If a power meter is used, it shall be capable of measuring the average power of modulated signals with complex modulation formats. The power meter sensor must have a minimum video bandwidth of at least 1.5 MHz. The power meter triggering shall be set to free-run and the sampling time set to 100 ms or greater for single point tests and at least 20 ms for complete pattern tests. The received signal must be stable for the entire trace in order to record a valid result. A stable trace is defined as all points within ± 0.5 dB of the median value. Power meters using diode detectors are sampling detectors, and the comments pertinent to sampling detectors in the above paragraph apply to these detectors.

Note: *The maximum signal level of a CDMA EUT often varies by several tenths of a dB over the period of several seconds. For the purposes of a TRP test, this variation averages out over the period of the 242 data points used for the TRP measurement. However, when measured for a single EIRP data point, such as for the purpose of performing one of the alternate measurement methods, the uncertainty of a single data point is likely to be significantly larger than that for the entire TRP measurement. To reduce this particular contribution, it is recommended that multiple sweeps be taken and averaged to determine a more stable power reading.*

Refer to the following figures for examples of CDMA power envelopes resulting from using different detectors and an example of the running average used when the sample detector is used.

FIGURE D-13 COMPARISON OF CDMA POWER ENVELOPE USING PEAK, RMS, AND SAMPLE DETECTORS

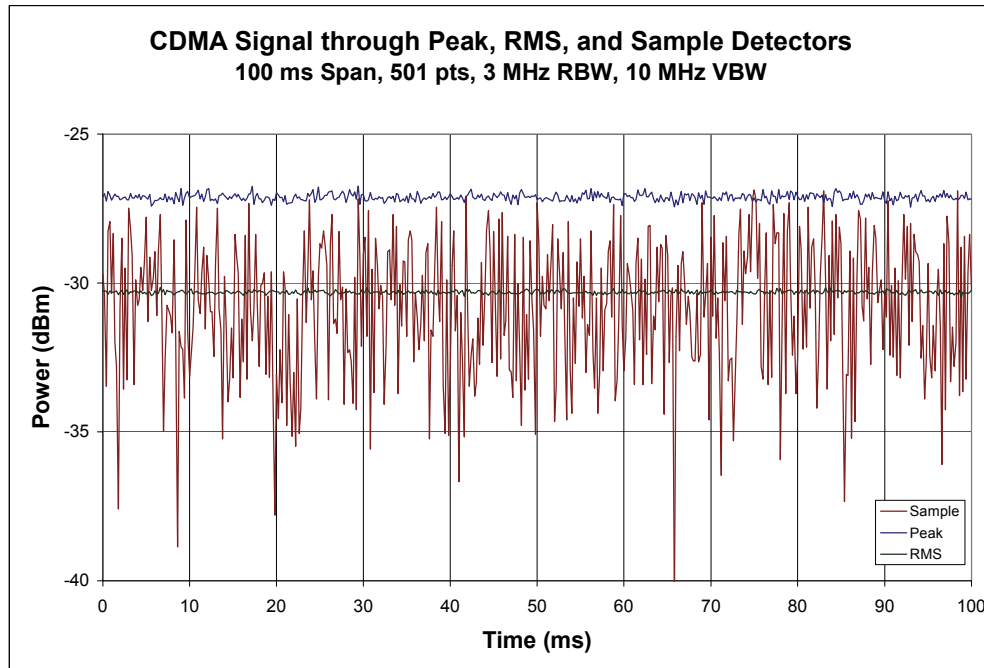

FIGURE D-14 EXAMPLE OF RUNNING AVERAGE USED TO QUALIFY SAMPLE DETECTOR SWEEP

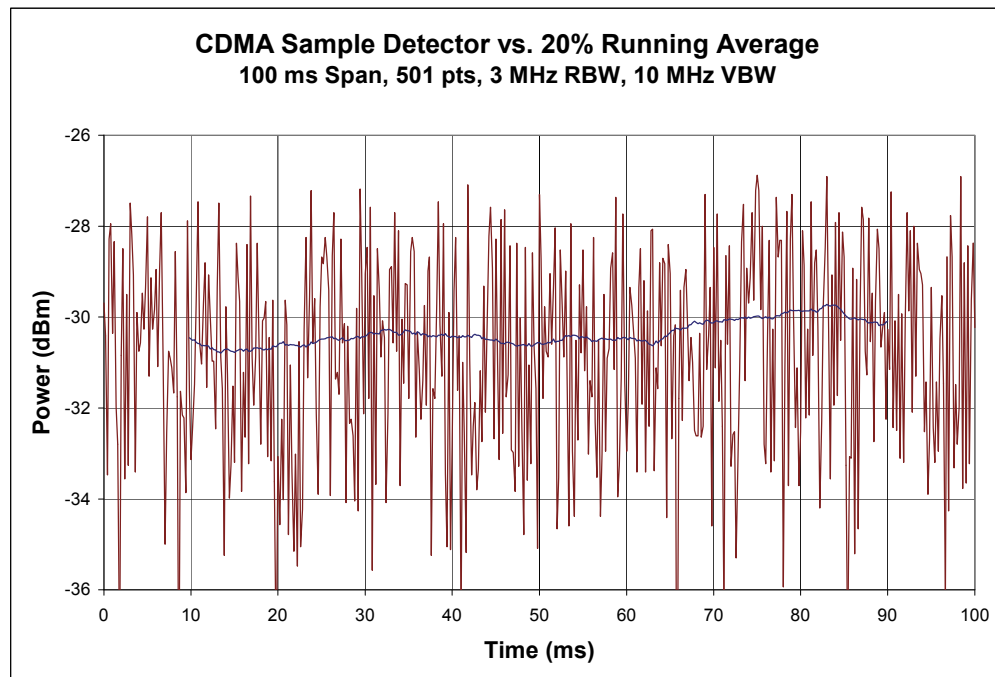
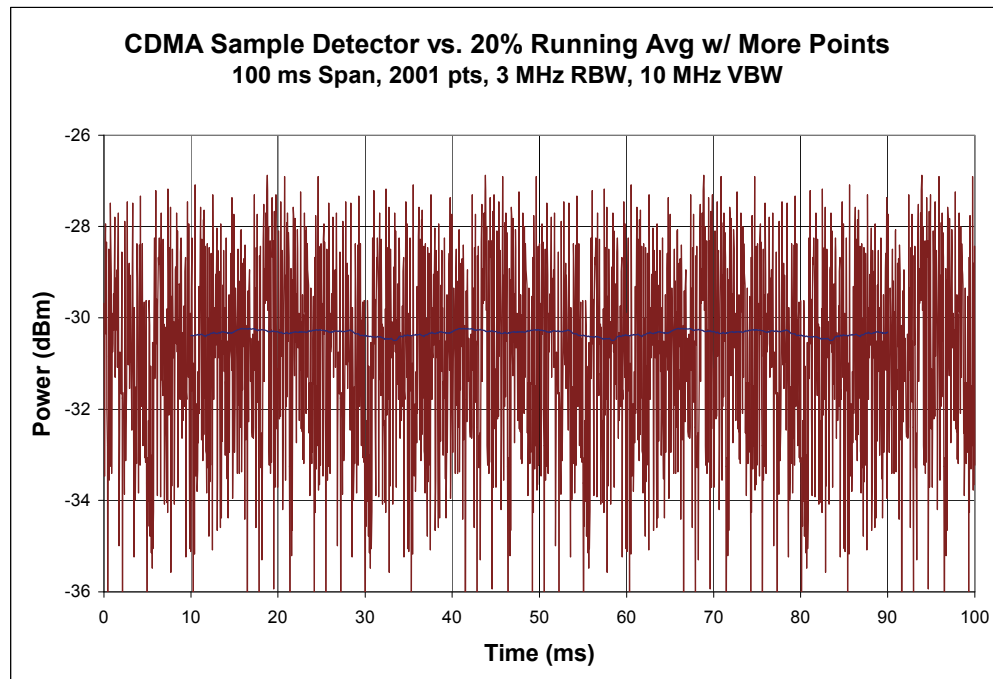

FIGURE D-15 EXAMPLE OF RUNNING AVERAGE WHEN MORE POINTS ARE USED



D.8 WCDMA (UMTS)

Wideband CDMA uses a digital spread spectrum technology for communication. The communication channel is similar to CDMA, but with a wider bandwidth. As with CDMA, the base station can manage power control dynamically by sending binary “up” or “down” signals to maintain the received power at a desired range. Maximum output power is set by sending the “up” bit signal constantly. After a few milliseconds, the device will be at maximum power.

Since many spectrum analyzers are limited to only 3 MHz RBW, a zero-span power measurement is usually not appropriate for this technology. For accurate measurement of wideband CDMA channels using spectrum analyzers with limited bandwidth, an integrated channel power (ICP) measurement must be used to determine the total power in a channel. This is done by scanning the entire channel bandwidth using a narrow resolution bandwidth and then summing the power spectral density (scaled trace data points) across the measured bandwidth. A resolution bandwidth (RBW) from 0.5 to 3.0% of the total bandwidth is typically used to ensure that the band is sampled with sufficient resolution. The following equation is then used to compute the resulting channel power:

EQUATION D.3

$$P = \frac{CBW}{NBW} \times \frac{1}{N} \sum_{i=1}^N P_i$$

where P_i is the power of each data point in the trace, represented in linear units, CBW is the bandwidth of the channel, NBW is the noise bandwidth represented by the measurement of each data point in the trace, N is the number of points in the sweep, and P is the resulting channel power, again in linear units. Some spectrum analyzers may have this function built in as an optional measurement mode, but it's simple to perform this measurement without needing that additional functionality. The noise bandwidth is roughly equivalent to the resolution bandwidth setting of the spectrum analyzer, however, depending on the shape of the RBW filter implementation in the analyzer, there can be as much as half a dB of deviation between the RBW setting and the NBW needed for the calculation. To address this, we can re-write Equation D.3 to be:

EQUATION D.4

$$P = \frac{CBW}{NBW} \times \frac{1}{N} \sum_{i=1}^N P_i = CF_{\frac{RBW}{NBW}} \frac{CBW}{RBW} \times \frac{1}{N} \sum_{i=1}^N P_i$$

where RBW is the resolution bandwidth used to sweep across the channel, and $CF_{\frac{RBW}{NBW}}$ is a correction factor to correct for the difference between the RBW and NBW. Spectrum analyzer manufacturers embed this correction factor in their internal ICP algorithms, but it's not normally published in a data sheet. See Appendix D.8.1 for direction on how to determine this correction factor directly for any given instrument.

For the purposes of characterizing mobile transmit power, it is required to determine the integrated channel power of the WCDMA channel for a minimum sweep time of 100 ms. For a complete spherical pattern, where over 350 individual points are measured to determine the average performance (TRP) it is considered acceptable to reduce the individual point dwell time to 20 ms. Assuming the EUT is stable and the test equipment operates as expected, this will introduce a negligible additional uncertainty to the measurement. However, in the event of a conflict, the 100 ms dwell time shall be considered the reference.

The spectrum analyzer shall be set for 5 MHz span in free-run mode with resolution bandwidth of 30 kHz and a video bandwidth set to the maximum supported by the spectrum analyzer (3 MHz is the minimum VBW allowed). Using an RMS detector with a sample resolution of 5 μ s or better, the sweep time shall be set to at least 100 ms for single point tests and at least 20 ms for complete pattern tests with a minimum of 401 data points per sweep. When using a sample detector, this time period may be broken up into several smaller sweeps, if desired, to increase the accuracy of the sample average, but the total time of all sweeps shall be at least 100 ms for single point tests and at least 20 ms for complete pattern tests. Whether using a sample detector or an RMS detector on a spectrum analyzer with a lower sampling rate, a total of at least 20,000 samples should be averaged across the band. The received signal must be stable for the entire trace in order to record a valid result. A stable trace is defined as a trace where no obvious signal drops to the noise floor are visible and where the running average over 10% of the span follows a smooth profile across the entire bandwidth. Ideally, the running average would remain within ± 1.0 dB of the median value over the center 60% of the trace. Note that this last criterion also implies that the trace should be flat across the entire channel. Some EUTs may have bad band filters or notches in the frequency response of their antennas that cause the trace to slope across the channel bandwidth. It is critical to ensure that any such phenomena are due to the EUT and not due to a bad measurement antenna or other problem with the measurement system.

If a spectrum analyzer supports sufficient resolution bandwidth to accurately measure the broadband WCDMA signal in a zero-span sweep, then it may be used as a broadband power measurement device rather than requiring integrated channel power measurements. For a Gaussian RBW filter shape, the RBW must be at least three times the channel bandwidth to obtain broadband power readings within 0.1 dB of the actual channel power. Newer spectrum analyzers often offer rectangular or flat-top filter options, which typically converge to the correct value when the RBW setting is something greater than 120% of the channel bandwidth. For the purposes of this test plan, broadband power measurements may be performed as described in the previous section for CDMA, using a Gaussian RBW of at least 20 MHz, or a flat top RBW filter of at least 8 MHz, with VBW set to the maximum supported by the spectrum analyzer.

If a power meter is used, it shall be capable of measuring the average power of modulated signals with complex modulation formats. The power meter sensor shall have a minimum video bandwidth of 10 MHz. The power meter triggering shall be set to free-run and the sampling time set to 100 ms or greater for single point tests and at least 20 ms for complete pattern tests. The received signal must be stable for the entire trace in order to record a valid result. A stable trace is defined as all points within ± 0.5 dB of the median value. Power meters using diode detectors are sampling detectors, and the comments pertinent to sampling detectors in the preceding paragraphs apply to these detectors.

Refer to the following figures for examples of WCDMA frequency response traces using RMS and sample detectors and the corresponding running average, as well as an example of a bad sweep.

FIGURE D-16 EXAMPLE OF VALID FREQUENCY RESPONSE TRACE USING RMS DETECTOR

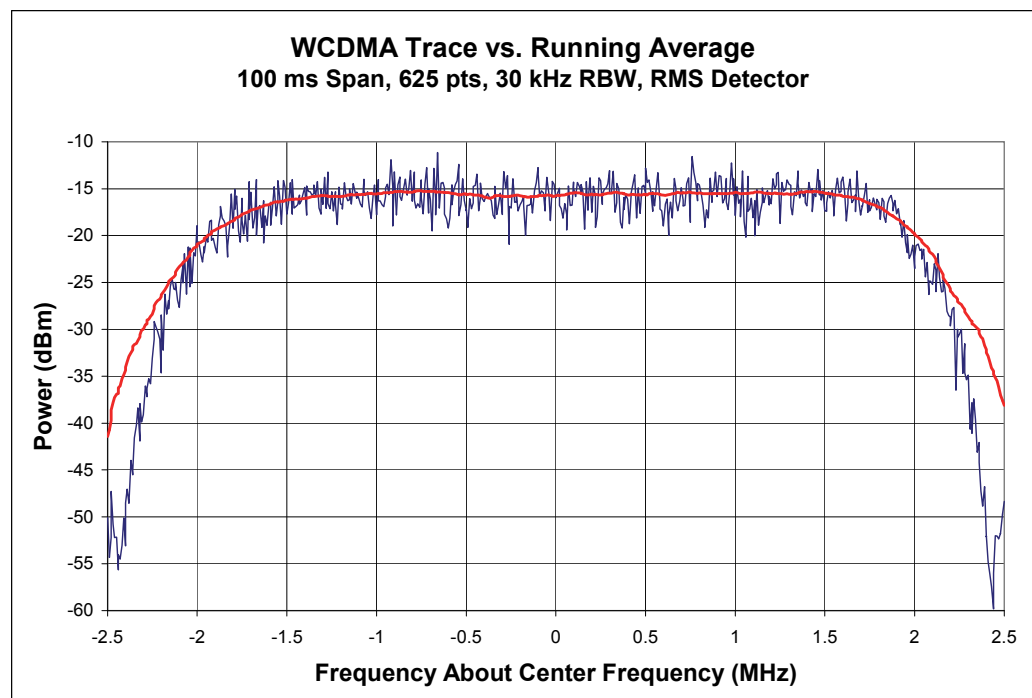

FIGURE D-17 EXAMPLE OF VALID FREQUENCY RESPONSE TRACE USING SAMPLE

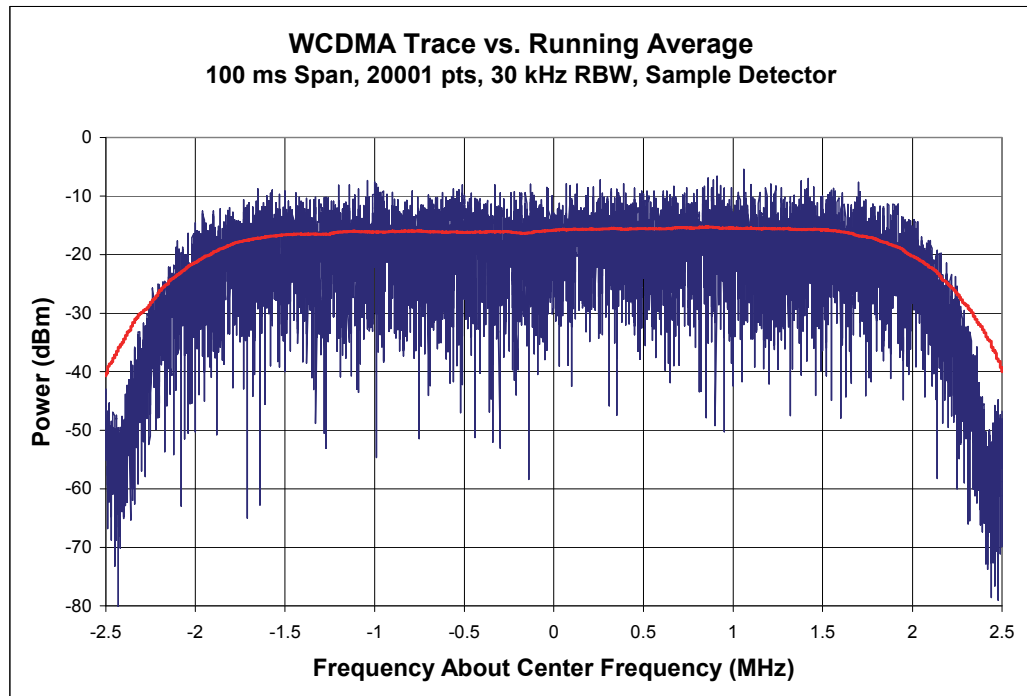
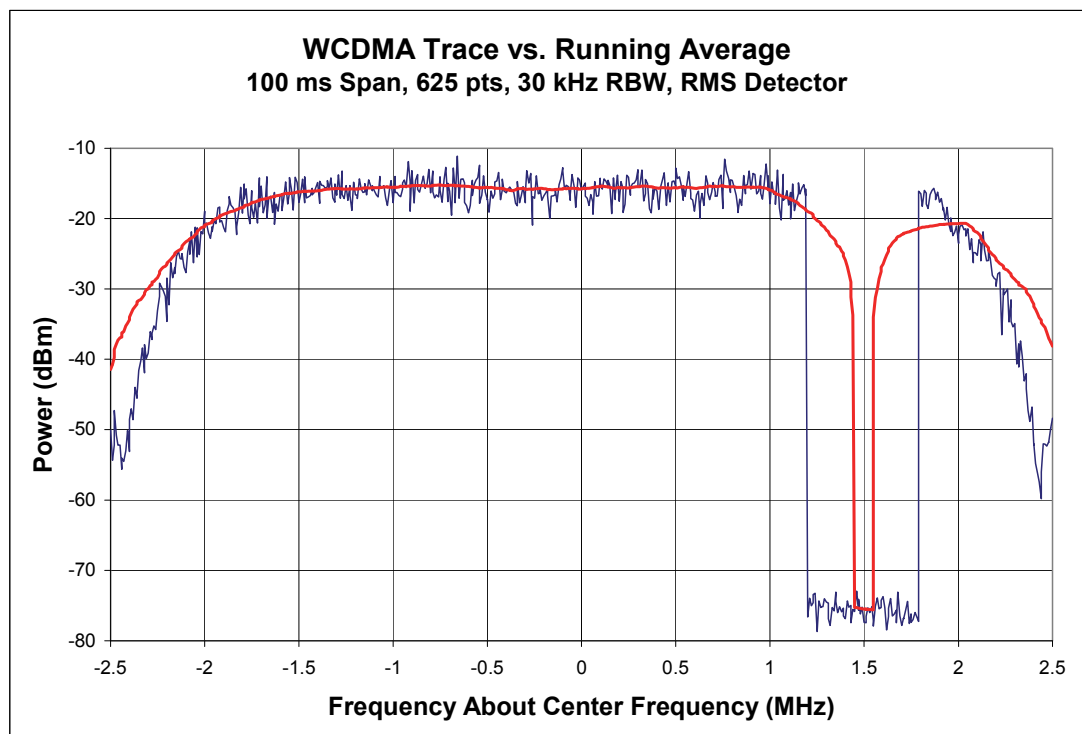

FIGURE D-18 EXAMPLE OF A SIGNAL DROP-OUT DURING AN RMS SWEEP



D.8.1 Determining the RBW/NBW Correction Factor

The integrated channel power formula is simply a weighted sum of the power measured in narrow frequency “windows” defined by the bandwidth filter of the spectrum analyzer. The assumption is that each point reports the power measured through a rectangular filter with a width defined by the noise bandwidth (NBW) value. To be statistically valid and capture the entire channel behavior, there must be enough measurement points so that each NBW window for each point touch without any gaps. In reality, however, the number of points are normally chosen such that the NBW overlaps at each point, requiring a weighting factor to average this out. Each point should represent a frequency range given by the channel bandwidth, divided by the total number of points. Thus, the power from each point with a width of *NBW* must be scaled by the factor:

EQUATION D.5

$$\frac{CBW}{NBW} \times \frac{1}{N}$$

Figure D-19 illustrates this concept.

FIGURE D-19 ILLUSTRATION OF THE DIFFERENCE BETWEEN NOISE BANDWIDTH AND DATA POINT WIDTH IN THE INTEGRATED CHANNEL POWER FORMULA

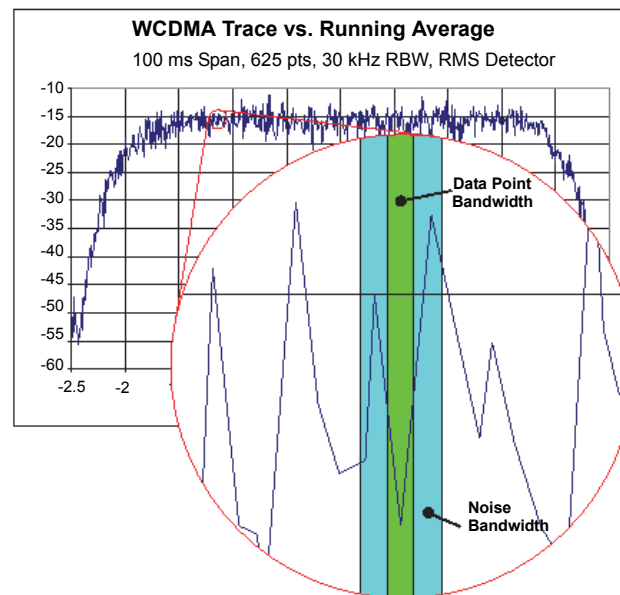

On a physical spectrum analyzer, the resolution bandwidth filter is not a perfect rectangular filter as the noise bandwidth is assumed to be. Rather, the typical RBW filter is a Gaussian filter, where the bandwidth is defined at the half power level of the Gaussian curve.

Figure D-20 illustrates the difference between an ideal Gaussian filter and a rectangular one, plotted on a linear power scale. While the tails of the Gaussian curve that extend outside the rectangular bandwidth are quite similar to the missing area near the peak of the filter, they do not cover the exact same amount

of area. The result is that, for a broadband signal, an ideal Gaussian filter will read 0.28 dB higher than a rectangular filter with equivalent half power bandwidth. Thus, to use a Gaussian RBW filter for the integrated channel power calculation, a correction factor must be applied to address the difference in power reading between the applied filter and the desired rectangular filter shape.

Unfortunately, the RBW filters of a spectrum analyzer are never perfect Gaussian filters. The correction factor between RBW and NBW can often be as much as 0.5 dB. Therefore, to obtain a suitable correction factor for use in [Equation D.4](#), it is necessary to determine the difference for the given spectrum analyzer directly. Newer spectrum analyzers may also offer the use of a rectangular or flat top filter shape instead of Gaussian. While this will normally reduce the required correction factor significantly, these filters are also never perfectly rectangular and thus still require some level of correction factor.

FIGURE D-20 COMPARISON OF A GAUSSIAN SHAPED RBW FILTER TO A RECTANGULAR NBW WITH THE SAME FREQUENCY BANDWIDTH

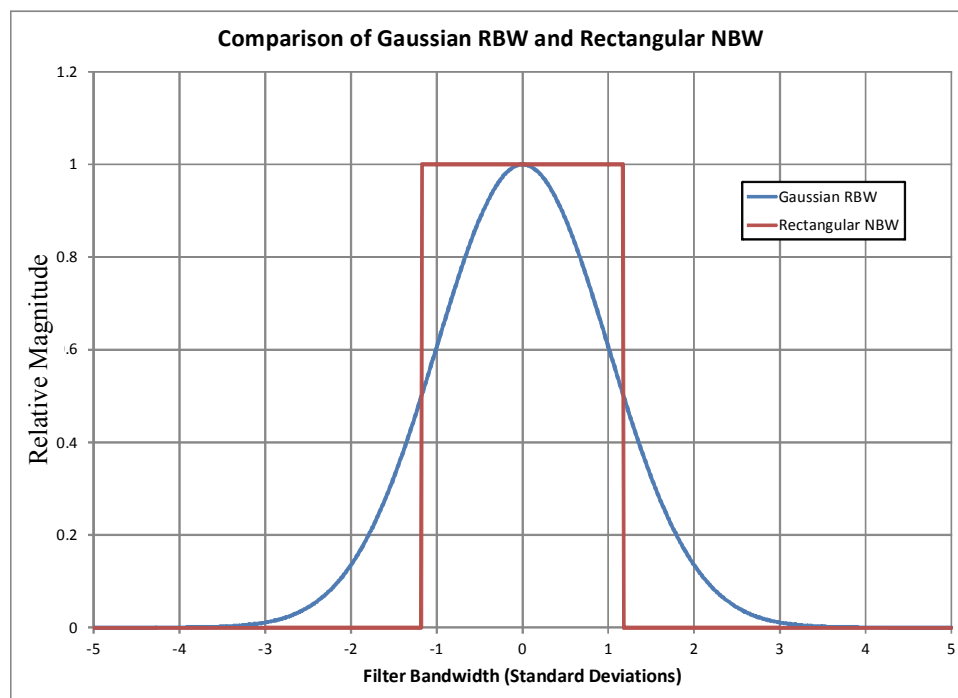
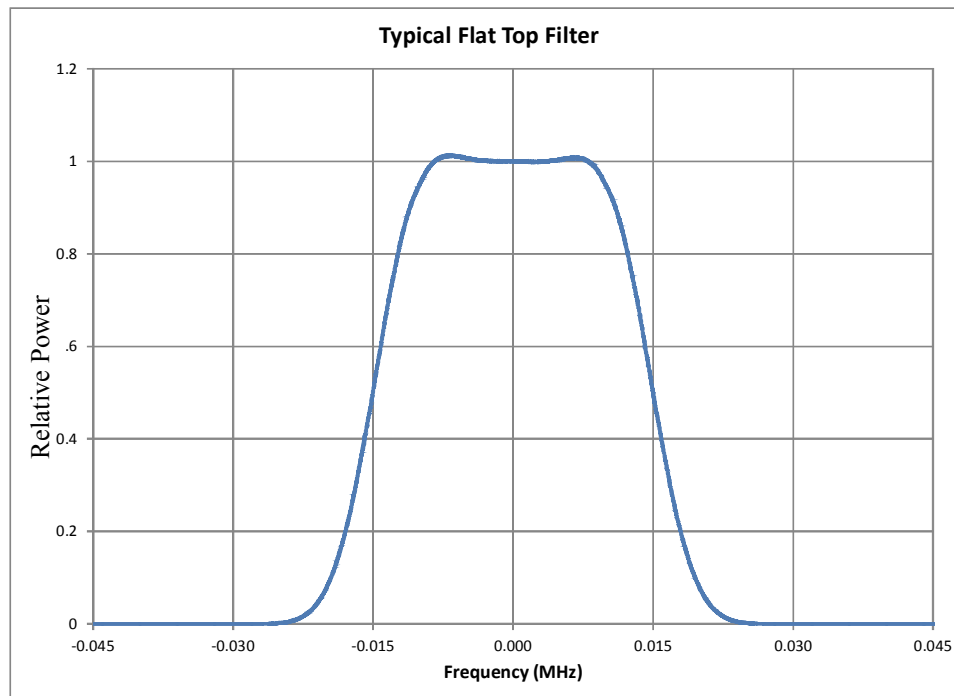

FIGURE D-21 EXAMPLE OF A FLAT TOP FILTER WITH 30 KHZ RBW



The following procedure may be used to determine the $CF_{RBW/NBW}$ value for use in Equation D.4.

1. Connect the output of a stable CW signal generator to the input of the spectrum analyzer to be evaluated. A 10 MHz reference connection is recommended to ensure that the two instruments are phase and frequency locked.
2. Set the center frequency for both units to 1 GHz (the choice of center frequency is somewhat arbitrary but should be in the range of normal operation of the spectrum analyzer for the target tests.)
3. Set the signal generator level to be approximately 10 dB below the reference level (top of the display window) of the spectrum analyzer.
4. Set the RBW to 30 kHz (or whatever RBW is to be evaluated).
5. Set the VBW to maximum.
6. Set the frequency span to 200 kHz (at least six times the RBW setting)
7. Select the RMS detector.
8. Set the number of sweep points to at least 1001, or the maximum allowed by the spectrum analyzer, but no more than 10,001.
9. Set the sweep time to one second.
10. Take one sweep and record the resulting trace. The shape of the RBW filter should be clearly visible centered in the trace.
11. Convert the trace from dBm to linear power units:

EQUATION D.6

$$P_{Linear} = 10^{P_{dB}/10}$$

12. Normalize the trace by dividing all points by the value at the center frequency. **Note:** *If a 10 MHz reference clock is not used, the center of the RBW filter may not appear in the exact center of the trace. For a Gaussian filter, using the maximum point in the trace is usually sufficient. However, for a rectangular/flat top filter where the filter can actually increase to either side of the center frequency, determination of the actual center of the filter is critical.*
13. Sum up the normalized linear trace values. **Note:** *This sum is impacted by the noise floor of the analyzer. This calculation assumes the peak is at least 40 dB above the noise floor and the span is not significantly larger than the visible bandwidth, such that the residual terms from the noise floor are negligible in the sum. To determine if there is a detectable impact from the noise, points near the noise floor may be set to zero and the resulting sum compared to the original.*
14. Determine the frequency step size of the trace by dividing the frequency span by the number of trace points minus one.
15. The correction factor is then given by:

EQUATION D.7

$$\begin{aligned} CF_{\frac{RBW}{NBW}} &= \frac{RBW}{f_{StepSize}} \times \frac{1}{Sum} \\ &= \frac{RBW}{F_{Span}} \times \frac{N-1}{\sum_{i=1}^N P_{Norm i}} \end{aligned}$$

where RBW is the selected resolution bandwidth, $f_{StepSize}$ is the frequency step size of the trace, Sum is the sum of the normalized linear trace values, F_{Span} is the frequency span of the trace, N is the number of points in the trace, and $P_{Norm i}$ are the individual normalized linear power trace points.

16. The correction factor may be converted to dB to allow it to be added directly to a resulting ICP result in dBm, where the RBW is used in place of NBW.

EQUATION D.8

$$CF_{dB} = 10 \times \log_{10} \left(CF_{\frac{RBW}{NBW}} \right)$$

D.9 LTE

LTE uses SC-FDMA to produce a digital spread spectrum where specific sub-channels may be used or unused depending on the configuration information provided by the eNodeB base station. Thus, the occupied bandwidth is configurable by the number of specified resource blocks (RBs) independent of the actual channel bandwidth, allowing multiple UEs to share one channel. Each resource block is 180 kHz

wide (200 kHz including guard intervals). The current TRP requirements specify sub-channel bandwidths of 12 RBs or 2.4 MHz for 10 MHz channels, 8 RBs or 1.6 MHz for 5 MHz channels, including a suitable guard band. While there are a number of different power control options for LTE, the test plan expects maximum power to be produced by sending the “up” command constantly. After a few hundred milliseconds, the device will be at maximum power.

LTE supports two frame structure types to enable both FDD and TDD modes of operation. Both types of frame are 10 ms in duration and consist of 10 subframes of 1 ms duration (see TS 36.211). In TDD mode, the frame can be divided into two half frames, with one special subframe per frame or half frame to facilitate downlink to uplink switching. A number of subframe and special subframe configurations are supported. The uplink period of the special subframe cannot be used for user plane data (PUSCH). Thus, under the default subframe configuration specified in TS 36.508, the UE will be transmitting 2 ms bursts every 5 ms to transport user plane data in PUSCH.

For the purposes of characterizing antenna performance, the integrated channel power may be determined using the technique described in [Appendix D.8](#) for WCDMA, or using a broadband power sweep as described in [Appendix D.7](#) for CDMA, with the following modifications. For integrated channel power, a channel bandwidth of 2.4 MHz shall be used (assuming 12 RBs allocated), centered on the occupied bandwidth defined by the resource block allocation. A stable trace should be flat to within ± 1.0 dB of the midpoint value for a 10% running average across the center 70% of the trace. For broadband power mode, the spectrum analyzer shall be set to at least the appropriate minimum RBW specified in [Table D-1](#), centered on the occupied bandwidth defined by the resource block allocation, with VBW set to maximum. A stable trace is defined as all points within ± 0.5 dB of the midpoint value. In either case, the required frequency offsets specified in [Table D-1](#) may be determined generally as $(RB_{Start} + (RB_{Allocation} - Total\ RBs) / 2) * 0.18\ MHz$.

TABLE D-1 BROADBAND POWER MODE MEASUREMENT REQUIREMENTS

Channel BW (MHz)	RB Allocation	Subchannel BW (inc. guard band) (MHz) ¹	Minimum RBW (MHz)	RB start	Frequency Offset (MHz)
5	8	1.6	4	0	-1.53
				8	-0.09
				17	+1.53
10	12	2.4	8	0	-3.42
				19	0.0
				38	+3.42
20	18	3.6	8 ²	0	-7.38
				41	0.0
				82	+7.38

Note 1: The Subchannel BW, including guard band, may be reconsidered in future versions as scaling guard band requirements with number of RBs may not be appropriate.

Note 2: The minimum RBW specified assumes that the resolution bandwidth filter is a flat-top filter. If a flat-top filter is not used, the minimum RBW shall be increased to meet the requirements in [Appendix D.8](#).

If a power meter is used, it shall be capable of measuring the average power of modulated signals with complex modulation formats. The power meter sensor shall have a minimum video bandwidth of 10 MHz. The power meter triggering shall be set to free-run and the sampling time set to 100 ms or greater for single point tests and at least 20 ms for complete pattern tests. The received signal must be stable for the entire trace in order to record a valid result. A stable trace is defined as all points within ± 0.5 dB of the median value. Power meters using diode detectors are sampling detectors, and the comments pertinent to sampling detectors in the preceding paragraphs apply to these detectors.

In addition, for the case of measurements with the TDD frame structure, the broadband power measurement is the linear average of the center 95% of the 2ms burst and the measurement shall be triggered in order to synchronize the measurement with the burst. If a power meter is used, it must be capable of triggering from and measuring the average power of multiple bursts of modulated signals with complex modulation formats.

Refer to the following figures for examples of LTE frequency response traces for various configurations.

FIGURE D-22 EXAMPLE OF VALID LTE FREQUENCY RESPONSE TRACE USING RMS DETECTOR.

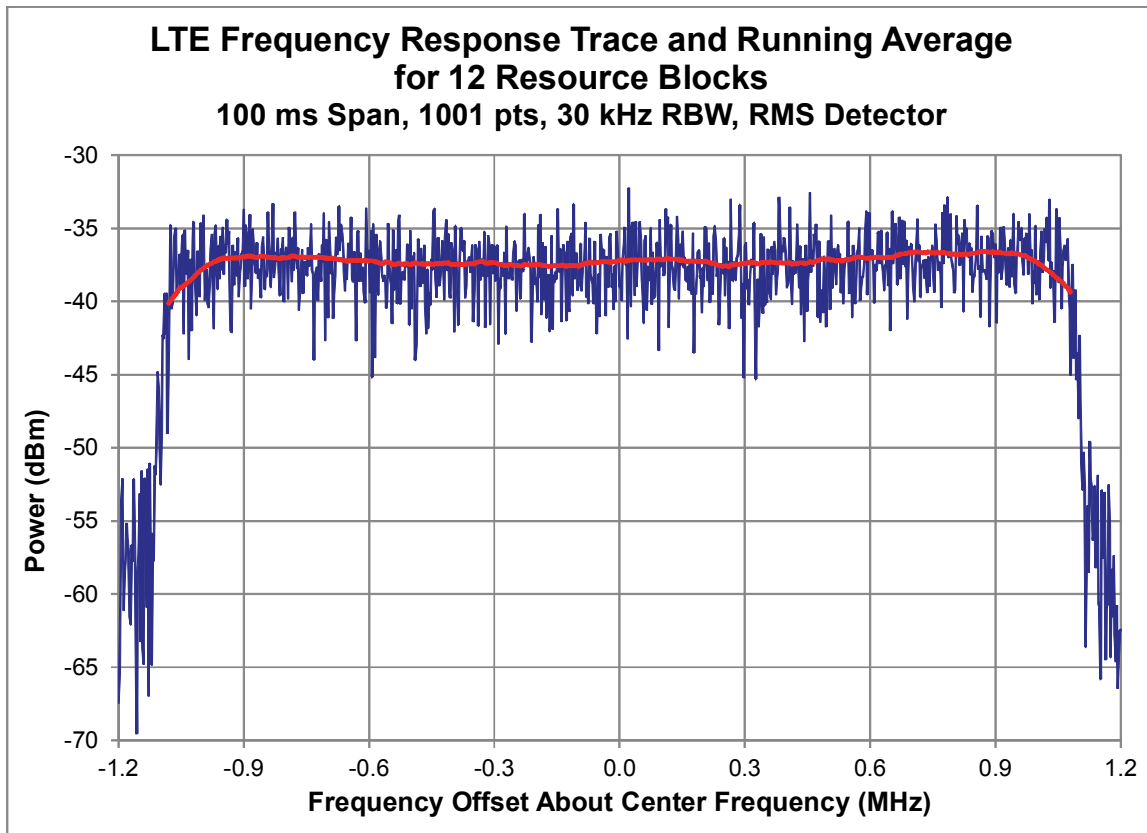
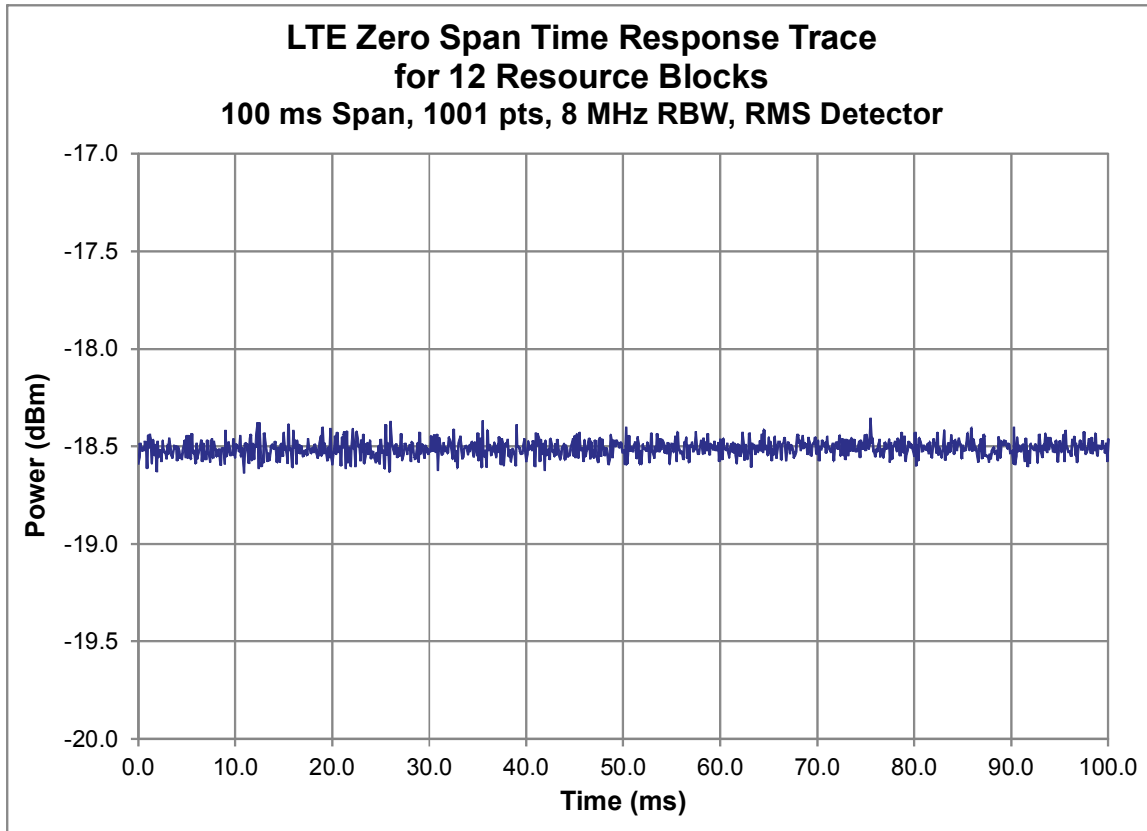

FIGURE D-23 EXAMPLE OF VALID LTE WIDEBAND TIME RESPONSE TRACE USING RMS DETECTOR



D.10 LTE Category M1

LTE Category M1 supports FDD, half-duplex FDD (HD-FDD), and TDD modes of operation. Devices that operate in FDD or TDD mode shall be tested using the spectrum analyzer broadband power mode or the power meter guidelines outlined in [Appendix D.9](#). The spectrum analyzer settings specified in [Table D-1](#) shall be replaced with the settings in [Table D-2](#) below.

TABLE D-2 LTE CATEGORY M1 BROADBAND POWER MODE MEASUREMENT REQUIREMENTS

Channel BW (MHz)	Power Class	RB Allocation	Subchannel BW (inc. guard band)(MHz) ¹	Minimum RBW (MHz)	RB Start	Frequency Offset (MHz)
5	3	1	0.2	3	0	-2.16
					13	0.18
					24	2.16
	5	3	0.6	3	0	-1.98
					13	0.36
					22	1.98
10	3	4	0.8	3	1	-3.96
					25	0.36
					45	3.96
	5	5	1.0	3	1	-3.87
					25	0.45
					44	3.87
20	3	6	1.2	4	2	-8.10
					50	0.54
					92	8.10
	5	6	1.2	4	2	-8.10
					50	0.54
					92	8.10

Note 1: The Subchannel BW, including guard band, may be reconsidered in future versions as scaling guard band requirements with number of RBs may not be appropriate.

In addition, for the case of measurements with HD-FDD, the broadband power measurement shall be the linear average of the center 95% of the 3ms burst and the measurement shall be triggered in order to synchronize the measurement with the burst. If a spectrum analyzer is used, the settings in [Table D-2](#) shall be used. If a power meter is used, it must be capable of triggering from and measuring the average power of multiple bursts of modulated signals with complex modulation formats.

D.11 LTE Category NB1 (NB-IoT)

LTE Category NB1 supports half-duplex FDD (HD-FDD) mode of operation with a maximum channel bandwidth of 180kHz (200kHz including guard intervals). The occupied bandwidth is configurable by the transmission bandwidth configuration (Ntone), allowing multiple UEs to share one channel.

The current TRP requirements specify a transmission bandwidth configuration Ntone = 1 with a 15kHz sub-carrier spacing (i.e. sub-channel bandwidth is 15kHz) allocated at the lower or higher edge of the channel bandwidth, so there is a very small difference (<100kHz) between the test channel (i.e., FUL) and the actual center frequency for the subcarrier allocation. Therefore, power measurements shall be done on FUL.

For the purposes of characterizing antenna performance, the broadband power mode described in [Appendix D.7](#) for CDMA may be used, with the following modifications. The spectrum analyzer shall be set to a RBW of 300kHz and VBW of 1MHz. The broadband power measurement shall be the linear average of the center 95% of the 8ms burst and the measurement shall be triggered in order to synchronize the measurement with the NPUSCH burst.

If a power meter is used, it must be capable of triggering from and measuring the average power of multiple bursts of modulated signals with complex modulation formats.

D.12 NR FR1 (Informative)

NR uses CP-OFDM in the Uplink and Downlink as well as DFT-s-OFDM in the Uplink. The occupied bandwidth is configurable by the number of specified resource blocks (RBs) independent of the actual channel bandwidth, allowing multiple UEs to share one channel. NR FR1 supports scalable sub-carrier spacing (SCS) of 15 kHz, 30 kHz, and 60 kHz as well as wider channel bandwidths (CBWs) compared to LTE. The relationship between SCS, CBW, and maximum transmission bandwidth configuration NRB is outlined in TS 38.101-1, specifically Section 5.3.2. While there are a number of different power control options for NR, the test plan expects maximum power to be produced by sending the “up” command constantly. After a few hundred milliseconds, the device will be at maximum power.

NR supports two frame structure types to enable both FDD and TDD modes of operation. Both types of frame are 10 ms in duration and consist of 10 subframes of 1 ms duration.

For the purposes of characterizing antenna performance, the integrated channel power may be determined using the technique described in [Appendix D.8](#) for WCDMA, or using a broadband power sweep as described in [Appendix D.7](#) for CDMA, with the same modifications as for LTE with respect to the subchannel BWs as described in [Appendix D.9](#). The required frequency offsets specified in [Table D-3](#) may be determined generally as $(RB_{Start} + (RB_{Allocation} - Total\ RBs) / 2) * 12 * SCS$.

TABLE D-3 BROADBAND POWER MODE MEASUREMENT REQUIREMENTS FOR NR FR1

CBW [MHz]	SCS [kHz]	N_{RB}	RB Allocation	Subchannel BW (incl. guard band) (MHz)	Minimum RBW (MHz)	RB Start	Frequency Offset [MHz]
5	15	25	12	2.645	6	6	-0.09
10	15	52	25	5.125	11	12	-0.27
15	15	79	36	7.245	15	18	-0.63
20	15	106	50	9.905	20	25	-0.54
40	15	216	108	20.545	42	54	0
60	30	162	81	30.810	62	40	-0.18
100	30	273	135	50.290	101	67	-0.72

Power meters using diode detectors are sampling detectors. The comments pertinent to sampling detectors in the preceding paragraphs apply to these detectors, e.g., a total of at least 20,000 samples should be averaged across the band.

In addition, for the case of measurements with the TDD frame structure, the broadband power measurement is the linear average of the center 95% of the 2ms burst and the measurement shall be

triggered to synchronize the measurement with the burst. If a power meter is used, it must be capable of triggering from and measuring the average power of multiple bursts of modulated signals with complex modulation formats.

Appendix E Total Isotropic Sensitivity and Total Radiated Power Derivations (Informative)

This appendix describes a way of reducing complete spherical patterns of receive-sensitivity or effective isotropic radiated power data to single figures of merit, and to give some meaningful examples of this process. The basic principle applied is to compare the EUT's performance to that of a transceiver with a perfect (100% efficient) antenna.

E.1 Total Isotropic Sensitivity

FIGURE E-1 TIS

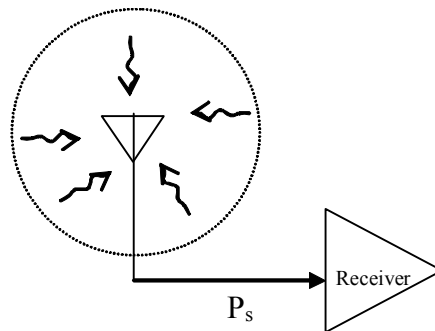

Definitions

This subsection utilizes Yeh's derivation of average received power in the mobile environment as described in Jakes' *Microwave Mobile Communications* [5]. While some equations from that derivation are reproduced here for clarity, the reader is referred to that source for its complete development.

Assume a hypothetical scattered environment which provides equal mean incident powers [6] in both of the orthogonal components E_θ and E_ϕ , and a uniform distribution of angle of incidence (across all θ, ϕ) for both polarizations. Now assume the mean incident powers for both polarizations are simultaneously adjusted (while held equal to one another) so that the average power available to the EUT's receiver from the EUT's antenna when immersed in this environment⁶ is equal to the power required for the receiver to operate at its threshold of sensitivity (e.g., a specified bit error rate). If the EUT were now replaced with an ideal isotropic antenna which has equal gain in each linear polarization E_θ and E_ϕ in every direction, the mean power available from the ideal isotropic antenna immersed in this same scattered environment is defined as the **Total Isotropic Sensitivity**⁷, **TIS**, expressed in Watts.

Define the Effective Isotropic Sensitivities, EIS, as follows:

6. Most correctly, "immersed in the environment" means the EUT is moved randomly through the (assumed stationary) environment so as to accomplish this averaging of the incident power. In this section, "immersion" is used as shorthand for this hypothetical movement process.
7. This is a sensible definition because it compares the EUT's antenna/receiver system to a perfect, 100% efficient antenna that responds equally to either polarization.

$EIS_{\theta}(\theta, \phi)$ = Power available from an ideal isotropic, theta-polarized antenna generated by the theta-polarized plane wave incident from direction (θ, ϕ) which, when incident on the EUT, yields the threshold of sensitivity performance.

$EIS_{\phi}(\theta, \phi)$ = Power available from an ideal isotropic, phi-polarized antenna generated by a phi-polarized plane wave incident from direction (θ, ϕ) which, when incident on the EUT, yields the threshold of sensitivity performance.

EIS is the pattern quantity that is actually measured in the chamber during the EUT Measurement Part, by recording power required at each angle and polarization to achieve sensitivity, and is expressed in Watts. It is determined by including the same path-loss factor (as measured at the receive frequency instead of the transmit frequency) that is used in the chamber to yield EIRP for a transmitting antenna. Note that the EIS terms are defined with respect to a single-polarized ideal isotropic antenna, but the TIS is defined with respect to a dual-polarized ideal isotropic antenna. This is a convenience to make the path loss characterization procedure (i.e., the Range Reference Measurement) for receive measurements in the chamber correspond with the path loss characterization procedure done for EIRP. That is to say, the same type of path loss terms, recorded at the appropriate receive frequency, that are generated in the Range Reference Measurement to yield EIRP patterns for a transmit test will yield EIS patterns for a receive test as defined here (based on single-polarized isotropic references). TIS is based on a dual-polarized isotropic comparison, because real-world EUTs and propagation are dual-polarized. Proper choice of integration kernels will be seen to reconcile this apparent difference.

In general, it will be seen that

EQUATION E.1

$$EIS_x(\theta, \phi) = \frac{P_s}{G_{x,EUT}(\theta, \phi)},$$

where P_s is the radiated sensitivity of the EUT's receiver and $G_{x,EUT}(\theta, \phi)$ is the relative isotropic gain (in polarization x) of the EUT's antenna (in this case, including mismatch and ohmic losses) in the direction (θ, ϕ) . Radiated sensitivity corresponds to the minimum signal power at the radio receiver's input (antenna's output) required to meet the airlink's minimum performance criterion (typically expressed in terms of bit, block or frame error rate). The radiated sensitivity can differ from that found in a conducted test due to interaction factors such as self-desensitization and other non-linear behaviors.

Calculation of Received Power

Following Yeh's derivation of average received power, a right-hand spherical coordinate system (θ, ϕ, r) is utilized, where: \vec{a}_{θ} and \vec{a}_{ϕ} are orthogonal unit vectors associated with θ and ϕ . In the general case, the average power received by an antenna in a scattered environment is (equation 3.1-22 of Jakes):

$$P_{rec} = \oint [P_1 G_{\theta}(\Omega) P_{\theta}(\Omega) + P_2 G_{\phi}(\Omega) P_{\phi}(\Omega)] d\Omega,$$

where Ω is the coordinate point on a spherical surface given by (θ, ϕ) , and $d\Omega$ is the differential element of solid angle, $\sin(\theta)d\phi d\theta$. This is equivalently written as:

EQUATION E.2

$$P_{rec} = \oint [P_1 G_\theta(\theta, \phi) P_\theta(\theta, \phi) + P_2 G_\phi(\theta, \phi) P_\phi(\theta, \phi)] \sin(\theta) d\phi d\theta$$

$G_\theta(\theta, \phi)$ and $G_\phi(\theta, \phi)$ are the power gain patterns for the θ and ϕ polarizations, respectively, of the antenna, and $P_\theta(\theta, \phi)$ and $P_\phi(\theta, \phi)$ are the angular density functions of incoming plane waves having θ and ϕ polarizations, respectively, for the environment. P_1 and P_2 are, respectively, the average powers that would be received by a θ - or ϕ -polarized ideal isotropic antenna in the scattered environment.

$P_\theta(\theta, \phi)$ are constants equal to $\frac{1}{4\pi}$ (yielding a uniform distribution of angle of incidence),

and P_1 is equal to P_2 . Specifically, P_1 and P_2 are equal to that particular value P_{TIS} which yields the condition of the EUT being at the specified threshold of sensitivity in the hypothetical scattered environment, or $P_1 = P_2 = P_{TIS}$.

For the case of the EUT under these conditions, the mean power delivered by its antenna to its receiver when immersed in this same scattered environment is, by definition, the receiver's sensitivity power, P_S , so that Equation E.2 becomes:

EQUATION E.3

$$P_S = \frac{P_{TIS}}{4\pi} \oint [G_{\theta,EUT}(\theta, \phi) + G_{\phi,EUT}(\theta, \phi)] \sin(\theta) d\phi d\theta,$$

for the EUT which has antenna gain patterns $G_{x,EUT}(\theta, \phi)$ and is immersed in the scattered environment.

The ideal isotropic dual-polarized antenna envisioned in the definition of TIS would have a total power gain in every direction of 1 (that is, 0 dBi). Therefore, its component gains in each polarization in every direction are 1/2 (that is, -3 dBi), $G_\theta(\theta, \phi) = G_\phi(\theta, \phi) = 1/2$. Hence, substituting into, the average received power for the dual-polarized isotropic antenna in the described environment, TIS, is seen to be:

EQUATION E.4

$$TIS = \oint \left[P_{TIS} \cdot \frac{1}{2} \cdot \frac{1}{4\pi} + P_{TIS} \cdot \frac{1}{2} \cdot \frac{1}{4\pi} \right] \sin(\theta) d\phi d\theta = \frac{P_{TIS}}{4\pi} \oint \sin(\theta) d\phi d\theta = P_{TIS}$$

Turning to the EIS definitions, for example that of $EIS_\theta(\theta, \phi)$, Equation E.1 can also be justified. The $EIS_\theta(\theta, \phi)$ measurement refers to an average received power with a single, θ -polarized plane wave incident on the EUT from a particular direction (θ, ϕ) . As shown by Taga, this particular case can also be treated using Equation E.2 by setting:

$$P_\theta(\theta, \phi) = \frac{[\delta(\theta - \theta_s) \delta(\phi - \phi_s)]}{\sin(\theta)} \quad \text{and} \quad P_\phi(\theta, \phi) = 0,$$

where $\delta(x)$ is the dirac delta function and (θ_s, ϕ_s) represents a particular direction for which the EIS is being evaluated. Substituting into Equation E.2 for the EIS case (and recalling that the received power in this case is defined to be the sensitivity power, P_S), we have:

$$P_S = \oint \left[P_{1,EIS} G_{\theta,EUT}(\theta, \phi) \frac{[\delta(\theta - \theta_s) \delta(\phi - \phi_s)]}{\sin(\theta)} + 0 \right] \sin(\theta) d\phi d\theta = P_{1,EIS} G_{\theta,EUT}(\theta_s, \phi_s),$$

where $P_{1,EIS}$ is just the mean incident power constant that yields the threshold of sensitivity for the EUT at the angle (θ_s, ϕ_s) .

For the θ -polarized ideal isotropic antenna envisioned in the definition of $EIS_\theta(\theta, \phi)$, its gain function is $G_\theta(\theta, \phi) = 1$ (that is, 0 dBi) and $G_\phi(\theta, \phi) = 0$. Similarly substituting these into Equation E.2 yields:

$$EIS_\theta(\theta_s, \phi_s) = \oint \left[P_{1,EIS} \cdot 1 \cdot \frac{[\delta(\theta - \theta_s)\delta(\phi - \phi_s)]}{\sin(\theta)} + 0 \right] \sin(\theta) d\phi d\theta = P_{1,EIS}$$

Combining these last two equations, we have:

$$P_S = EIS_\theta(\theta_s, \phi_s) G_{\theta,EUT}(\theta_s, \phi_s) \quad ,$$

for the particular evaluation point (θ_s, ϕ_s) , or more generally for the function at any angle,

$$P_S = EIS_\theta(\theta, \phi) G_{\theta,EUT}(\theta, \phi)$$

A similar development would yield the analogous expression for $EIS_\phi(\theta, \phi)$, and these two results lead directly to Equation E.1.

Hence, we can rearrange Equation E.1 so that:

$$G_{x,EUT}(\theta, \phi) = \frac{P_S}{EIS_x(\theta, \phi)}$$

Substituting into Equation E.3 yields:

$$P_S = \frac{P_{TIS}}{4\pi} \oint \left[\frac{P_S}{EIS_\theta(\theta, \phi)} + \frac{P_S}{EIS_\phi(\theta, \phi)} \right] \sin(\theta) d\phi d\theta$$

This can be rearranged to yield:

$$P_{TIS} = \frac{4\pi}{\oint \left[\frac{1}{EIS_\theta(\theta, \phi)} + \frac{1}{EIS_\phi(\theta, \phi)} \right] \sin(\theta) d\phi d\theta}$$

Substituting this into Equation E.4 yields:

EQUATION E.5

$$TIS = \frac{4\pi}{\oint \left[\frac{1}{EIS_\theta(\theta, \phi)} + \frac{1}{EIS_\phi(\theta, \phi)} \right] \sin(\theta) d\phi d\theta}$$

Results for a few Special Cases

Assume that the receiver, environment, and antenna are all at the same temperature, e.g., 290K.

Case 1: The EUT employs a 100% efficient, single-polarized, ideal isotropic radiator: For example, assume the EUT's antenna is an ideal, theta-polarized isotropic antenna. By definition, $EIS_{\theta}(\theta, \phi)$ is then P_s for every angle, and $EIS_{\phi}(\theta, \phi)$ is infinite at every angle.

Then Equation E.5 becomes:

$$TIS = \frac{4\pi}{\oint \left[\frac{1}{P_s} + \frac{1}{\infty} \right] \sin(\theta) d\phi d\theta} = \frac{4\pi}{\oint \left[\frac{1}{P_s} + 0 \right] \sin(\theta) d\phi d\theta} = \frac{P_s 4\pi}{\oint \sin(\theta) d\phi d\theta} = P_s$$

In other words, TIS of an EUT with a 100% efficient, ideal isotropic, single-polarized antenna is just the sensitivity power, P_s .

Case 2: The EUT employs a 100% efficient, dual-polarized, ideal isotropic radiator: $EIS_{\theta}(\theta, \phi)$ is then $2P_s$ for every angle, and $EIS_{\phi}(\theta, \phi)$ is also $2P_s$ at every angle. (Recall that the EIS is defined with respect to a single-polarized isotropic, and a dual-polarized isotropic antenna must have half the gain in each polarization of a corresponding single-polarized isotropic antenna.) Then Equation E.5 becomes:

$$TIS = \frac{4\pi}{\oint \left[\frac{1}{2P_s} + \frac{1}{2P_s} \right] \sin(\theta) d\phi d\theta} = \frac{P_s 4\pi}{\oint \sin(\theta) d\phi d\theta} = P_s$$

Again, an EUT with a 100% efficient, ideal isotropic antenna has a TIS that is equal to the conducted sensitivity of the receiver, P_s .

Case 3: The EUT employs a 50% efficient but otherwise ideal, single-polarized isotropic antenna. $EIS_{\theta}(\theta, \phi)$ is then $2P_s$ for every angle (the antenna is a 3 dB attenuator, degrading the receiver noise figure by 3 dB, so twice the power is required to get the same performance), and $EIS_{\phi}(\theta, \phi)$ is infinite at every angle. Thus, Equation E.5 becomes:

$$TIS = \frac{4\pi}{\oint \left[\frac{1}{2P_s} + \frac{1}{\infty} \right] \sin(\theta) d\phi d\theta} = \frac{4\pi}{\oint \left[\frac{1}{2P_s} + 0 \right] \sin(\theta) d\phi d\theta} = \frac{2P_s 4\pi}{\oint \sin(\theta) d\phi d\theta} = 2P_s$$

Therefore, an EUT with a 50% efficient antenna has a TIS equal to the conducted sensitivity degraded by 3 dB (i.e., twice as large).

This supports two general conclusions. First, the lower limit (best achievable value) for TIS is simply the conducted sensitivity of the EUT's receiver, P_s . This TIS is achieved with a perfectly matched, 100% efficient antenna. Second, the TIS of a real antenna will be the conducted sensitivity of its receiver degraded by the mismatch/efficiency loss of the antenna.

E.1.1 Total Isotropic Sensitivity Estimator Based on RSS-Based Methods

For the purposes of TIS, the "threshold of sensitivity performance" would be that point at which the wireless device just passes the sensitivity test; that is, EIS for a given angle/polarization is the minimum RF power level where the radiated sensitivity test still passes.

Because each EIS measurement can be very time-consuming, a complete spherical TIS measurement performed by repeating the sensitivity test to determine every EIS point on the sphere would require extensive test time. Hence the ability to accurately estimate the EIS pattern, and thus the resultant TIS, in a reduced timeframe is critical to minimize the overall test time required to certify a product. The basic approach is to make a minimum number (generally only one) of direct EIS measurements, and then to substitute other less-time-consuming means of capturing the pattern shape information needed to determine the entire EIS pattern. Since this process relies on the repeatability of a single-point EIS measurement, rather than the integrated result of many single-point EIS measurements, some increase in uncertainty will be incurred.

The basic approach is to directly measure EIS at a single angle/polarization, and then to provide the pattern information through the use of receive signal strength (RSS) measurements reported by the EUT (for some technologies like GPS this may be C/N_0 or some other indicator of the received signal strength), which is a quick measurement that can be performed at all the other angles of the sphere.

To accomplish this in a radiated test chamber, incident field on the EUT is raised by some practical amount (typically 20 dB or so) above the point where the EUT is operating at its threshold of sensitivity on its pattern peak, and then fixed there for the remainder of the pattern measurement process. Ideally this level is near the top of the linear portion of whatever RSS report the EUT can produce, but must not be above the maximum RSS value the EUT can report. At each angle/polarization, the RSS reported by the EUT is recorded as the pattern value for that angle/polarization.

In addition to the RSS pattern information, an RSS linearization curve is required to “calibrate” the data reported by the EUT. This creates a transfer standard between the EUT and the calibrated signal generator (base station simulator, satellite simulator, etc.) used to generate the downlink signal. Because the TIS is primarily determined by peaks in the RSS pattern, which tend to cover more surface area than nulls, the linearization is critical within at least the first 10 dB below the pattern peak. While ideally the linearization should be evaluated across the entire range of RSS values recorded in the pattern, for pattern nulls more than 10 dB below the peak, extrapolation may be used to determine the remaining linearization correction. Normally, the linearization should be determined in an over-the-air configuration for one polarization at the peak of the pattern, but conducted linearization curves may be used in certain circumstances provided additional uncertainty terms are applied to the result.

The linearization curve can be treated as a function of the output power of the signal generator such that the measured RSS is given by:

$$RSS_i = RSS(P_{SG_i})$$

Assuming that the RSS data is monotonic, an inverse function can be defined such that:

$$RSS_i = RSS^*(RSS_i)$$

so that:

$$P_{SG_i} = RSS^*(RSS_i)$$

The conversion from RSS to power may use linear interpolation or curve fitting as necessary to fill in between measured and reported RSS and power steps. The assumption for currently defined RSS based metrics is that linear interpolation is done in dB, not linear power units, although this could be different for other technologies. Note that in cases where interpolation between points may not be the best solution, best fit lines or curves could produce an RSS^* relationship that does not lie directly on the measured linearization data.

Once all of the measured RSS values in the pattern have been linearized, the pattern should be normalized by dividing each pattern value by the peak value in linear power units (equivalent to

subtracting the peak from the pattern in dB). The entire process can be represented by the following equation:

$$P(\theta, \phi, Polarization) = RSS^*(RSS(\theta, \phi, Polarization)) / RSS^*(RSS_{Peak}) ,$$

where RSS_{Peak} is the maximum RSS determined in the pattern (for GNSS this may be the maximum RSS determined in the upper hemisphere of the pattern). The result is a relative pattern with a peak value of 1.0 (0 dB) for any polarization.

A full EIS measurement is performed at the same peak position and polarization to determine a reference for the resultant estimated EIS pattern, which is then given by:

$$EIS(\theta, \phi, Polarization) = EIS_{ref} / P(\theta, \phi, Polarization)$$

where all terms are in linear power units. Alternately the EIS pattern can be determined by subtracting the relative pattern from the reference EIS value in dB. From this point, the previously defined integrals can be used to determine TIS and the various partial surface integrals required for a given technology.

This linearization and normalization method can be repeated to reduce the resultant measurement uncertainty by normalizing to multiple EIS reference values around the surface of the sphere and then averaging the resulting patterns. Through this process, the uncertainty associated with using a single EIS reference can be reduced by a factor of $1/\sqrt{N}$ where N is the number of EIS points used to determine the average EIS pattern.

E.2 Total Radiated Power

FIGURE E-2 TRP

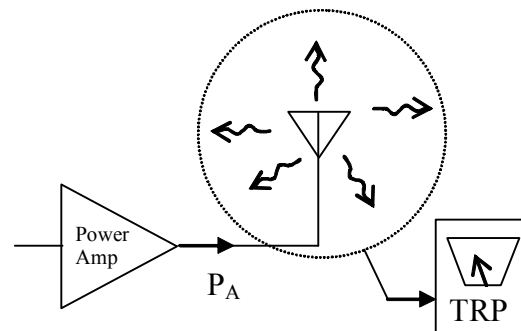

Definitions

P_A = Power delivered to the antenna (properly, the power available to the actual antenna load), in W

TRP = Total Radiated Power, the power that is actually radiated by the antenna, in W

The TRP is the sum of all power radiated by the antenna, regardless of direction or polarization. If the antenna were enclosed in a perfectly absorbing sphere, the TRP would be the power that would be absorbed by that sphere. TRP can be related to P_A in this fashion:

EQUATION E.6

$$TRP = P_A \cdot \text{eff}$$

Where

eff = Radiation efficiency of the antenna

The radiation efficiency, eff , is defined in most antenna textbooks [7] as the ratio of the power radiated by an antenna to the power delivered to the antenna. The power delivered to the antenna may differ from the output of the power amplifier into a 50 ohm load due not only to antenna mismatch, but also any non-linear interaction factors induced in the active circuitry.

Derivation of Total Radiated Power

The Total Radiated Power of a given antenna and source is (see, for example, Stutzman & Thiele, page 33, equation 1-131):

$$TRP = \oint U(\theta, \phi) d\Omega,$$

Where $U(\theta, \phi)$ = radiation intensity at each angle in Watts/steradian.

Expanding this integral,

$$TRP = \int_{\theta=0}^{\pi} \int_{\phi=0}^{2\pi} U(\theta, \phi) \sin(\theta) d\phi d\theta$$

It is seen that the $\sin(\theta)$ term results simply from the mathematical expansion of the differential element of solid angle, $d\Omega$.

$$d\Omega = \sin(\theta) d\phi d\theta.$$

The effective isotropic radiated power, EIRP, is defined as (Stutzman & Thiele, page 62, equations 1-226 and 1-227):

$$EiRP(\theta, \phi) = P_T G_T(\theta, \phi) = 4\pi U(\theta, \phi),$$

Where $P_T G_T$ is the product of the power delivered to the antenna and the antenna's power gain. (The equation cited in the reference is actually for the specific case of peak EIRP at the angle of maximum gain, but the reasoning used in the reference produces the above equation for the more general EIRP vs. angle function.)

Then we have:

$$U(\theta, \phi) = \frac{EiRP(\theta, \phi)}{4\pi},$$

And the integral for TRP becomes:

EQUATION E.7

$$TRP = \frac{1}{4\pi} \int_{\theta=0}^{\pi} \int_{\phi=0}^{2\pi} EiRP(\theta, \phi) \sin(\theta) d\phi d\theta$$

Thus, if the complete spherical pattern of the EIRP of the EUT is integrated with the $\sin(\theta)$ weighing as described in this equation, the result will be the total power the EUT is radiating. It should be noted here that this integration would be modified to yield the same total radiated power if the pattern measurement is expressed in terms of ERP (effective radiated power referenced to a half-wave dipole) rather than EIRP. Specifically, ERP is numerically 2.14 dB less than EIRP:

$$ERP(\theta, \phi) \cong \frac{EiRP(\theta, \phi)}{1.64}$$

so that:

$$TRP \cong \frac{1.64}{4\pi} \int_{\theta=0}^{\pi} \int_{\phi=0}^{2\pi} ERP(\theta, \phi) \sin(\theta) d\phi d\theta$$

It must be emphasized that, whether the pattern data itself is taken in the form of ERP or EIRP, use of the appropriate integration will yield numerically the same TRP (as well it should-the EUT is radiating the same power in either case).

In practice, the total EIRP will likely be measured at each sample point by measuring its two orthogonally polarized components, $EiRP_{\theta}(\theta, \phi)$ and $EiRP_{\phi}(\theta, \phi)$. To accommodate this measurement practicality, we can split the radiation intensity at each angle into two contributions, one from each polarization (power in independent components simply adds):

$U_{\theta}(q, f)$ = Radiation intensity due to theta component of E-field

$U_{\phi}(q, f)$ = Radiation intensity due to phi component of E-field

Then Equation E.7 can be re-derived as:

EQUATION E.8

$$TRP = \frac{1}{4\pi} \int_{\theta=0}^{\pi} \int_{\phi=0}^{2\pi} (EiRP_{\theta}(\theta, \phi) + EiRP_{\phi}(\theta, \phi)) \sin(\theta) d\phi d\theta$$

E.3 Conversion of Integrals to Summations of Discretely Sampled Pattern Data

It can be seen that both the TIS and TRP expressions [Equation E.5 and Equation E.8] involve integrals of the form.

EQUATION E.9

$$I = \frac{1}{4\pi} \int_{\theta=0}^{\pi} \int_{\phi=0}^{2\pi} K(\theta, \phi) \sin(\theta) d\phi d\theta$$

where K is some function of theta and phi. This subsection treats the manner in which equations of this form are to be approximated as summations of discrete data that is gathered on a uniform grid in theta and phi. This leads to the figure of merit expressions given in [Appendix B.3](#).

As described in [Section 2](#) of this test plan, measurements may be taken with different positioner systems that gather data in different orders. For example, a conic-cut system might increment theta in the nominal range of 0 to 180 degrees (0 to π radians), and record a complete scan of phi from 0 to 360 degrees (0 to 2π radians) at each theta increment, while a great-circle-cut system might increment phi in the range of 0 to 180 degrees, and record a complete rotation of theta from 0 to 360 degrees at each phi increment. However, both systems will record measurements at the same points relative the EUT or head phantom, as described in [Section 2](#) and [Appendix A](#). Hence, regardless of the order in which the data are actually gathered, they can be recast into the standard nominal ranges of theta from 0 to 180 degrees (0 to π radians) and phi from 0 to 360 degrees (0 to 2π radians) that correspond to the standard right-hand spherical coordinate system. Such a data set is the starting point for the development in this subsection.

Assume that data are available at uniform angular intervals in theta and phi. There are N intervals in theta from 0 to π radians, and M intervals in phi from 0 to 2π radians. Let i be the index variable used to denote the theta measurement points (i ranges from 0 to N), and j be the index variable used to denote the phi measurement points (j ranges from 0 to M). A given angle (sample point) is then specified as (θ_i, ϕ_j) , with $(\theta_0, \phi_0) = (0, 0)$ and $(\theta_N, \phi_M) = (\pi, 2\pi)$. N and M are chosen, depending on the type of test, to yield the correct angular intervals specified in the test plan. For transmit testing, the angular interval is specified as 15 degrees, so N is $180/15 = 12$ and M is $360/15 = 24$. For receive testing, the angular interval is specified as 30 degrees, so N is $180/30 = 6$ and M is $360/30 = 12$. In summary:

- N = number of angular intervals in the nominal theta range from 0 to π
- M = number of angular intervals in the nominal phi range from 0 to 2π
- i = index for each theta sample, i ranges from 0 to N
- j = index for each phi sample, j ranges from 0 to M

Then the theta and phi intervals are:

EQUATION E.10

$$\Delta\theta = \theta_i - \theta_{i-1} = \frac{\pi}{N}$$

$$\Delta\phi = \phi_j - \phi_{j-1} = \frac{2\pi}{M}$$

Returning now to [Equation E.9](#), the inner (Phi) integral can be approximated using the trapezoidal rule [\[8\]](#) as

$$I \cong \frac{1}{4\pi} \int_{\theta=0}^{\pi} \frac{\Delta\phi}{2} \sum_{j=0}^{M-1} [K(\theta, \phi_j) + K(\theta, \phi_{j+1})] \sin(\theta) d\theta$$

This is rearranged in the conventional fashion as

$$I \cong \frac{1}{4\pi} \int_{\theta=0}^{\pi} \left[\Delta\phi \sum_{j=1}^{M-1} K(\theta, \phi_j) + \frac{\Delta\phi}{2} [K(\theta, \phi_0) + K(\theta, \phi_M)] \right] \sin(\theta) d\theta$$

Since $\phi_0 = 0$ and $\phi_M = 2\pi$, $K(\theta, \phi_0) = K(\theta, \phi_M)$ and the redundant measurement at ϕ_M need not be taken. The summation also then reduces to:

$$I \cong \frac{\Delta\phi}{4\pi} \int_{\theta=0}^{\pi} \sum_{j=0}^{M-1} K(\theta, \phi_j) \sin(\theta) d\theta$$

Applying the trapezoidal approximation now to the theta integration:

$$I \cong \frac{\Delta\phi}{4\pi} \left\{ \Delta\theta \sum_{i=1}^{N-1} \sum_{j=0}^{M-1} K(\theta_i, \phi_j) \sin(\theta_i) + \frac{\Delta\theta}{2} \left[\sum_{j=0}^{M-1} K(\theta_0, \phi_j) \sin(\theta_0) + \sum_{j=0}^{M-1} K(\theta_N, \phi_j) \sin(\theta_N) \right] \right\}$$

Since $\theta_0 = 0$ and $\theta_N = \pi$, $\sin(\theta_0) = \sin(\theta_N) = 0$, and the entire second term drops out, leaving:

$$I \cong \frac{\Delta\phi\Delta\theta}{4\pi} \sum_{i=1}^{N-1} \sum_{j=0}^{M-1} K(\theta_i, \phi_j) \sin(\theta_i)$$

Using [Equation E.10](#), this becomes:

EQUATION E.11

$$I \cong \frac{\pi}{2NM} \sum_{i=1}^{N-1} \sum_{j=0}^{M-1} K(\theta_i, \phi_j) \sin(\theta_i)$$

It is important to note from [Equation E.11](#) that the sample points (θ_i, ϕ_j) only need to be recorded for $i = 1$ through $N - 1$, and for $j = 0$ through $M - 1$. Thus, no data need be recorded at positions corresponding to $\theta = 0$ and 180 degrees, nor at positions corresponding to $\phi = 360$ degrees ($\phi = 0$ data are recorded), because those points are not used in [Equation E.11](#). For transmit tests with $N = 12$ and $M = 24$, this means that only 11 theta cuts and 24 phi cuts, or 264 measurements in each polarization, need be taken. For receive tests with $N = 6$ and $M = 12$, only 5 theta cuts and 12 phi cuts, or 60 measurements in each polarization, need be taken.

Applying the discretization [Equation E.11](#) to the TIS integral [Equation E.5](#), we have:

EQUATION E.12

$$TIS = \frac{4\pi}{\oint \left[\frac{1}{EIS_{\theta}(\theta, \phi)} + \frac{1}{EIS_{\phi}(\theta, \phi)} \right] \sin(\theta) d\phi d\theta} \cong \frac{1}{\frac{\pi}{2NM} \sum_{i=1}^{N-1} \sum_{j=0}^{M-1} \left[\frac{1}{EIS_{\theta}(\theta_i, \phi_j)} + \frac{1}{EIS_{\phi}(\theta_i, \phi_j)} \right] \sin(\theta_i)}$$

or

$$TIS \cong \frac{2NM}{\pi \sum_{i=1}^{N-1} \sum_{j=0}^{M-1} \left[\frac{1}{EIS_{\theta}(\theta_i, \phi_j)} + \frac{1}{EIS_{\phi}(\theta_i, \phi_j)} \right]} \sin(\theta_i)$$

where N and M are of course chosen as those values appropriate for the receive testing, 6 and 12, respectively.

Applying the discretization [Equation E.11](#) to the TRP integral [Equation E.8](#), we have:

EQUATION E.13

$$TRP = \frac{1}{4\pi} \int_{\theta=0}^{\pi} \int_{\phi=0}^{2\pi} (EiRP_{\theta}(\theta, \phi) + EiRP_{\phi}(\theta, \phi)) \sin(\theta) d\phi d\theta \cong \frac{\pi}{2NM} \sum_{i=1}^{N-1} \sum_{j=0}^{M-1} (EiRP_{\theta}(\theta_i, \phi_j) + EiRP_{\phi}(\theta_i, \phi_j)) \sin(\theta_i)$$

or

$$TRP \cong \frac{\pi}{2NM} \sum_{i=1}^{N-1} \sum_{j=0}^{M-1} [EiRP_{\theta}(\theta_i, \phi_j) + EiRP_{\phi}(\theta_i, \phi_j)] \sin(\theta_i)$$

where N and M in this case are 12 and 24, respectively.

[Equation E.12](#) and [Equation E.13](#) are the TIS and TRP figures of merit, which are delineated in [Appendix B.3](#).

Appendix F Symmetry Pattern Antenna (Informative)

The pattern symmetry requirement specified in [Section 3](#) should not be misinterpreted as an absolute accuracy requirement. A requirement of ± 0.1 dB for antenna pattern measurements taken in the cellular and PCS bands would be very challenging to accomplish. To clarify pattern symmetry, and provide context for selecting its value, the following is provided for informational purposes only.

F.1 Symmetry Pattern vs. Absolute Accuracy

The expanded uncertainty budget required by this test plan is cited in [Section 7.5](#). Given this specification, consideration must be given to the many items in the complete uncertainty budget that contribute to this final total. Examples of these are the uncertainty of the instrument used to measure absolute power (e.g., spectrum analyzer or power meter), the uncertainty with which the gain of the Calibrated Reference Antenna was measured, quiet zone accuracy (i.e., ripple or reflection in the chamber), etc. Many of these uncertainty contributions can be made quite small at these frequency ranges. Three-dimensional pattern integration of the Calibrated Reference Antenna can yield very precise directivity references. In the case of measuring highly non-directive devices, the two largest single contributors to the uncertainty budget are usually the ultimate accuracy of the power measurement instrument, and the quiet zone accuracy (ripple) in the anechoic chamber.

To obtain the overall uncertainty desired, it is likely that a quiet zone ripple substantially better than ± 1.0 dB is required. To quantify the quiet zone accuracy, an antenna (i.e., the omni-directional dipole or loop source) substantially better than the ± 1.0 dB ripple level discerned, therefore, should be used. Thus, the omni-directional test antennas used for the chamber evaluation given in [Section 3](#) (not necessarily for the Range Reference Measurement) are required to have patterns that are symmetric to ± 0.1 dB. This level of pattern symmetry is achieved rather easily with an electric dipole rotated about its axis, and can be achieved with some care with the uniform-current (Alford) loops described in this section. (Reference can also be made to, e.g., *Loop Antennas with Uniform Current*, Proc. IRE, vol. 32, pp. 603-607, October, 1944.)

Pattern symmetry is measured with an antenna centered precisely on the azimuth axis of rotation of the positioner. An anechoic chamber with a very low reflectivity is not required to verify a nominally omni-directional antenna's pattern symmetry. If an antenna with a perfectly symmetric omni pattern is precisely on the center of rotation, even if there is a substantial reflector in the chamber, a perfectly uniform pattern can be observed. This is because the signals on both the direct and reflected paths remain constant as the antenna is rotated. So, as long as an "omni" antenna starts out more or less omni, it can be qualified for pattern symmetry in a chamber that might not meet even the ± 1.0 dB quiet zone ripple referred to above.

It is important to note this specification calls for pattern SYMMETRY of ± 0.1 dB -- NOT absolute gain accuracy. In fact, for the chamber evaluation detailed in [Section 3](#) (not the Range Reference Measurement) phase, gain is not needed at all—only verification of the pattern symmetry. Furthermore, the ± 0.1 dB symmetry requirement is not arbitrary; it follows directly from the desire to meet the expanded uncertainty budgets cited in [Section 7.5](#).

To summarize, this specification does not require chamber evaluation antennas with a gain accuracy of ± 0.1 dB. Rather, the antenna pattern symmetry should be ± 0.1 dB, which is achievable and quantifiable.

Appendix G Instructions for Calculating Standard Uncertainty Values (Normative)

G.1 Mismatch

This uncertainty contribution addresses variation in the test system VSWR that introduces measurement uncertainty. For modern automated test systems used for OTA testing, it is expected that there will be considerable impedance mismatch between the various RF cables and components used within the system. Standing waves result in cables between points of mismatch that can cause variations in the signal levels measured. At the frequencies of interest, longer cables tend to be self-attenuating, resulting in a reduction in the standing wave contribution. In other cases, attenuators may be added at connection ports to reduce standing wave effects. The assumption made here is that any standing wave contributions in the cable only serve to modify the resultant signal level, but do not introduce sufficient time delay to corrupt the digital communication being measured. In this case, the error in a measurement due to mismatches throughout the system is caused by the difference in the VSWR between the calibration step (where the path loss of cables and other components of the measurement system is determined) and the measurement step (where those cables and components are used in a power or sensitivity measurement). If only the magnitude of the mismatch at a given connection were to change, then the measurement uncertainty for that change could be estimated using the difference in VSWR magnitudes before and after the change. However, more often, the change in the system also entails a change in cable lengths between two mismatches. That change in cable length results in a change in the frequency dependence of the mismatch, which makes it impractical to try to consider the difference between VSWR values to determine the uncertainty. Instead, the VSWR uncertainty due to each mismatch where a cable connection is changed must be applied to determine the appropriate measurement uncertainty contributions.

The maximum error due to VSWR between two ports is given in general form by the following equation:

EQUATION G.1

$$\epsilon_{VSWR} = 20 \log \left(1 + |\Gamma_1| \times |\Gamma_2| \times |S_{21}| \times |S_{12}| \right)$$

where Γ_1 and Γ_2 are the complex reflection coefficients of the two ports in question and S_{21} and S_{12} are the forward and reverse transmission coefficients between the two ports. From this it is evident that reducing the reflection coefficients (by reducing mismatches) or reducing the transmission coefficients (by adding attenuation) will reduce the resulting error contribution. The reflection coefficient can be expressed in terms of the VSWR at a given connector by [Equation G.2](#):

EQUATION G.2

$$|\Gamma| = \frac{VSWR - 1}{VSWR + 1}$$

From this equation, a simpler two-port formulation can be derived to represent the VSWR error contribution due to the reflectivity of each side of a cable connection point. This allows estimating the required uncertainty contribution by simply measuring the reflection coefficients of each side of a cable connection that is changed between the calibration and measurement steps.

EQUATION G.3

$$\begin{aligned}\varepsilon_{VSWR} &= 20 \log \left(1 + |\Gamma_1| \times (|\Gamma_2| \times |S_{21}| \times |S_{12}|) \right) \\ &= 20 \log \left(1 + |\Gamma_{source}| \times |\Gamma_{load}| \right)\end{aligned}$$

where Γ_{source} and Γ_{load} are the complex reflection coefficients of the cable/connector ends looking towards the source or load respectively.

For a typical OTA system, there are four principal cable junctions to evaluate: 1) the loopback cable connection made to calibrate out cable losses and test equipment factors during the range calibration; 2) the connection between the “transmit” cable and the reference antenna placed within the quiet zone; 3) the connection between the measurement port cable of the test system (the cable normally connected to the test equipment to route signals to or from the measurement antenna) and the loopback cable; and 4) the connection of the measurement port cable to the test equipment. The impact of the first three contributions can be minimized through the use of appropriate attenuators at the end of the transmit and loopback cables. The fourth term can be reduced through the addition of an attenuator that remains in the measurement system on the end of the cable leading to the measurement instrument.

An additional term has traditionally been evaluated related to the potential of the EUT to alter the VSWR of the measurement antenna. Generally, any change in VSWR sufficient to produce a notable uncertainty contribution would likely be due to the EUT being within the reactive region of the measurement antenna, or otherwise large enough to violate other range length requirements. However, the variability of the measurement antenna VSWR in the presence of different EUTs should be evaluated to confirm that this contribution is negligible, and in the event that any variation is detected, an appropriate measurement uncertainty term shall be included.

Since the error due to VSWR has a sinusoidal nature, it causes a deviation that clusters equally above and below the initial transmitted signal. This U-shaped distribution must be converted to an equivalent normal distribution probability by using the following equation to determine the standard uncertainty.

EQUATION G.4

$$u_i = \frac{a_i}{\sqrt{2}} = \frac{\varepsilon_{VSWR}}{\sqrt{2}}$$

G.2 Cable Factor

This uncertainty applies to the Measurement Antenna only.

For cases in which the Measurement Antenna is directional (i.e. peak gain greater than +5 dBi e.g. horn, LPDA, etc.), the standard uncertainty should be taken as 0.00 dB. For all other cases of Measurement Antenna gain (i.e. dipole, sleeve dipole, loop, etc.), the following rules apply:

- If nothing has been changed in the time interval between the Range Reference Measurement and the EUT measurement, the interaction of the cable (whether it is 'dressed' in ferrites and/or a balun) will be the same in both parts of the test, so a fixed value of 0.00 dB shall be taken for the expanded uncertainty contribution.
- If the cable has been changed or moved to a different routing, but the dressing with ferrites and/or a balun remains the same (or similar), then a fixed value of 0.50 dB shall

- be taken and its distribution shall be assumed to be rectangular (i.e. standard uncertainty = 0.29 dB).
- If the dressing has been changed and ferrites and/or balun have only been present in one of the parts of the test, then 0.00 dB shall be entered in the measurement part of the test, and 4.00 dB in the Range Reference Measurement (justification for these values can be found in Annex A, section A.5 and Annex E in TR 102 273).

G.3 Insertion Loss

Where the same cable on the input to the Measurement Antenna has been used in both parts of the test, then a fixed value of 0.00 dB shall be entered into the tables for both parts of the test.

Where any cable is used in only one part of the test (e.g. the Range Reference Measurement) and its insertion loss is used in the calculations, then either the overall combined standard uncertainty of the insertion loss measurement shall be used in the relevant table or the manufacturer's data sheet shall be consulted. In the latter case, this uncertainty will usually be quoted as $\pm x$ dB. Unless something specific is stated about the distribution of this uncertainty, it should be assumed to be rectangularly distributed, in which case the standard uncertainty shall be calculated as: $\frac{\text{maximum value}}{\sqrt{3}}$.

G.4 Receiving Device (Spectrum Analyzer, Measurement Receiver or Base Station Simulator)

The receiving device is used to measure the received signal level in TRP tests either as an absolute level or as a reference level. It can generally contribute uncertainty components in two ways: absolute level accuracy and non-linearity. Both components are present in the EUT part of the test, but only the non-linearity uncertainty is present in the Range Reference Measurement, with the exception of cases where one of the optional transfer standard methods is used to apply the absolute accuracy of one instrument as a correction to that of another.

For relative measurements, if the same receiver is used to measure both test configurations, then the receiving device is used to measure the relative received signal levels. The receiving device can generally contribute uncertainty components in terms of non-linearity for this measurement. If two different instruments are used (including, possibly, two different options in the same base station simulator) then the absolute uncertainties of both devices will contribute. So the absolute uncertainty for the second receiver would be included as an additional uncertainty.

These uncertainty contributions shall be taken from the manufacturer's data sheet and converted to dB if necessary. The worst case data sheet values shall be used.

Note that the measurement uncertainty specification of the instrument may vary as a function of the chosen bandwidth setting or other parameters. The lab shall ensure that appropriate manufacturer's uncertainty contributions are specified for the settings used.

G.5 Signal Generator or Base Station Simulator

In a similar manner to the receiving device, the signal generator or base station simulator can contribute in two ways (absolute level and stability) to the uncertainty in, respectively, the Range Reference Measurement and the TIS measurement. In the case of a network analyzer used for the Range Reference Measurement, the signal generator is combined with the receiver in one unit that measures the relative difference between the output signal and received signal. Thus, the uncertainty contribution of the signal generator is included in one overall uncertainty contribution of the instrument, and does not need to be entered separately.

For relative measurements, if the same base station simulator is used to measure both test configurations, then it is used to measure the relative radiated sensitivity. In this case, the base station simulator will generally contribute uncertainty components in terms of non-linearity for the relative measurement. If two different instruments are used (including, possibly, two different options in the same base station simulator) then the absolute uncertainties of both devices will contribute. In that case the absolute uncertainty of the base station simulator for test configuration B would be included as an additional uncertainty.

These uncertainty contributions shall be taken from the manufacturer's data sheet and converted to dB if necessary.

1. If using the manufacturer's data sheet, the worst case values shall be used.
2. An allowed alternative is to use an alternate measurement device to normalize the signal generator RF output level.
3. An allowed alternative is to use the calibration report plus the MU and aging terms from the calibration lab.

For certain test configurations, the confidence level for BER/FER for measuring the sensitivity may be limited in order to keep the test time low. The measured sensitivity with lower confidence levels will have some small variation. For the full TIS measurements, the variation for each sensitivity reading will largely average out over the large number of sample points over the 3D sphere. However, for a single point measurement, this small variation in sensitivity shall be included as an uncertainty. One way to mitigate this uncertainty is to use a much higher confidence level (i.e. longer test time) to significantly reduce this uncertainty. For the multi-point measurement, the small variation in radiated sensitivity is averaged over multiple points and its uncertainty is reduced by the averaging process. Test measurements can be conducted to characterize the uncertainty associated with whichever test method (such as using a higher confidence level) is selected for the single/multi point radiated measurement.

G.6 Gain of the Calibrated Reference Antenna

For cases in which the Calibrated Reference Antenna is directional (i.e., peak gain greater than +5 dBi e.g. horn, LPDA, etc.), the standard uncertainty for the gain shall be taken as the reported value from its measurement.

For all other cases of Measurement Antenna gain (i.e., dipole, sleeve dipole, loop, etc.), the following rules apply:

- Where the gain of the Calibrated Reference Antenna has been measured in a different test chamber using the same mounting arrangements/jigs, the value of the standard uncertainty shall be taken as the reported value from that measurement.

- Where the gain of the Calibrated Reference Antenna has been measured in a different test chamber using different mounting arrangements/jigs, the value of the standard uncertainty shall be taken as the reported value from that measurement, combined by the RSS method with a contribution from the mounting arrangement/jig. A fixed value of 0.5 dB shall be taken and its distribution shall be assumed to be rectangular (i.e. standard uncertainty = 0.29 dB).
- Where the gain of the Calibrated Reference Antenna has been measured in the same test chamber (possibly by the 3-antenna method) using the same mounting arrangements/jigs, the value of the standard uncertainty shall be taken as that calculated for the measurement.

G.7 Measurement Distance

G.7.1 Offset of the Phase Center of the EUT from Center of Rotation

All head phantom measurements defined in this test plan require θ and ϕ rotation of the EUT and head phantom combination about the Ear Reference Point (assumed to be the location of the phase center) as the coordinate origin. As this may be practically impossible for a number of reasons (e.g. the turntable may be too small to allow adequate offset, etc.), an alternative of rotating about the center of the SAM head phantom is allowed. The center of the SAM head phantom is defined as the new origin of the coordinate system if the axes are translated 82 mm in the -Y direction from the original origin shown in [Figure A-3](#). The new alignment is shown in [Figure A-6](#). For this new alignment, an additional uncertainty contribution must be included in the calculation of measurement uncertainty for the EUT measurement because the phase center will rotate on a non-zero radius about the center of rotation, thereby giving a variable measurement distance.

The maximum level change due to this alternative positioning of the SAM head is:

$$20 \log_{10} \left(\frac{d}{d - 0.082} \right) \text{dB}$$

where d = range length i.e. the distance between the phase center of the measurement antenna and the axis of rotation of the turntable (ϕ -axis for distributed-axes positioner systems, θ -axis for combined-axes positioner systems).

Note: “ d ” is in meters.

Since this level change uncertainty is assumed to be rectangularly distributed, the standard uncertainty shall be derived by dividing the maximum level by $\sqrt{3}$.

G.7.2 Offset of the Phase Center of the Calibrated Reference Antenna from Center of Rotation

For the Range Reference Measurement (i.e. where the Calibrated Reference Antenna is involved), any uncertainty in the accuracy of positioning its phase center on the axis(es) of rotation will directly generate an uncertainty in this part of the measurement. For sleeve dipoles and loops, provided that care is taken in their positioning the uncertainty should be 0.00 dB since their phase centers are easily identifiable.

However, for ridged horn antennas and LPDAs (for both of which the position of the phase center varies with frequency), the phase center could be at any point within the tapered sections, giving:

For a ridged horn: A maximum positional uncertainty, $\pm d$, where d equals 0.5 times the length of taper

For an LPDA: A maximum positional uncertainty, $\pm d$, where d equals 0.5 times the length of the boom

The level uncertainty resulting from these positional uncertainties shall be calculated as:

$$\pm 20 \log_{10} \left(\frac{\text{measurement distance} - d}{\text{measurement distance}} \right)$$

Since this level uncertainty is assumed to be rectangularly distributed, the standard uncertainty shall be derived by dividing by $\sqrt{3}$.

G.7.3 Blocking Effect of the EUT on the Measurement Antenna (if too close)

This uncertainty arises because the EUT can 'block' the power radiated by the Measurement Antenna, reflecting the energy back into the antenna which, as a result, can change its input impedance/VSWR whilst also creating a standing wave within the chamber between the Measurement Antenna and EUT. The magnitudes of the resulting uncertainties are dependent on both the directionality of the Measurement Antenna and the measurement distance. The uncertainties increase with increasing directionality (i.e., increasing gain) of the Measurement Antenna and with decreasing measurement distance. The magnitudes of the effects will vary as the EUT and/or Measurement Antenna is rotated (since the 'blocking' area changes with angle), and therefore allowances for the uncertainties introduced shall be made.

Note: *These uncertainties only apply for tests of the EUT against the head phantom or for notebooks and other large form factor devices. The contributions can be expected to be worst for large flat reflecting objects such as a notebook display or large metallic housings. These terms may also apply to the range calibration in the event that the reference antenna has a large radar cross section. Note too that significant changes in VSWR at range lengths on the order of a few wavelengths from the reference channel may be indicative of the reference channel encroaching on the reactive region of the measurement antenna, thus invalidating measurement results.*

G.7.3.1 VSWR

This measurement uncertainty is due to a second order standing wave between the reference channel and any mismatch in the system cabling as seen from the measurement antenna. As described in [Appendix G.1](#), measurement uncertainty arises when the VSWR changes between the range calibration and EUT measurement steps.

To estimate the magnitude of this uncertainty, [Equation G.5](#) is used to evaluate the potential standing wave contribution from reflections within the test volume to the first notable mismatch past the measurement antenna.

EQUATION G.5

$$\begin{aligned}\varepsilon_{VSWR} &= 20 \log \left(1 + |\Gamma_{EUT}| \times \frac{G_{MA} \lambda}{8\pi R} \times (|\Gamma_2| \times |S_{21}| \times |S_{12}|) \right) \\ &= 20 \log \left(1 + |\Gamma_{EUT}| \times \frac{G_{MA} \lambda}{8\pi R} \times |\Gamma_{load}| \right)\end{aligned}$$

Where $G_{MA} \lambda / 8\pi R$ is a modified version of the Friis transmission equation representing the measurement antenna (MA) with linear power gain G_{MA} both transmitting and receiving the signal reflected from the EUT at a distance R from the MA, for a total distance of $2R$. Since the gain of the measurement antenna includes the effect of mismatch on the antenna, there is no need to further evaluate the VSWR of the measurement antenna itself. The S-Parameters in Γ_{load} correspond to the path loss of any cables and attenuators between the measurement antenna and the first significant mismatch Γ_2 . As described in [Appendix G.1](#), this can be replaced by a single measurement of the mismatch at the end of the cable attached to the measurement antenna. To determine the worst-case possible error contribution due to this term, Γ_{EUT} may be set to 1 to represent a perfectly reflecting metal plane normal to the measurement antenna boresight. The maximum error due to this term is then converted to a standard uncertainty contribution as described in [Appendix G.1](#).

Example: Range length: 1.2 m

Measurement antenna gain: 9 dB

Test frequency: 700 MHz

Cable loss: 3 dB

Mismatch at test equipment rack: 2:1

EQUATION G.6

$$\begin{aligned}\varepsilon_{VSWR} &= 20 \log \left(1 + \frac{10^{9/10} \times \frac{c}{7 \times 10^8}}{8\pi \times 1.2} \times \left(\frac{2-1}{2+1} \times 10^{-3/20} \times 10^{-3/20} \right) \right) \\ &= 20 \log \left(1 + \frac{7.94 \times 0.428}{8\pi \times 1.2} \times \left(\frac{1}{3} \times 0.707^2 \right) \right) \\ &= 0.16 \text{ dB}\end{aligned}$$

Note: Any significant change in the VSWR of the measurement antenna would imply a reactive region interaction, implying that the measurement antenna is too close to the EUT and thus the test system should not be used in this case.

G.7.3.2 Chamber Standing Wave

In addition to the second order VSWR term described above, there is the potential for a standing wave reflection between the measurement antenna and the EUT, representing an additional chamber ripple term beyond that recorded in the ripple test. While this contribution may tend to average out over the surface of an irregular object, that cannot be guaranteed. This term is also a function of the reflectivity of the measurement antenna, which may be difficult to determine empirically. If a measured or manufacturer specified reflectivity is unavailable, then for the purpose of this contribution, the reflectivity of the measurement antenna shall be assumed to be the gain of the measurement antenna multiplied by the reflectivity corresponding to the VSWR of the MA. Thus, Equation G.6 above becomes:

EQUATION G.7

$$\varepsilon_{VSWR} = 20 \log \left(1 + |\Gamma_{EUT}| \times \frac{G_{MA} \lambda}{8\pi R} \times |\Gamma_{MA_VSWR}| \right)$$

Given the same example parameters above, and a measurement antenna VSWR of 2.5:1, this contribution then becomes:

EQUATION G.8

$$\begin{aligned} \varepsilon_{VSWR} &= 20 \log \left(1 + \frac{10^{9/10} \times \frac{c}{7 \times 10^8}}{8\pi \times 1.2} \times \frac{2.5-1}{2.5+1} \right) \\ &= 20 \log \left(1 + \frac{7.94 \times 0.428}{8\pi \times 1.2} \times .429 \right) \\ &= 0.41 \text{ dB} \end{aligned}$$

If a free-space reflectivity of the measurement antenna is available, Equation G.8 simplifies to:

EQUATION G.9

$$\varepsilon_{VSWR} = 20 \log \left(1 + |\Gamma_{EUT}| \times \frac{\lambda}{8\pi R} \times |\Gamma_{MA}| \right)$$

G.7.4 Additional Measurement Uncertainties for Inadequate Measurement Distance

The minimum measurement distances given in Table 3-1 are based on industry accepted “rules of thumb” for single point measurements. The assumption in the test plan is that meeting these minimum measurement distances will result in negligible measurement uncertainty due to measurement distance. Additional measurement uncertainty contributions are required for measurement distances that are less than the distances given in Table 3-1. These additional measurement uncertainty contributions are shown in Table G-1.

TABLE G-1 CONTRIBUTIONS FOR INADEQUATE MEASUREMENT DISTANCE

Band	Lower Frequency (MHz)	Upper Frequency (MHz)	Required Measurement Distance (m)	MU Contributions for Inadequate Range Length						
				R = 1.2m	R ≥ 1.29m	R ≥ 1.43m	R ≥ 1.5m	R ≥ 1.60m	R ≥ 2.22m	R ≥ 3.56m
3GPP Band 71	617	698	1.46	0.2	0	0	0	0	0	0
3GPP Band 12	699	746	1.29	0.2	0	0	0	0	0	0
3GPP Band 17	704	746	1.28	0.2	0	0	0	0	0	0
3GPP Band 29	717	728	1.26	0.2	0	0	0	0	0	0
3GPP Band 13	746	787	1.21	0	0	0	0	0	0	0
3GPP Band 70 RX	1995	2020	1.21	0	0	0	0	0	0	0
AWS-1 RX (3GPP Band 4 RX)	2110	2155	1.29	0.2	0	0	0	0	0	0
3GPP Band 66 RX	2110	2170	1.29	0.2	0	0	0	0	0	0
3GPP Band 30	2305	2360	1.42	0.2	0.1	0	0	0	0	0
3GPP Band 41	2496	2690	1.61	0.2	0.1	0.1	0.1	0	0	0
3GPP Band 7	2500	2690	1.61	0.2	0.1	0.1	0.1	0	0	0
3GPP Band 48	3550	3700	2.22	0.2	0.1	0.1	0.1	0	0	0
3GPP Band 46	5150	5925	3.56	0.2	0.1	0.1	0.1	0	0	0

The MU contributions in [Table G-1](#) were determined by making a TRP measurement on a passive antenna at different range lengths. The same data sets were then transformed to far-field data using a spherical near-field-to-far-field transform. The output of the transform is the data with all of the effects of range length removed. The TRP was then re-calculated using the far-field data. The difference between the TRP calculated using the finite measurement distances and the infinite measurement distances was then used to establish the measurement uncertainty contributions in [Table G-1](#). The details of these measurements can be found in [\[23\]](#).

Note that the uncertainty contributions in [Table G-1](#) should be included in the measurement uncertainty calculations for the simulated use case. They should not be included in the measurement uncertainty calculations for the free space use case or the reference measurement.

G.8 Signal Level Ripple Within Quiet Zone

The signal level ripple is measured during the chamber proving procedures detailed in [Section 3](#), using omni-directional probe antennas (sleeve dipoles and loops). The ripple test provides a very thorough measurement of the interaction of the chamber and positioning equipment with different signal paths throughout the quiet zone. The ripple test result represents a worst-case deviation in EIRP or EIS for a theoretical isotropic radiator/receiver or an omni-directional radiator/receiver with the same orientation as the ripple test. Suitable values for the measurement uncertainties associated with different measurement quantities can be determined as follows.

G.8.1 Effect of Ripple on TRP and TIS Integration

In TRP and TIS tests, the test metric (quantity used for comparison between EUTs) is the result of a spherical surface integral of the EIRP or EIS. In order to estimate the effect of a single EIRP/EIS point on the total integrated value, it is necessary to define a statistical uncertainty value referred to as the surface standard deviation (SSD). The SSD uses the ripple test results to determine a Type A uncertainty value for a theoretical isotropic radiator placed anywhere within the quiet zone. Empirical results of both measured and calculated omni-directional and directional antennas indicate that the uncertainty predicted by the SSD of the ripple encompasses the variation in the TRP/TIS integral value for the expected range of EUT patterns.

The standard deviation from a sample of N readings is given by:

EQUATION G.10

$$s(q_k) = \sqrt{\frac{1}{(N-1)} \sum_{k=0}^{N-1} (q_k - \bar{q})^2}$$

In terms of relative deviations in linear power, this becomes:

EQUATION G.11

$$s(p_k) = \sqrt{\frac{1}{(N-1)} \sum_{k=0}^{N-1} \left(\frac{p_k}{\bar{p}} - 1 \right)^2}$$

where p_k is an individual ripple measurement point, converted to linear units

($p_k = 10^{p_k(dB)/10}$), and \bar{p} is the average of the associated ripple measurement, again in linear units. This formulation provides the SSD for the phi-axis ripple test, since the contribution of the EIRP/EIS to the surface integral is the same at each phi angle.

For the theta-axis ripple, the contribution of each EIRP/EIS point to the surface integral is dependent on the theta angle, and therefore, so does any error contribution due to that point. The spherically weighted contribution becomes:

EQUATION G.12

$$s(p_k) = \sqrt{\frac{1}{(N-1)} \sum_{k=0}^{N-1} \left[\left(\left(\frac{p_k}{\bar{p}} - 1 \right) \sin(\theta_k) \right)^2 \right]}$$

Note: This simplifies to the previous equation when $\theta = 90$.

The standard uncertainty contribution due to the ripple test is then given by the maximum of all the $s(p_k)$ values for all orientations, offsets, and polarizations of the ripple test:

EQUATION G.13

$$u(x) = 10 \log(1 + \max(s_j(p_k)))$$

Equation G.13 represents the value to be placed in Table 7-2 for $N > 50$. For $N \leq 50$, an appropriate coverage factor should be applied.

G.8.1.1 Applying the Surface Standard Deviation

Repeat the following steps for each required band and positioning system configuration (free-space vs. SAM head phantom, etc.) to generate the uncertainty for that configuration.

For each ripple test measurement:

- Compute the linear average of the ripple value.
- Calculate the spherically weighted surface standard deviation using Equation G.12. Use $\theta = 90$ for phi-axis ripple test results.
- Select the maximum SSD from all 13 ripple test positions and calculate the standard uncertainty in dB using Equation G.13. This value shall be used directly in the uncertainty budget in Table 7-2.

G.8.1.2 Analysis of Uncertainty vs. Error Contribution

In order to provide some confidence in the uncertainty values produced by this method, it is useful to compare the actual error contribution to a TRP/TIS integral to the uncertainty predicted by a ripple test. This can only be performed rigorously by assuming an isotropic radiation pattern for the EUT, but, as mentioned above, the result is deemed reliable for other non-isotropic EUTs of interest to this test plan. It is easy enough to test specific cases and show that the SSD expanded uncertainty encompasses the TRP/TIS error for likely real pattern shapes. This formulation will refer solely to TRP, but the same procedure can be followed for TIS. Starting with Equation B.1:

EQUATION G.14

$$TRP \cong \frac{\pi}{2NM} \sum_{i=1}^{N-1} \sum_{j=0}^{M-1} [EiRP_{\theta}(\theta_i, \phi_j) + EiRP_{\phi}(\theta_i, \phi_j)] \sin(\theta_i)$$

In terms of total EIRP and an associated error term at each point, this becomes:

EQUATION G.15

$$TRP + Error_{TRP} \cong \frac{\pi}{2NM} \sum_{i=1}^{N-1} \sum_{j=0}^{M-1} [EiRP_{Total}(\theta_i, \phi_j) + Error(\theta_i, \phi_j)] \sin(\theta_i)$$

which can be represented as a relative TRP error as:

EQUATION G.16

$$1 + \frac{Error_{TRP}}{TRP} \cong \frac{\frac{\pi}{2NM} \sum_{i=1}^{N-1} \sum_{j=0}^{M-1} [EiRP_{Total}(\theta_i, \phi_j) + Error(\theta_i, \phi_j)] \sin(\theta_i)}{\frac{\pi}{2NM} \sum_{i=1}^{N-1} \sum_{j=0}^{M-1} EiRP_{Total}(\theta_i, \phi_j) \sin(\theta_i)}$$

which simplifies to:

EQUATION G.17

$$\frac{Error_{TRP}}{TRP} \cong \frac{\sum_{i=1}^{N-1} \sum_{j=0}^{M-1} Error(\theta_i, \phi_j) \sin(\theta_i)}{\sum_{i=1}^{N-1} \sum_{j=0}^{M-1} EiRP_{Total}(\theta_i, \phi_j) \sin(\theta_i)}$$

In a ripple test, the variation occurs along only one axis of rotation, so it's possible to simplify this equation further. Although either axis could be held constant, the following formulation will assume that the ripple is along the theta axis. The phi axis result is similar. Substituting in the theta ripple test geometry results in the following equation:

EQUATION G.18

$$\frac{Error_{TRP}}{TRP} \cong \frac{\sum_{i=1}^{N-1} Error(\theta_i) \sin(\theta_i)}{\sum_{i=1}^{N-1} EiRP_{Total}(\theta_i) \sin(\theta_i)}$$

Assuming $N > 50$, the expanded uncertainty for a 95% confidence level ($k = 2$) is just:

EQUATION G.19

$$U = 2 u(x)$$

The linear representation of the expanded uncertainty is given by:

EQUATION G.20

$$U_{lin} = (1 + s_{\max}(p_k))^2 = \left(1 + \sqrt{\frac{1}{(N-1)} \sum_{k=0}^{N-1} \left[\left(\left(\frac{p_k}{\bar{p}} - 1 \right) \sin(\theta_k) \right)^2 \right]} \right)^2$$

Assume that the relative ripple from the ripple test, $(p_k / \bar{p} - 1)$, is equivalent to the relative error at a given EIRP point, $Error(\theta_i, \phi_j) / EiRP_{Total}(\theta_i, \phi_j)$, so that the theta-axis ripple gives:

EQUATION G.21

$$U_{lin} = \left(1 + \sqrt{\frac{1}{(N-1)} \sum_{i=0}^{N-1} \left[\left(\frac{Error(\theta_i)}{EiRP_{Total}(\theta_i)} \sin(\theta_i) \right)^2 \right]} \right)^2$$

We can normalize the $Error / EiRP_{Total}$ ratio such that $EiRP_{Total}$ is one everywhere (equivalent to an isotropic radiator) and define a new error term, as the relative error at each EIRP point. The expanded uncertainty then simplifies to:

EQUATION G.22

$$U_{lin} = \left(1 + \sqrt{\frac{1}{(N-1)} \sum_{i=0}^{N-1} [(Error'(\theta_i) \sin(\theta_i))^2]} \right)^2$$

In the limiting case of $Error'(\theta_i) = 0$, this reduces to $U_{lin} = 1$ so that $U = 0$ dB. For an isotropic radiator, the TRP error equation becomes:

EQUATION G.23

$$Error'_{TRP} \cong \frac{\sum_{i=1}^{N-1} Error'(\theta_i) \sin(\theta_i)}{\sum_{i=1}^{N-1} \sin(\theta_i)} = \frac{\sum_{i=1}^{N-1} Error'(\theta_i) \sin(\theta_i)}{2(N-1)/\pi}$$

In the limiting case of $Error'(\theta_i) = 0$, this reduces to $Error'_{TRP} = 0$. The corresponding linear value for comparison to the uncertainty is given by $1 + Error'_{TRP}$. When $Error'_{TRP} = 0$, this results in a 0 dB error. It should be noted that the relative error can never be less than -1 since that would imply that $TRP + Error_{TRP} < 0$, which is impossible. Comparing these two formulations gives:

EQUATION G.24

$$\left(1 + \sqrt{\frac{1}{(N-1)} \sum_{i=0}^{N-1} [(Error'(\theta_i) \sin(\theta_i))^2]} \right)^2 \quad \text{and} \quad 1 + \frac{\sum_{i=1}^{N-1} Error'(\theta_i) \sin(\theta_i)}{2(N-1)/\pi}$$

Note the similarities between the two equations.

G.8.2 Effect of Ripple on Range Reference Measurement

In addition to the integration of TRP and TIS values, the Range Reference Measurement can potentially suffer the effects of the signal ripple. Since the range reference measurement may be performed with various support structure components removed, the impact on the measurement uncertainty is based only on the ripple of components remaining in the test volume during the calibration process. The value of the uncertainty component arising from ripple depends on the directivity of the reference antenna, with higher gain antennas typically seeing lower chamber induced ripple, but more uncertainty related to the reference gain and phase center position of the reference antenna.

- Where the Calibrated Reference Antenna is a sleeve dipole or magnetic loop placed in the center of the test volume, the standard uncertainty shall be calculated by dividing the

maximum ripple of the chamber as configured for the range calibration by $\sqrt{3}$ since the uncertainty is considered to be rectangularly distributed. In cases where advanced calibration methods are used to minimize this contribution (e.g. ripple or efficiency based calibrations as described in Section 4, this contribution may be further divided by \sqrt{N} , where N is the number of data points used in the averaging measurement.

- Where the Calibrated Reference Antenna is a ridged horn, the positional uncertainty (assuming the phase center is unknown) shall be considered equal to 0.5 times the length of the flared section. The resulting signal level ripple shall be taken as:

$$\sin\left(\left(\frac{0.5 \times \text{length of flared section in mm}}{150}\right) \times 0.90\right) \times \text{max ripple}$$

and the standard uncertainty calculated by dividing by $\sqrt{3}$ since the uncertainty is considered to be rectangularly distributed.

- Where the Calibrated Reference Antenna is a LPDA, the positional uncertainty (assuming the phase center is unknown) shall be considered equal to ± 0.5 times the length. The resulting signal level ripple shall be taken as:

$$\sin\left(\left(\frac{0.5 \times \text{length in mm}}{150}\right) \times 0.90\right) \times \text{max ripple}$$

and the standard uncertainty calculated by dividing by $\sqrt{3}$ since the uncertainty is considered to be rectangularly distributed.

G.9 Influence Quantities

Temperature is the only influence quantity in the tests covered by this test plan. It influences test equipment used for TRP and TIS. This measurement uncertainty must be included when the test equipment is used outside of the certified temperature range.

TRP test

The ambient temperature uncertainty $\pm v$ in Kelvin is converted to a level uncertainty by means of formula 5.2 in ETSI TR 100 028 Part 1. The test laboratory making the measurements may, by means of additional measurements, estimate its own influence quantity dependencies, but if this is not carried out the values stated in table F.1 in ETSI TR 100 028 Part 2 should be used as worst-case values.

The standard uncertainty shall be calculated as:

$$u_{j \text{ temperature uncertainty}} = \frac{\sqrt{\left(\frac{(v_{temp})^2}{3}\right) \times \left((\mu_{power_avg})^2 + (\mu_{power_std})^2\right)}}{23} \text{ dB}$$

where

μ_{power_avg} is mean value of power measurement sensitivity in percentage per Kelvin (%/K). A worst-case value is 4 %/K for $k=2$ (see ETSI TR 100 028 Part 2).

μ_{power_std} is standard deviation of power dependence per Kelvin. A worst-case value is 1.2 %/K for $k=2$ (see ETSI TR 100 028 Part 2).

Example of a typical measurement uncertainty calculation:

Ambient temperature uncertainty = ± 1 K.

$$u_{j \text{ temperature uncertainty}} = \frac{\sqrt{\left(\frac{(1\text{K})^2}{3}\right) \times \left((4\%/K)^2 + (1.2\%/K)^2\right)}}{23} = 0.10\text{dB}$$

Note: The μ_{power_avg} and μ_{power_std} are used as percentage changes per Kelvin and temperature v_{temp} in Kelvin.

TIS test

The ambient temperature uncertainty $\pm v$ in Kelvin is converted to a level uncertainty by means of formula 5.2 in ETSI TR 100 028 Part 1. The test laboratory making the measurements may, by means of additional measurements, estimate its own influence quantity dependencies, but if this is not carried out the values stated in table F.1 in ETSI TR 100 028 Part 2 should be used as worst-case values.

The standard uncertainty shall be calculated as:

$$u_{j \text{ temperature uncertainty}} = \frac{\sqrt{\left(\frac{(v_{temp})^2}{3}\right) \times \left((\mu_{voltage_avg})^2 + (\mu_{voltage_std})^2\right)}}{11.5} \text{dB}$$

where

$\mu_{voltage_avg}$ is mean value of voltage measurement in percentage per Kelvin (%/K). A worst-case value is 2.5 %/K for $k=2$ (see ETSI TR 100 028 Part 2).

$\mu_{voltage_std}$ is standard deviation of voltage dependence per Kelvin. A worst-case value is 1.2 %/K for $k=2$ (see ETSI TR 100 028 Part 2).

Example of a typical measurement uncertainty calculation:

Ambient temperature uncertainty = ± 3 K.

$$u_{j \text{ temperature uncertainty}} = \frac{\sqrt{\left(\frac{(3\text{K})^2}{3}\right) \times \left((2.5\%/K)^2 + (1.2\%/K)^2\right)}}{11.5} = 0.42\text{dB}$$

Note: The $\mu_{voltage_avg}$ and $\mu_{voltage_std}$ are used as percentage changes per Kelvin and temperature v_{temp} in Kelvin.

G.10 Uncertainties of Head, Hand and Positioning of EUT in the Hand and Against the Head Phantoms

This uncertainty component arises from:

- The tolerance of head shape, shell thickness and dielectric parameters and mounting construction
- The tolerance of hand shape and mounting fixture
- Positioning the phone in the hand and the hand with the phone at the head with respect to the definitions provided in [Appendix A](#).

The combined uncertainty of head, hand and EUT positioning in the hand and against the head phantoms as defined in [Section 7](#) shall be determined as:

TABLE G-2 STANDARD UNCERTAINTIES FOR THE HEAD, HAND AND EUT POSITIONING IN THE HAND AND AGAINST THE HEAD

Description of uncertainty contributions	Standard Uncertainty, dB
Head Phantom Uncertainty	See Appendix G.10.2
Hand Phantom Uncertainty	See Appendix G.10.3 and Appendix G.10.8
Head Phantom Fixture Uncertainty	See Appendix G.10.4
Hand Phantom Fixture Uncertainty	See Appendix G.10.4 and Appendix G.10.8
Phone Positioning Uncertainty	See Appendix G.10.5 and Appendix G.10.8
Combined Standard Uncertainty (root-sum-squares)	

G.10.1 Concept of Phantom and Positioning Uncertainties

The uncertainty components and the guidelines for their evaluation are such that the values can be assessed independent of the chamber performance, e.g., by the vendors. They shall represent the maximum uncertainty for the determination of TRP and TIS:

The measurement uncertainty estimate shall include the following frequency bands:

- 600-1176.45 MHz
- 1176.45-2200 MHz
- 2300-2800 MHz
- 3300-3800 MHz
- 5000-6000 MHz

The selected phones used in the evaluation shall be used to extrapolate the uncertainty to the entire phone population. Since the evaluation effort per phone can be significant, the total number of phones to be used in the evaluation is limited for practical reasons. Therefore worst-case considerations combined with statistical methods shall be applied. For guidance, see NIST [9].

For the 600-1176.45 MHz and 1176.45-2200 MHz bands, the number of phones shall be at least six and include at least:

- Two monoblock phones (fixed or portrait slides)
- Two fold phones

It is recommended to have two devices for the following three phantom hands defined in [Appendix A.1.4](#): monoblock, fold phone, and PDA grip. Preferably, at least one phone should have an antenna at the base of the phone, one should have an extended antenna, and one phone should have an antenna embedded in the back of the phone.

For the 2300-2800 MHz, 3300-3800 and 5000-6000 bands, at least 3 PDA phones shall be used. All phones may have embedded antennas. Preferably, at least one phone should have an antenna at the base of the phone and one phone should have an antenna embedded in the back of the phone.

The phones for all bands should be significantly different in size and have antennas located in different locations within the phone. All phones used in the study should be well characterized and known to be stable.

The applied evaluation techniques, the rationale for the selection of phones and frequencies, obtained results and extrapolations for obtaining the required coverage factors shall be documented and made available to the reviewing bodies.

G.10.2 Head Phantom Uncertainty

The head phantom uncertainty is the effect of the tolerances of the inner and outer surface shape, the dielectric parameters and the shell thickness, as well as the supporting materials except the head phantom fixture. The transformations of these tolerances to uncertainties for TRP/NHPRP/UHRP/PGRP have been studied in *The Uncertainties and Repeatability Limitations of Transmitter and Receiver Performance Assessments Posed by Head Phantoms* [3]. The following approximations ([Equation G.25](#) through [Equation G.28](#)) shall be used to determine the head uncertainty for both orientations, i.e., vertical and horizontal orientation, where a rectangular distribution shall be assumed:

EQUATION G.25

$$u_{head_phantom_shell}[dB] = c_1 \cdot \left[10 \cdot \log_{10} \left(1 + \left| \frac{\Delta d}{d} \right| \right) \right]$$

EQUATION G.26

$$u_{head_phantom_permittivity}[dB] = c_2 \cdot \left[10 \cdot \log_{10} \left(1 + \left| \frac{\sqrt{\Delta \epsilon^2 + \Delta \epsilon_{unc}^2}}{\epsilon} \right| \right) \right]$$

EQUATION G.27

$$u_{head_phantom_conductivity}[dB] = c_3 \cdot \left[10 \cdot \log_{10} \left(1 + \left| \frac{\sqrt{\Delta \sigma^2 + \Delta \sigma_{unc}^2}}{\sigma} \right| \right) \right]$$

EQUATION G.28

$$u_{head_phantom_shape}[dB] = c_4 \cdot \left[10 \cdot \log_{10} \left(1 + \left| \frac{\Delta shape}{shape} \right| \right) \right]$$

where

The weighting factor $c_1 = 0.10$ as determined according to [Appendix I](#) and documented in *The Uncertainties and Repeatability Limitations of Transmitter and Receiver Performance Assessments Posed by Head Phantoms* [3]. Δd is the maximum deviation from the nominal shell thickness d (see [Appendix C](#)) from the CAD file, whereas the maximum tolerable deviation is ± 0.2 mm. This tolerance must be verified for an area as wide as ± 50 mm symmetric to the line connecting the Ear Reference Point to the Mouth Point (line extending from the ear reference point to 20 mm below the mouth point as well as for the surface of the ear). The measurements can be conducted with a properly calibrated inductive thickness measurement instrument. The corresponding measurement documentation can be provided by the vendor of the head phantom, which only requires validation if the head phantom has visually degenerated.

$\Delta \epsilon$ and $\Delta \sigma$ are the tolerances from the target relative permittivity and conductivity of the head material, respectively, where the maximum tolerance shall be $\pm 20\%$. Weighting factor $c_2 = 0.39$ and weighting factor $c_3 = 0.065$ were determined according to the methodology of [Appendix I](#) [3].

$\Delta \epsilon_{unc}$ and $\Delta \sigma_{unc}$ are expanded measurement uncertainties ($k = 2$) of dielectric parameters according to [Appendix G.10.6](#).

$\Delta shape$ is the tolerance of the inner surface of the shell. If the tolerance is within 2% from that specified in the SAM CAD file provided in IEEE 1528-2002 [10] and maintained in this boundary range during the entire measurement cycle, the effect of the head phantom shape can be neglected, i.e., weighting factor $c_4 = 0$. If the tolerance is larger, a numerical study as outlined in [Appendix I](#) must be conducted to determine $\Delta shape$.

When the IEEE SAM head phantom is extended below the neck region, as described in [Appendix C.2.1](#), an additional uncertainty of 0.25 dB ($k=2$) shall be added.

G.10.3 Hand Phantom Uncertainty

The hand phantom makes a contribution to OTA measurement uncertainty due to the manufacturing tolerances of its dielectric properties and shape [11]. In this section, the requirements for acceptance of the hands are defined and how the uncertainty of the hands, that meet the minimal requirements, is determined.

The dielectric properties on the surface of the hand may differ from those of its interior, so both are included in the evaluation. The molded exterior surface of the hand shall be measured directly with an open-ended coaxial probe. The interior hand material is evaluated indirectly, by substituting a cube-shaped sample molded from the same material and having some exterior surfaces removed. The full protocol for evaluating the hand phantom material is as follows:

1. Each hand shall be manufactured together with a reference cube of the same material. The sides of the reference cube shall be not less than 40 mm in length.
2. The molded surface on three orthogonal sides of the cube shall be sliced away to a depth of at least 3 mm, in order to expose interior material for evaluation. The remaining three sides of the cube shall be left untreated.

3. Relative permittivity and conductivity shall be measured at ten specified points on the hand exterior surface (see Figure G-1 through Figure G-4), and the exterior averages (\mathcal{E}_{ext_avg} , σ_{ext_avg} , 10 points) and standard deviations (\mathcal{E}_{ext_std} , σ_{ext_std} , 10 points) calculated accordingly. If a non-standard handgrip is used, then select 10 points on the hand exterior surface similar to those shown in Figure G-1 through Figure G-4.
4. Relative permittivity and conductivity shall be measured at ten different points on each of the three cut, exposed surfaces of the reference cube, and the combined interior averages (\mathcal{E}_{int_avg} , σ_{int_avg} , 30 points) and standard deviations (\mathcal{E}_{int_std} , σ_{int_std} , 30 points) shall be calculated. Individual interior averages for each of these three sides (\mathcal{E}_{int_i} , σ_{int_i} , 10 points) shall also be calculated.
5. The total averages (\mathcal{E}_{avg} , σ_{avg}) shall be calculated as the average of exterior and interior values by either evaluating all data points or using:

$$\left(\mathcal{E}_{avg} = \frac{\mathcal{E}_{ext_avg} + 3 \cdot \mathcal{E}_{int_avg}}{4}, \sigma_{avg} = \frac{\sigma_{ext_avg} + 3 \cdot \sigma_{int_avg}}{4} \right)$$

6. The total standard deviations (\mathcal{E}_{std} , σ_{std}) shall be calculated as the statistical combination of exterior and interior values by either evaluating all data points or using:

$$\left(\mathcal{E}_{std} = \sqrt{\frac{1}{4} \left(\mathcal{E}_{ext_std}^2 + \mathcal{E}_{ext_avg}^2 + 3 \cdot \left(\mathcal{E}_{int_std}^2 + \mathcal{E}_{int_avg}^2 \right) \right)} - \mathcal{E}_{avg}^2 \right),$$

$$\sigma_{std} = \sqrt{\frac{1}{4} \left(\sigma_{ext_std}^2 + \sigma_{ext_avg}^2 + 3 \cdot \left(\sigma_{int_std}^2 + \sigma_{int_avg}^2 \right) \right)} - \sigma_{avg}^2 \right)$$

7. The hands are acceptable, i.e., meeting the minimal requirements, if:
 - a. \mathcal{E}_{avg} deviate by less than 15% from the target values
 - b. σ_{avg} deviate by less than 25% from the target values
 - c. the difference between the averaged permittivity of each 10-point interior surface (\mathcal{E}_{int_avg}) deviates by less than 10% and (\mathcal{E}_{ext_avg}) by less than 20% from the total average \mathcal{E}_{avg}
 - d. the difference between the averaged conductivity of each 10-point interior surface (σ_{int_avg}) deviates by less than 20% and (σ_{ext_avg}) by less than 30% from the total average σ_{avg}
 - e. the standard deviation of the combined measurements (30 interior points and 10 exterior points) is less than 20% for permittivity \mathcal{E}_{std} and less than 40% for conductivity σ_{std}
8. For the hands meeting the minimal requirements of step 7., the following approximations (Equation G.29 through Equation G.31) shall be used to determine the hand uncertainty where a rectangular distribution is assumed. The total standard uncertainty (root-sum-squares of $U_{hand_phantom_permittivity}$, $U_{hand_phantom_conductivity}$, $U_{hand_phantom_shape}$) shall not exceed 0.5 dB:

EQUATION G.29

$$u_{hand_phantom_permittivity}[dB] = c_1 \cdot \left[10 \cdot \log_{10} \left(1 + \left| \frac{\sqrt{\Delta \epsilon_{avg}^2 + \epsilon_{unc}^2 + (a_1 \epsilon_{std})^2}}{\epsilon} \right| \right) \right]$$

EQUATION G.30

$$u_{hand_phantom_conductivity}[dB] = c_2 \cdot \left[10 \cdot \log_{10} \left(1 + \left| \frac{\sqrt{\Delta \sigma_{avg}^2 + \sigma_{unc}^2 + (a_1 \sigma_{std})^2}}{\sigma} \right| \right) \right]$$

EQUATION G.31

$$u_{hand_phantom_shape}[dB] = c_3 \cdot \left[10 \cdot \log_{10} \left(1 + \left| \frac{\Delta shape}{shape} \right| \right) \right]$$

whereby,

$\Delta \epsilon_{avg}$, $\Delta \sigma_{avg}$, ϵ_{std} , σ_{std} are the values determined as defined above and ϵ_{unc} and σ_{unc} are expanded measurement uncertainties ($k = 2$) of the dielectric parameters according to [Appendix G.10.6](#) determined for homogeneous materials.

The cube will be provided together with the hand such that the user can evaluate if the interior (cube) properties of the hand has degenerated over time by performing the test above. $c_1 = 0.78$, $c_2 = 0.39$ and $a_1 = 0.50$ were determined according to the methodology of [Appendix I](#). OCP measurements at the surface of used hands may change over time with minimal impact on OTA evaluations due to the sensitivity of the OCP method on surface contamination.

$\Delta shape$ is the uncertainty on TRP/NHPRP/UHRP/PGRP, resulting from the tolerance of the hand phantom shape. Since the hands are usually manufactured within models, the tolerance is 2% and therefore the effect is negligible, i.e., $c_3 = 0$. If the tolerance is larger, a numerical study as outlined in [Appendix I](#) must be conducted to determine $\Delta shape$.

FIGURE G-1 TEN LOCATIONS OF DIELECTRIC MEASUREMENTS AT THE BRICK HAND SURFACE

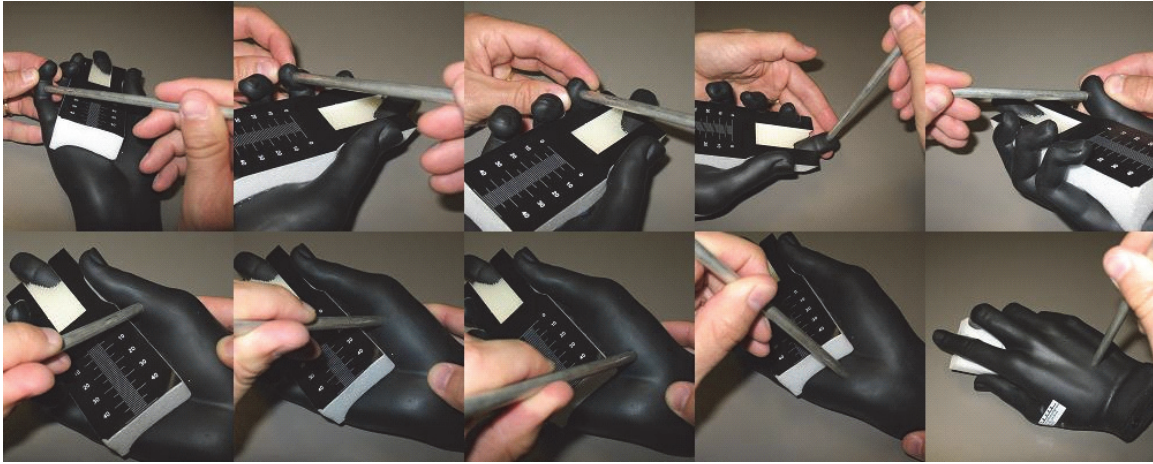

FIGURE G-2 TEN LOCATIONS OF DIELECTRIC MEASUREMENTS AT THE FOLD HAND SURFACE



FIGURE G-3 TEN LOCATIONS OF DIELECTRIC MEASUREMENTS AT THE NARROW DATA HAND SURFACE

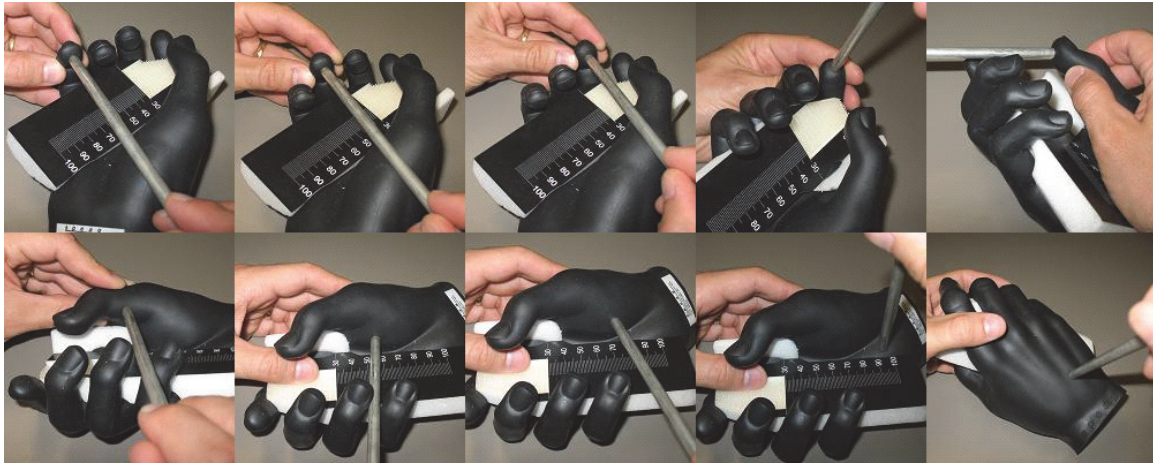

FIGURE G-4 TEN LOCATIONS OF DIELECTRIC MEASUREMENTS AT THE PDA HAND SURFACE

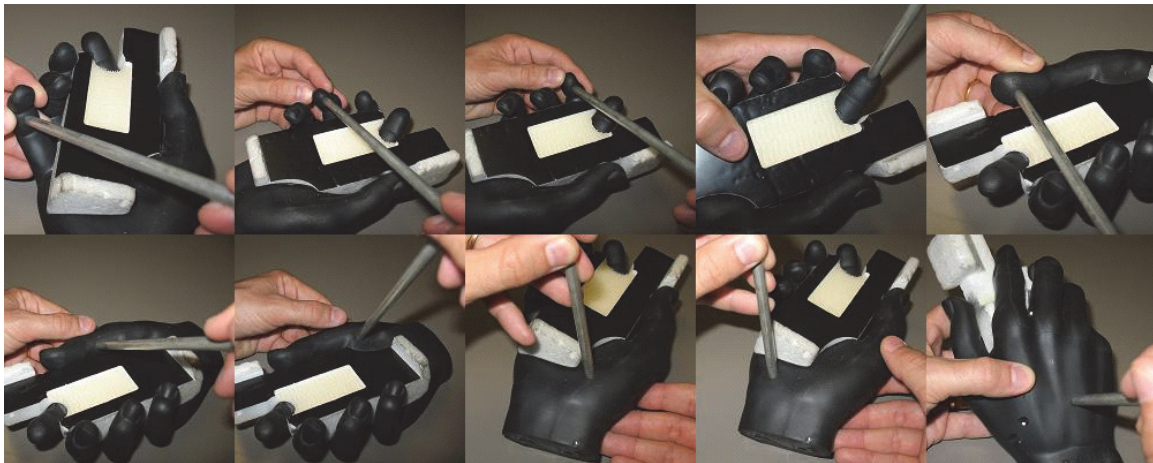
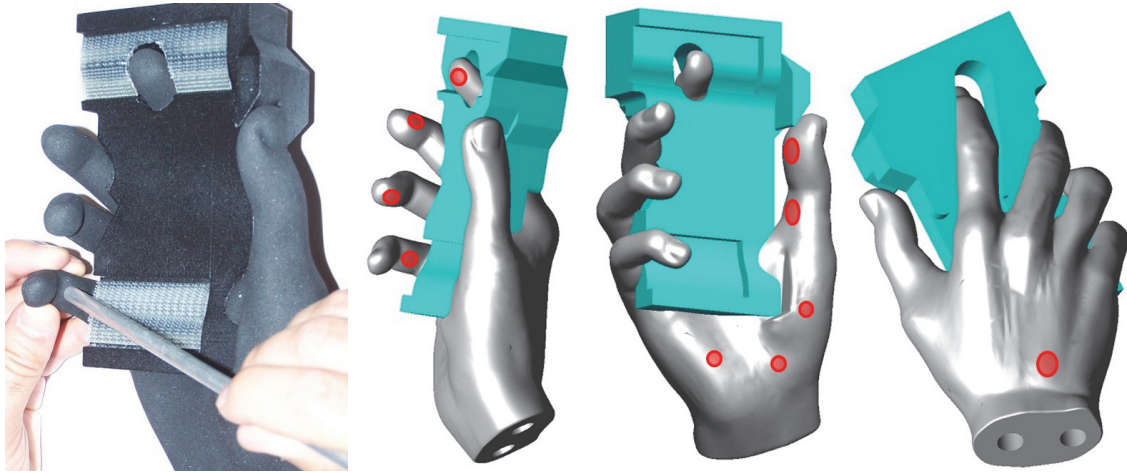

FIGURE G-5 TEN LOCATIONS FOR DIELECTRIC MEASUREMENT OF THE WIDE GRIP HAND SURFACE



G.10.4 Head and Hand Phantom Fixtures Uncertainty

The head and hand phantom fixtures uncertainty is the effect of the head and hand phantom fixtures on the TRP/NHPRP/UHRP/PGRP compared to the standard configuration with an ideally RF transparent fixture. The head phantom fixture is the adapter between the mounting structure or head adapter connected to the turntable and head. The hand fixture is the fixture with which the phone can be appropriately positioned at the head. They shall be constructed with low-loss dielectric material with a dielectric constant of less than 5 and a loss tangent of less than 0.05 for frequencies between 300 MHz-6 GHz and the proof of compliance has to be documented (these material parameters can be determined using the methods described in [Appendix H](#)). Any metallic parts such as screws shall not exceed 10 mm in any dimensions. The head and hand phantom fixtures and the mounting structure can be evaluated combined or separately, as described in [Appendix G.10.4.1](#) and [Appendix G.10.4.2](#). Two methods, an experimental and a numerical technique, are proposed to obtain an uncertainty estimate. If the uncertainties are evaluated individually the combined uncertainty shall be determined by root-sum-squares since the directional distortions can be considered independent. The effect of the fixture is frequency dependent and shall be evaluated (at a minimum) at the middle channel of the 1) 5 GHz 802.11n band (the middle channel will be the channel supported from this list (44, 60, 120, 157, 165) that is closest to 5500 MHz), 2) 3GPP Band 48, 3) 3GPP Band 41 or 3GPP Band 7, 4) PCS band and 5) Cell band in order to estimate the uncertainty of the 5000-6000 MHz, 3300-3800 MHz, 2300-2800 MHz, 1175.45-2200 MHz and the 600-1175.45 MHz bands, respectively.

G.10.4.1 Experimental Evaluation

The following procedure allows evaluation of the RF impact of any additional support structure or fixtures used to hold the hand phantom against the side of the head phantom. Repeated TRP tests with and without the fixtures in place are used to estimate the resulting measurement uncertainty using a Type A analysis.

For the purpose of this test it is necessary to rigidly attach each phone and hand combination to the head in order to evaluate the TRP with and without the supporting fixture in place. This may be accomplished

using a minimum of cellophane tape and expanded polystyrene foam as required to support the phone and hand, while avoiding significant impact on the radiation pattern of the EUT. In order to provide sufficient variation in radiation pattern and near-field coupling effects, the minimum number and type of EUTs, as specified in [Appendix G.10.1](#), shall be used.

The RF evaluation shall be performed at the middle channel of the 1) 5 GHz 802.11n⁸ band (the middle channel will be the channel supported from this list (44, 60, 120, 157, 165) that is closest to 5500 MHz), 2) 3GPP Band 48, 3) 3GPP Band 41 or 3GPP Band 7, 4) PCS band and 5) Cell band in order to estimate the uncertainty of the 5000-6000 MHz, 3300-3800 MHz, 2300-2800 MHz, 1175.45-2200 MHz and the 600-1175.45 MHz bands, respectively.

For each phone, repeat the following steps:

1. Record the phone model, style, description, serial number, and any other identifying information.
2. Set up and verify proper operation of the OTA test system.
3. Mount the phone in the appropriate hand phantom and attach rigidly to the head phantom as described in [Appendix A](#), and place the head/hand/phone combination in the test system.
4. Perform a TRP test at each required channel, repeating the test three times.
5. Install the hand support structure, positioning it in a manner representative of the way it would be oriented in order to hold the hand phantom in its current position, taking care to avoid moving the hand phantom and phone relative to the head phantom.
6. Measure the TRP of the head/hand/phone/fixture combination at each required channel, and repeat the test a total of five times.
7. Remove the hand support structure and repeat the TRP test on the head/hand/phone combination an additional three times.
8. Calculate the TRP and NHPRP values for each measurement as specified in [Appendix B.3](#), as well as the UHRP (Upper Hemisphere Radiated Power) and PGRP (Partial GNSS Radiated Power) corresponding to the UHS and PIGS values.
9. For each test frequency, determine the average and standard deviation of each value across the six head/hand/phone only tests.
10. Subtract the average values from the corresponding values for each of the head/hand/phone/fixture tests and determine the absolute maximum of each value.

Once each phone has been tested in this manner, perform the following analysis to determine the uncertainty estimate for this support fixture.

1. Determine the maximum of each TRP/NHPRP/UHRP/PGRP delta across all phones.
2. Convert each of these values, X_{Max} , to a standard uncertainty assuming a rectangular distribution:

$$(u_{X_{Max,j}} = X_{Max} / \sqrt{3})$$
3. Average the standard deviation of each TRP/NHPRP/UHRP/PGRP across all reference (head/hand/phone only) tests. This value represents the standard uncertainty inherent in the repeatability of the test system.
4. Determine the standard uncertainty of each TRP/NHPRP/UHRP/PGRP value using the following formula:

$$u_{X_j} = \sqrt{u_{X_{Max,j}}^2 - \bar{\sigma}^2}$$

8. The 5 GHz 802.11n band shall be tested according to the *CTIA Certification/Wi-Fi Alliance Test Plan for RF Performance Evaluation of Wi-Fi Mobile Converged Devices*.

In the event that $u_{X_{Max}j}$ is less than the repeatability standard uncertainty, $\bar{\sigma}$, then $u_{Xj}=0$.

5. The maximum u_{Xj} from the TRP/NHPRP/UHRP/PGRP values shall then be used as the standard measurement uncertainty estimate, u_j , for the fixture. If the maximum u_{Xj} , $u_{Xj_{Max}}$, is less than the average of all $\bar{\sigma}$ for the various radiated power quantities at a given frequency, $\bar{\bar{\sigma}}$, (indicating that the effect of the support structure cannot be clearly extracted from the noise of the repeatability) then the required u_j shall be given by the following formula:

$$u_j = \sqrt{\frac{u_{Xj_{Max}}^2 + \bar{\bar{\sigma}}^2}{2}}$$

G.10.4.2 Numerical Evaluation

The study shall be conducted according to [Appendix I](#) by comparing the differences between TRP/NHPRP/UHRP/PGRP with and without fixtures.

G.10.5 Phone Positioning Uncertainty

The phone positioning is the largest phantom related uncertainty and requires careful assessment, especially since it depends on the skills and care of the person conducting the tests. The position of the phone affects the electromagnetic loading with respect to the hand and head, the scattering and absorption properties, orientation with respect to the evaluation plan, etc. The effect of this tolerance on TRP/NHPRP/UHRP/PGRP not only depends on the deviation of the position, but also depends strongly on the phone and frequency. Two methods, an experimental and a numerical technique, are proposed to obtain an uncertainty estimate based on a maximum expected position variation. In order to determine this maximum position variation, the lab must evaluate how their personnel place the EUT on the phantom(s) using any available fixturing, as well as any flexure in their test setup that can cause the position to vary, and then use that maximum positional variation to determine the overall RF impact of the expected variation.

To determine the expected positioning repeatability by the lab technicians a variety of different phone styles, shapes, and sizes shall be evaluated. The minimum number and type of phones, as described in [Appendix G.10.1](#) shall be evaluated.

For each phone, perform the following steps:

1. Instruct each technician to attach the phone to the head and/or hand as directed in [Appendix A](#) using whatever fixturing is to be used regularly. The technician shall not be “coached” to produce the best setup, although prior training to ensure that the technicians are aware of the proper methodology is recommended.
2. For all phone setups, have an independent observer record the position of the phone relative to the available reference marks on the head and/or hand phantom, as well as the position of the hand relative to the head, when applicable. Recorded information should represent both position offsets in h and v directions and the angular rotations r_1 and r_2 ([Figure G-6](#)). It is recommended that a repeatable system of photography (e.g., camera(s) on tripod(s) at unchanged or precisely marked locations relative to the head/hand) be used to photograph each setup to allow overlaying the various photographs to evaluate the range of variation in position/orientation from multiple directions (e.g., top, front, and side).
3. For systems where the head/hand combination rotates around a horizontal axis, such that the effect of gravity on the mounting will change throughout the test, the variation in mounting position shall be evaluated as a function of orientation. In this case, mount the head/hand/

- EUT combination as used and compare the relative positions of the EUT and hand at no less than four positions (every 90 degrees in an above, below, left, right orientation)
4. Repeat steps 1-3 for each technician in the lab, ensuring that each mounting process is started from the same completely disassembled state. For labs with a small number of technicians, the mounting should be repeated multiple times by each technician to produce at least five separate mountings per phone.
 5. Repeat steps 1-4 for all technicians.
 6. For each phone, determine the maximum deviation from the target reference points described in [Appendix A](#) and treat it as a rectangular quantity for each measured dimension h , v , r_1 and r_2 . If the sample size is sufficiently large and it has been shown that the distribution is normal, then the standard deviation can be assessed and used in the following evaluation of [Appendix G.10.5.2](#).

In the case where the RF evaluation will be performed on equivalent phone models to those evaluated here, the corresponding variation quantities for each phone model may be used. Otherwise, the maximum variation across all evaluated phone models shall be used for the RF uncertainty evaluation. It is recommended that this procedure is repeated whenever a technician is added to the team.

For relative measurements, if the phone is not handled between measuring both test configurations, then the additional uncertainty due to the positioning error of the EUT with the head/hand phantom will be 0.00 dB for this measurement. Otherwise, this uncertainty should be included twice, once in the reference TRP/TIS measurement, and once in the relative measurement.

G.10.5.1 Experimental Evaluation

The following procedure allows evaluation of the RF impact of the expected positioning uncertainty based on the analysis performed above. Repeated TRP tests with intentional deviations matching those found in the previous analysis shall be used, using any corresponding fixturing, etc. In order to provide sufficient variation in radiation pattern and near-field coupling effects, the minimum number and types of EUTs, as described in [Appendix G.10.1](#), shall be used.

The RF evaluation shall be performed at the middle channel of the 1) 5 GHz 802.11n⁹ band (the middle channel will be the channel supported from this list (44, 60, 120, 157, 165) that is closest to 5500 MHz), 2) 3GPP Band 48, 3) 3GPP Band 41 or 3GPP Band 7, 4) PCS band and 5) Cell band in order to estimate the uncertainty of the 5000-6000 MHz, 3300-3800 MHz, 2300-2800 MHz, 1175.45-2200 MHz and the 600-1175.45 MHz bands, respectively.

For each phone, repeat the following steps:

1. Record the phone model, style, description, serial number, and any other identifying information.
2. Set up and verify proper operation of the OTA test system.
3. Mount the phone in the appropriate hand phantom and attach to the head phantom as described in [Appendix A](#), offsetting the phone from the target position by the maximum offsets as determined according to [Appendix G.10.5](#) step 6.
4. Place the head/hand/phone combination in the test system and measure the TRP at each required channel.

9. The 5 GHz 802.11n band shall be tested according to the *CTIA Certification/Wi-Fi Alliance Test Plan for RF Performance Evaluation of Wi-Fi Mobile Converged Devices*.

5. Choose the maximum deviation dimension and adjust the phone/hand combination so that it is offset in the opposite direction (reverse the sign of the deviation) and repeat step 4.
6. Choose the next largest deviation and repeat the adjustment for that dimension and repeat step 4.
7. Flip the sign on the first deviation again to put that offset back to its starting position and repeat step 4. At this point, four cardinal positions with the maximum deviation shall have been tested.
8. Continue swapping the sign of the remaining deviation quantities, adjusting the position of the phone, and remeasuring the TRP until no less than six distinctly different positions with the maximum position variation have been evaluated.
9. Calculate the TRP and NHPRP values for each measurement as specified in [Appendix B.3](#), as well as the UHRP and PGRP corresponding to the UHIS and PIGS values.
10. For each test frequency, determine the maximum delta in dB of each value across the six (or more) head/hand/phone tests.
Once each phone has been tested in this manner, perform the following analysis to determine the uncertainty estimate for the positioning repeatability.
11. For each test frequency, determine the maximum of each TRP/NHPRP/UHRP/PGRP delta in dB across all phones and calculate the standard uncertainty (k=1) due to positioning error using the following formula:

$$u_{\text{positioning}}[dB] = \frac{u_{\text{positioning_max}}[dB]}{2\sqrt{3}}$$

G.10.5.2 Numerical Evaluation

Alternatively, a Type A uncertainty analysis can be conducted using high-end simulation tools supporting scripting of mechanical positioning. A similar procedure, as described in [Appendix G.10.5.1](#), was performed with all OTA measurements replaced with simulation results. A mechanical position matrix is derived for which the analysis is conducted following the procedures described in [Appendix I](#).

The following approximation ([Equation G.32](#)) shall be used to determine the phone positioning uncertainty:

EQUATION G.32

$$u_{\text{positioning}}[dB] = \sqrt{(k_1 \cdot |h|)^2 + (k_2 \cdot |v|)^2 + (k_3 \cdot |r_1|)^2 + (k_4 \cdot |r_2|)^2}$$

where:

h is the horizontal deviation (see [Figure G-6](#)) in mm from the exact position described in [Appendix A](#) and must be determined according to the procedure defined below.

v is the vertical deviation (see [Figure G-6](#)) in mm from the exact position described in [Appendix A](#) and must be determined according to the procedure defined below.

r_1 and r_2 are angular deviations (see [Figure G-6](#)) in degrees from the exact position described in [Appendix A](#) and must be determined according to the procedure defined below.

$k_1 = 0.18$, $k_2 = 0.07$, $k_3 = 0.14$ and $k_4 = 0.44$ are the sensitivity factors which were determined according to the methodology of [Appendix I](#). The maximum sensitivity has been expanded by the number of degrees of freedom. If the maximum deviations for h , v , r_1 and r_2 are determined according to [Appendix G.10.5](#) step 6, then a rectangular distribution (divisor = 1.73) shall be used. If h , v , r_1 and r_2 are determined as standard deviations assuming a normal distribution. In this case, the standard deviation shall be treated as a standard uncertainty (divisor = 1) shall be used in [Table G-4](#). These equations are only valid for h and $v \leq 5$ mm and r_1 and $r_2 \leq 2$ degrees.

FIGURE G-6 PHONE POSITIONING UNCERTAINTY COMPONENTS

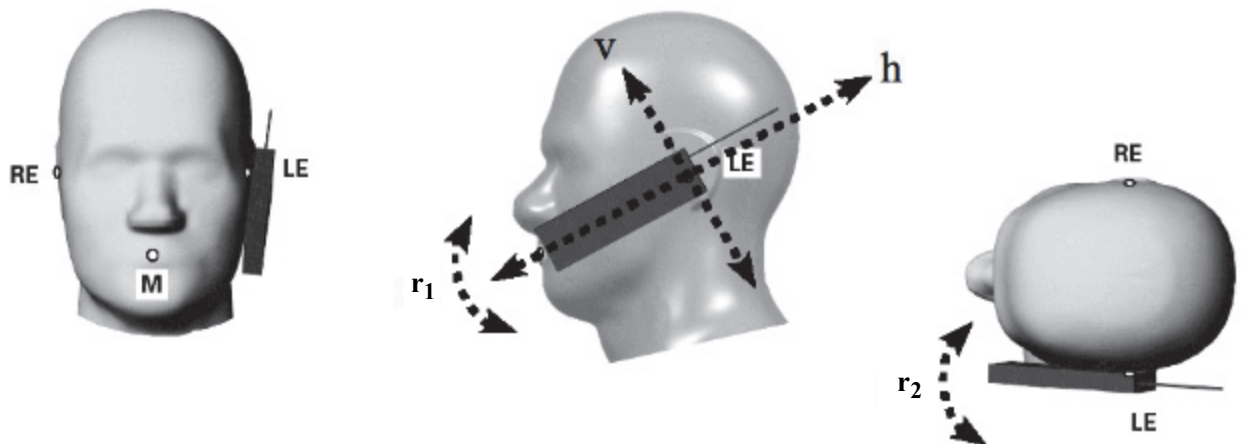

G.10.6 Estimation of Dielectric Parameter Measurement Uncertainties

The measurement procedures described in [Appendix G](#) use vector network analyzers for dielectric property measurements. Network analyzers require calibration in order to account for and remove inherent losses and reflections. The uncertainty budget for dielectric measurement contains inaccuracies in the calibration data, analyzer drift, and random errors. Other sources of errors are the tolerances on the sample holder hardware, and deviations from the optimal dimensions for the specified frequencies, and sample properties and dimensions. This applies regardless of the type of sample holder and the nature of the scattering parameters being measured.

An example uncertainty template is shown in [Table G-3](#). Influence quantities shown may or may not apply to a specific test set-up or procedure, and other components not listed may be relevant in some test set-ups. The contributions also depend on the frequency and the type of sample (liquid, gel or solid). Measurement of well-characterized reference materials can be used to estimate the dielectric property measurement uncertainty, as described in the following procedure.

Note: Due to the inability to assess the measurement uncertainty of the solid tissue equivalent material for the head phantom, the use of solid head phantoms is not allowed in the test plan at this time.

1. Configure and calibrate the network analyzer in a frequency span large enough for the frequency range of interest, for example from 300 MHz to 3 GHz in 5 MHz steps, or with five or more frequencies within the device transmission band.
2. Measure a reference material at least n times to obtain the average and standard deviation for the relative permittivity and conductivity at each device centre-band and nearby frequencies.

- For each of the test runs from step 2, to verify calibration validity versus frequency, calculate the differences between the measured and corresponding reference data at five or more frequencies within the device transmission band using the equations.

$$\epsilon'_{r \text{ tolerance}} [\%] = 100 \times \left| \frac{\epsilon'_{r \text{ measured}} - \epsilon'_{r \text{ ref}}}{\epsilon'_{r \text{ ref}}} \right|$$

$$\sigma_{\text{ tolerance}} [\%] = 100 \times \left| \frac{\sigma_{\text{ measured}} - \sigma_{\text{ ref}}}{\sigma_{\text{ ref}}} \right|$$

- Use predetermined standard deviations for permittivity and conductivity if available. Otherwise, calculate the standard deviation of the mean (s/\sqrt{n}), e.g., *NIS 81* [12], using the maximum value versus frequency for the n separate permittivity and conductivity tolerances of step 3.
- Estimate the uncertainties for the other components of [Table G-3](#) (and other relevant components if needed) in the frequency range under consideration.
- The individual uncertainties for ϵ'_r and σ each are entered into the columns a , b , c of [Table G-3](#) to calculate the standard uncertainties u_i and the combined standard uncertainty. Insert a completed version of [Table G-3](#) into the test report, along with rationale for which influence quantities were used or omitted.
- Measure a second reference material to verify relative calibration validity, and ascertain that the measured data agrees with the reference values as in step 3. If equipment drift is suspected, go back to the reference material tests of step 2.

TABLE G-3 EXAMPLE OF UNCERTAINTY TEMPLATE FOR DIELECTRIC CONSTANT (ϵ'_R) OR CONDUCTIVITY (σ) MEASUREMENT AT A SPECIFIC FREQUENCY BAND¹

Uncertainty Component	Tolerance/ Uncertainty Value (± %)	Probability Distribution	Divisor	c_i	Standard Uncertainty (± %)	v_i or v_{eff}
	a		b	c	$u_i = (a/b) \times (c)$	
Repeatability (n repeats, mid-band)		Normal	1^2	1		$n-1$
Reference material ϵ'_r or σ		Rectangular	$\sqrt{3}$	1		∞
Network analyzer drift, linearity, etc.		Rectangular	$\sqrt{3}$	1		∞
Test-port cable variations		U-shaped	$\sqrt{2}$	1		∞
Dimensional accuracy of the sample / line		Normal	1^2	1		∞
Homogeneity of the material		Normal	1^2	1		∞

TABLE G-3 EXAMPLE OF UNCERTAINTY TEMPLATE FOR DIELECTRIC CONSTANT (ϵ_R') OR CONDUCTIVITY (s) MEASUREMENT AT A SPECIFIC FREQUENCY BAND¹

Uncertainty Component	Tolerance/ Uncertainty Value (± %)	Probability Distribution	Divisor	c_i	Standard Uncertainty (± %)	v_i or v_{eff}
	a		b	c	$u_i = (a/b) \times (c)$	
Temperature of the material		Rectangular	$\sqrt{3}$	1		∞
Combined standard uncertainty						
Expanded uncertainty $k = 2$						
Note 1: Column headings a , b , c are given for reference. Separate tables are usually needed for each ϵ_r' and s . Note 2: Assumes the uncertainty value in column a is the standard deviation of a normal distribution. For an expanded uncertainty of a normal distribution, divide by 2.						

Uncertainty contributions

Repeatability: Refer to evaluation of step 4) above.

Reference material: Uncertainty of the available reference data.

Network analyzer: Drift, Linearity and other contributions affecting the capability to measure attenuation and phase at the specific frequency.

Test-port cable variations: Influence of cable variations on amplitude and phase measurement

Dimensional accuracy of the sample/line: The reference line is assumed to be an precision 50 Ohm line with a section of air dielectric. With the section of this line filled with the sample material must be well known in length, not change the dimensions of the line, and fill the space without gaps at the inner or outer conductor.

Homogeneity of the material: Inhomogeneities of the material composition or inclusion of air affects the measurement. S21 or S12 should not differ significantly.

Temperature of the material: Influence of changes of the dielectric properties of the sample or reference material with the temperature, as far as not compensated.

Alternative method for evaluating uncertainties can be found in *Dielectric Metrology with Coaxial Sensors* [13].

G.10.7 Uncertainty for Reasonably Worst-case Head, Hand and EUT Positioning in the Hand and against the Head

The uncertainty for reasonably worst-case head, hand and EUT positioning in the hand and against the head are provided in [Table G-4](#).

TABLE G-4 EXAMPLE OF UNCERTAINTY ASSESSMENT FOR REASONABLY WORST-CASE HEAD, HAND AND EUT POSITIONING IN THE HAND AND AGAINST THE HEAD

Uncertainty Component	Tolerance/ Uncertainty Value (± dB)	Probability Distribution	Divisor	c_i	Standard Uncertainty (± dB)	v_i or v_{eff}
	a		b	c	$u_i = (a/b) \times (c)$	
Head Phantom						
Shell Thickness	0.41	Rectangular	1.73	0.10	0.02	∞
Filling/Liquid Dielectric Constant	0.46	Rectangular	1.73	0.39	0.10	∞
Filling/Liquid Conductivity	0.81	Rectangular	1.73	0.065	0.03	∞
Geometry/Shape	1.00	Rectangular	1.73	0.00	0.00	∞
Supporting Structure Uncertainty		Rectangular				
Combined Head Phantom Uncertainty					0.11	
Hand Phantom						
Material Dielectric Constant	0.59	Rectangular	1.73	0.78	0.26	
Material Conductivity	1.10	Rectangular	1.73	0.39	0.25	
Geometry/Shape (incl. spacer)	1.00	Rectangular	1.73	0.00	0.00	
Combined Hand Phantom Uncertainty					0.36	
Fixtures						
Head Phantom Fixture	0.25	Rectangular	1.73	1.00	0.14	
Hand Phantom Fixture	0.40	Rectangular	1.73	1.00	0.23	
Data Mode Fixture	0.16	Rectangular	1.73	1.00	0.09	
EUT Related						
EUT Positioning	0.58	Rectangular	1.73	1.00	0.33	
Combined Standard Uncertainty (Head+Hand+Fixture)					0.57	
Combined Standard Uncertainty (Hand+Fixture)					0.37	

Head Phantom				
	Δd	d	a	
Shell Thickness Uncertainty Component	0.2	2	0.41	Reference Equation G.25
	$\Delta \epsilon / \epsilon$	$\Delta \epsilon_{unc} / \epsilon$	a	
Filling/Liquid Dielectric Constant	0.1	0.05	0.46	Reference Equation G.26
	$\Delta \sigma / \sigma$	$\Delta \sigma_{unc} / \sigma$	a	
Filling/Liquid Conductivity	0.2	0.05	0.81	Reference Equation G.27

Hand Phantom						
	$\Delta \epsilon_{avg} / \epsilon$	$\epsilon_{unc} / \epsilon$	$\epsilon_{std} / \epsilon$	a_1	a	
Material Dielectric Constant	0.1	0.03	0.2	0.5	0.59	Reference Equation G.29
	$\Delta \sigma_{avg} / \sigma$	σ_{unc} / σ	σ_{std} / σ	a_1	a	
Material Conductivity	0.2	0.05	0.4	0.5	1.10	Reference Equation G.30

EUT Related						
	h (mm)	v (mm)	r_1 (deg)	r_2 (deg)	a	
EUT Positioning	2.5	2	2	0.5	0.58	Reference Equation G.32

G.10.8 Uncertainties of Hand Phantom Fixture and Phone Positioning in Data Mode Testing

The hand phantom uncertainty shall be evaluated according to [Appendix G.10.3](#). The hand phantom data mode fixture uncertainty shall be evaluated according to [Appendix G.10.4](#). If the uncertainty of positioning of the phone inside the hand is less than ± 1 mm, then this uncertainty is negligible. Otherwise, it shall be evaluated according to [Appendix G.10.5](#). Phone (including hand phantom) positioning uncertainty is performed according to [Appendix G.21](#).

TABLE G-5 EXAMPLE OF UNCERTAINTY ASSESSMENT FOR HAND PHANTOM, FIXTURE AND PHONE POSITIONING IN DATA MODE TESTING

Uncertainty Component	Tolerance/ Uncertainty Value (± dB)	Probability Distribution	Divisor	c_i	Standard Uncertainty (± dB)	v_i or v_{eff}
	a		b	c	$u_i = (a/b) \times (c)$	
Hand Phantom						
Material Dielectric Constant		Rectangular	$\sqrt{3}$			∞
Material Conductivity		Rectangular	$\sqrt{3}$			∞
Geometry/Shape (incl. spacer)		Rectangular	$\sqrt{3}$			∞
Fixture						
Hand Phantom Fixture		Rectangular	$\sqrt{3}$			∞
EUT Related						
EUT Positioning inside Hand Phantom	0	Rectangular	$\sqrt{3}$			∞
EUT (including Hand Phantom) Positioning		Rectangular	$\sqrt{3}$			∞
Combined standard uncertainty						

G.11 Sensitivity Search Step Size

Rather than adjusting the output power of the base station simulator until the digital error rate (BER or FER) is within some narrow percentage range of the target error rate, the test plan requires reporting the power level nearest the target sensitivity level that still results in a passing error rate. This means that, excluding other uncertainty contributions, the actual sensitivity level ranges from the reported level to one step below the reported level. This can be represented as an asymmetric uncertainty contribution of +0/-step size, with a rectangular distribution. However, on average, the actual sensitivity, and thus the resulting TIS, will be one-half step below the reported value. The asymmetric uncertainty can typically be converted to a symmetrical uncertainty by applying an offset to the corresponding measurement value and dividing the total range of the expanded uncertainty by two. However, there are other minor uncertainty contributions related to the stability of the digital error rate measurement that this uncertainty contribution is assumed to encompass. The intention of the TIS test is to report a TIS value that has a high probability of being at or above the target sensitivity level. Therefore, for the purposes of this test plan, this uncertainty contribution is assumed to be symmetrical about the TIS result with a fixed uncertainty contribution of ± one-half of the step size.

For a 0.5 dB step size, a fixed uncertainty contribution of ± 0.25 dB with a rectangular distribution (standard uncertainty contribution of 0.144 dB) should be reported for the step size uncertainty.

G.12 Coarse Sampling Grid in TIS Measurements

The sampling grid for TIS measurements is 30 degree steps in both θ - and ϕ -axes. The uncertainty arises from an assessment of how different the results for this spacing would be from an infinitely small sampling grid. It is possible to argue that, since all test houses are required to measure at the same 30 degree grid points using the same coordinate axes, all results would have the same value of uncertainty. However, this is not an adequate assessment since some carriers will be basing acceptance of handsets on the assumption that the measured values are correct; we need therefore to include, as an uncertainty, the contribution of this effect.

A fixed value of 0.4 dB shall be taken and its distribution shall be assumed to be rectangular (i.e. standard uncertainty = 0.23 dB).

Note: *The 15° sampling grid used in TRP tests is assumed to produce negligible uncertainty.*

G.13 Miscellaneous Uncertainty

In this test plan, the term 'miscellaneous uncertainty' is used to encompass all the unknown, unquantifiable, etc. uncertainties associated with TRP/TIS measurements. This term includes truly random effects as well as systematic uncertainties, such as that arising from dissimilarity between the patterns of the reference antenna and the EUT.

By allowing the inclusion of systematic contributions into the Miscellaneous Uncertainty, repeated measurements are therefore disqualified as a way of enumerating its overall magnitude. As a result, the magnitude of the uncertainty has to be estimated since, at least, the systematic behavior of the pattern difference effect is unquantifiable.

In this test plan, Miscellaneous Uncertainty includes, but is not limited to, the following effects:

- Pattern difference effect
- Humidity effects
- Temperature effects (not so much on equipment or the EUT - more on the losses of cables, attenuators, etc.)
- Personnel
- Dirty connector interfaces

The contribution of this effect to the overall uncertainty budget shall be accounted for in the following way:

- A fixed value of 0.2 dB with a normal distribution (i.e. standard uncertainty = 0.1 dB) shall be taken and incorporated into every uncertainty budget

G.14 TIS Normalization Uncertainty

This uncertainty component arises when using the single point or multi-point alternate test method for TIS testing as described in [Section 6.15.1](#) and [Section 6.15.2](#).

Using the nomenclature of [Section 6.15.1](#), test configuration A will be the protocol/error rate/data rate for which a full TIS measurement is performed while test configuration B will be the target protocol/error rate/data rate which will be tested using the single/multi-point radiated test.

The normalization uncertainty shall be treated as follows.

1. Calculate the standard uncertainty associated with the test configuration A measurement (as used for the full TIS measurement) by dividing half of the step size by $\sqrt{3}$ and by the square root of the number of measurements at different spatial positions which are averaged.

$$u_{j A} = \frac{\text{Step Size}_A}{2\sqrt{3} * \text{Number of Measurements}}$$

2. Calculate the standard uncertainty associated with the test configuration B measurement (a single or multi-point measurement) by dividing half of the step size by $\sqrt{3}$ and by the square root of the number of measurements at different spatial positions which are averaged.

$$u_{j B} = \frac{\text{Step Size}_B}{2\sqrt{3} * \text{Number of Measurements}}$$

3. Combine both of the uncertainty quantities with the other uncertainty contributions by root-sum-squares.

G.15 Effect of Theta Dependent Phi Optimization on TIS

It has been proven elsewhere that the numerical effect of the theta dependent phi optimization on the resultant pattern is negligible. However, for TIS, the reduction in the number of EIS points that are averaged into the resultant TIS can have an impact on the resulting TIS value. The current uncertainty budget does not independently isolate the random error of a single EIS measurement, so for the purpose of this discussion we will assume that the average of that random error is encapsulated in the Sensitivity Search Step Size uncertainty term defined in [Appendix G.11](#).

In general, the average of N repeat measurements containing a random uncertainty term, u_c , will reduce the corresponding random uncertainty by a factor of $1/\sqrt{N}$. Thus, reducing the number of data points for a given cut from N to M will **increase** the random uncertainty of that cut by the factor of $\sqrt{N/M}$. However, since each cut is weighted by the $\sin(\theta)$ term, the corresponding error contribution from that cut in the resulting TIS is also reduced by the same amount in linear units.

Rather than attempting to account for the $\sin(\theta)$ weighting of each curve, the assumption here will be that the total step size uncertainty increases by a factor of $\sqrt{N/M}$ where $N=62$ for an evenly spaced 30 degree step TIS test, and $M=46$ for the theta dependent phi optimized pattern. In this case, $\sqrt{N/M}=1.16$, so that for a 0.5 dB step size, the fixed uncertainty contribution of ± 0.25 dB for the step size uncertainty becomes ± 0.29 dB with a rectangular distribution. Therefore a standard uncertainty contribution of 0.167 dB shall be reported for the step size uncertainty instead of 0.144 dB when the theta dependent phi optimization is used.

G.16 Linearization of RSS Measurements

This uncertainty component arises from linearizing the conducted or radiated RSS measurements. The uncertainty is defined as the maximum standard deviation of the raw conducted or radiated RSS data from the final normalized conducted or radiated RSS data.

It is the responsibility of the lab to measure the maximum standard deviation and this will need to be converted to dB, if necessary.

G.17 Uncertainty of RSS Data from EUT

This uncertainty component refers to the integrity of the data reported, or recorded, by the EUT.

- The RSS measurements reported by the EUT shall be verified by examining the variance of the data in real time to ensure that it is not skewed by an erroneous reading. This variance check shall be used to determine if a data point requires retesting.
OR
- The RSS measurements recorded by the EUT shall be verified using a post processing variance check to ensure that the data is not skewed by an erroneous reading. This variance check shall be used to determine if a data point requires retesting.

It is the responsibility of the lab to determine the maximum variance of the data obtained from the EUT and this will need to be converted to dB, if necessary.

Note: This uncertainty term may be combined with the [Appendix G.16](#) uncertainty term and reported as one uncertainty term.

G.18 Reporting Mechanism for RSS Data from EUT

When the EUT either reports, or records, the RSS data at each position on the 3-D measurement sphere, there is an uncertainty introduced by this reporting mechanism that is inherent to the EUT. This uncertainty contribution refers to the quantization error present in the RSS data reported, or recorded, by the EUT at each data point on the 3-D measurement sphere.

It is the responsibility of the lab to determine the maximum quantization error of the data obtained from the EUT and this will need to be converted to dB, if necessary. This uncertainty term shall be assumed to be rectangularly distributed, in which case the standard uncertainty shall be calculated as $\frac{\text{maximum value}}{\sqrt{3}}$.

G.19 Special Considerations for Notebooks

G.19.1 Measurement Distance

Only notebooks whose single largest dimension is less than or equal to 42 cm shall be tested. Range lengths equal to or greater than the minimum range lengths specified in [Section 3.1](#) of the test plan shall be used.

If the single largest dimension of the notebook computer under test exceeds 30 cm, an additional measurement uncertainty contribution must be included in the measurement uncertainty budget. The additional contribution is shown in [Table G-6](#) below. The values for the additional uncertainty contributions were determined from numerical simulations assuming the worst case scenario of a large notebook with the antenna located in the top corner of the screen.

TABLE G-6 ADDITIONAL MEASUREMENT UNCERTAINTIES FOR LARGE FORM FACTOR DEVICES

Frequency Range	Additional Uncertainty Contribution Required for Measurement Distance between the Minimum Measurement Distance in Table 3-1 and 356 cm
617-1186.68 MHz	0.25 dB
1574-2360 MHz	0.20 dB
2496-5925 MHz	No impact on integrated measurements.

Note: The rationale for the additional uncertainty contributions of [Table G-6](#) is the following: R is less than $2D^2/\lambda$ and $3D$. The MU contribution is based on worst-case simulations, only small impact on integrated measurements is foreseen.

Note: Please refer to [Table 3-2](#) for derivation of Measurement Distance lower bound.

G.19.2 Offset of the Phase Center of the EUT from the Center of Rotation

In many cases the location of an embedded antenna in a notebook computer will be unknown by the lab performing the tests. Hence it will be impossible to place the phase center of the EUT on the axis of rotation. The antenna radiation patterns will be affected by the change in free space dispersion as the phase center moves towards and away from the measurement antenna. The maximum effect of this phenomena is given by:

$$\Delta = 20 \log_{10} \left(\frac{d+l}{d-l} \right) \text{dB}$$

where d is the range length and l is one half of the largest single dimension of the EUT and Δ is the maximum change in the pattern level due to effect. For a range length of 120 cm and a notebook computer with a single largest dimension of 42 cm, this results in a change in received signal level of 3.07dB. However, when the individual measurement points are integrated into a value for TRP or TIS, this effect is greatly reduced. For every point on the front of the measurement sphere where the measured signal level is higher than it should be, there is a corresponding point on the rear of the measurement sphere where the signal level is lower than it should be.

The uncertainty contribution for this effect is included in the uncertainty contribution for measurement distance given in [Appendix G.19.1](#) above and no additional uncertainty contribution is required.

G.19.3 VSWR

Notebooks present large, flat surfaces to the measurement antenna. The material of these surfaces is undefined. Thus there is the possibility that much of the energy incident on the EUT will be reflected back to the measurement antenna. [Appendix G.7.3.1](#) details the procedure for determining the uncertainty contribution due to the change in the input impedance/VSWR of the measurement antenna. This procedure is appropriate for any EUT and no change is required for a notebook computer.

G.19.4 Chamber Standing Wave

As described in [Appendix G.19.3](#) above, notebooks have the potential of setting up large standing waves between the measurement antenna and the EUT. These standing waves contribute to measurement uncertainty in much the same way as reflections from the chamber surfaces and positioning equipment. However, measurements have shown that even with a notebook computer and a short measurement distance, this effect causes a change in measured TRP of less than 0.1 dB. As a result no additional uncertainty contribution is required.

G.19.5 Phase Curvature Across the EUT

The effect of phase curvature across the EUT on the integrated measurements of TRP and TIS is very small. Although the EUT may be relatively large, the actual antenna is small, and the phase curvature across the actual antenna will be insignificant. As a result no additional uncertainty is required beyond that detailed in [Appendix G.19.1](#) above.

G.19.6 Signal Level Ripple within the Quiet Zone

For notebooks whose single largest dimension does not exceed 30 cm, the results of the standard ripple test measurements may be used to calculate the uncertainty contribution due to ripple.

For notebooks whose single largest dimension exceeds 30 cm, the ripple test measurements must be repeated using offsets as described in [Section 3.6](#). The calculation of the measurement uncertainty contribution is then performed as described in [Appendix G.8](#).

G.20 Uncertainty due to Difference in Gain over Different Channel Bandwidths

For relative measurements of different protocols with different channel bandwidths, there may be a difference in the associated path loss.

A conservative way of assessing the uncertainty due to the difference in system path loss over the different channel bandwidths is to perform the following steps:

1. Estimate the system path loss as a function of frequency by applying an appropriate curve fit to the measured system path loss.

2. Calculate the average system path loss over each channel bandwidth.

$$\overline{PL}(a,b) = \frac{1}{b-a} \int_a^b PL(f) df$$

$\overline{PL}(a,b)$ = average path loss over the frequency interval a to b .

$PL(f)$ = path loss as a function of frequency

3. The measurement uncertainty is then the difference in average system path loss over the 2 different channel bandwidths.

For systems with path loss variation less than 3 dB over a 25 MHz band containing the channel bandwidths of interest, a fixed uncertainty contribution of 0.2 dB with a rectangular distribution (standard uncertainty of 0.115 dB) may be used.

G.21 EUT Positioning/Repositioning Uncertainty

There are a number of uncertainty contributions related to positioning or repositioning the EUT in the test environment, including near field effects related to positioning against the head and/or hand phantoms or other fixturing. [Appendix G.10.5](#) details the steps for determining the uncertainty contribution related to near field positioning repeatability with head and hand phantoms. In addition, free-space testing and multi-step test processes such as RSS based TIS and the various alternate test methods require one or more positioning uncertainty contribution(s).

For free-space testing, the orientation of the EUT in the mounting fixture can have small effects on the overall TRP/TIS and near horizon numbers due to slight differences in alignment. In addition, any near field interactions with the dielectric support can have an effect. Repeated TRP tests of a sample device with minor mounting changes between each test can be used to estimate this effect.

For RSS and alternate methods that rely on single point normalization techniques, any difference in the position between reference and target measurements can change the relative results and produces a repositioning error that may just be the result of automated positioning. Since this is a pattern related result instead of an average result like TRP/TIS, the variation at the peak of the EUT pattern can be used to estimate this quantity. For the purposes of this contribution, interpolated TRP pattern data can be used to determine the maximum change expected due to a one-degree positioning change. This term shall be treated as a rectangular distribution.

In cases where the EUT is repositioned relative to the head/hand/fixture (e.g., due to lost call or battery change) between steps of a relative test, the appropriate positioning uncertainty shall be applied a second time as a repositioning uncertainty.

G.22 Test System Frequency Flatness Uncertainty

For wireless technologies with channel bandwidths more than 2 MHz, there is a likelihood that the test system used will not have a flat frequency response across the entire channel. While the range calibration corrects for any variation of frequency response as a function of the center frequency of the channel, the broadband power measured from one of these technologies will be a function of the entire channel bandwidth as opposed to just the center frequency. Thus, any deviation of the rest of the channel from the signal level at the center frequency will result in an error in the measured result. For average power measurements, the error may be measured and corrected for, thereby minimizing the

impact on measurement uncertainty. Where error correction is not possible or practical, the lab shall account for the total measurement uncertainty due to channel frequency response variation. Even with average channel power error correction, there may still be small uncertainty contributions related to frequency interpolation error that may need to be addressed. In addition, sensitivity measurement results are not necessarily a linear function of average channel power, resulting in some additional measurement uncertainty bias.

To determine the appropriate error correction or measurement uncertainty for total channel power, use range calibration curves measured with a frequency resolution sufficient to produce smoothly varying frequency response curves with no evidence of higher order contributions. While resolutions on the order of 1 MHz are likely to be sufficient for most systems, resolutions closer to the channel or RB allocation resolution (e.g. ~200 kHz) are recommended to minimize interpolation error. After applying the reference antenna gain, convert the path loss data to linear power units then perform a running average across the band, averaging the data points across the corresponding channel bandwidth. The following equation describes the expected error contribution that this uncertainty must address:

EQUATION G.33

$$\varepsilon_j = 10 \log \left(\frac{\sum_{k=j-N/2}^{j+N/2} PL_k}{(N+1)PL_j} \right)$$

where ε_j is the expected relative error in the average power result for a given channel in dB, PL_j is the linear path loss at the center frequency of the given channel, PL_k is the linear path loss at each frequency point across the corresponding channel, and N is the number of frequency steps across a given channel bandwidth. Note that $N + 1$ points are actually averaged together from one edge of the channel to the other. This error may be removed directly at each frequency, f_j , by using the average path loss across the channel as the range loss correction rather than the path loss at the center frequency:

EQUATION G.34

$$\overline{PL}_j (dB) = 10 \log \left(\frac{1}{N+1} \sum_{k=j-N/2}^{j+N/2} PL_k \right)$$

If not correcting for the average power error, the maximum deviation across all of the possible channels in a band shall be used to estimate the required channel flatness uncertainty contribution using a rectangular distribution so that $u_i = a_i / \sqrt{3}$, where a_i is given by $a_i = \max(|\varepsilon_j|)$.

Assuming the frequency response is not under-sampled, the worst case error due to interpolation may be estimated as the maximum change in path loss magnitude between any two points within a band.

EQUATION G.35

$$\varepsilon_{interpolation} (dB) = \max(|PL_{j+1} (dB) - PL_j (dB)|)$$

This error shall be converted to an appropriate measurement uncertainty contribution using a rectangular distribution so that $u_i = \varepsilon_{interpolation} / \sqrt{3}$.

Note that while sensitivity results may be more directly affected by the frequency dependent behavior of variations in channel flatness, such that the sensitivity result would be biased to a higher power level (worse sensitivity result), for the purposes of this test plan, this effect is deemed to be encompassed by the sensitivity search step size contribution in [Appendix G.11](#).

G.23 Effect of a Reduction in the Number of Test Samples on TIS Measurements

It has been proven elsewhere that the numerical effect of the theta dependent phi optimization on the resultant pattern is negligible. However, for TIS, the reduction in the number of EIS points that are averaged into the resultant TIS can have an impact on the resulting TIS value. The current uncertainty budget does not independently isolate the random error of a single EIS measurement, so for the purpose of this discussion we will assume that the average of that random error is encapsulated in the Sensitivity Search Step Size uncertainty term defined in [Appendix G.11](#).

In general, the average of N repeat measurements containing a random uncertainty term, u_c , will reduce the corresponding random uncertainty by a factor of $1/\sqrt{N}$. Thus, reducing the number of data points for a given cut from N to M will increase the random uncertainty of that cut by the factor of $\sqrt{N/M}$. However, since each cut is weighted by the $\sin(\theta)$ term, the corresponding error contribution from that cut in the resulting TIS is also reduced by the same amount in linear units.

Rather than attempting to account for the $\sin(\theta)$ weighting of each curve, the assumption here will be that the total step size uncertainty increases by a factor of where $N=62$ for an evenly spaced 30 degree step TIS test, and $M=46$ for the theta dependent phi optimized pattern. In this case, $\sqrt{N/M}=1.16$, so that for a 0.5 dB step size, the fixed uncertainty contribution of ± 0.25 dB for the step size uncertainty becomes ± 0.29 dB with a rectangular distribution. Therefore, a standard uncertainty contribution of 0.167 dB shall be reported for the step size uncertainty instead of 0.144 dB when the theta dependent phi optimization is used.

G.24 Uncertainties of Forearm and Positioning of EUT on Forearm Phantom

G.24.1 Forearm Phantom Uncertainty

This uncertainty shall be determined using the method described in [Appendix G.10.3](#) except that the method is applied to the forearm phantom instead of a hand phantom.

When measuring the relative permittivity and conductivity, refer to [Table G-7](#) for the coordinates of twelve test locations defined for forearm phantoms, positioned relative to the coordinate system specified in [Figure G-7](#). [Figure G-8](#) highlights the test points on each face of the phantom.

For the forearm phantoms meeting the minimal requirements defined in [Appendix G.10.3](#), the approximations given in [Equation G.29](#) through [Equation G.31](#) shall be used to determine the forearm uncertainty where a rectangular distribution is assumed. The constants, c_1 , c_2 and a_1 , as used in [Equation G.29](#) and [Equation G.30](#), were determined for forearm phantoms according to the methodology of [Appendix I](#) to be $c_1 = 0.71$, $c_2 = 0.42$ and $a_1 = 0.50$.

As used in [Equation G.31](#), Δ_{shape} is the uncertainty on TRP, resulting from the tolerance of the forearm phantom Δ_{shape} . Since the forearms are usually manufactured with molds, the tolerance is 2% and therefore the effect is negligible, i.e., $c_3 = 0$. If the tolerance is larger, a numerical study as outlined in [Appendix I](#) must be conducted to determine Δ_{shape} .

The total standard uncertainty (root-sum-squares of $u_{\text{forearm_phantom_permittivity}}$, $u_{\text{forearm_phantom_conductivity}}$, $u_{\text{forearm_phantom_shape}}$) shall not exceed 0.5 dB.

TABLE G-7 COORDINATES OF TEN LOCATIONS FOR DIELECTRIC MEASUREMENTS ON THE FOREARM PHANTOM

Point	X (mm)	Y (mm)	Z (mm)
P1	Front Face	0	70
P2	Front Face	-15	35
P3	Front Face	15	15
P4	Front Face	-15	-15
P5	Front Face	15	-65
P6	Back Face	0	70
P7	Back Face	15	35
P8	Back Face	-15	15
P9	Back Face	15	-15
P10	Back Face	-15	-65
P11	0	Right Face	-15
P12	0	Left Face	15

FIGURE G-7 COORDINATE SYSTEM FOR DIELECTRIC TEST LOCATIONS

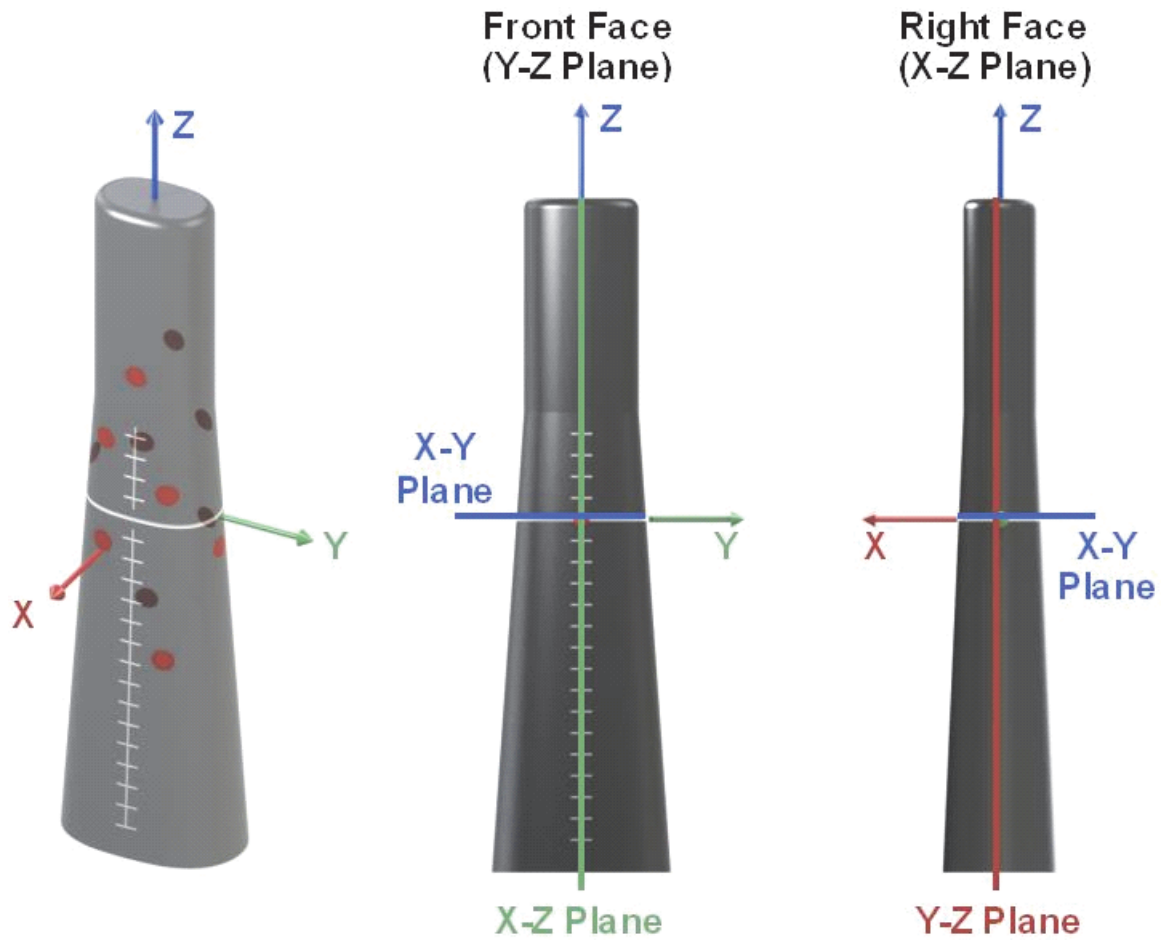
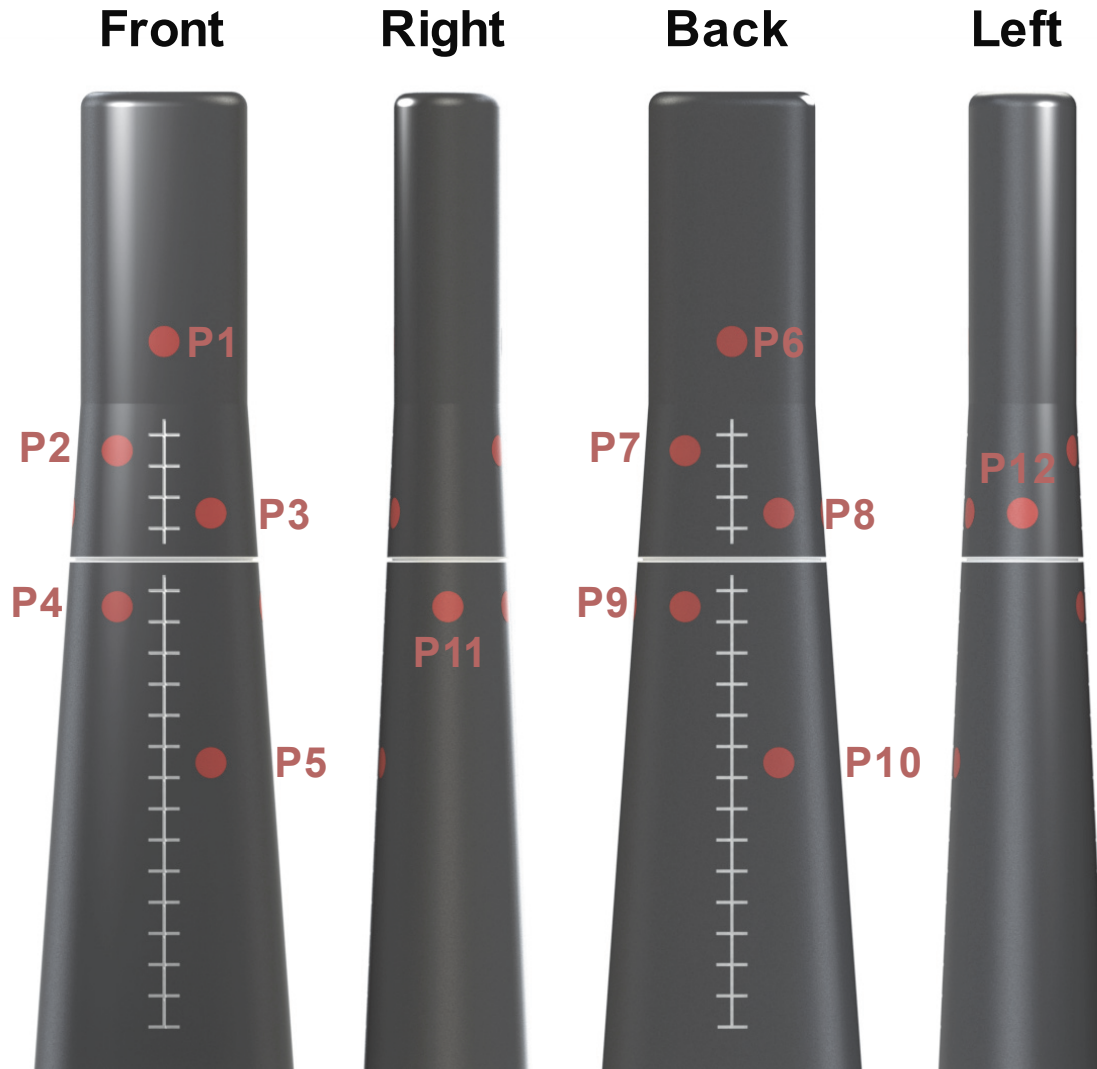

FIGURE G-8 TWELVE LOCATIONS FOR DIELECTRIC MEASUREMENTS ON THE FOREARM PHANTOM



G.24.2 Wrist-worn Device Positioning Uncertainty

This uncertainty shall be determined using the method described in Appendix G.10.5 except that the method is applied to the forearm phantom instead of a hand phantom.

When recording the position of the DUT relative to the available reference marks on the forearm phantom (Appendix G.10.5 step 2), include position offsets in directions h and v and angular rotations r_1 , r_2 and r_3 shown in Figure G-9. A numerical evaluation of the wrist-worn device positioning uncertainty was performed.

Based on the numerical evaluation, a similar approximation (Equation G.36) to that given for hands phantoms (Equation G.32) shall be used to determine the forearm phantom positioning uncertainty:

EQUATION G.36

$$U_{\text{positioning}} [dB] = \sqrt{(k_1 \cdot |h|)^2 + (k_2 \cdot |v|)^2 + (k_3 \cdot |r_1|)^2 + (k_4 \cdot |r_2|)^2 + (k_5 \cdot |r_3|)^2}$$

where: f is the deviation (see Figure G-9) in mm along the f -axis from the exact position described in Appendix Q.6 and must be determined according to the procedure defined below. The f -axis is in the X-Y plane, passes through the target test position and is parallel to the Y-axis.

g is the deviation (see Figure G-9) in mm along the g -axis from the exact position described in Appendix Q.6 and must be determined according to the procedure defined below. The g -axis is in the X-Z plane, passes through the target test position and is tangent to the conical section of the forearm phantom.

The e -axis is in the X-Z plane and is perpendicular to the f -axis and g -axis and is normal to the surface of the forearm phantom at the target test position.

r_1 , r_2 and r_3 are angular deviations (see Figure G-9) in degrees around the e -axis, f -axis and g -axis respectively from the exact position described in Appendix Q.6 and must be determined according to the procedure defined below.

$k_1 = 0.04$, $k_2 = 0.16$, $k_3 = 0.04$, $k_4 = 0.64$ and $k_5 = 0.10$ are the sensitivity factors which were determined according to the methodology of Appendix I. The maximum sensitivity has been expanded by the number of degrees of freedom. If the maximum deviations for f , g , r_1 , r_2 and r_3 are determined according to Appendix G.10.5, Step 6, then a rectangular distribution (divisor = 1.73) shall be used. If f , g , r_1 , r_2 and r_3 are determined as standard deviations assuming a normal distribution. In this case, the standard deviation shall be treated as a standard uncertainty (divisor = 1) shall be used in Table G-8. These equations are only valid for f and $g \leq 2$ mm, $r_1 \leq 5$ degrees, $r_2 \leq 2$ degrees and $r_3 \leq 0.5$ degrees.

FIGURE G-9 FOREARM POSITIONING UNCERTAINTY COMPONENTS

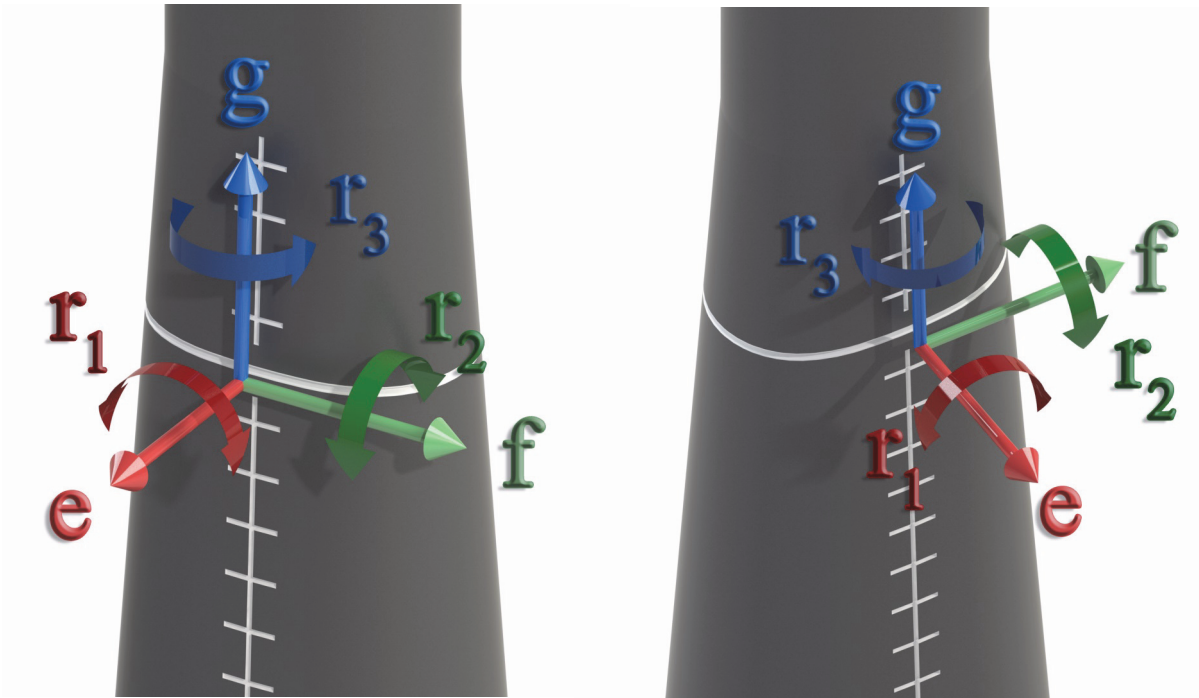

G.24.3 Uncertainty for Reasonably Worst-case Forearm and EUT Positioning on Forearm

The uncertainty for reasonably worst-case forearm and EUT positioning on forearm is provided in [Table G-8](#).

TABLE G-8 EXAMPLE OF UNCERTAINTY ASSESSMENT FOR REASONABLY WORST-CASE FOREARM AND EUT POSITIONING ON FOREARM

Uncertainty Component	Tolerance/ Uncertainty Value (± dB)	Probability Distribution	Divisor	c _i	Standard Uncertainty (± dB)	v _i or v _{eff}
	a		b	c	u _i = (a/b) × (c)	
Forearm Phantom						
Material Dielectric Constant	0.59	Rectangular	1.73	0.71	0.24	
Material Conductivity	1.10	Rectangular	1.73	0.42	0.29	
Geometry/Shape (incl. spacer)	<0.1	Rectangular	1.73	0.00	0.00	

TABLE G-8 EXAMPLE OF UNCERTAINTY ASSESSMENT FOR REASONABLY WORST-CASE FOREARM AND EUT POSITIONING ON FOREARM

Uncertainty Component	Tolerance/ Uncertainty Value (± dB)	Probability Distribution	Divisor	c _i	Standard Uncertainty (± dB)	v _i or v _{eff}
	a		b	c	u _i = (a/b) × (c)	
Combined Forearm Phantom Uncertainty					0.38	
Fixtures						
Forearm Phantom Fixture		Rectangular	1.73	0.00	0.00	
EUT Related						
EUT Positioning	0.37	Rectangular	1.73	1.00	0.21	
Combined Standard Uncertainty (Forearm)					0.43	

Forearm Phantom						
	$\Delta\epsilon_{avg}/\epsilon$	ϵ_{unc}/ϵ	ϵ_{std}/ϵ	a ₁	a	
Material Dielectric Constant	0.1	0.03	0.2	0.5	0.59	Reference Equation G.29
	$\Delta\sigma_{avg}/\sigma$	σ_{unc}/σ	σ_{std}/σ	a ₁	a	
Material Conductivity	0.2	0.05	0.4	0.5	1.10	Reference Equation G.30

EUT Related							
	g (mm)	f (mm)	r ₁ (deg)	r ₂ (deg)	r ₃ (deg)	a	
EUT Positioning	1	1	2	0.5	0.5	0.37	Reference Equation G.36

Appendix H Tissue Equivalent Dielectric Property Measurements (Normative)

This appendix describes the measurement of the dielectric properties of tissue-equivalent material. The head phantom is either filled with tissue simulating liquid or a solid or gel-like material. The hand is usually based on a carbon-filled silicone rubber material. This appendix intends to provide sufficient details to enable users to perform accurate measurement of the dielectric properties of liquid or solid materials including the corresponding uncertainties.

Besides relative permittivity and conductivity, the carbon-loaded polymer matrix materials used for making hand phantoms have other properties which must be carefully controlled, most notably DC resistance and stiffness. In carbon-loaded materials with increasing carbon concentrations, a point is reached, the percolation point, at which the particles are no longer completely isolated and the DC resistance of the entire macroscopic sample drops suddenly. Measurements of permittivity and conductivity on materials around this carbon concentration are believed to be subject to systematic instabilities, and need careful procedures.

An additional issue is that in solids with suspended particles, natural surfaces represent a unique plane, and may contain a much-reduced particle loading compared to any other sectional plane through the solid, where particles will intersect the plane. Cutting such material may result in release of a carbon film that may also strongly affect the measurements.

The open-ended coaxial probe (OCP) technique has demonstrated an acceptable degree of consistency between labs, even around the percolation point. Moreover, the published target dielectric properties for hand materials were derived from open-ended probe measurements on a sample of human hands. The OCP method shall be used for all surface dielectric property measurements. If the TEM transmission line technique is used for bulk property measurements, users shall show that their technique agrees with results obtained using the open-ended coaxial probe technique.

General procedures to evaluate dielectric parameter measurement uncertainties are provided in [Appendix G.16](#).

Note: *Due to the inability to assess the measurement uncertainty of the solid tissue equivalent material for the head phantom, the use of solid head phantoms is not allowed in the test plan at this time.*

H.1 Measurement Techniques

This section intends to provide sufficient detail and a test methodology based on the OCP method to enable users to perform dielectric property measurements of hand and head phantom materials. The dielectric parameters to be determined are the complex relative permittivity $\epsilon_r = \epsilon_r' - j\sigma/\omega\epsilon_0$ of the material.

It is recommended that with each delivered hand, manufacturers will provide two test samples of the material made from the same mix as the hand, one to be kept by the user, and the other by the manufacturer. The test samples shall be of the correct dimensions, or cast in a TEM line, to lend themselves to a quick check using one of the methods below.

H.2 Open-ended Coaxial Probe (OCP) Method

Gabriel has shown that data obtained on various carbon loaded materials using the open-ended coaxial measurement method encompass the required property range of proposed dielectric target values [4] [14].

One additional property of the hand materials that must be considered is their rubbery nature, which makes the surfaces readily compressible. The degree to which the coaxial sensor is pressed into the surface of the test sample has a significant effect on the results obtained. Sensors with a nominal diameter of at least 7 mm are to be preferred over smaller ones in this respect.

A cylindrical sample-under-test, such as can be provided by molding inside a 20 ml plastic syringe, alleviates the concern that might exist with a flat block that probe pressure causes the material directly under the probe tip to bow away from contact.

To obtain measurement consistency, the sensor can be supported on a framework that allows measurement at either a fixed contact pressure or at a fixed sensor displacement. In both cases, as contact is increased from a light touch, the dielectric results change, but above a certain critical pressure/penetration, stable results are obtained. Measurements shall be made in this condition. Investigations indicate that a pressure of around 500 kPa is necessary for this condition to be met, or a displacement of 3 mm. 500 kPa is equivalent to a load of 2 kg on a nominal 7 mm diameter probe.

Measurement at a fixed sensor displacement offers a considerable advantage over the fixed pressure technique by providing, at the same time, a simple measurement of the elastic modulus of the material-under-test. It is the elastic modulus which determines the ultimate stiffness of the molded hand. The NIST website at the link below shows how the deformation of a cylinder of material compressed between two plane surfaces relates to its elastic modulus.

<http://emtoolbox.nist.gov/elastic/case10.asp>

If, in this setup, the top plane surface is taken as the flat tip of the open-ended probe, and the lower plane is a load cell, the applied load read from the load cell for a fixed deformation relates directly to the material's elastic modulus.

Figure H-1 shows the physical set-up in the case of fixed displacement, and Figure H-2 the equivalent set up for fixed pressure.

FIGURE H-1 SETUP FOR FIXED DISPLACEMENT MEASUREMENT

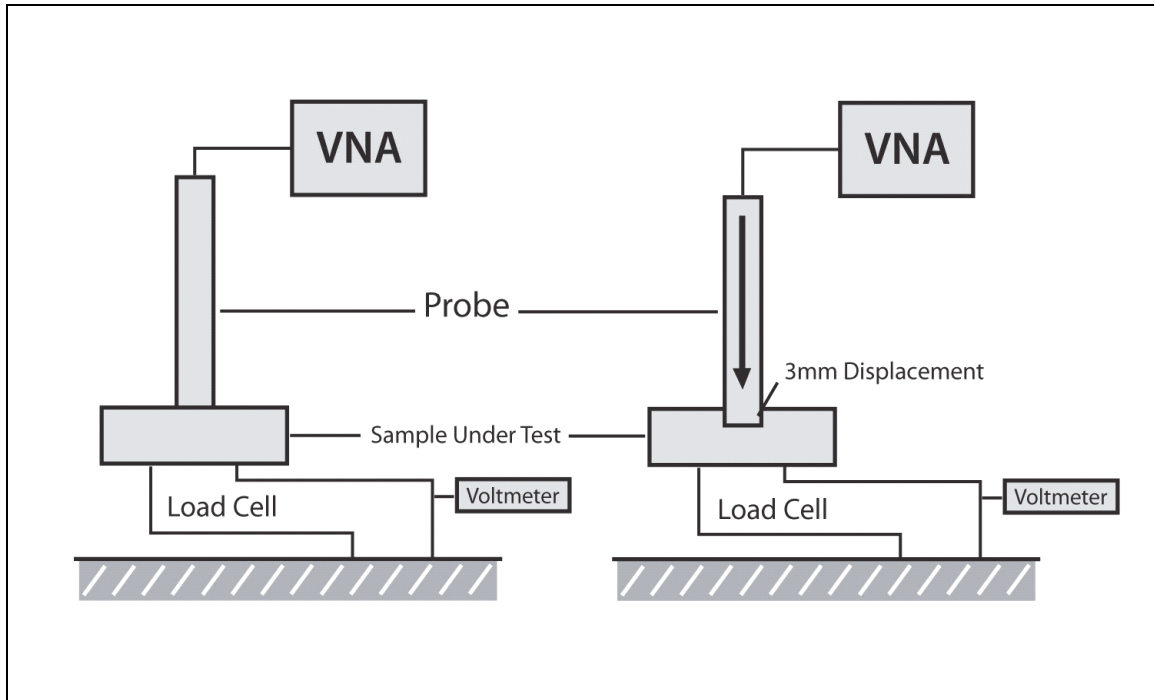
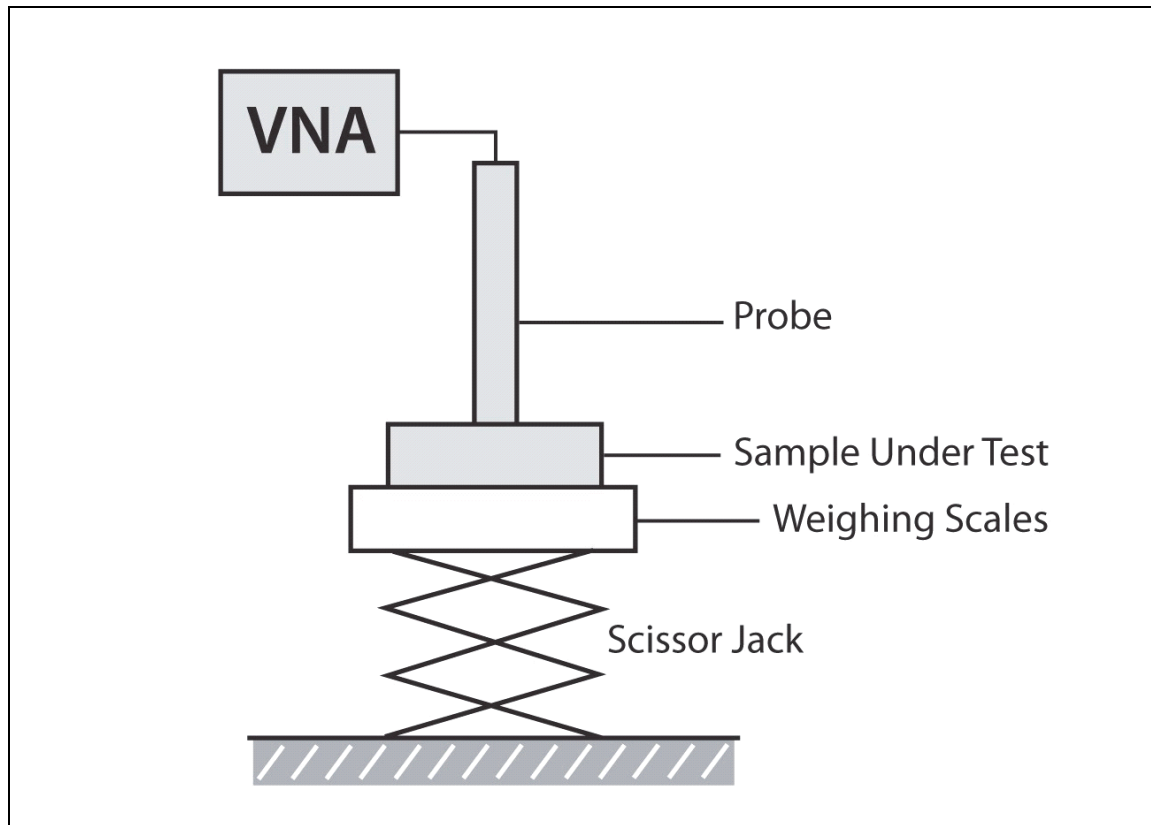

FIGURE H-2 SETUP FOR FIXED PRESSURE MEASUREMENT



Measurements are made by placing the probe in contact with the sample and measuring the admittance or reflection coefficient with respect to the open-circuit end, using a network analyzer or equivalent instrumentation [13]. To reduce measurement uncertainty, it is recommended that the measurement be repeated at least 10 times at different positions on the test sample, to minimize bias from abnormal readings caused by particulates of the same scale size as the probe dimension.

Test procedures should specify the network analyzer calibration and settings for the required frequency range. The application software should interpret the measured data to yield the dielectric properties of the sample as a function of frequency, together with an estimate of the standard deviation. To use this technique, a probe and a software package for the network analyzer has to be developed or obtained from a commercial source. The methodology should specify the probe size and applicable frequency range. [15] [16].

H.2.1 OCP Equipment Set-up

The equipment consists of a probe connected to one port of a vector network analyzer. The probe is an open-ended coaxial line, as shown in Figure H-3. Cylindrical coordinates (ρ, ϕ, z) are used where ρ is the radial distance from the axis, ϕ is the angular displacement around the axis, z is the displacement along the axis, a is the inner conductor radius, and b is the outer conductor inner radius.

Probes having the internal diameter of the outer conductor, $2b$, at least 5.5 mm are to be preferred to smaller ones since preliminary findings suggest that a degree of volume averaging occurs in the material under the probe tip. A flange may be included to better represent the infinite ground-plane assumption used in admittance calculations.

The network analyzer is configured to measure the magnitude and phase of the admittance. A one-port reflection calibration is performed at the plane of the probe by placing liquids for which the reflection coefficient can be calculated in contact with the probe. Three standards are needed for the calibration, typically a short circuit, air, and de-ionized water at a well-defined temperature (other reference liquids such as methanol or ethanol may be used for calibration).

Probes with or without flanges may be used. However, care should be taken if using flanged OCPs since “flange resonances” can cause large measurement errors when the diameter of the flange is approximately equal to half a wavelength in the dielectric medium. Such effects are most pronounced for high-permittivity liquids that have a loss tangent less than approximately 0.25 (at mobile phone frequencies these include water, methanol, and dimethyl sulphoxide). Therefore, it is strongly recommended that calibration is performed in a liquid having a high loss tangent, (e.g., ethanol) unless the sensor is immersed in a suitably large volume (e.g. 10 liters) of low loss tangent fluid.

FIGURE H-3 OPEN-ENDED COAXIAL PROBE WITH INNER AND OUTER RADII A AND B, RESPECTIVELY

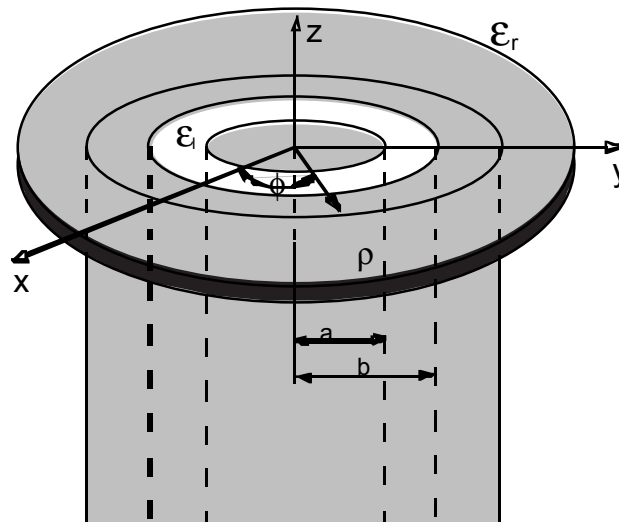

a is the inner conductor radius

b is the outer conductor inner radius

ϵ_r is the absolute permittivity of the medium outside the coaxial line

ϵ_i is the absolute permittivity of the medium inside the coaxial line

z is the displacement along the axis

ρ is the radial distance from the axis

ϕ is the angular displacement around the z-axis

(x, y, z) are the Cartesian coordinates

The calibration is a key part of the measurement procedure, and it is therefore important to ensure that it has been performed correctly. It can be checked by re-measuring the short circuit to ensure that a reflection coefficient of $\Gamma = -1.0$ (linear units) is obtained consistently or by a reference liquid with well known properties. The accuracy of the short-circuit measurement should be verified for each calibration at a number of frequencies. A short circuit can be achieved by gently pressing a piece of aluminum foil against the open end. For best electrical contact, the probe end should be flat and free of oxidation. Larger sensors without flanges generally have better foil short-circuit repeatability.

Measurement devices are commercially available.

H.2.2 Measurement Procedure

1. Configure and calibrate the network analyzer. Measurement uncertainty in the phase of the admittance measured by the OCP can be reduced by ensuring the calibration reference plane is located at the probe tip. This can be done by performing a full 12-term calibration with the probe replaced by an equivalent length of identical transmission line terminated at both ends (see Figure H-4).

FIGURE H-4 CALIBRATION OF VNA USING A DUMMY PROBE WHOSE ELECTRICAL LENGTH IS THE SAME AS THE ACTUAL OCP

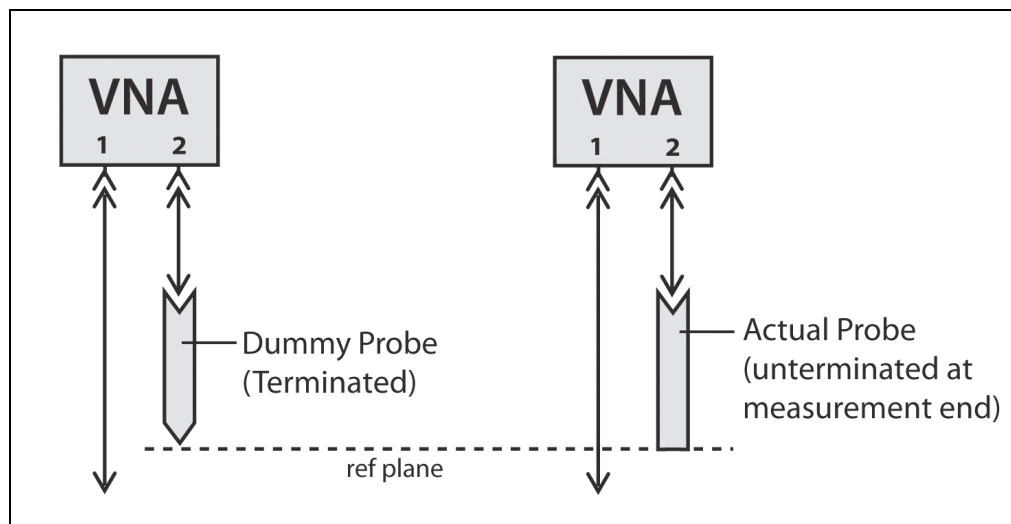

2. Replace the OCP and calibrate against an open circuit, a short circuit, and a fluid whose electrical properties are known at a reference temperature.
3. Place the sample in the measurement fixture, and bring the probe squarely into contact with the surface.
4. Depending on the measurement technique chosen, either depress the probe by a fixed distance, say 3 mm, and measure the change in reading on the load cell, or place the sample on weighing scales and offer the sample up to the probe using a scissor jack until a set change in reading is obtained on the scales.

5. Measure the complex admittance with respect to the probe aperture.
6. Compute the complex relative permittivity $\epsilon_r = \epsilon'_r - j\sigma/\omega\epsilon_0$, for example from the equation [14].

$$Y = \frac{j2\omega\epsilon_r\epsilon_0}{[\ln(b/a)]^2} \int_a^b \int_a^b \int_0^\pi \cos\phi' \frac{\exp[-j\omega(\mu_0\epsilon_r\epsilon_0)^{1/2}r]}{r} d\phi' d\rho' d\rho$$

This expression can be computed numerically, or expanded into a series and simplified. The equation is first solved for the sample wave number k then the sample complex permittivity, using Newton-Raphson or other iterative approximations. Other numerical approaches may be used provided the application software has been thoroughly tested and checked via measurements of reference liquids. Commercially available open-ended coaxial probe kits typically use versions of this theory and method.

H.3 TEM Transmission Line Method

As outlined in the introduction, the TEM transmission line method shall only be applied if it has been shown to be equivalent to the open coaxial probe method for the carbon loaded dielectric materials. This documentation shall be made available. The TEM transmission line method shall not be used for dielectric measurements of the surface of the hand phantoms.

TEM transmission line method is based on the measurement of the complex transmission coefficient of a TEM-mode coaxial transmission line filled with the test sample. The measurement of transmission coefficient is performed using a vector network analyzer to determine magnitude and phase of the scattering coefficient S_{21} . The measured data is then used to calculate the complex permittivity as a function of frequency.

H.3.1 TEM Equipment Set-up

The measuring set-up is shown in [Figure H-5](#). It consists of a vector network analyzer, a temperature sensor and a sample holder. The sample holder is a coaxial transmission line using the TEM dominant mode.

FIGURE H-5 TEM TRANSMISSION LINE DIELECTRIC MEASUREMENT METHOD SETUP

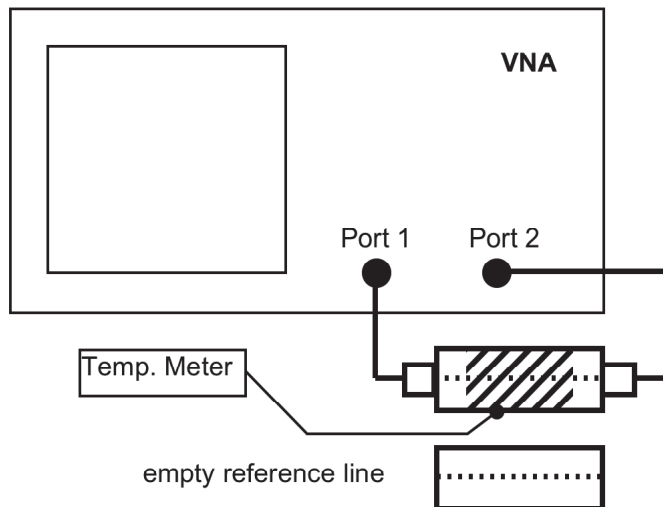

As shown in [Figure H-6](#) and [Figure H-7](#), the set-up can be implemented using either a cylindrical (coaxial) or a planar (strip-line) geometry, as long as the empty cell is of 50 ohm impedance. The same equations apply for both. The strip-line implementation described by Toropainen has been widely used for liquids measurements [17]. Different lengths of the sensor can be selected for optimum measurements depending upon the lossiness of the materials. A line of between 80-160 mm is suitable for measurement of hand materials.

FIGURE H-6 GEOMETRY OF THE SAMPLE HOLDER (DIELECTRIC TEST CELL, DIMENSIONS IN MM)

INJECTED SAMPLE MATERIAL (2), (B) OUTER CONDUCTOR (1) AND (C) INNER CONDUCTOR (3) OF THE COAXIAL LINE.

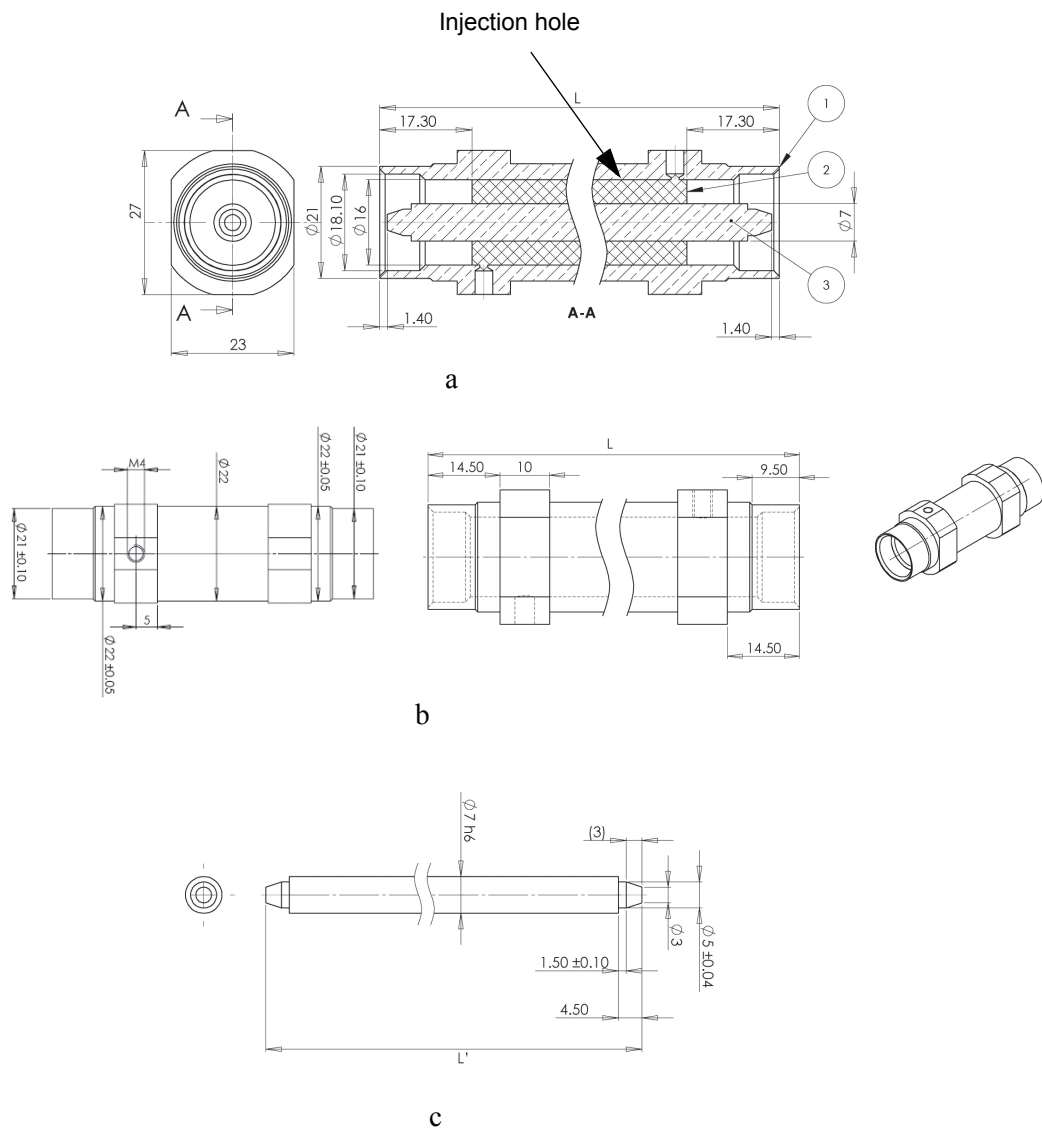
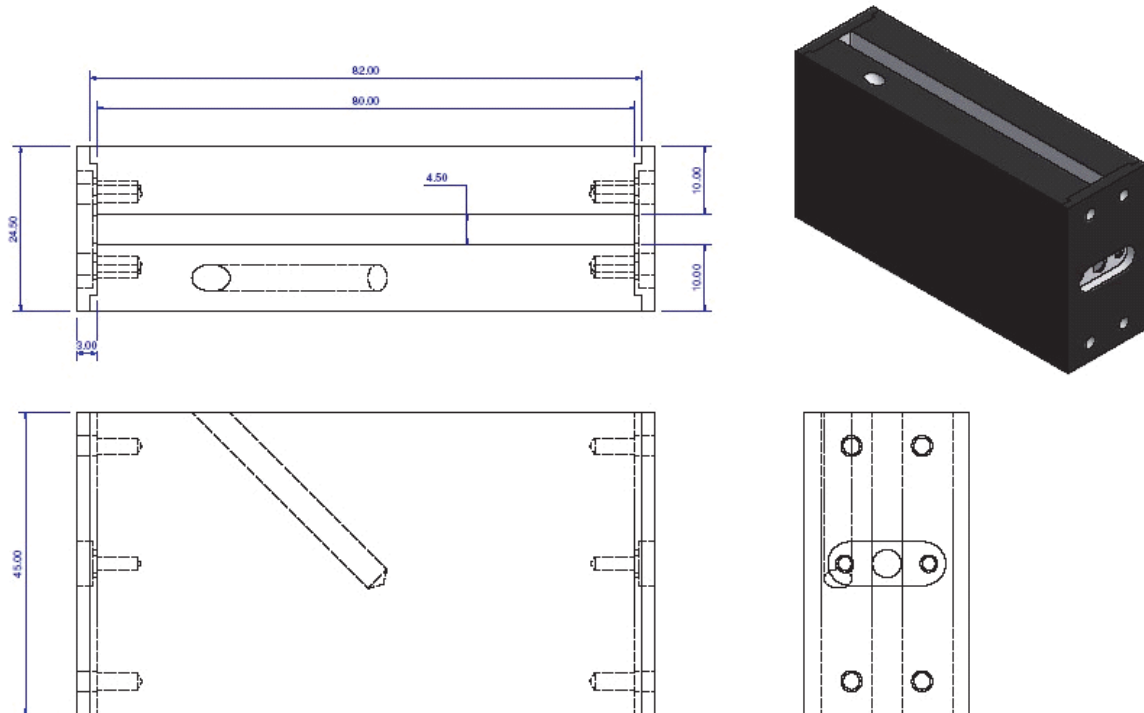

FIGURE H-7 CONSTRUCTION DIAGRAM OF STRIP-LINE TEM SENSOR (ALL DIMENSIONS IN MM)



The solution to the equations in [Appendix H.3.2](#) is not unique and it is possible to obtain the wrong solution if a narrow measurement frequency range is used with materials of unknown composition. Use of a wide frequency range for measurement ensures selection of the appropriate solution.

Neither the strip-line sensor, nor the coaxial implementation proposed in [Figure H-6](#) and [Figure H-7](#) are particularly convenient for solids material measurements if the cell has to be dismantled to remove the solid sample after use.

The cross section of the sample and the holder is constant. The dimensions are optimized for required frequency range to minimize the effects of higher order modes, have a sufficiently large sample and allow usage of industrially available connectors. The sample length is selected for not exceeding the dynamic range of the analyzer at the highest frequency (100 mm are equivalent to 60 dB attenuation at 3 GHz). The sample to be measured is injected into the cell in vacuum condition to avoid air bubbles and air gaps. The process of filling and consecutive hardening is equivalent to the production process of the hand phantom. In case of shrinking of the material during the hardening process, the length difference has to be considered in the evaluation. Gaps in the radial direction must be avoided.

H.3.2 Measurement Procedure

1. Configure and calibrate the network analyzer such that the reference planes coincide with the sample holder ports.

2. Record the magnitude and phase of S_{21}^0 of the empty reference sample holder at the desired frequencies.
3. Connect the holder with the sample material mounted and repeat the measurement to obtain the transmission coefficient with the sample S_{21}^S .
4. Calculate the complex permittivity of the sample from the magnitude and phase of S_{21}^S / S_{21}^0 by a solution of the equations.

$$\frac{S_{21}^S}{S_{21}^0} = \frac{(1 - \Gamma^2) \exp[-j(k - k_0)d]}{1 - \Gamma^2 \exp(-j2kd)},$$

$$\Gamma = \frac{1 - \sqrt{\epsilon_r}}{1 + \sqrt{\epsilon_r}},$$

$$k = \frac{2\pi f}{c_0} \sqrt{\epsilon_r}, k_0 = \frac{2\pi f}{c_0}$$

where:

Γ is the reflection coefficient at either end of the TEM line (air/material interface);

k is the wave number in the sample;

k_0 is the free-space wave number;

d is the length of the sample in the TEM line;

f is the frequency;

c_0 is the free-space speed of light;

$\epsilon_r = \epsilon_r' - j\sigma/\omega\epsilon_0$ is the complex relative permittivity of the sample.

The measurement accuracy can be increased by considering the influence of the triple pass wave in the well-known length of the sample. Considerations regarding this method and related restrictions are discussed in the following reference [18].

Appendix I Assessment of Uncertainty Values using Simulation Tools (Normative)

I.1 Introduction

Uncertainty assessments are always relative evaluations and therefore well suited for numerical simulation tools which provide the most appropriate technique to compare different configurations. It can be guaranteed that the relative accuracy is significantly better than 0.1 dB. The simulation tools can be used for Type B and Type A evaluations. Type A evaluations require sufficient computational resources and scripting of the input file to satisfy the required random modifications. Type B evaluations are straightforward and consider only the average and both maximum bounds of the tolerance.

The purpose of this appendix is to describe the concept of uncertainty assessment using simulation tools including the validation of the tool and numerical evaluation procedure.

I.2 Requirements for the Simulation Software

The basic requirements of the simulation software must be the following:

- Import of mobile phone CAD data (typically, >500 parts) as well as head/hand/forearm phantoms and fixture data
- Accurate simulation of mobile phones with homogenous head, hand and forearm phantoms including effect on impedance, efficiency, and performance
- Position of mobile phone and phantoms with high precision
- Evaluation of end points specified in [Appendix G](#)
- Scripting abilities

I.3 Simulation Software Validation

The simulation software should be validated by the manufacturers according to the following:

- Checking the correct evaluation of the end points specified in [Appendix G](#) of dipoles
- Checking the correct evaluation of the end points specified in [Appendix G](#) of dipoles with different locations of the absorbing boundary conditions (ABC) if applicable
- Computation of the benchmark examples listed in IEEE P1528.1™/D1.0 [19] and IEEE P1528.4™/D1.0 [20] following the procedure defined in the same documents
- Computation of the benchmark examples of SAM phantom, as defined by Beard et. al [21], using different meshing densities

I.4 Phone Validation

The uncertainty evaluation requires different mobile phone models (see [Appendix G](#)).

- The phone models including effects of back scattering on the impedance shall be validated by SAR distribution or near-field free space comparison (distance to the surface of the phone less than 20 mm) for different distances from the phone, e.g., 5 mm, and 10 mm. If the deviation of all distances with respect to the peak and pattern (gamma method comparison) is less than 15%, the phone can be considered validated.
- The phone models shall be validated by TRP and efficiency comparisons.

I.5 Computation of the Uncertainty for Type B Evaluation

Type B evaluations are straightforward. Only the average and both maximum bounds of the tolerance will be considered, whereas, the rectangular distribution is assumed. These cases are computed with the previously validated code and for different phone models if required. The difference in the end points specified in [Appendix G](#) compared to the standard case will be compared and the maximum will be used for the uncertainty budget.

I.6 Computation of the Uncertainty for Type A Evaluation

Although Type A evaluations require more powerful tools than Type B evaluations, they are more reliable. A parameter distribution is experimentally determined or predicted. These parameters are then scripted in the software tool and the magnitude of the parameters is randomly assigned and compliant with the determined distribution. The difference in the end points specified in [Appendix G](#) is evaluated for each simulation case in which an appropriate statistical analysis shall be performed.

I.7 Numerical Evaluation of Head and Hand Phantom Fixtures Uncertainty

The numerical evaluation compares the differences between the end points specified in [Appendix G](#) with and without fixtures and mounting structures. Type A and B evaluations shall be applied, the highest of which shall be used.

The evaluation procedure requires the existence of CAD model files of the different phone models, head and hand phantoms, and their fixtures. A proposed and recommended procedure for importing and preprocessing the phone model can be found in IEEE P1528.3™/D2.0 [22].

1. Import antenna and PCB of the handset model into simulation software.
2. Model source by implementing a feed gap or other source model.
3. Import the remaining parts in order of importance and set material parameters.
4. Validate the phone in free-space by comparing near-field according to [Appendix I.5](#).
5. Import models of the head and hand phantoms into the same model space and set material parameters according to [Appendix C](#).
6. Position the phone with respect to the head and hand phantoms according to the procedure defined in [Appendix A](#).
7. Import models of head and hand phantom fixtures and mounting structures into the same model space.
8. Position them to operate as fixture and/or mounting structures and set material parameters.

9. Perform the initial simulation for each frequency band and evaluate the end points specified in [Appendix G](#).
10. Without changing any simulation settings and discretizations, repeat step 9 without fixtures and mounting structures.

I.8 Numerical Evaluation of Device Positioning Uncertainty

Numerical evaluation of device positioning uncertainty is a Type A uncertainty analysis which is conducted using high-end simulation tools supporting scripting of mechanical positioning.

The first step of the procedure, as described in [Appendix G.10.5.1](#), is conducted without measurement. A mechanical position matrix is derived for which the analysis is conducted following the procedures described in [Appendix I](#).

1. Import antenna and PCB of the device model into simulation software.
2. Model source by implementing a feed gap or other source model.
3. Import the remaining parts in order of importance and set material parameters.
4. Validate the device in free-space by comparing near-field according to [Appendix I.5](#).
5. Import models of the head, hand or forearm phantoms into the same model space and set material parameters according to [Appendix C](#).
6. Position the device with respect to the phantoms according to the procedure defined in [Appendix A](#).
7. Import models of phantom fixtures and mounting structures into the same model space.
8. Position them to operate as fixture and/or mounting structures and set material parameters.
9. Perform the initial simulation for each frequency band and evaluate the end points specified in [Appendix G](#).
10. Using scripting features of simulation software, generate different simulation projects according to the mechanical position matrix. Each project has to use the same simulation settings and discretization of the device as in the initial simulation.
11. Repeat step 1 to step 10 for each phone model.
12. Performance of the statistical evaluation of the simulated data per device for the end points specified in [Appendix G](#). The largest standard deviation shall be used for the uncertainty budget with a degree of freedom equal to $M/n-1$, where M is the total number of simulations, and n is the number of EUTs used in the simulations. If there are a sufficient number of simulations, then a more sophisticated ANOVA analysis can be performed.

I.9 Numerical Evaluation of Head, Hand and Forearm Phantom Shape Uncertainty

The head phantom shape uncertainty is the effect of the production tolerances of the inner and outer surfaces of the shell. The hand and forearm phantom shape uncertainty results from the production tolerance of the outer surface of the phantom. If the tolerance in both case is not within 2% from the specified dimensions in the CAD files, then a numerical evaluation must be conducted to determine the uncertainty.

The numerical evaluation procedure requires the existence of CAD model files of the original of head/hand/forearm phantoms and the phantoms with shapes deviated from the original. Following the proposed and recommended procedure in IEEE P1528.1™/D1.0 [19], IEEE P1528.4™/D1.0 [20] and IEEE P1528.3™/D2.0 [22], the device models are initially simulated with the original head, hand and forearm phantoms and the end points specified in [Appendix G](#) are evaluated for each frequency band. The simulations are then repeated after the original models are replaced with the deviated models. The end points specified in [Appendix G](#) obtained in both cases are compared to determine the uncertainty value due to the tolerance of phantom shape.

I.10 Numerical Evaluation of Head Phantom Support Material Uncertainty

The head phantom support material uncertainty results from the supporting dielectric structures of the head phantom. If the effect of the supporting material on the end points specified in [Appendix G](#) cannot be neglected then a numerical evaluation must be conducted.

The numerical evaluation compares the differences between the end points specified in [Appendix G](#) with and without head phantom support/mounting structures. Following the proposed and recommended procedure in IEEE P1528.1™/D1.0 [19], IEEE P1528.4™/D1.0 [20] and IEEE P1528.3™/D2.0 [22], the phone models are initially simulated with the original head phantom without supporting material and the end points specified in [Appendix G](#) are evaluated for each frequency band. The simulations are then repeated after the supporting/mounting structure is added to the head phantom. The end points specified in [Appendix G](#) obtained in both cases are compared to determine the uncertainty value due to the head phantom supporting/mounting structure.

Appendix J Lab Repeatability Evaluation (Normative)

The laboratory repeatability evaluation is a check of the repeatability of the OTA evaluations; it is recommended that the evaluation be conducted once per year or more frequently, depending on any changes in the staff performing the OTA test.

The repeatability evaluation can be conducted within a short period or distributed over the year. It shall be conducted for the following endpoints:

- Total Radiated Power (TRP)
- Total Isotropic Sensitivity (TIS)
- Power radiated over ± 45 degrees near the Horizon (NHPRP ± 45)
- Power radiated over ± 30 degrees near the Horizon (NHPRP ± 30)

A Type A uncertainty analysis consists of the following steps and shall be repeated for each person who may perform tests (T_x) using at least two different EUTs (D_x). The EUTs can be reference phones which have been verified to be stable.





All the phones used in the study shall be characterized and documented.

1. Shut down all equipment and unmount head and phone.
2. Set up and verify the system is functioning properly as usually performed before a test
3. Select the measurement order of devices D_x ($D_1 \dots D_n$) operating at test frequencies f_x ($f_1 - f_l$) and measured by the technicians T_x ($T_1 \dots T_m$), where n shall be larger than 3 and equally divided between monoblock and fold phones with at least one antenna at the bottom of the device.
4. Test person T_x mount device D_x in the hand phantom and at the head phantom.
5. Determine TRP/NHPRP/UHRP/PGRP for the selected frequencies.
6. The same test person T_x mounts Device D_{x+1} in the hand and at the head and repeat steps 3 and 4.
7. Change technicians and repeat steps 1 and 5 until all technicians have positioned each phone at least once and at least 10 evaluations have been performed for each device, i.e., number of measurements M shall be equal to or larger than 40 times the number of test frequencies
8. Performance of the statistical evaluation of the measured data per device for TRP, NHPRP $\pm 30^\circ$, NHPRP $\pm 45^\circ$. The largest standard deviation shall be used for the uncertainty budget with a degree of freedom equal to $M/n-1$. If there are a sufficient number of measurements then a more sophisticated ANOVA analysis can be performed.

Determine the distribution of the results and the standard deviations for all assessments. The distribution should be close to Gaussian and none of standard deviation should exceed the uncertainty of the laboratory repeatability as determined according to [Section 7](#).

Appendix K Intermediate Channel Lists (Normative)

This appendix describes the exact intermediate channels that shall be tested for relative sensitivity for each air interface.

	The green cells represent the low, middle and high channels that are fully tested for TIS.
	The yellow cells represent the lower 25% of the intermediate channels.
	The white cells represent the middle 50% of the intermediate channels.
	The orange cells represent the upper 25% of the intermediate channels.

K.1 CDMA Intermediate Channel List

This intermediate channel list shall be used for CDMA, CDMA 1xEV-DO and CDMA 1xRTT.

TABLE K-1 CDMA 800 INTERMEDIATE CHANNEL LIST

CDMA 800	
Channel	Frequency (MHz)
1013	869.70
1023	870.00
16	870.48
32	870.96
48	871.44
64	871.92
80	872.40
96	872.88
112	873.36
128	873.84
144	874.32
160	874.80
176	875.28
192	875.76
208	876.24
224	876.72
240	877.20

TABLE K-1 CDMA 800 INTERMEDIATE CHANNEL LIST

CDMA 800	
Channel	Frequency (MHz)
256	877.68
272	878.16
288	878.64
304	879.12
311	879.33
356	880.68
368	881.04
384	881.52
400	882.00
416	882.48
432	882.96
448	883.44
464	883.92
480	884.40
496	884.88
512	885.36
528	885.84
544	886.32
560	886.80
576	887.28
592	887.76
608	888.24
624	888.72
640	889.20
644	889.32
689	890.67
694	890.82
739	892.17
752	892.56
768	893.04
777	893.31

TABLE K-2 CDMA 1900 INTERMEDIATE CHANNEL LIST

CDMA 1900	
Channel	Frequency (MHz)
25	1931.25
30	1931.50
40	1932.00
50	1932.50
60	1933.00
70	1933.50
80	1934.00
90	1934.50
100	1935.00
110	1935.50
120	1936.00
130	1936.50
140	1937.00
150	1937.50
160	1938.00
170	1938.50
180	1939.00
190	1939.50
200	1940.00
210	1940.50
220	1941.00
230	1941.50
240	1942.00
250	1942.50
260	1943.00
270	1943.50
280	1944.00
290	1944.50
300	1945.00
310	1945.50
320	1946.00
330	1946.50
340	1947.00
350	1947.50
360	1948.00
370	1948.50
380	1949.00

TABLE K-2 CDMA 1900 INTERMEDIATE CHANNEL LIST

CDMA 1900	
Channel	Frequency (MHz)
390	1949.50
400	1950.00
410	1950.50
420	1951.00
430	1951.50
440	1952.00
450	1952.50
460	1953.00
470	1953.50
480	1954.00
490	1954.50
500	1955.00
510	1955.50
520	1956.00
530	1956.50
540	1957.00
550	1957.50
560	1958.00
570	1958.50
580	1959.00
590	1959.50
600	1960.00
610	1960.50
620	1961.00
630	1961.50
640	1962.00
650	1962.50
660	1963.00
670	1963.50
680	1964.00
690	1964.50
700	1965.00
710	1965.50
720	1966.00
730	1966.50
740	1967.00
750	1967.50
760	1968.00

TABLE K-2 CDMA 1900 INTERMEDIATE CHANNEL LIST

CDMA 1900	
Channel	Frequency (MHz)
770	1968.50
780	1969.00
790	1969.50
800	1970.00
810	1970.50
820	1971.00
830	1971.50
840	1972.00
850	1972.50
860	1973.00
870	1973.50
880	1974.00
890	1974.50
900	1975.00
910	1975.50
920	1976.00
930	1976.50
940	1977.00
950	1977.50
960	1978.00
970	1978.50
980	1979.00
990	1979.50
1000	1980.00
1010	1980.50
1020	1981.00
1030	1981.50
1040	1982.00
1050	1982.50
1060	1983.00
1070	1983.50
1080	1984.00
1090	1984.50
1100	1985.00
1110	1985.50
1120	1986.00
1130	1986.50
1140	1987.00

TABLE K-2 CDMA 1900 INTERMEDIATE CHANNEL LIST

CDMA 1900	
Channel	Frequency (MHz)
1150	1987.50
1160	1988.00
1170	1988.50
1175	1988.75

TABLE K-3 CDMA 2100/1700 BAND (3GPP2 BAND CLASS 15) INTERMEDIATE CHANNEL LIST

CDMA 2100/1700	
Channel	Frequency (MHz)
25	2111.25
30	2111.50
40	2112.00
50	2112.50
60	2113.00
70	2113.50
80	2114.00
90	2114.50
100	2115.00
110	2115.50
120	2116.00
130	2116.50
140	2117.00
150	2117.50
160	2118.00
170	2118.50
180	2119.00
190	2119.50
200	2120.00
210	2120.50
220	2121.00
230	2121.50
240	2122.00
250	2122.50
260	2123.00
270	2123.50
280	2124.00

TABLE K-3 CDMA 2100/1700 BAND (3GPP2 BAND CLASS 15) INTERMEDIATE CHANNEL LIST

CDMA 2100/1700	
Channel	Frequency (MHz)
290	2124.50
300	2125.00
310	2125.50
320	2126.00
330	2126.50
340	2127.00
350	2127.50
360	2128.00
370	2128.50
380	2129.00
390	2129.50
400	2130.00
410	2130.50
420	2131.00
430	2131.50
440	2132.00
450	2132.50
460	2133.00
470	2133.50
480	2134.00
490	2134.50
500	2135.00
510	2135.50
520	2136.00
530	2136.50
540	2137.00
550	2137.50
560	2138.00
570	2138.50
580	2139.00
590	2139.50
600	2140.00
610	2140.50
620	2141.00
630	2141.50
640	2142.00
650	2142.50

TABLE K-3 CDMA 2100/1700 BAND (3GPP2 BAND CLASS 15) INTERMEDIATE CHANNEL LIST

CDMA 2100/1700	
Channel	Frequency (MHz)
660	2143.00
670	2143.50
680	2144.00
690	2144.50
700	2145.00
710	2145.50
720	2146.00
730	2146.50
740	2147.00
750	2147.50
760	2148.00
770	2148.50
780	2149.00
790	2149.50
800	2150.00
810	2150.50
820	2151.00
830	2151.50
840	2152.00
850	2152.50
860	2153.00
870	2153.50
875	2153.75

K.2 GSM Intermediate Channel List

All channels shall be tested for GSM, GPRS and EGPRS 850/1900 for the intermediate channel test.

K.3 UMTS (WCDMA) Intermediate Channel List

This intermediate channel list shall be used for UMTS.

TABLE K-4 UMTS 850 INTERMEDIATE CHANNEL LIST

UMTS 850	
Channel	Frequency (MHz)
4357	871.40
4360	872.00
4372	874.40
4384	876.80
4396	879.20
4408	881.60
4420	884.00
4432	886.40
4444	888.80
4456	891.20
4458	891.60

TABLE K-5 UMTS 1900 INTERMEDIATE CHANNEL LIST

UMTS 1900	
Channel	Frequency (MHz)
9662	1932.40
9668	1933.60
9680	1936.00
9692	1938.40
9704	1940.80
9716	1943.20
9728	1945.60
9740	1948.00
9752	1950.40
9764	1952.80
9776	1955.20
9788	1957.60
9800	1960.00
9812	1962.40
9824	1964.80
9836	1967.20

TABLE K-5 UMTS 1900 INTERMEDIATE CHANNEL LIST

UMTS 1900	
Channel	Frequency (MHz)
9848	1969.60
9860	1972.00
9872	1974.40
9884	1976.80
9896	1979.20
9908	1981.60
9920	1984.00
9932	1986.40
9938	1987.60

TABLE K-6 UMTS 2100/1700 INTERMEDIATE CHANNEL LIST

UMTS 2100/1700	
Channel	Frequency (MHz)
1537	2112.40
1542	2113.40
1554	2115.80
1566	2118.20
1578	2120.60
1590	2123.00
1602	2125.40
1614	2127.80
1626	2130.20
1638	2132.60
1650	2135.00
1662	2137.40
1674	2139.80
1686	2142.20
1698	2144.60
1710	2147.00
1722	2149.40
1734	2151.80
1738	2152.60

K.4 LTE Intermediate Channel List

TABLE K-7 LTE INTERMEDIATE CHANNEL MEASUREMENTS TABLE

Band	Channel Bandwidth (MHz)	Channel	Frequency (MHz)	UL RB Allocation	DL RB Allocation
2 ¹	10	650	1935	50 RB with RBstart=0	50 RB with RBstart=0
2	10	740	1944	50 RB with RBstart=0	50 RB with RBstart=0
2	10	820	1952	50 RB with RBstart=0	50 RB with RBstart=0
2	10	900	1960	50 RB with RBstart=0	50 RB with RBstart=0
2	10	980	1968	50 RB with RBstart=0	50 RB with RBstart=0
2	10	1060	1976	50 RB with RBstart=0	50 RB with RBstart=0
2	10	1150	1985	50 RB with RBstart=0	50 RB with RBstart=0
4 ²	10	2000	2115	50 RB with RBstart=0	50 RB with RBstart=0
4	10	2090	2124	50 RB with RBstart=0	50 RB with RBstart=0
4	10	2175	2132.5	50 RB with RBstart=0	50 RB with RBstart=0
4	10	2260	2141	50 RB with RBstart=0	50 RB with RBstart=0
4	10	2350	2150	50 RB with RBstart=0	50 RB with RBstart=0
5 ^{3, 4}	10	2450	874	25 RB with RBstart=25	50 RB with RBstart=0
5	10	2525	881.5	25 RB with RBstart=25	50 RB with RBstart=0
5	10	2600	889	25 RB with RBstart=25	50 RB with RBstart=0
12	5	5035	731.5	20 RB with RBstart=5	25 RB with RBstart=0
12	5	5065	734.5	20 RB with RBstart=5	25 RB with RBstart=0
12	5	5095	737.5	20 RB with RBstart=5	25 RB with RBstart=0
12	5	5125	740.5	20 RB with RBstart=5	25 RB with RBstart=0
12	5	5155	743.5	20 RB with RBstart=5	25 RB with RBstart=0
25 ¹	5	8065	1932.5	25 RB with RBstart=0	25 RB with RBstart=0
25	5	8105	1936.5	25 RB with RBstart=0	25 RB with RBstart=0
25	5	8145	1940.5	25 RB with RBstart=0	25 RB with RBstart=0
25	5	8185	1944.5	25 RB with RBstart=0	25 RB with RBstart=0
25	5	8225	1948.5	25 RB with RBstart=0	25 RB with RBstart=0
25	5	8265	1952.5	25 RB with RBstart=0	25 RB with RBstart=0
25	5	8305	1956.5	25 RB with RBstart=0	25 RB with RBstart=0
25	5	8345	1960.5	25 RB with RBstart=0	25 RB with RBstart=0
25	5	8365	1962.5	25 RB with RBstart=0	25 RB with RBstart=0

TABLE K-7 LTE INTERMEDIATE CHANNEL MEASUREMENTS TABLE

Band	Channel Bandwidth (MHz)	Channel	Frequency (MHz)	UL RB Allocation	DL RB Allocation
25	5	8385	1964.5	25 RB with RBstart=0	25 RB with RBstart=0
25	5	8425	1968.5	25 RB with RBstart=0	25 RB with RBstart=0
25	5	8465	1972.5	25 RB with RBstart=0	25 RB with RBstart=0
25	5	8505	1976.5	25 RB with RBstart=0	25 RB with RBstart=0
25	5	8545	1980.5	25 RB with RBstart=0	25 RB with RBstart=0
25	5	8585	1984.5	25 RB with RBstart=0	25 RB with RBstart=0
25	5	8625	1988.5	25 RB with RBstart=0	25 RB with RBstart=0
25	5	8665	1992.5	25 RB with RBstart=0	25 RB with RBstart=0
26 ³	5	8715	861.5	25 RB with RBstart=0	25 RB with RBstart=0
26	5	8755	865.5	25 RB with RBstart=0	25 RB with RBstart=0
26	5	8795	869.5	25 RB with RBstart=0	25 RB with RBstart=0
26	5	8835	873.5	25 RB with RBstart=0	25 RB with RBstart=0
26	5	8865	876.5	25 RB with RBstart=0	25 RB with RBstart=0
26	5	8895	879.5	25 RB with RBstart=0	25 RB with RBstart=0
26	5	8935	883.5	25 RB with RBstart=0	25 RB with RBstart=0
26	5	8975	887.5	25 RB with RBstart=0	25 RB with RBstart=0
26	5	9015	891.5	25 RB with RBstart=0	25 RB with RBstart=0
7	20	2850	2630	75 RB with RBstart=25	100 RB with RBstart=0
7	20	2975	2642.5	75 RB with RBstart=25	100 RB with RBstart=0
7	20	3100	2655	75 RB with RBstart=25	100 RB with RBstart=0
7	20	3225	2667.5	75 RB with RBstart=25	100 RB with RBstart=0
7	20	3350	2680	75 RB with RBstart=25	100 RB with RBstart=0
41	20	39750	2506	100 RB with RBstart=0	100 RB with RBstart=0
41	20	39930	2524	100 RB with RBstart=0	100 RB with RBstart=0
41	20	40110	2542	100 RB with RBstart=0	100 RB with RBstart=0
41	20	40280	2559	100 RB with RBstart=0	100 RB with RBstart=0
41	20	40450	2576	100 RB with RBstart=0	100 RB with RBstart=0
41	20	40620	2593	100 RB with RBstart=0	100 RB with RBstart=0
41	20	40790	2610	100 RB with RBstart=0	100 RB with RBstart=0
41	20	40960	2627	100 RB with RBstart=0	100 RB with RBstart=0
41	20	41130	2644	100 RB with RBstart=0	100 RB with RBstart=0
41	20	41310	2662	100 RB with RBstart=0	100 RB with RBstart=0
41	20	41490	2680	100 RB with RBstart=0	100 RB with RBstart=0

TABLE K-7 LTE INTERMEDIATE CHANNEL MEASUREMENTS TABLE

Band	Channel Bandwidth (MHz)	Channel	Frequency (MHz)	UL RB Allocation	DL RB Allocation
48	10	55290	3555	50 RB with RBstart=0	50 RB with RBstart=0
48	10	55380	3564	50 RB with RBstart=0	50 RB with RBstart=0
48	10	55470	3573	50 RB with RBstart=0	50 RB with RBstart=0
48	10	55560	3582	50 RB with RBstart=0	50 RB with RBstart=0
48	10	55650	3591	50 RB with RBstart=0	50 RB with RBstart=0
48	10	55740	3600	50 RB with RBstart=0	50 RB with RBstart=0
48	10	55830	3609	50 RB with RBstart=0	50 RB with RBstart=0
48	10	55910	3617	50 RB with RBstart=0	50 RB with RBstart=0
48	10	55990	3625	50 RB with RBstart=0	50 RB with RBstart=0
48	10	56070	3633	50 RB with RBstart=0	50 RB with RBstart=0
48	10	56150	3641	50 RB with RBstart=0	50 RB with RBstart=0
48	10	56240	3650	50 RB with RBstart=0	50 RB with RBstart=0
48	10	56330	3659	50 RB with RBstart=0	50 RB with RBstart=0
48	10	56420	3668	50 RB with RBstart=0	50 RB with RBstart=0
48	10	56510	3677	50 RB with RBstart=0	50 RB with RBstart=0
48	10	56600	3686	50 RB with RBstart=0	50 RB with RBstart=0
48	10	56690	3695	50 RB with RBstart=0	50 RB with RBstart=0
66 ²	10	66486	2115	50 RB with RBstart=0	50 RB with RBstart=0
66	10	66566	2123	50 RB with RBstart=0	50 RB with RBstart=0
66	10	66636	2130	50 RB with RBstart=0	50 RB with RBstart=0
66	10	66706	2137	50 RB with RBstart=0	50 RB with RBstart=0
66	10	66786	2145	50 RB with RBstart=0	50 RB with RBstart=0
66	10	66866	2153	50 RB with RBstart=0	50 RB with RBstart=0
66	10	66936	2160	50 RB with RBstart=0	50 RB with RBstart=0
66	10	67006	2167	50 RB with RBstart=0	50 RB with RBstart=0
66	10	67086	2175	50 RB with RBstart=0	50 RB with RBstart=0
71	10	68636	622	25 RB with RBstart=0	50 RB with RBstart=0
71	10	68706	629	25 RB with RBstart=0	50 RB with RBstart=0
71	10	68761	634.5	25 RB with RBstart=0	50 RB with RBstart=0
71	10	68816	640	25 RB with RBstart=0	50 RB with RBstart=0

TABLE K-7 LTE INTERMEDIATE CHANNEL MEASUREMENTS TABLE

Band	Channel Bandwidth (MHz)	Channel	Frequency (MHz)	UL RB Allocation	DL RB Allocation
71	10	68886	647	25 RB with RBstart=0	50 RB with RBstart=0
<p>Note 1: Note that if the device supports Band 25 and Band 2, then testing is only required to be completed in band 25. The test requirements and data comparison between Bands 2 and 25 will not be directly comparable due to the usage of different RF channel bandwidths.</p> <p>Note 2: Note that if the device supports Band 4 and Band 66, then testing is only required to be completed in band 66.</p> <p>Note 3: Note that if the device supports Band 26 and Band 5, then testing is only required to be completed in band 26. The test requirements and data comparison between Bands 26 and 5 will not be directly comparable due to the usage of different RF channel bandwidths.</p> <p>Note 4: Note that only A-GNSS ICD testing is required for Band 5. As there are no other intermediate channels, no LTE relative sensitivity testing is required.</p>					

Appendix L Notebook and Tablet Appendix (Normative)

L.1 Purpose

The purpose of this appendix is to define the CTIA Certification program test requirements for performing Radiated RF Power and Receiver Performance measurements on notebooks and tablets with embedded WWAN (Wireless Wide Area Network) radio modules.

L.2 Scope

The scope of this appendix is limited to specific setup and measurement criteria to be used when a notebook or tablet with an embedded WWAN radio is submitted to a ATL for RF Performance testing. All other equipment, equipment set up and test procedures documented in the CTIA Certification OTA Test Plan will apply.

L.3 Definitions

Notebook- A portable personal computer combining the computer, keyboard and display in one form factor. Typically the keyboard is built into the base and the display is hinged along the back edge of the base. A convertible notebook is a form factor that enables configuration as a notebook or as a tablet.

Tablet- A portable personal computer combining the computer and display in a single form factor resembling a writing slate. User input is typically accomplished via a touchscreen or stylus pen.

L.4 Equipment Under Test - Setup

The EUT shall be tested in an idle state and shall be configured as follows (as it applies). The manufacturer shall provide instructions to the ATL for placing the EUT in this state.

- Display:
 - Angled for a notebook
 - ⇒110 ±5° from the leveled base to the front of the display LCD (Liquid Crystal Display).
 - ⇒Or manufacturer's locked position closest to 110°.
 - Parallel to the X-Y plane for a tablet
- Transmitting radios:
 - WWAN - On
 - WLAN (Wireless Local Area Network)- Off
 - Bluetooth™ - Off
 - WiMAX™ - Off
 - UWB (Ultra Wideband)- Off

- All other embedded transmitting radios that are not being tested - Off
- Power Management Settings
 - Screensaver - None
 - Turn Off Display - Never
 - Turn Off Hard Drive - Never
 - System Hibernate - Never
 - System Standby - Never
- Display (LCD) Backlight - Medium intensity (50% or equivalent)
 - Ambient light sensor - Disabled
- Keyboard Backlight - Off
 - Ambient light sensor - Disabled
- Powered by the battery (standard battery only)
- Dynamic control or throttling of CPU and bus clock frequencies - Disabled, if possible.
 - May be accomplished via Microsoft® Windows power profile settings (e.g., Microsoft® XP “Always On” power scheme and Microsoft® Vista “Max Performance” power plan). The Microsoft® Windows power profile must not override the Power Management settings identified above (display, hard drive, etc.)
 - Device manufacturer to provide ATL with specific guidance
- As required, a user-configurable WWAN antenna will be positioned in accordance with the manufacturer's recommended configuration (See [Section 1.6](#) for further information).

L.5 Testing of Physically Reconfigurable Devices

Certain devices support usage in more than one physical configuration, such as convertible notebooks. Each configuration may produce different radiated performance due to possible changes in antenna performance and self-interference. Consequently, such devices may require testing in more than one configuration. At a minimum, the device shall be tested in the manufacturer's recommended configuration(s).

L.6 Notebooks and Tablets with Extendable/Retractable Antennas

Some retractable antennas used for embedded notebooks and tablets are functional only in the extended position. In such cases, the device shall only be tested with the antenna in the manufacturer's recommended configuration.

L.7 Multi-Protocol Devices

Embedded WWAN data modules commonly support multiple protocols or air interfaces (e.g. GPRS/EGPRS/UMTS) within the same frequency band. In cases where particular modes are not relevant to the intended use of the EUT, it is allowable to test only a subset of the supported protocols. The device manufacturer shall specify the intended use cases.

Note that these guidelines shall not preclude using the alternative single-point and multi-point offset test procedures for TIS and TRP described in the CTIA Certification OTA Test Plan. For example, in the event

that the manufacturer and operator agree that voice-mode results are not required for certification, the ATL may nevertheless opt to measure TIS and TRP in a voice mode to take advantage of the test time optimization provided by those alternative procedures. The manufacturer should be aware that certain protocols not required by the operator for certification may nonetheless be needed by the ATL and should be available on the device submitted for testing.

L.8 Free Space Testing

Since notebooks and tablets are not body-worn devices and they are not recommended for use placed directly on the lap, the EUT shall be tested in a Free Space configuration.

If a fixture is required to mount the EUT to the positioning system, the EUT holding fixture shall be made of a material with a dielectric constant of less than 5.0, and loss tangent less than 0.05. The fixture shall not extend beyond the footprint of the EUT by more than 20 mm, and shall be no more than 20 mm in thickness. It is recommended, but not required, that a Styrofoam spacer be used between the holding fixture and the EUT. For systems where no holding fixture is required, a spacer made of expanded polystyrene may be used to raise the EUT to the required height.

L.9 Chamber Placement

To minimize the physical volume occupied by the EUT during testing, the center of rotation shall be the three-dimensional geometric center of the EUT. In the case of an open notebook, this will typically be a point in space above the keyboard and in front of the display.

This section describes a suggested procedure to locate the geometric center of rotation for notebook and tablet form factors. This procedure has been verified to produce repeatable positioning within a margin of ± 10 mm in all dimensions. For distributed-axes systems, the procedure assumes the availability of a laser crosshair system in the chamber. The laser is required to have a vertical and horizontal beam such that the intersection of the beams passes through the origin of the chamber coordinate axes.

For combined-axes systems, laser guides are not required, since the pedestal assembly constrains the dimensions in which the EUT may be positioned. However, this procedure assumes that the range pedestal is properly aligned such that the phi and theta rotational axes intersect at a point in space precisely above the theta turntable hub. It also assumes that the rotational center of the theta turntable is clearly and precisely marked. Alignment of the EUT with the theta axis of the pedestal can be accomplished by means of a plumb line or laser level (capable of projecting a plumb line) placed on the turntable at its center of rotation.

L.9.1 Positioning a Notebook Relative to the Chamber Coordinate System

The reference plane for the EUT is defined as the plane on which the base of the EUT sits. This plane will be normal to the phi axis of the chamber.

Before placing the EUT in the chamber, place the notebook on a level surface and with the notebook open, with an angle of 110° between the LCD display and the level surface, locate and mark the points labeled A to H in [Figure L-1](#). Care should be taken to ensure that the display of the laptop does not move outside of the 110 degree ± 5 degree allowed limits. It may be necessary to fix the angle of the display

with RF transparent EPS (Expanded Polystyrene foam or Styrofoam), using the minimum amount necessary to perform the support function.

FIGURE L-1 POSITION OF NOTEBOOK RELATIVE TO THE CHAMBER COORDINATES

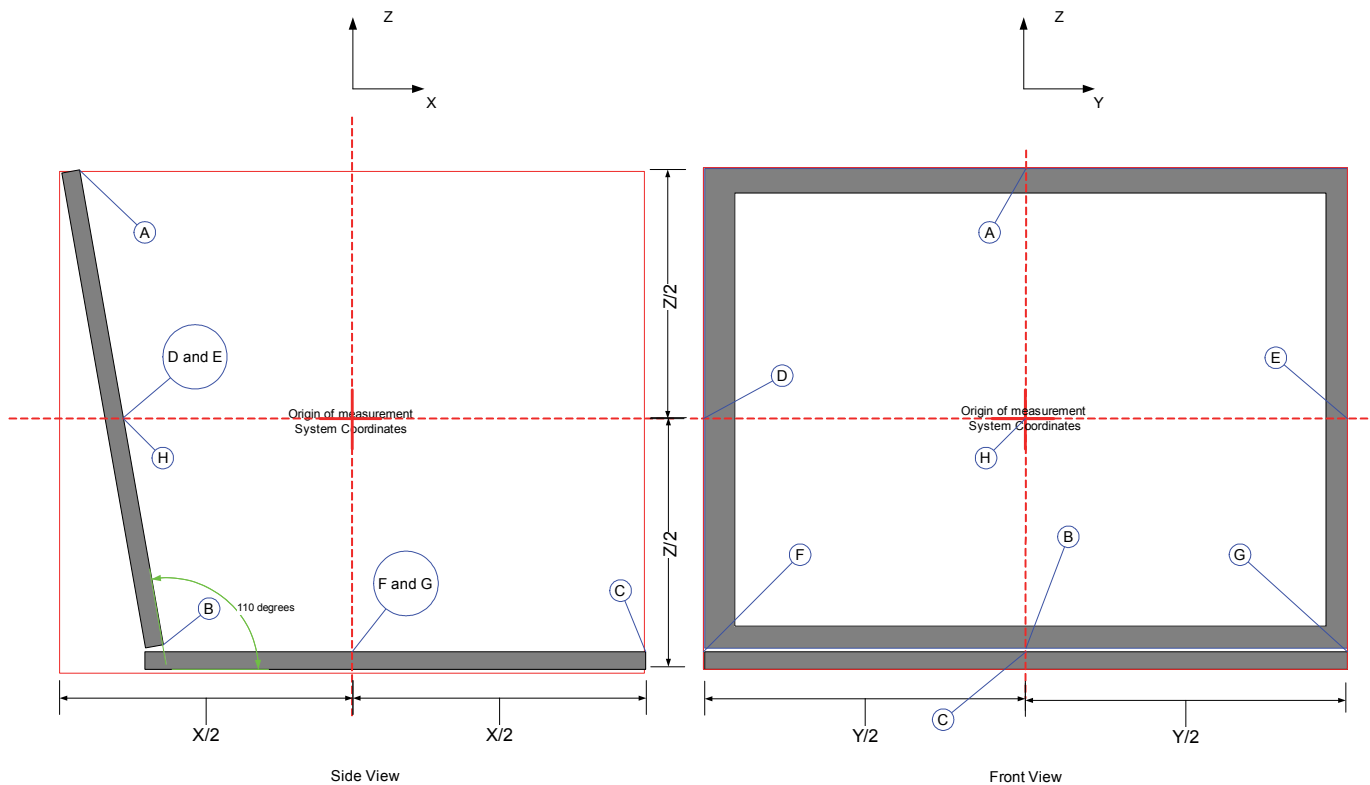

Point H is at the intersection of lines joining points A to B and D to E and is on the face of the LCD

L.9.1.1 Distributed Axes, Conical Cut Chamber

1. Place the notebook on the central plinth with the LCD, +X EUT axis, facing in the $\phi = 0^\circ$, $\theta = 0^\circ$ direction. With the assumption that the chamber laser crosshair system is directed in the $\phi = 270^\circ$, $\theta = 90^\circ$ direction, rotate the azimuth table to the $\phi = 270^\circ$ position. Adjust the height of the table so that the horizontal beam of the crosshairs intersects point H.
2. Adjust the position of the notebook along the EUT Y-axis so that the vertical laser beam intersects with points A, B, C and H.
3. Rotate the chamber azimuth table back to the $\phi = 0^\circ$ position and adjust the notebook along the EUT X-axis so that the vertical laser beam intersects points F and G. If necessary place an object behind the EUT at point F to observe the location of the vertical laser beam.

4. Rotate the azimuth table back to the $\phi = 270^\circ$ position and recheck the alignment. Repeat if necessary.

If the chamber laser crosshair system is orientated differently, adjust the above procedure appropriately.

L.9.1.2 Combined-Axes, Great Circle Chamber

1. Mount the notebook base on to the phi positioner such that the phi axis of rotation is centered at the intersection of the lines joining points B to C and F to G. With this intersection point clearly marked on the base of the notebook, it should be possible to accomplish this without any special aids.
2. Rotate the EUT about the phi axis until the notebook's X direction faces vertically downward (display facing down).
3. Adjust the pedestal along the phi axis until Point H is aligned with the theta axis, as verified by the plumb line or laser level. Any misalignment in the Y direction (theta axis does not intersect the line joining A to B) indicates inaccurate positioning about the phi axis.

L.9.2 Positioning a Tablet Relative to the Chamber Coordinate System

For tablet form factors, it is assumed that the display faces in the +Z direction and the +X direction points towards the expected user position. For example, [Figure L-2](#) illustrates this for a rectangular tablet with display configured to be used in the "portrait" orientation. Since this class of device often supports multiple display orientations, the manufacturer shall submit photographs or drawings to the ATL indicating the assumed EUT reference coordinate system. These illustrations shall also be included in the test report.

Before placing the EUT in the chamber locate and mark the points labeled A to K shown in [Figure L-2](#).

FIGURE L-2 POSITION OF TABLET RELATIVE TO THE CHAMBER COORDINATES

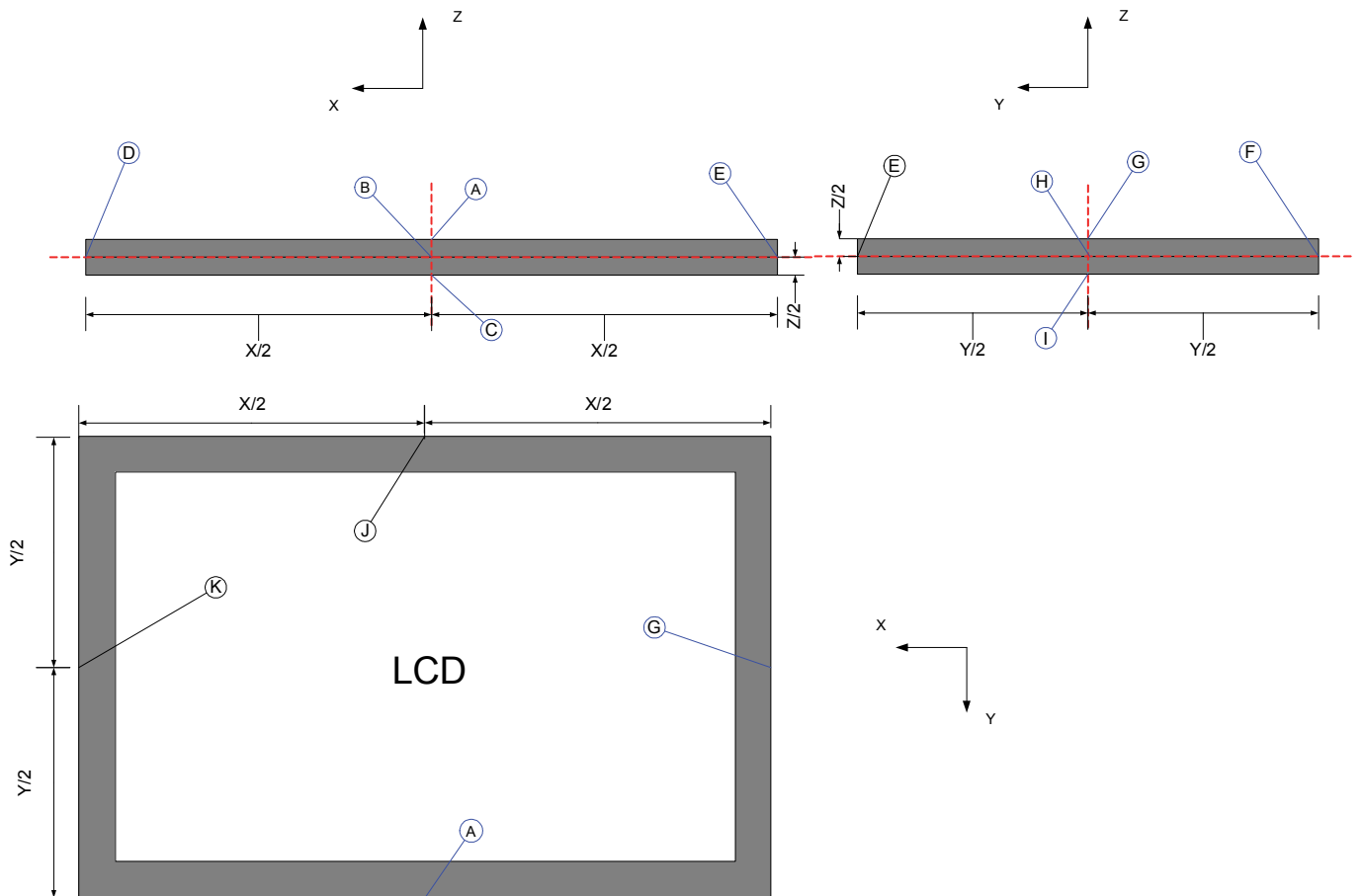

L.9.2.1 Distributed Axes, Conical Cut Chamber

1. Place the tablet on the central plinth with the +X EUT axis facing in the $\phi = 0^\circ$, $\theta = 0^\circ$ direction. With the assumption that the chamber laser crosshair system is directed in the $\phi = 270^\circ$, $\theta = 90^\circ$ direction, adjust the height of the tablet so that the horizontal beam of the crosshairs intersects point B.
2. Adjust the position of the tablet along the EUT X-axis so that the vertical laser beam intersects points A, B, C and J. If necessary place an object behind the EUT at point J to observe the location of the vertical laser beam.
3. Rotate the chamber azimuth table to the $\phi = 90^\circ$ position and adjust the tablet along the EUT Y-axis so that the vertical laser beam intersects points G, H, I and K. If necessary place an object behind the EUT at point K to observe the location of the vertical laser beam.

4. Rotate the azimuth table back to the 0° position and recheck the alignment. Repeat if necessary.

If the chamber laser crosshair system is orientated differently, adjust the above procedure appropriately.

L.9.2.2 Combined-Axis, Great Circle Chamber

1. Mount the EUT base on to the phi positioner such that the phi axis of rotation is centered at the intersection of the lines joining points A to J and G to K. With this intersection point clearly marked on the base of the tablet, it should be possible to accomplish this without any special aids.
2. Rotate the EUT about the phi axis until the tablet Y direction faces vertically downward.
3. Adjust the pedestal along the phi axis until Point B is aligned with the theta axis, as verified by the plumb line or laser level.
4. Rotate the EUT about the phi axis until the tablet X direction faces vertically upward.
5. Verify that Point H is aligned with the theta axis based on the plumb line or laser level. Any misalignment indicates inaccurate positioning about the phi axis.

L.9.3 Minimum Measurement Distance Considerations

Due to the large form factor of typical notebooks, the minimum measurement distance criteria, in particular, the $2D^2/\lambda_v$ limit specified in [Section 3.1](#) of the CTIA Certification OTA Test Plan cannot be satisfied on shorter ranges.

For devices with a largest single dimension D (i.e., length, width, height) ≤ 0.42 m, a measurement distance R , where $R \geq 1.2$ m, is acceptable for TRP, TIS and average gain measurements. However, an additional standard uncertainty value must be included in the total EUT measurement uncertainty calculation to account for the violation of the far field as identified in [Appendix G.19.1](#). Testing of devices with a largest single dimension $D > 0.42$ m is outside the scope of the guidance provided by this document.

Note that EM simulations indicate that the antenna current distribution for embedded WWAN platforms is not uniform over the EUT volume, but rather is highly localized along its outer edges adjacent to the antennas. Furthermore, the current distribution becomes more localized with increasing RF frequency. Consequently, the effective radiating aperture size D should be assumed equal to the largest single physical dimension of the EUT. For example, for a typical widescreen notebook computer, D is the width of the device, not the three-dimensional distance between one upper corner of the screen and the extreme opposite corner of the base.

L.10 Additional Measurement Uncertainty

L.10.1 Ripple Uncertainty

The ripple uncertainty associated with larger devices shall be determined as described in [Section 3.7](#) and [Appendix G.8](#) of the CTIA Certification OTA Test Plan, using data collected from the additional ripple test procedure for notebook-sized volumes defined in [Section 3.6](#).

L.10.2 Uncertainty Due to Minimum Measurement Distance

Please refer to [Appendix L.9.3](#) for guidance.

L.10.3 Additional Coarse Sampling Grid Uncertainty

The TIS measurement uncertainty associated with using a 30° pattern grid spacing is discussed in [Appendix G.12](#) of the CTIA Certification OTA Test Plan. It is conceivable that this source of uncertainty is worse for devices larger than the handset+head phantom combination for which this effect was originally assessed. Any additional uncertainty is only expected to occur with the largest “desktop replacement” notebooks, and remains a topic for further investigation.

Appendix M Optional GSM, UMTS and LTE Bands (Informative)

M.1 Optional Frequency Bands and Channel Configurations

The following GSM and UMTS bands/frequencies can be tested:

TABLE M-1 GSM FREQUENCY BANDS

Operating Band	UL Frequencies MS Transmit, BTS Receive (MHz)	DL Frequencies MS Receive, BTS Transmit (MHz)
P-GSM 900	890 - 915	935 - 960
E-GSM 900	880 - 915	925 - 960
DCS 1800	1710-1785	1805-1880

TABLE M-2 GSM CHANNELS

Operating Band	Channels		
	Low	Mid	High
P-GSM 900	1	62	124
E-GSM 900	975	38	124
DCS 1800	512	699	885

TABLE M-3 UMTS FREQUENCY BANDS

Operating Band	UL Frequencies UE transmit, Node B Receive (MHz)	DL Frequencies UE receive, Node B Transmit (MHz)
I	1920 - 1980	2110 -2170
III	1710-1785	1805-1880
VIII	880 - 915	925 - 960

TABLE M-4 UMTS CHANNELS

Operating Band	UL Channels			DL Channels		
	Low	Mid	High	Low	Mid	High
I	9612	9750	9888	10562	10700	10838
III	937	1113	1288	1162	1338	1513
VIII	2712	2788	2863	2937	3013	3088

TABLE M-5 LTE FREQUENCY BANDS

Operating Band	UL Frequencies, UE Transmit, eNodeB Receive (MHz)	DL Frequencies, UE Receive, eNodeB Transmit (MHz)
1	1920-1980	2110-2170
3	1710-1785	1805-1880
8	880-915	925-960
20	832-862	791-821
38	2570-2620	2570-2620
39	1880-1920	1880-1920
40	2300-2400	2300-2400

TABLE M-6 LTE TRP CHANNELS AND RB ALLOCATIONS

Band	Channel Bandwidth (MHz)	Channel	UL RB Allocation	DL RB Allocation
1 Low	10	18050	12 RB with RBstart=0	None, control only ¹
1 Mid	10	18300	12 RB with RBstart=19	None, control only ¹
1 High	10	18550	12 RB with RBstart=38	None, control only ¹
3 Low	10	19250	12 RB with RBstart=0	None, control only ¹
3 Mid	10	19575	12 RB with RBstart=19	None, control only ¹
3 High	10	19900	12 RB with RBstart=38	None, control only ¹
8 Low	10	21500	12 RB with RBstart=0	None, control only ¹
8 Mid	10	21625	12 RB with RBstart=19	None, control only ¹
8 High	10	21750	12 RB with RBstart=38	None, control only ¹
20 Low	10	24200	12 RB with RBstart=0	None, control only ¹
20 Mid	10	24300	12 RB with RBstart=19	None, control only ¹

TABLE M-6 LTE TRP CHANNELS AND RB ALLOCATIONS

Band	Channel Bandwidth (MHz)	Channel	UL RB Allocation	DL RB Allocation
20 High	10	24400	12 RB with RBstart=38	None, control only ¹
38 Low	20	37850	18 RB with RBstart=0	None, control only ¹
38 Mid	20	38000	18 RB with RBstart=41	None, control only ¹
38 High	20	38150	18 RB with RBstart=82	None, control only ¹
39 Low	20	38350	18 RB with RBstart=0	None, control only ¹
39 Mid	20	38450	18 RB with RBstart=41	None, control only ¹
39 High	20	38550	18 RB with RBstart=82	None, control only ¹
40 Low	20	38750	18 RB with RBstart=0	None, control only ¹
40 Mid	20	39150	18 RB with RBstart=41	None, control only ¹
40 High	20	39550	18 RB with RBstart=82	None, control only ¹

Note 1: As per 3GPP TS 36.521-1, Section 6.2 (UE Maximum Output Power).

TABLE M-7 LTE TIS CHANNELS AND RB ALLOCATIONS

Band	Channel Bandwidth (MHz)	Channel	UL RB Allocation	DL RB Allocation
1 Low	10	50	50 RB with RBstart=0	50 RB with RBstart=0
1 Mid	10	300	50 RB with RBstart=0	50 RB with RBstart=0
1 High	10	550	50 RB with RBstart=0	50 RB with RBstart=0
3 Low	10	1250	50 RB with RBstart=0	50 RB with RBstart=0
3 Mid	10	1575	50 RB with RBstart=0	50 RB with RBstart=0
3 High	10	1900	50 RB with RBstart=0	50 RB with RBstart=0
8 Low	10	3500	25 RB with RBstart=25	50 RB with RBstart=0
8 Mid	10	3625	25 RB with RBstart=25	50 RB with RBstart=0
8 High	10	3750	25 RB with RBstart=25	50 RB with RBstart=0
20 Low	10	6200	20 RB with RBstart=0	50 RB with RBstart=0
20 Mid	10	6300	20 RB with RBstart=0	50 RB with RBstart=0
20 High	10	6400	20 RB with RBstart=0	50 RB with RBstart=0
38 Low	20	37850	100 RB with RBstart=0	100 RB with RBstart=0
38 Mid	20	38000	100 RB with RBstart=0	100 RB with RBstart=0
38 High	20	38150	100 RB with RBstart=0	100 RB with RBstart=0
39 Low	20	38350	100 RB with RBstart=0	100 RB with RBstart=0
39 Mid	20	38450	100 RB with RBstart=0	100 RB with RBstart=0
39 High	20	38550	100 RB with RBstart=0	100 RB with RBstart=0

TABLE M-7 LTE TIS CHANNELS AND RB ALLOCATIONS

Band	Channel Bandwidth (MHz)	Channel	UL RB Allocation	DL RB Allocation
40 Low	20	38750	100 RB with RBstart=0	100 RB with RBstart=0
40 Mid	20	39150	100 RB with RBstart=0	100 RB with RBstart=0
40 High	20	39550	100 RB with RBstart=0	100 RB with RBstart=0

All test parameter settings as specified in [Section 5](#) and [Section 6](#) shall be used where applicable. The following items are not required for these bands:

- Ripple tests
- Measurement uncertainty limits
- Intermediate channel testing
- GPRS/EDGE measurements
- A-GNSS measurements

Some test configurations may be excluded.

As noted, measurement uncertainty limits will not be required, because ripple testing is not required. However, measurement uncertainty calculations can be provided as an estimation using MU values from the closest frequency band where full MU assessment is required.

M.2 Considerations in Measurements of TRP for LTE TDD UEs

The contents of this section are no longer needed since they have been incorporated in [Appendix D.9](#) in V3.3.

M.3 Requirements for Measurement of Optional LTE Channel Bandwidths

The contents of this section are no longer needed since they have been incorporated in [Appendix D.9](#) in V3.3.

Appendix N Path Loss Errors Induced by Propagation Delay (Informative)

N.1 Description and Overview

Most traditional Network Analyzer (either Scalar or Vector) and Spectrum Analyzer / Tracking Generator measurements are made with short cables. In an OTA chamber there is significant propagation delay from the source to the receiver, due to the long cable lengths as well as the over-the-air path length. When swept measurements are made, by the time the signal travels from the source to the receiver, the instrument will be tuned to a higher frequency. This will result in an amplitude error that is a product of the [generally Gaussian] bandwidth filter response curve in (dB/Hz), the sweep rate in (Hz/s), and the propagation delay in (s).

There may be additional factors for particular instruments due to settling time issues if the synthesizer re-locks, or if the instrument performs other housekeeping, during the sweep.

Although list-based network analyzer measurements theoretically ought not exhibit this same phenomenon, propagation delay error is still possible depending on the combination of cable length, path loss length, instrument bandwidth, instrument settling time and instrument sampling time.

In general, the means of mitigating this problem for swept-based measurements is to slow down the sweep speed. In general, the means of mitigating this problem for list-based measurements is to delay the measurement sampling time (which may require an increase in the dwell time).

Discrete signal generator and receiver combinations are not subject to this phenomenon. As such, this discrete topology provides the most accurate verification for swept and list-based instrument configurations.

N.2 Verification Principles

Problems with swept measurements can typically be identified by slowing the sweep speed and watching for an increase in the measured signal (reduction in path loss). Depending on the particular instrument's coupling between IF Bandwidth and Sweep Time, reducing the IF Bandwidth may be used to identify this phenomenon. The result can assumed to be valid when further adjustment of the settings causes no further increase in the measured signal level.

Problems with list-based measurements can typically be identified by delaying the measurement sampling time and watching for an increase in the measured signal (reduction in path loss). The result can assumed to be valid when further adjustment of the settings causes no further increase in the measured signal level.

For both swept and list-based measurements the result is determined to be valid when the path loss at a given frequency when measured in the swept or list mode and the path loss at the same frequency when measured in the CW mode are within the repeatability of the instrumentation.

N.3 CW Verification Procedure

A set of CW measurements is made and compared to the automated swept or list-based measurements. The CW tests specifically utilize the procedures described in [Section 4.4.1](#) step 4.c. and [Section 4.4.2](#) step 5. c. The respective steps a. and b. of these clauses describe vector and scalar measurement procedures.

For instrument sweeps or spans that encompass multiple dipole frequencies, it is recommended that CW measurements be performed at the center frequency of each of three reference dipoles (the lowest frequency dipole, the dipole nearest the mid-frequency of the sweep and the highest frequency dipole). For instrument sweeps or spans that encompass only one dipole frequency range, it is recommended that CW measurements be performed at the low, center and high frequencies of the dipole.

The CW measurements are performed in one configuration then compared with the results of the corresponding swept or list-based measurement(s) in the same configuration. Following are relevant conditions:

- The overall cable lengths for all configurations (combination of theta/phi polarization and TRP/TIS path) are approximately the same.
- The CW measurements utilize the same instrument settings as the swept or list-based measurements.
- The CW measurements use the same type of Calibration (Normalization / Full 2-port, etc. as chosen) as the swept or list-based measurements.
- The CW measurements are performed manually and the swept or list-based measurements are performed either manually or with the system software (as chosen).

If there is a significant difference in the various (theta/phi/TRP/TIS) path lengths then it is recommended to make measurements over the longest path; shorter lengths can be considered for additional verification.

Generally, verification only needs to be performed once for a particular combination of chamber model, coax cable length, instrument model and instrument settings.

Appendix O Recommended Use Cases and Special Test Requirements (Informative)

O.1 Purpose

The purpose of this appendix is to recommend test applicability by device type and define special test requirements.

This appendix is written in a normative context, but all or portions of the text may be considered normative or informative based on the certification body that incorporates the test plan.

O.2 Definitions

Integrated Device- A device that embeds a Module. Notebook computers and tablets are special categories of integrated devices and are additionally defined in [Appendix L.3](#).

Integration Component- A device that meets the definition of an Integrated Device but is intended to be completely self-contained and incorporated “into” or “part of” a “Host Product” without any electrical interaction with the host product.

Module- A finished WWAN radio device that does not directly connect to a host via a standardized external interface such as PCMCIA, RS-232, USB, PCIExpress, etc.

Target Operator- An operator is considered a “target operator” for a device if either of the following criteria is satisfied:

- The device is sold through the operator's supply chain (e.g. operator store, operator online website, etc.). **Note:** *The device may also be sold through other outlets in addition to the operator's supply chain; and/or*
- The device is expected to access an operator's network where that operator requires OTA testing before the device is allowed to access the operator's network. **Note:** *An operator may waive off some aspects of OTA testing or OTA testing in its entirety, in which case this clause does not apply.*

If neither of these criteria is satisfied, then the device is considered to have no “target operator”.

USB Modem- A modem that plugs into the USB port of a computer. Its primary use case is while directly connected to the computer without the need for additional cabling.

O.3 Testing Required-Head and Hand Phantom, and Free-Space Test Conditions

This section applies to following type of devices:

- Devices supporting usage against the head

The following rules determine which types of devices will be tested for which mechanical modes, which test conditions, which cellular radio modes and which channels.

- If a device has multiple mechanical modes in which to make a voice call, each mechanical mode representative of end use, where the receiver is placed on the ear, shall be tested (e.g., a portrait slide phone shall be tested in both slide open and slide closed positions, a side slide phone shall be tested only in the slide closed position, a fold phone shall be tested only in the open position). Device mechanical modes that are not representative of end use do not need to be tested in head and hand phantom, and free-space test conditions.

The vendor shall submit to the ATL a declaration of the primary mechanical mode as referenced in this test plan. The ATL shall use the primary mechanical mode when applying the pass/fail limits.

- In the free-space test condition, all cellular radio modes capable of voice and data operation shall be tested for all the mechanical modes representative of end use. In the head-adjacent test conditions, all cellular radio modes capable of voice operation shall be tested for all the mechanical modes representative of end use. In the case of cellular data modes in the head-adjacent test conditions, these radio modes would be tested only if the device, as manufactured, supports voice operation over the data connection (e.g., VoIP).
- Testing in non-primary mechanical modes is only required on the middle channel; low and high-channel testing is not required. Note that for intermediate channel testing of non-primary mechanical modes, the middle channel is used as the reference channel for all intermediate channel tests because TIS is not tested at the low and high channels.
- Devices that exceed the maximum dimensions specified for the hand phantom test conditions defined in this test plan do not need to be tested in the head and hand phantom test conditions.
- For LTE, UMTS, GSM, and CDMA, TRP and TIS testing across the entire band is required for FS, BHHR, and HL. For UMTS, CDMA, and GSM, BHHL and HR testing is not required. For LTE, only mid-channel testing is required for BHHL and HR for TRP and TIS (i.e. no low/high channel testing is required for BHHL and HR unless requested by the manufacturer). Note: This paragraph does not apply to A-GNSS OTA testing.
- A-GNSS OTA testing is, in general, not required in the free-space test conditions as specified in this test plan. BHHL, BHHR, HL, and HR are required for A-GNSS OTA testing.
- For devices that support both LTE operation against the head (e.g., VoIP) and LTE carrier aggregation, head-adjacent testing is only required in LTE standalone mode. Head-adjacent testing is not required in LTE carrier aggregation mode for these devices. Hand-only testing is required in both LTE standalone mode and LTE carrier aggregation mode for these devices. Per [Table O-1](#) below, full TRP and TIS testing across the entire band is required for HL per the table below; and only mid-channel testing is required for HR for TRP and TIS (i.e., no low/high channel testing is required for HR unless requested by the manufacturer).

TABLE O-1 CA TEST REDUCTION TABLE

PCC Test Channel ¹	HL		HR	
	TRP	TIS	TRP	TIS
Low Channel	PCC	PCC/SCC(s) ^{1,2}	Optional ³	Optional ³
Mid Channel	PCC	PCC/SCC(s) ^{1,2}	PCC ⁴	PCC/SCC(s) ^{1,2,5}
High Channel	PCC	PCC/SCC(s) ^{1,2}	Optional ³	Optional ³

Note 1: PCC and SCC test channels are per [Table 5-30](#), [Table 5-32](#), [Table 6-25](#) and [Table 6-27](#).
Note 2: Testing is required on the PCC and all SCC's unless indicated otherwise in [Appendix O.8](#).
Note 3: Not required unless requested by the manufacturer.
Note 4: For bands which only support one channel (e.g. bands 13, 30), the mid-channel TRP test point for HR shall be the TRP test point with the mid-channel uplink RB allocation.
Note 5: For bands which only support one channel (e.g. bands 13, 30), the mid-channel TIS test point for HR shall be the TIS test point where the SCC/SCC1 is mid-band.

- CDMA 1xEV-DO and CDMA 1xRTT DATA OTA (TRP/TIS/relative sensitivity on intermediate channels) testing is not required for CDMA devices that support voice operation against the head.
- CDMA 1xRTT data intermediate channel tests are not required if intermediate channel tests are passed in CDMA for the same frequency bands.
- CDMA 1xEV-DO intermediate channel tests are not required if intermediate channel tests are passed in CDMA or CDMA 1x RTT data for the same frequency bands.
- For CDMA devices that support voice operation against the head that meet the following conditions, CDMA OTA testing may be reduced.
 - The device supports LTE, and is fully tested (all use cases - FS, BHHR, HL) in the equivalent LTE band (including bands with wider frequency coverage, e.g. LTE 2 or 25 for CDMA BC1) as CDMA.
 - Each TX antenna for CDMA is the same as a TX antenna that was fully tested for LTE.
 - Each RX antenna for CDMA is the same as a RX antenna that was fully tested for LTE.
- Under these conditions, the CDMA OTA testing may be reduced as follows:
 - Test CDMA TRP/TIS in the mid-channel for only the following use cases: FS and BHHR.
 - Test CDMA relative sensitivity tests on intermediate channels only in BHHR. Note that the middle channel is used as the reference channel for all intermediate channel tests because TIS is not tested at the low and high channels.
- GPRS and EGPRS OTA (TRP/TIS/relative sensitivity on intermediate channels) testing is not required for GSM devices that support voice operation against the head.
- Relative sensitivity tests on intermediate channels in GPRS and EGPRS are not required if GSM is supported for the same frequency bands.
- GSM relative sensitivity tests on intermediate channels are not required for GSM devices that support voice operation against the head.
- For GSM devices that support voice operation against the head that meet the following conditions, GSM OTA testing may be reduced.

- The device supports LTE, and is fully tested (all use cases - FS, BHHR, HL) in the equivalent LTE band (including bands with wider frequency coverage, e.g. LTE 2 or 25 for GSM 1900) as GSM.
- Each TX antenna for GSM is the same as a TX antenna that was fully tested for LTE.
- Each RX antenna for GSM is the same as a RX antenna that was fully tested for LTE.
- Under these conditions, the GSM TRP/TIS testing may be reduced as follows:
 - Test GSM TRP/TIS in low, mid and high channels only in FS, except for non-primary mechanical modes where only the middle channel is tested in FS.
- UMTS OTA testing may be reduced for devices which meet the following criteria:
 - The device supports LTE, and is fully tested (all relevant use cases - FS, BHHR, HL) in the equivalent LTE band as UMTS.
 - Each TX antenna for UMTS is the same as a TX antenna that was fully tested for LTE.
 - Each RX antenna for UMTS is the same as a RX antenna that was fully tested for LTE.
- Under these conditions, UMTS OTA testing may be reduced as follows:
 - Test UMTS TRP/TIS (low, mid, high channel) for only the BHHR use case.
 - No relative sensitivity testing on intermediate channels is required,

O.4 Testing Required - Hand Phantom Test Conditions

This section applies to following types of devices:

- Devices supporting data usage in the hand phantom test conditions (devices that also support usage against the head shall also be tested per Appendix O.3 of this document)

The following rules determine which types of devices will be tested for which mechanical modes, which test conditions, which cellular radio modes and which channels.

- If a device has multiple mechanical modes in which it can be held in the hand for data usage scenarios where the display is visible to the end user, each mechanical mode representative of end use shall be tested. Device mechanical modes that are not representative of end use in the hand for data usage scenarios, do not need to be tested in the hand phantom test conditions. The vendor shall submit to the ATL a declaration of the primary mechanical mode as referenced in this test plan. The ATL shall use the primary mechanical mode when applying the pass/fail limits.
- In the hand phantom test conditions, all cellular radio modes capable of voice and data operation shall be tested for all the mechanical modes representative of end use.
- Testing in non-primary mechanical modes is only required on the middle channel; low- and high-channel testing is not required. Note that for intermediate channel testing of non-primary mechanical modes, the middle channel is used as the reference channel for all intermediate channel tests because TIS is not tested at the low and high channels.
- Devices that exceed the maximum dimensions specified for the hand phantom test conditions defined in this test plan do not need to be tested in the hand phantom test conditions.
- For devices that support voice operation against the head, LTE, UMTS, GSM, and CDMA TRP and TIS testing across the entire band is required for HL. For UMTS, CDMA, and GSM, HR testing is not required. For LTE, only mid-channel testing is required for HR for

- TRP and TIS (i.e. no low/high channel testing is required for HR unless requested by the manufacturer). Note: This paragraph does not apply to A-GNSS OTA testing.
- CDMA 1xEV-DO and CDMA 1xRTT DATA OTA (TRP/TIS/relative sensitivity on intermediate channels) testing is not required for CDMA devices that support voice operation against the head.
 - CDMA 1xRTT data intermediate channel tests are not required if intermediate channel tests are passed in CDMA for the same frequency bands.
 - CDMA 1xEV-DO intermediate channel tests are not required if intermediate channel tests are passed in CDMA or CDMA 1x RTT data for the same frequency bands.
 - For CDMA devices that support voice operation against the head that meet the following conditions, CDMA OTA testing may be reduced.
 - The device supports LTE, and is fully tested (all use cases - FS, BHHR, HL) in the equivalent LTE band (including bands with wider frequency coverage, e.g. LTE 2 or 25 for CDMA BC1) as CDMA.
 - Each TX antenna for CDMA is the same as a TX antenna that was fully tested for LTE.
 - Each RX antenna for CDMA is the same as a RX antenna that was fully tested for LTE.
 - Under these conditions, the CDMA OTA testing may be reduced as follows:
 - No CDMA OTA (TRP/TIS/relative sensitivity on intermediate channels) testing in HR and HL is required.
 - GSM OTA (TRP/TIS/relative sensitivity on intermediate channels) testing for HR/HL is not required for GSM devices that support voice operation against the head.
 - Relative sensitivity tests on intermediate channels in GPRS and EGPRS are not required if GSM is supported for the same frequency bands.
 - GSM relative sensitivity tests on intermediate channels are not required for GSM devices that support voice operation against the head.
 - GPRS and EGPRS OTA (TRP/TIS/relative sensitivity on intermediate channels) testing is not required for GSM devices that support voice operation against the head.
 - UMTS OTA testing may be reduced for devices which meet the following criteria:
 - The device supports LTE, and is fully tested (all relevant use cases - FS, BHHR, HL) in the equivalent LTE band as UMTS.
 - Each TX antenna for UMTS is the same as a TX antenna that was fully tested for LTE.
 - Each RX antenna for UMTS is the same as a RX antenna that was fully tested for LTE.
 - Under these conditions, the UMTS OTA testing may be reduced as follows:
 - No UMTS OTA (TRP/TIS/relative sensitivity on intermediate channels) testing in HR and HL is required.

O.5 Testing Required—Free-Space Only

Radiated performance testing of certain integrated devices that do not meet the criteria in [Appendix O.3](#) and [Appendix O.4](#) is limited to free-space only. The applicability of free-space testing is summarized by [Table O-2](#) and [Table O-3](#) below:

TABLE O-2 DATA-ONLY INTEGRATED DEVICE RADIATED TEST APPLICABILITY

Data-Only Integrated Device (no Circuit-Switched Voice or VoLTE Support)	Applicable Notes
Integrated, Non-Removable Antenna	See Notes 1, 2, 3 and 4
Removable Antenna Physically Attached to Device	See Notes 1, 2, 3 and 4
Removable Antenna Connected to Device via Transmission line less than 20 cm	See Notes 1, 2, 3 and 4

TABLE O-3 CIRCUIT-SWITCHED VOICE OR VoLTE-CAPABLE INTEGRATED DEVICE RADIATED TEST APPLICABILITY

Circuit-Switched Voice or VoLTE-Capable Integrated Device	Applicable Notes
Integrated, Non-Removable Antenna	See Notes 1, 2 and 4
Removable Antenna Physically Attached to Device	See Notes 1, 2 and 4
Removable Antenna Connected to Device via Transmission line less than 20 cm	See Notes 1, 2 and 4

Note 1: Physically large devices that do not meet the device size requirements in [Appendix P](#) or heavy devices that cannot be placed in an OTA chamber are excluded.

Note 2: Some devices include sensors which reduce the transmitter's RF output power when in close proximity to the user. TRP measurements of any device that includes user proximity RF power reduction shall be made when the proximity sensor is not activated (e.g. device is operating at full RF output power). The PTCRB lab shall also measure the device's RF output power when the proximity sensor is activated. This measurement may be made using either conducted or radiated techniques, and the lab shall document the proximity sensor's RF power reduction in dB.

Note 3: WWAN radiated performance testing of data-only devices (no support for voice nor VoLTE) shall be executed on every band supported. In addition, radiated performance testing of data-only devices shall be executed for every cellular radio mode supported according to [Table O-4](#) below.

Note 4: A-GNSS OTA testing is required in the free-space configurations as specified in this test plan in [Appendix P](#). Also, the vendor shall submit to the ATL a declaration of the primary mechanical mode as referenced in this test plan. The ATL shall use the primary mechanical mode when applying the pass/fail limits.

TABLE O-4 CELLULAR RADIO MODE TEST REQUIREMENTS FOR DATA-ONLY DEVICES

Cellular Radio Modes Supported by EUT	Cellular Radio Modes Subject to Radiated Performance Testing
GPRS, EGPRS, UMTS, LTE (not VoLTE-capable)	UMTS, LTE
EGPRS, UMTS, LTE (not VoLTE-capable)	UMTS, LTE
UMTS, LTE (not VoLTE-capable)	UMTS, LTE
GPRS, UMTS, LTE (not VoLTE-capable)	UMTS, LTE
GPRS, EGPRS, UMTS	EGPRS, UMTS
EGPRS, LTE (not VoLTE-capable)	EGPRS, LTE
EGPRS, UMTS	EGPRS, UMTS
GPRS, EGPRS	GPRS, EGPRS
1xRTT Data, 1xEV-DO	1xEV-DO
1xRTT Data, 1xEV-DO, LTE (not VoLTE-capable)	1xEV-DO, LTE

O.6 Testing Required—Wrist-Worn Test Conditions

This section applies to following types of devices:

- Devices supporting usage on the wrist

The following rules determine which types of devices will be tested for which mechanical modes, which test conditions, which cellular radio modes and which channels.

- The manufacturer shall declare the wristband to be used during the testing. The wristband to be used shall be the wristband packaged with the end product. If wristbands are provided separately, the wristband selection shall be based on the expected worst-case wristband.
- The manufacturer shall declare the housing material to be used during the test based on the expected worst-case material.
- If a device has multiple mechanical modes in which it can be used, each mechanical mode representative of end use shall be tested. Device mechanical modes that are not representative of end use while worn on the wrist, do not need to be tested in the forearm phantom test conditions. The vendor shall submit to the ATL a declaration of the primary mechanical mode as referenced in this test plan. The ATL shall use the primary mechanical mode when applying the pass/fail limits.
- Wrist worn devices shall only be tested in the wrist worn configuration using the Forearm Phantom defined in Appendix Q.5 and not in the free space condition.
- The manufacturer shall declare the single arm orientation (WL or WR) for test, based on the expected worst-case orientation and based on input from target operators.
- It is not necessary to measure nor report the following quantities for wrist worn devices: NHPRP, NHPIS, UHIS, nor PIGS, primarily because the orientation of the wrist worn device varies so much in normal usage that these partial quantities don't have much

- bearing on the user experience. Note that while UHIS measurements are not required, measurements at the peak in the upper hemisphere pattern will still be used instead of the peak in the entire pattern in order to avoid complicating the test implementation.
- Relative sensitivity on intermediate channel testing shall be performed on the single arm orientation (WL or WR) declared by the manufacturer.
 - In the forearm phantom test conditions, all LTE, LTE Cat-M1 and A-GNSS for LTE modes shall be tested for all the mechanical modes representative of end use.
 - Testing in non-primary mechanical modes is only required on the middle channel; low and high-channel testing is not required. Note that for intermediate channel testing of non-primary mechanical modes, the middle channel is used as the reference channel for all intermediate channel tests because TIS is not tested at the low and high channels.

O.7 Testing Not Required

This section applies to following types of devices:

- Integrated devices without a defined antenna and not meeting the criteria in [Appendix O.3](#) and [Appendix O.4](#) above.
- Integrated devices with a removable antenna that is connected to the device through an RF transmission line (such as a coaxial cable) greater than 20 cm in length and not physically attached to the host device and not meeting the criteria in [Appendix O.3](#) and [Appendix O.4](#) above. The no-testing-required justification document noted above shall include a vendor-provided list of recommended external antennas. The vendor shall also include this list in the product user manual.
- Modules
- PCMCIA cards and ExpressCards
- USB Modems
- Variants or re-branded devices having no altered RF performance from their parent device

Note: *The vendor shall consult with the carrier(s) to which it intends to sell the device to determine whether carrier-specific testing may be required. If no testing is conducted, the lab shall provide a detailed justification document stating that the device falls into one of the categories listed above.*

O.8 LTE CA and LAA Test Requirements

When submitting a device for CA and LAA testing, the device manufacturer shall declare the target operator(s) for the device, and the LTE CA and LAA testing shall be limited as described in [O.8.1](#), [O.8.2](#), and [O.8.3](#).

The operator CA and LAA priority list (v3.9.x Operator Priority List.xlsx) can be downloaded from <https://ctiacertification.org/test-plans/>.

O.8.1 LTE CA TRP Test Requirements

Full TRP testing is required in the 2 DL and 3 DL CA combinations identified as high priority combinations by the operator CA priority lists for all of the target operators for the UE under test. Single point offset testing shall not be used for high priority combinations.

TRP testing is required in the 2 DL and 3 DL CA combinations identified as high priority combinations and secondary priority combinations by the operator CA priority lists for all of the target operators for the UE under test. Single point offset testing may be used for secondary priority combinations. However, if a single point offset test results in a TRP value that deviates more than 2 dB from the TRP of the fully tested reference, then a full TRP measurement is required.

No additional TRP testing is required.

O.8.2 LTE CA TIS Test Requirements

Full TIS testing of the SCC is required for any CA combinations with known self-desense issues that are identified as “Essential” in the operator CA priority lists and are supported on the device (no TIS testing of the PCC is required). Single point offset testing shall not be used for CA combinations with known self-desense issues that are identified as “Essential” in the operator CA priority lists.

TIS testing (PCC and all SCC's) is required in the 2 DL and 3 DL CA combinations identified as high priority combinations and secondary priority combinations by the operator CA priority lists for all of the target operators for the UE under test. Single point offset testing may be used for both high priority and secondary priority combinations. However, if a single point offset test results in a TIS value that deviates more than 3 dB from the TIS of the fully tested reference, then a full TIS measurement is required.

No additional TIS testing is required.

O.8.3 LTE LAA TIS Test Requirements

Full TIS testing is required on Band 46 for one 2 CC LAA combination as defined by the logic below.

Band 46 radiated sensitivity performance for all other 2 CC and 3 CC LAA combinations that are identified by the operator LAA priority lists for all of the target operators for the UE under test shall be evaluated using the LAA Un-Licensed Degradation Test defined in [Section 6.21](#).

No additional Band 46 TIS testing is required.

FIGURE O-1 LOGIC FOR DETERMINING THE LAA COMBINATION USED FOR FULL TIS TESTING OF BAND 46

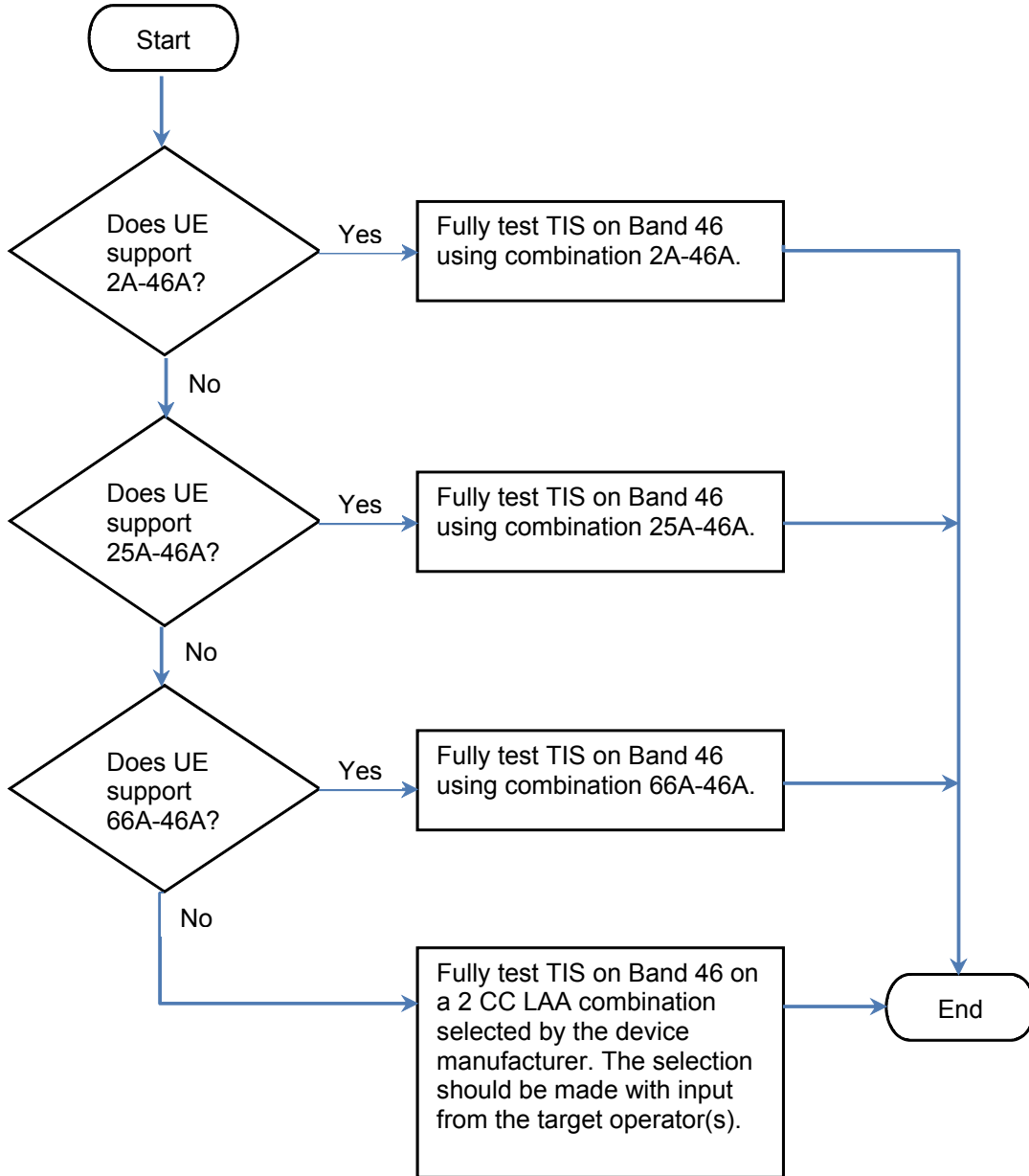

O.9 CatM1 and Cat-NB1 OTA Test Applicability

Cat-M1 and Cat-NB1 device vendors should consult the target operator(s) prior to device submission. If Cat-M1 and/or Cat NB1 TRP and TIS testing is required by the target operator(s), the device vendor shall provide specific information concerning the frequency bands, cellular radio mode and mechanical use cases to be evaluated when submitting the device for testing.

If the Cat-M1 and/or Cat-NB1 device is not targeted for a specific operator(s), then perform testing as follows:

- If Cat-M1 is supported, then free-space TRP/TIS testing shall be executed in all supported bands included in the list below:
 - Band 4
 - Band 5
 - Band 12
 - Band 13

Note: If Cat-M1 and Cat-NB1 are both supported in one or more bands, then Cat-M1 testing is the only cellular radio mode required in the supported bands.

- If Cat-NB1 is supported, then free-space TRP/TIS testing shall be executed in all supported bands included in the list below unless otherwise noted:
 - Band 4
 - Band 5
 - Band 12
 - Band 13
 - Band 66

Note: If Bands 4 and 66 are supported in Cat-NB1, then testing shall be executed in Band 66; Band 4 testing is not required in this case.

O.10 Special Test Requirements

O.10.1 LTE Relative Sensitivity on Intermediate Channels Test

Until such time that free-space limits are added for LTE TIS, the relative sensitivity on intermediate channels testing process shall be modified to report the FS $EIS_{(IC)}$, BHR $EIS_{(IC)}$, and WL/WR $EIS_{(IC)}$, if applicable, at each LTE Intermediate Channel test channel (including the reference test channels) as defined in [Appendix K.4](#). FS $EIS_{(IC)}$, BHR $EIS_{(IC)}$, and WL/WR $EIS_{(IC)}$, are equivalent to FS $EIS_{(peak)}$, BHR $EIS_{(peak)}$, and WL/WR $EIS_{(peak)}$, respectively, for the reference channels. Please refer to the relative sensitivity testing process in [Section 6.8.2](#) for a general definition of FS $EIS_{(peak)}$, BHR $EIS_{(peak)}$, and WL/WR $EIS_{(peak)}$. The same position and polarization shall be used for the intermediate

channels as used for the corresponding reference channels. If the optional full TIS method was used at an intermediate channel, the EIS value obtained from the full TIS measurement associated with the peak position and polarization for the closest reference channel shall be reported. The results shall be reported using the following template. The full TIS results at the intermediate channels may be included as additional data and marked as supplemental in the test report.

TABLE O-5 LTE RELATIVE SENSITIVITY ON INTERMEDIATE CHANNELS

Band	Channel Bandwidth (MHz)	Channel	Frequency (MHz)	FS EIS _(IC) (dBm)	BHHR EIS _(IC) (dBm)	WL/WR EIS _(IC) (dBm)
2	10	650	1935			
2	10	740	1944			
2	10	820	1952			
2	10	900	1960			
2	10	980	1968			
2	10	1060	1976			
2	10	1150	1985			
4	10	2000	2115			
4	10	2090	2124			
4	10	2175	2132.5			
4	10	2260	2141			
4	10	2350	2150			
12	5	5035	731.5			
12	5	5065	734.5			
12	5	5095	737.5			
12	5	5125	740.5			
12	5	5155	743.5			
25	5	8065	1932.5			
25	5	8105	1936.5			
25	5	8145	1940.5			
25	5	8185	1944.5			
25	5	8225	1948.5			
25	5	8265	1952.5			
25	5	8305	1956.5			
25	5	8345	1960.5			
25	5	8365	1962.5			
25	5	8385	1964.5			
25	5	8425	1968.5			
25	5	8465	1972.5			
25	5	8505	1976.5			
25	5	8545	1980.5			

TABLE O-5 LTE RELATIVE SENSITIVITY ON INTERMEDIATE CHANNELS

Band	Channel Bandwidth (MHz)	Channel	Frequency (MHz)	FS EIS _(IC) (dBm)	BHHR EIS _(IC) (dBm)	WL/WR EIS _(IC) (dBm)
25	5	8585	1984.5			
25	5	8625	1988.5			
25	5	8665	1992.5			
26	5	8715	861.5			
26	5	8755	865.5			
26	5	8795	869.5			
26	5	8835	873.5			
26	5	8865	876.5			
26	5	8895	879.5			
26	5	8935	883.5			
26	5	8975	887.5			
26	5	9015	891.5			
7	20	2850	2630			
7	20	2975	2642.5			
7	20	3100	2655			
7	20	3225	2667.5			
7	20	3350	2680			
41	20	39750	2506			
41	20	39930	2524			
41	20	40110	2542			
41	20	40280	2559			
41	20	40450	2576			
41	20	40620	2593			
41	20	40790	2610			
41	20	40960	2627			
41	20	41130	2644			
41	20	41310	2662			
41	20	41490	2680			
48	10	55290	3555			
48	10	55380	3564			
48	10	55470	3573			
48	10	55560	3582			
48	10	55650	3591			
48	10	55740	3600			
48	10	55830	3609			

TABLE O-5 LTE RELATIVE SENSITIVITY ON INTERMEDIATE CHANNELS

Band	Channel Bandwidth (MHz)	Channel	Frequency (MHz)	FS EIS _(IC) (dBm)	BHHR EIS _(IC) (dBm)	WL/WR EIS _(IC) (dBm)
48	10	55910	3617			
48	10	55990	3625			
48	10	56070	3633			
48	10	56150	3641			
48	10	56240	3650			
48	10	56330	3659			
48	10	56420	3668			
48	10	56510	3677			
48	10	56600	3686			
48	10	56690	3695			
66	10	66486	2115			
66	10	66566	2123			
66	10	66636	2130			
66	10	66706	2137			
66	10	66786	2145			
66	10	66866	2153			
66	10	66936	2160			
66	10	67006	2167			
66	10	67086	2175			
71	10	68636	622			
71	10	68706	629			
71	10	68761	634.5			
71	10	68816	640			
71	10	68886	647			

O.10.2 Relative Measurement Testing Using Different Samples / Chambers

The contents of this section are no longer needed since [Section 1.5](#) has been updated to clarify the use of relative measurement testing using different samples/chambers.

O.10.3 Clarification on Resets Between Measurements During A-GNSS Sensitivity Measurement

The contents of this section are no longer needed since [Section 6.13](#) has been updated to clarify resets between measurements during A-GNSS sensitivity testing.

O.10.4 Conducted Performance Testing of 2 DL and 3 DL LTE CA

This section is no longer needed as [Section 5.12](#), and [Section 6.16](#) have been updated to remove conducted performance testing.

O.10.5 LTE CA Summary Tables

This section is no longer needed as Appendix B.1 has been updated to incorporate the new LTE CA summary tables.

O.10.6 Waiver for LTE A-GLONASS OTA Testing when using SIB8 or SIB16

[Section 6.13.5.4.3](#) requires LTE A-GLONASS OTA testing when SIB8 or SIB16 is broadcasted depending on the device support and manufacturer declaration. This requirement will be waived until there has been a commercial reference device identified for the CTIA Certification.

Laboratory Assessment and Validation Requirements Document for v3.7.x and test solutions have been validated and listed on the authorized test equipment list. All other LTE A-GLONASS OTA requirements in [Section 6.13.5.4.3](#) remain in effect if the device supports LTE A-GLONASS functionality. This waiver also does not modify any of the existing requirements for LTE A-GPS OTA testing when SIB8 or SIB16 is broadcasted. The requirements in [Section 6.13.5.4.1](#) and [Section 6.13.5.4.2](#) remain as is.

O.10.7 Modifications to LTE Category M1 Power Measurements

This section is no longer needed since Appendix D has been updated to add LTE Category M1 power measurements.

O.10.8 Sensitivity Factors for Numerical Evaluation of Phone Positioning Uncertainty for 3000 - 6000 MHz Range

For frequencies in the range of 3000 - 6000 MHz, the sensitivity factors used to calculate the phone positioning uncertainty shall be adjusted from those given in [Appendix G.10.5.2](#). The sensitivity factors $k_1 = 0.18$, $k_2 = 0.07$, $k_3 = 0.14$ and $k_4 = 0.44$ shall only be considered valid for the frequency range of 600 - 3000 MHz. For the frequency range of 3000 - 6000 MHz, $k_1 = 0.13$, $k_2 = 0.14$, $k_3 = 0.15$ and $k_4 = 0.33$ shall be used instead.

O.10.9 Dipole Symmetry Allowances for Ripple Testing

Replace the text in the footnote in section 3.2 as follows.

¹The asymmetry specification for purposes of this measurement may be stated more specifically as the pattern shall not deviate from a perfect circle by more than 0.1 dB (0.2 dB peak-to-peak) without applying the additional measurement uncertainty as described in [Section 3.3](#). Sleeve dipoles and center fed balanced loop antennas are recommended since the cable and feed point may be arranged in such a way that interactions with the measurement are minimized. The asymmetry specification holds only at the frequency at which the ripple test is performed (see [Table 3-3](#)). The gain and efficiency of this antenna is immaterial since the measurement seeks to determine deviations in the measured antenna pattern caused by reflections within the measurement chamber.

After the procedure on page 47 in [Section 3.5.1](#), replace the text in the last paragraph as follows:

The total ripple observed in this symmetry test should be less than ± 0.1 dB from the midpoint (0.2 dB peak-to-peak) in order for the associated probe antenna to be used for the remaining tests. In cases where it is not possible to use a dipole with the desired symmetry (e.g. where a smaller than resonant dipole is needed due to mechanical constraints of the positioning system) a dipole with a larger measured asymmetry value may be used provided the asymmetry error in excess of ± 0.1 dB is combined with the corresponding surface standard deviation (SSD) or maximum ripple measurement results by the root-sum-of-squares (RSS) method. For example, assume that the (+, -) position of the phi-axis ripple test requires the use of a dipole with an asymmetry of ± 0.3 dB and measures an SSD of ± 0.5 dB, then the reported result for that position would be $((0.3 - 0.1)^2 + 0.5^2)^{1/2} = \pm 0.54$ dB. The maximum dipole asymmetry allowed with this method shall be ± 0.5 dB. For combined-axes positioning systems where a dipole with dipole symmetry exceeding ± 0.1 dB is used, the symmetry test shall be performed at the (0,0,0) location of the theta-axis dipole ripple measurement, with as much of the phi-axis support structure removed as possible.

Appendix P Integrated Device Appendix (Normative)

P.1 Purpose

The purpose of this appendix is to define the CTIA Certification program test requirements for performing Radiated RF Power and Receiver Performance measurements on:

- Integrated devices with an integrated, non-removable antenna attached to the device according to [Appendix O.5](#)
- Integrated devices with a removable antenna physically attached to the device according to [Appendix O.5](#)

P.2 Scope

The scope of this appendix is limited to specific setup and measurement criteria to be used when an integrated device using an internal or directly attached antenna is submitted to a ATL for RF Performance testing. All other equipment, equipment set up and test procedures documented in the CTIA Certification OTA Test Plan will apply.

P.3 Equipment Under Test - Setup

The EUT shall be tested in a normal operating state, but shall be configured as follows (as it applies). The manufacturer shall provide instructions to the ATL for placing the EUT in this state.

- Transmitting radios:
 - WWAN - On
 - WLAN (Wireless Local Area Network) - Off
 - Bluetooth™ - Off
 - WiMAX™ - Off
 - UWB (Ultra Wideband) - Off
 - All other embedded transmitting radios that are not being tested - Off
- Power Settings
 - Device should be placed into normal operating mode (minus the radio configuration as explained above)
 - Power by battery, if possible, to reduce interference (standard manufacturer's battery)
 - Power by AC/DC power supply when needed using manufacturer's settings and current draw
(ensure to take care when using a power cord: avoid the antenna and power cord coming in close proximity of each other, if possible, and placing the power cord in ferrite tubing can help reduce RF interference).
 - Device manufacturer to provide ATL with specific guidance

- As required, a user-configurable WWAN antenna will be positioned in accordance with the manufacturer's recommended configuration (See [Appendix O](#) for further information)
- Attachment of Additional EUT Accessories (i.e., non-antenna accessories)
 - Accessory(ies), if needed, will be attached and positioned on or around the EUT according to the manufacturer's recommended configuration. This recommended configuration must be representative of normal use of the EUT and be maintained by the ATL during all testing of that EUT.
 - Reasonable effort shall be taken to maintain the quiet zone or at least minimize the impact on the quiet zone.
 - Photographs of sufficient detail of the set-up shall be included in the test report to enable the reproduction of the tests.

P.4 Required Testing

P.4.1 Free Space Testing

Integrated devices and integration components shall be tested in a Free Space configuration, unless specific phantom testing is defined such as body worn.

The integrated device or integration component may be held in the defined free space position by a custom designed holding fixture. The holding fixture shall be made of a material with a dielectric constant of less than 5.0, and loss tangent less than 0.05. The fixture shall not extend beyond the footprint of the integrated device by more than 20 mm, and shall be no more than 20 mm in thickness.

P.4.2 Body Worn Testing

Integration Components are commonly integrated into clothing and in cases where an Integration Component is intended to be used with clothing then no free space testing is required if body worn testing is performed. An Integration Component should be tested in a "Host Product" declared by the manufacturer as being one of the most common "Host Products".

OTA testing shall be performed with the applicable body phantoms as defined in this test plan. In addition, network operators, or other customers may request testing with non-standardized body phantoms when standardized body phantoms are not applicable or not defined. In such cases, standard fixturing and positioning shall be observed to the extent possible, and the data shall be included and marked as supplemental in the test report.

P.5 Physically Reconfigurable Devices

Certain devices support usage in more than one physical configuration, such as an integrated device placed on a wall or on a desk in normal operating mode (vertical and horizontal plane). Each configuration may produce different radiated performance due to possible changes in antenna orientation (e.g., horizontal and vertical polarization measurements could change). Consequently, such devices may require testing in more than one configuration. At a minimum, the device shall be tested in the manufacturer's recommended configuration(s).

P.6 Integrated Devices with Extendable/Retractable Antennas

Some retractable antennas used for integrated devices are functional only in the extended position. In such cases, the device shall only be tested with the antenna in the manufacturer's recommended configuration.

P.7 Considerations for Externally-powered Devices

In the case of all devices that utilize an external power cable as part of the intended final market application, the cable shall be considered part of EUT (equipment under test). The device manufacturer should provide guidance on the positioning of such cables so that they do not cause cross coupling or introduce unwanted noise within their device throughout the test process.

The ATL shall ensure the following:

- All external cables are secured in such a way that the cables remain in the same position throughout the rotation of the device.
- Any external power sources are free from noise and that the source does not affect the RF performance of the equipment under test

The ATL shall use the appropriate chamber type; some combined-axes systems are unsuitable in keeping cable movement to a minimum. The ATL shall test in the primary mechanical mode only.

Devices that are externally powered are categorized as follows:

- Internal power supply with external continuous power requirements
The EUT should be tested with the manufacturer-supplied cable and power supply assembly. The test chamber power source shall be stable, isolated, free from any influencing noise and placed to minimize degradation of the quiet zone.
The ATL shall maintain supporting evidence that the power source utilized throughout the testing meets the above criteria.
- External power requirements such as automotive devices
The manufacturer should supply a suitable automotive type cable together with the voltage and current requirements.
The power source shall be free from any noise or switching frequencies that may cause any form of self-interference that may have an impact of measurement accuracy.
The ATL shall maintain supporting evidence that the power source utilized throughout the testing meets the requirements of the above criteria.
- USB-powered Devices
The manufacturer shall supply a USB cable together with a charging source that is a market application of the product. Where the manufacturer does not supply a USB cable, the ATL shall utilize a suitable cable and charging/power source which shall be isolated and free from any noise that may influence the accuracy of the test results. Any charging/power source that is utilized shall be placed within the chamber to minimize degradation of the quiet zone.
The ATL shall maintain supporting evidence that the power source utilized throughout the testing meets the requirements of the above criteria.
- Battery-powered devices that would require an external power source to maintain a TRP/TIS test

When the device has insufficient power capacity to maintain the cellular link for at least 50% of the execution time of a single channel TRP or TIS test, the ATL should then advise the customer that the charging cable will be utilized throughout the test process. The cable shall be free from any noise that may influence the accuracy of the test results, with the use of ferrites/chokes highly recommended. The power source that is utilized within the chamber shall be placed such that degradation to the quiet zone is minimized. The ATL shall maintain supporting evidence that the power source utilized throughout the testing meets the requirements of the above criteria.

P.8 Multi-Protocol Devices

Embedded WWAN data modules commonly support multiple protocols or air interfaces (e.g., GPRS/EGPRS/UMTS) within the same frequency band. In cases where particular modes are not relevant to the intended use of the EUT, it is allowable to test only a subset of the supported protocols. The device manufacturer shall specify the intended use cases (e.g., test mode, data rate, channel set up).

Note that these guidelines shall not preclude using the alternative single-point and multi-point offset test procedures for TIS and TRP described in the CTIA Certification OTA Test Plan. For example, in the event that the manufacturer and operator agree that voice-mode results are not required for certification, the ATL may nevertheless opt to measure TIS and TRP in a voice mode to take advantage of the test time optimization provided by those alternative procedures. The manufacturer should be aware that certain protocols not required by the operator for certification may nonetheless be needed by the ATL and should be available on the device submitted for testing.

P.9 A-GNSS Testing for Integrated Devices

P.9.1 Testing Overview

The A-GNSS testing shall follow requirements per [Section 6.13](#). As discussed earlier in the Appendix, testing should be performed in free-space configuration only.

P.9.2 Criteria

This section deleted in Version 3.8. Starting with Version 3.8, A-GNSS criteria for integrated devices are included in [Section 6.13.6](#).

P.9.3 Reporting of Test Results

This section deleted in Version 3.8. Starting with Version 3.8, the reporting tables for integrated devices have been moved to the spreadsheet "OTA 3.9.x Appendix B Tables."

P.10 Chamber Placement

To minimize the physical volume occupied by the EUT during testing, the center of rotation shall be the three-dimensional geometric center of the EUT and not the antenna.

P.10.1 Positioning an Integrated Device Relative to the Chamber Coordinate System

The reference plane for the EUT is defined as the plane on which the base of the EUT sits. This plane will be normal to the phi axis of the chamber.

Before placing the EUT in the chamber, place the integrated device on a level surface and measure the height, width and depth (H , W , D) of the device to determine the center of each (mark with tape if need). The center of the height, width and depth of the device shall be located at the origin of the chamber coordinate system.

FIGURE P-1 INTERNAL ANTENNA

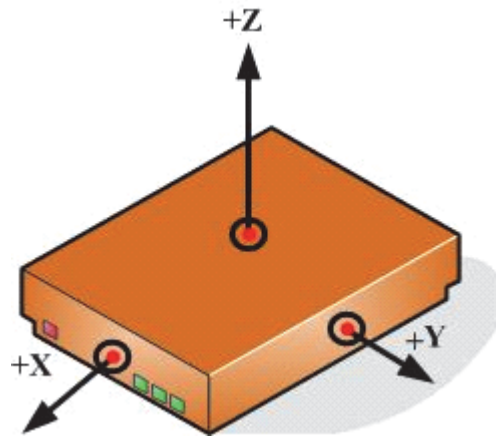
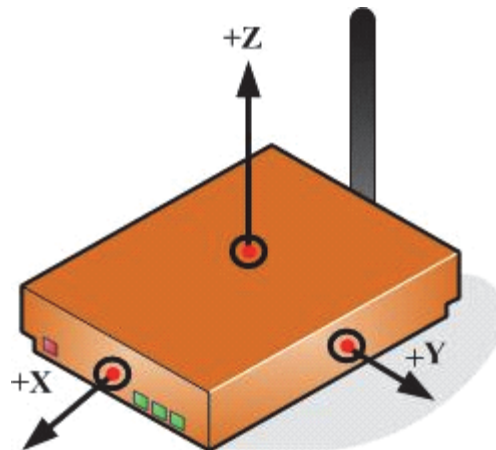

FIGURE P-2 DIRECT CONNECT EXTERNAL ANTENNA (IT DOES NOT MATTER WHERE THE ANTENNA IS LOCATED AS YOU WILL CENTER ON THE DEVICE)



P.10.2 Minimum Measurement Distance Considerations

Due to the large form factor of some integrated devices, the minimum measurement distance criteria, in particular, the $2D^2/\lambda$ limit specified in [Section 3.1](#) of the CTIA Certification OTA Test Plan cannot be satisfied on shorter ranges.

To cover the large form factor devices the ATL shall stay within the notebook-sized quiet zone size dimensions detailed in [Section 3.6](#).

However, an additional standard uncertainty value must be included in the total EUT measurement uncertainty calculation to account for the violation of the far field as identified in [Appendix G.19.1](#).

P.10.3 Positioning an Integrated Device with a Removable Antenna Connected Directly to the Device via an RF Transmission Line (Such as a Coaxial Cable) Less Than 20 cm in Length

Due to the numerous possible configurations of this device type, the ATL will work with the vendor to determine the best possible configuration(s) (multiple if needed) of the device in the chamber to be tested. The ATL will need to take care in documenting this in the report. This will include but will not be limited to the following:

- Vendor shall work with the ATL, and or define the configuration for the ATL to perform the test plan in a consistent manner.
- Taking picture of the set-up so it can be clearly understood how the device was configured in the chamber.
 - Identify the center point of the chamber and clearly mark a cross-hair using the right hand rule on each image taken in the chamber.
 - Identifying, documenting and maintaining the distances between cables (e.g., power cord(s), antennas, etc.) throughout the measurements which can have an effect on the radiated performance of the testing.
- Each piece of equipment (e.g., Antenna(s), power cords, etc.) used during testing shall be marked and documented, at minimum, in the ATL report to reduce variables upon retest.
 - This equipment and only this equipment shall be used if any additional testing is needed.

P.11 Additional Measurement Uncertainty

P.11.1 Ripple Uncertainty

The ripple uncertainty associated with larger devices shall be determined as described in [Section 3.7](#) and [Appendix G.8](#) of the CTIA Certification OTA Test Plan, using data collected from the additional ripple test procedure for notebook-sized volumes defined in [Section 3.6](#).

P.11.2 Uncertainty Due to Minimum Measurement Distance

Please refer to [Appendix P.10.2](#) for guidance

P.11.3 Additional Coarse Sampling Grid Uncertainty

The TIS measurement uncertainty associated with using a 30° pattern grid spacing is discussed in [Appendix G.12](#) of the CTIA Certification OTA Test Plan. It is conceivable that this source of uncertainty is worse for devices larger than the hand and head phantom configuration for which this effect was originally assessed.

P.12 Testing of Cellular Desense due to Simultaneous Operation of 802.11 Radios for Integrated Devices

P.12.1 Scope

This sub-section describes the test requirements for determining desensitization of the cellular radio in integrated IoT devices due to simultaneous operation of an integrated 802.11 radio. For devices where the 802.11 radio will never operate during communication over the cellular radio interface, this test is not required. This test does not measure the impact of cellular communication on the 802.11 wireless interface.

P.12.2 Testing Overview

The cellular desensitization test consists of repeating the relative sensitivity on intermediate channels test in the presence of the 802.11 uplink interferer for each cellular radio mode supported by the EUT. The 802.11 uplink interferer shall be produced by transmitting unicast UDP packets containing 1000 bytes to the EUT on a 1 - ms interval so that the ACKs of each packet serve as the interfering signal. The interferer shall be generated using a 20 MHz wide channel per the following criteria. For devices that operate in the 2.4 GHz ISM band, the interferer shall be generated on channel 6 using the lowest supported mode: 802.11b @ 11 Mbps, 802.11g @ 6 Mbps, or 802.11n/ac @ 6.5 Mbps. For devices that operate in the 5 GHz band, the interferer shall be generated at the lowest supported of the following channels: 44, 60, 120, 157, or 165; and using the lowest supported mode: 802.11a @ 6 Mbps or 802.11n/ac @ 6.5 Mbps.

P.12.3 Testing Procedure

The following test procedure demonstrates one possible process flow, but an alternate process order may be used, provided all required tests are performed.

1. For each independent 802.11 transmit antenna configuration, enable that configuration as the interferer. When a device contains multiple 802.11 TX antennas, the guidelines in [Section 5.14](#) shall be used for configuring the 802.11 TX antennas.
2. Establish an 802.11 connection with the communication tester and transmit UDP packets to the EUT at the required rate as defined in [Appendix P.12.2](#) so that the EUT is generating ACK packets at the required periodic rate.
3. For each cellular radio mode and applicable test configuration of the EUT, repeat the relative sensitivity test on all intermediate channels, including the low/mid/high reference channels, in the presence of the 802.11 uplink interference.
4. Repeat the process until all applicable cellular radio modes, test configurations, and 802.11 transmit configurations have been tested.

P.12.4 Criteria

Relative sensitivity on intermediate channels test results shall be provided in a file format equivalent to that specified in [Appendix B.1](#) (or [Appendix O.10.1](#) as applicable). Separate reporting tables shall be created for each 802.11 interferer and labeled with the 802.11 interferer.

Appendix Q Wrist-worn Device Appendix (Normative)

Q.1 Purpose

The purpose of this appendix is to define the CTIA Certification program test requirements for performing Radiated RF Power and Receiver Performance measurements on devices that are worn on the wrist.

Q.2 Scope

The measurement uncertainty associated with wrist-worn device positioning on the forearm phantom is expected to be less than the measurement uncertainty associated with handset positioning in the hand phantom. This measurement uncertainty will be studied further in the future and better defined in the future.

Q.3 Equipment Under Test -Setup

The EUT shall be tested in a normal operating state, but shall be configured as follows (as applicable). The manufacturer shall provide instructions to the ATL for placing the EUT in this state.

- Transmitting radios:
 - WWAN - On
 - WLAN (Wireless Local Area Network) - Off
 - Bluetooth™ - Off
 - WiMAX™ - Off
 - UWB (Ultra Wideband) - Off
 - All other embedded transmitting radios that are not being tested - Off
- Power Settings
 - Device should be placed into normal operating mode (minus the radio configuration as explained above)
 - Power by battery, if possible, to reduce interference (standard manufacturer's battery)

The manufacturer shall declare the wristband to be used during the testing. The wristband to be used shall be the wristband packaged with the end product. If wristbands are provided separately, the wristband selection shall be based on the expected worst-case wristband.

The manufacturer shall declare the housing material to be used during the test based on the expected worst-case material.

Q.4 Wrist-worn Testing

Wrist-worn devices are used primarily in the wrist-worn position. Wrist-worn devices shall only be tested in the wrist-worn configuration using the Forearm Phantom defined in [Appendix Q.5](#) and not in the free space condition.

The manufacturer shall declare the single arm orientation (WL or WR) for test based on the expected worst-case orientation and based on input from target operators.

It is not necessary to measure nor report the following quantities for wrist-worn devices: NHPRP, NHPIS, UHIS, nor PIGS, primarily because the orientation of the wrist-worn device varies so much in normal usage that these partial quantities don't have much bearing on the user experience. Note that while UHIS measurements are not required, measurements at the peak in the upper hemisphere pattern will still be used instead of the peak in the entire pattern in order to avoid complicating the test implementation.

Relative sensitivity on intermediate channel testing shall be performed on the single arm orientation (WL or WR) declared by the manufacturer.

Note that the current relative sensitivity on intermediate channels test procedure cannot be directly applied to wrist-worn devices until wrist-worn OTA limits are adopted. For LTE, [Appendix O.10.1](#) shall apply to wrist-worn devices.

Q.4.1 Wrist-Worn Device A-GNSS Testing Requirements

The following modifications to the A-GNSS testing requirements are applicable to wrist-worn devices.

Q.4.1.1 A-GNSS Sensitivity Criteria

The success rate defined in [Table 6-16](#) shall be modified to "24 successful fixes with the necessary accuracy out of 25 attempts".

Note: *While no explicit measurement uncertainty is assigned to the confidence associated with the pass/fail criteria of any sensitivity measurement, the measurement uncertainty associated with the pass/fail criteria of 24 successful fixes out of 25 fix attempts is greater than the measurement uncertainty associated with the standard A-GNSS pass/fail criteria of 95 successful fixes out of 100 fix attempts.*

Q.4.1.2 A-GNSS Signal Level for Pattern Measurement

In cases where it may be necessary to increase the A-GNSS signal level during the Radiated 3D C/N₀ Pattern Measurement in [Section 6.13.2](#) the A-GNSS signal level may be increased by up to 5 dB. Care should be taken to avoid compression of the receiver as mentioned in [Section 6.15.4.2](#).

Q.4.1.3 A-GNSS Linearization Dynamic Range Reduction

C/N₀ measurements shall be made at a maximum of 1 dB steps from the peak C/N₀ measurement to at least 5 dB below the peak C/N₀ measurement. Any data points in the pattern where no measurement was obtained shall use a replacement value that is at least 20 dB below the lowest C/N₀ measurement.

Q.5 Forearm Phantom Definitions and Requirements

Contact cpwg@ctiacertification.org to obtain forearm phantom-related CAD files.

Companies interested in manufacturing forearm phantoms should contact CTIA Certification at programs@ctiacertification.org to obtain additional dielectric parameter information on the existing forearm phantoms in order to best align the OTA performance impact of new forearm phantoms with the OTA performance impact of the existing forearm phantoms.

Q.5.1 Forearm Phantom Dielectric Parameter Requirements

The relative permittivity of forearm phantoms shall be within $\pm 15\%$ of the values listed in [Table C-3](#). The conductivity of forearm phantoms shall be within $\pm 25\%$ of the values listed in [Table C-3](#). The dielectric parameters shall be determined in a manner similar to the method for evaluating hand phantoms in [Appendix G.10.3](#) using the methods in [Appendix H](#) across the frequency bands for which the forearm phantom is to be used (see [Appendix Q.9](#)). The RF dielectric parameters may be certified by the forearm phantom manufacturer or determined by the test lab. The manufacturer shall provide a certificate indicating compliance over the applicable bands, including the measurement methodology and results, when they are certifying compliance with the RF dielectric parameters.

Q.5.2 Forearm Phantom Identification

The forearm phantoms shall be traceable by their model and serial number. Forearm phantom manufacturers shall provide a reference material block made of the same material as its associated forearm phantom, which is suitable for measuring its dielectric properties (see [Appendix G.10.3](#)). Each forearm phantom shall be traceable to its associated reference material block. The identification marking of the forearm phantom shall be on the forearm, or on any mounting boss attached to the forearm, specifically in an area where there is no chance of interaction with the OTA measurement.

Q.5.3 Forearm Phantom Fixturing Requirements

The primary goal of the fixture is to allow the stable mounting of the forearm phantom and EUT in the chamber, while also being transparent and non-reflective to RF. The material for the forearm phantom fixturing shall have a dielectric constant of less than 5.0 and a loss tangent of less than 0.05. The fixturing shall be kept below the base of the forearm phantom.

No additional measurement uncertainty from the forearm phantom fixture is needed as long as the above requirements are met.

Q.5.4 Forearm Phantom

The Forearm phantom consists of cylindrical and conical sections, as shown in [Figure Q-1](#). The perimeter of the conical section is 162.7 mm at the target test location (corresponding to the 50th percentile wrist circumference), indicated by a ring marking engraved around the phantom. Elsewhere, the perimeter of the conical section varies linearly from 144.0 mm to 224.5 mm over its longitudinal length of 215 mm.

FIGURE Q-1 FOREARM PHANTOM WITH TARGET TEST POSITION

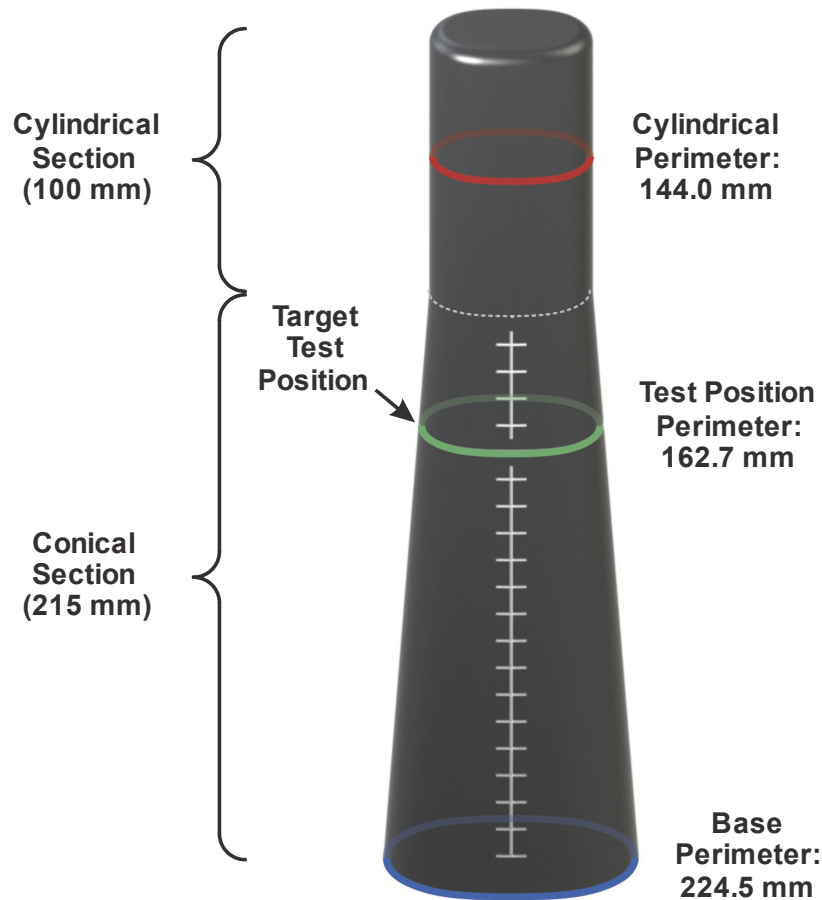

Q.5.5 Forearm Phantom - Reference Information

The Forearm phantom used in this test plan was selected for the following reasons:

- The anatomical hand was not included a) to enable easy positioning of wrist-worn devices onto the forearm phantom, in particular to allow fixed-circumference, rigid “bangle”-type devices to be snugly fitted at locations deviating from the target engraved marking as necessary, with minimum impact (i.e., without bringing them nearer to/farther from a hand phantom discontinuity) and b) to enable use of a single phantom for both left and right forearm testing.
- The simplified shape for the forearm was selected a) to eliminate the ulna bump in the forearm to enable repeatable positioning of wrist-worn devices on the forearm phantom and b) to enable the use of a single phantom for both left and right forearm testing.

Measurements taken from the following reference, Thomas M. Greiner; *Hand Anthropometry of US Army Personnel, Army Natick Research Development and Engineering Center*, 1991, were used as a guide in defining the forearm phantom:

TABLE Q-1 SELECTION OF STATISTICS FROM US ARMY DATA ON ENLISTED PERSONNEL

Body part	Mean / 50% percentile male (cm)	Mean / 50% percentile female (cm)	Model Dimension (cm)
Wrist Circumference	17.43 / 17.40	15.14 / 15.11	14.4 (smallest), 16.27 (test position)
Forearm Circumference, flexed	30.39 / 30.28	25.41 / 25.34	22.45 (base dimension)
Radiale-Stylian length	26.93 / 26.83	24.36 / 24.32	21.5 (conical section)

The wrist circumference was chosen to be the average of the mean and 50th percentile of males and females from the US Army data. The slope of the conical section taper away from the target test position (forearm circumference, flexed) was reduced in order to ensure reasonable flatness at the test location. The length of conical section (radiale-stylian length) was selected to be long enough to properly model the impact of the forearm on wrist-worn devices and to locate the wrist-worn DUT in the center of the chamber quiet zone.

Q.6 Positioning Guidelines for wrist-worn Devices

Q.6.1 Positioning of wrist-worn EUT Relative to the Chamber Coordinate System

The Forearm Phantom shall be mounted in the chamber coordinate system as shown in [Figure Q-2](#).

FIGURE Q-2 Cartesian Coordinate System For Forearm Phantom

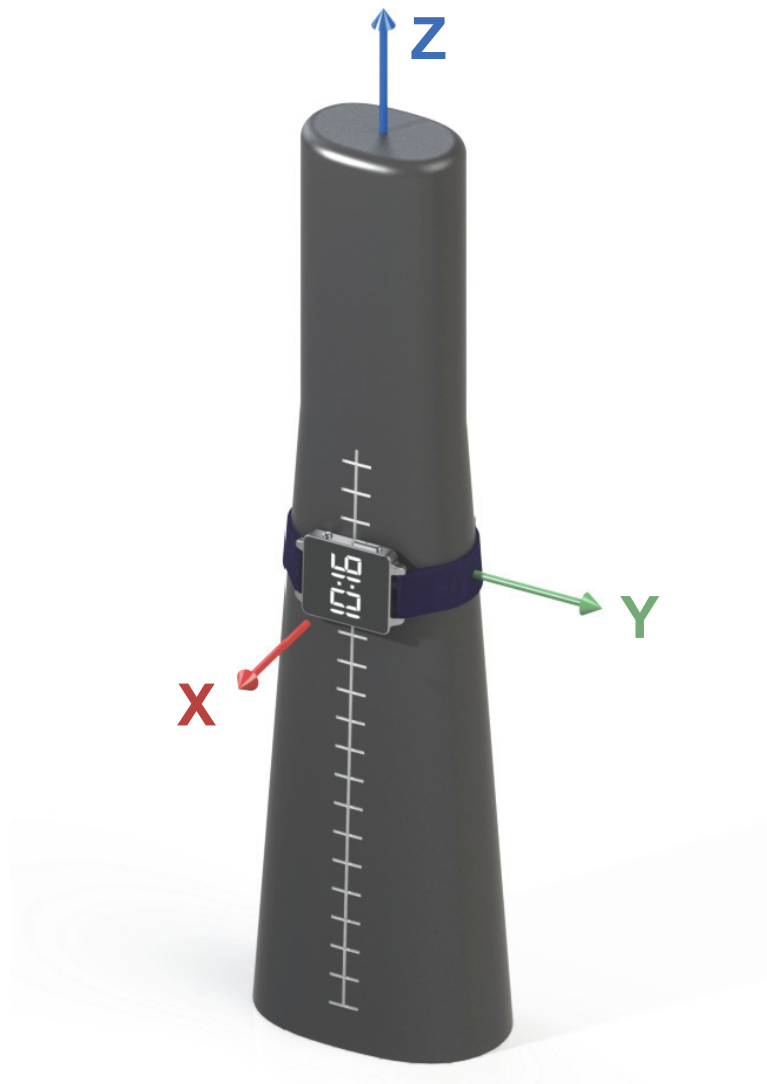

Q.6.2 Mounting a Wrist-Worn EUT on the Forearm Phantom

Define Plane *J* and Plane *K* as shown in [Figure Q-3](#). Plane *J* cuts through the surface of the forearm phantom and passes through the target test position and is perpendicular to the Y-axis. Plane *J* is the X-Z plane. Plane *K* cuts through the forearm phantom at the target test position and is perpendicular to the Z-axis. Plane *K* is the X-Y plane.

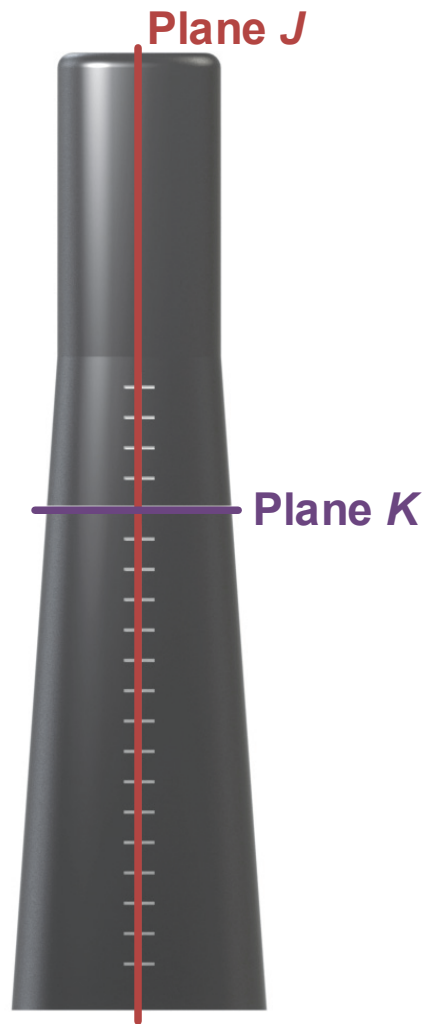
FIGURE Q-3 Definition of Plane *J* and Plane *K* on the Forearm Phantom

Define a local coordinate system for a wrist-worn device as shown in [Figure Q-4](#).

FIGURE Q-4 Local Coordinate System for a wrist-worn Device

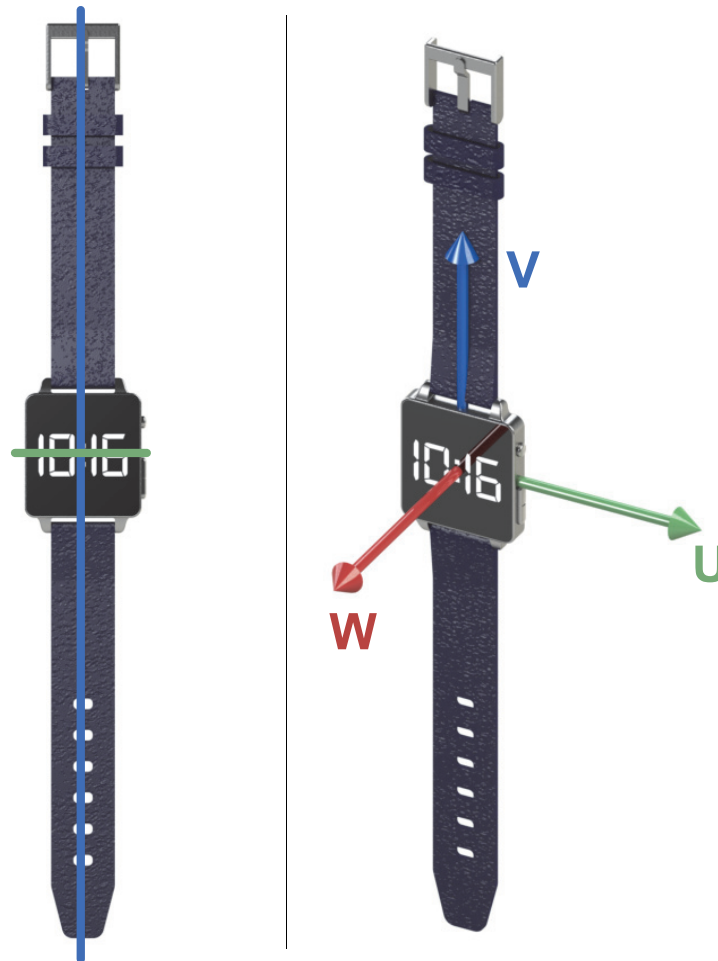

First define a virtual Plane A that cuts through the center of wrist band on the U-axis and is perpendicular to the U-axis as shown in Figure Q-5. Thin, narrow, non-conductive tape may be used to mark where Plane A cuts through the device without introducing any additional measurement uncertainty. If the lines are not marked, it is recommended to measure the width of the device with a ruler and mathematically determine the space needed between the side edges of the device and the nearest engraved graduated markings on the forearm.

FIGURE Q-5 Definition of Plane A and Plane B on a wrist-worn Device



In general, if the device has a wrist band which can be easily flattened, then define a virtual Plane *B* that cuts through the center of the display on the V-axis and is perpendicular to the V-axis, as shown in [Figure Q-5](#). Thin, narrow, non-conductive tape may be used to mark where Plane *B* cuts through the device without introducing any additional measurement uncertainty. Plane *B* shall be fully aligned with Plane *J* when the device is mounted on the forearm phantom as shown in [Figure Q-6](#).

FIGURE Q-6 ALIGNMENT OF PLANE A WITH PLANE K AND PLANE B WITH PLANE J WHEN A WRIST-WORN DEVICE, WHICH CAN BE LAID OUT FLAT, IS MOUNTED ON THE FOREARM PHANTOM

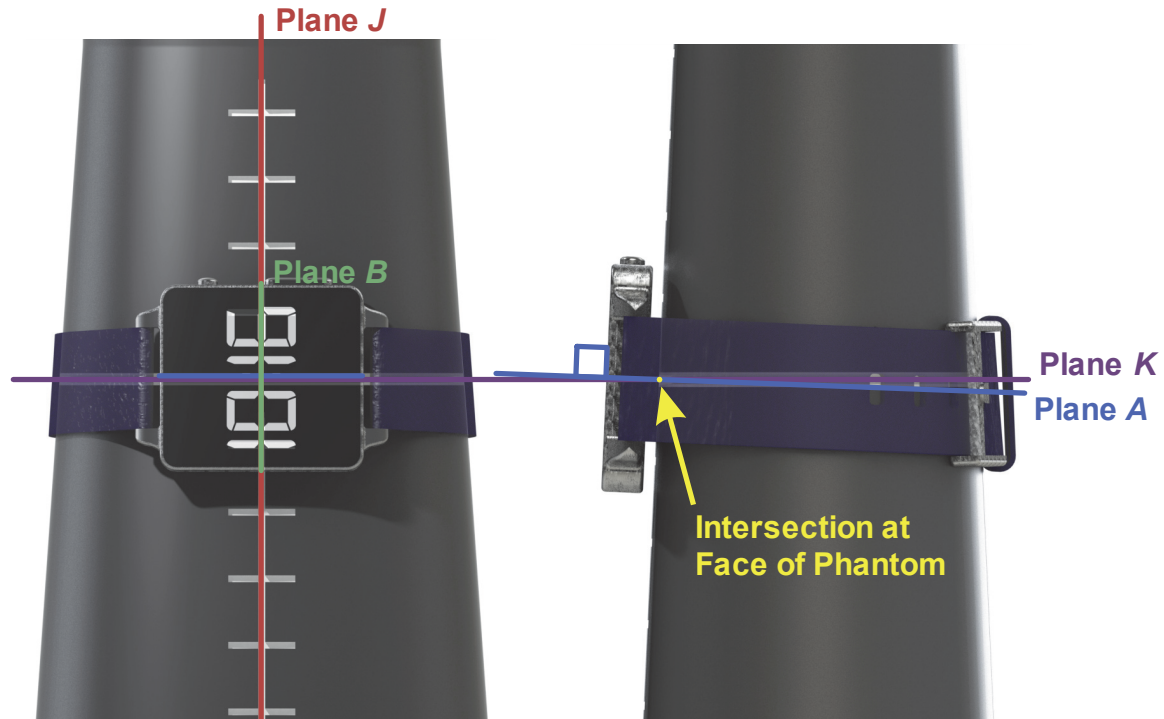

In Figure Q-6, Plane A and Plane K shall intersect to form a line that is tangent to the surface of the forearm phantom at the target test position. Note that Plane A may only intersect Plane K to form a line that is tangent to the surface of the forearm phantom at the target test position, instead of being fully aligned, as seen in Figure Q-6 because the band may need to be adjusted up or down in the Z direction in order to position the main module parallel to the forearm phantom surface.

If the device has a wrist band with a pre-formed shape, then define a virtual Plane B which is perpendicular to the V-axis and is located on the device such that Plane B shall fully align with the Plane J on the forearm phantom when the device is snugly fitted to the forearm phantom as shown in Figure Q-7.

FIGURE Q-7 ALIGNMENT OF PLANE A WITH PLANE K AND PLANE B WITH PLANE J WHEN A WRIST-WORN DEVICE WITH A PRE-FORMED WRIST BAND IS MOUNTED ON THE FOREARM PHANTOM

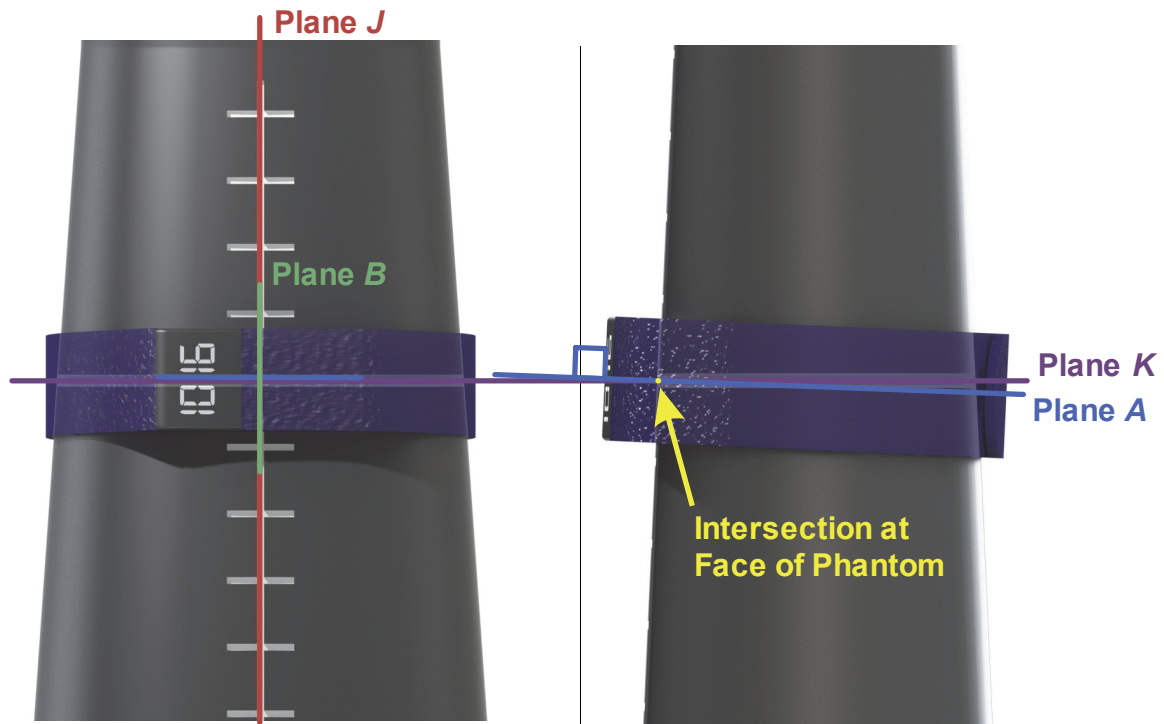

In both [Figure Q-6](#) and [Figure Q-7](#), the device shall be positioned such that Plane A is perpendicular to Plane J of the forearm phantom.

If the section of the pre-formed shape of the wrist band is somewhat symmetric, then Plane B shall be the centerline of the wrist band shape as shown in [Figure Q-8](#).

FIGURE Q-8 LOCATION OF PLANE *B* ON A WRIST-WORN DEVICE WITH A SYMMETRIC PRE-FORMED SHAPE

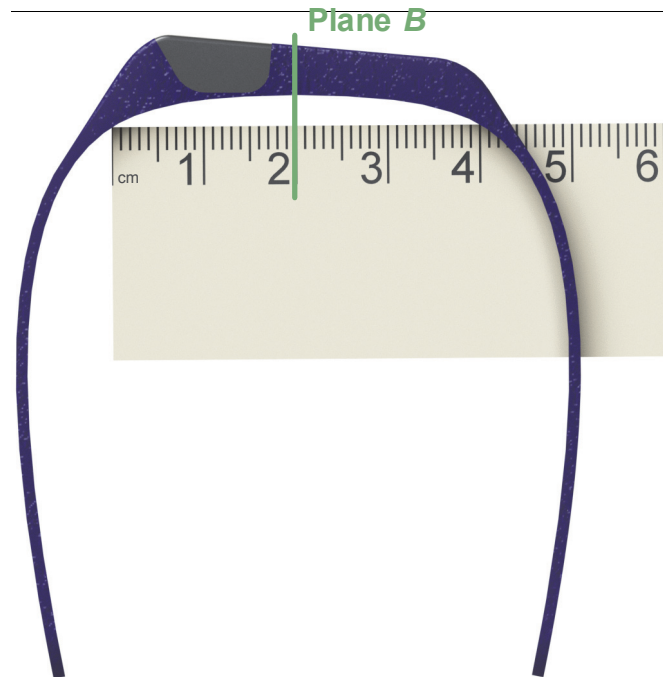

In general bands with multiple buckle stops have sufficient flexibility to mount the device snugly at the target test position. It may be useful to follow these steps when mounting a wrist-worn device with a flexible band onto the forearm phantom: (a) place the device at the target location with the band open, (b) buckle the wrist band as tightly as possible, (c) slide the device off the forearm phantom with the buckle closed, (d) tighten the buckle by one stop, (e) slide the device back onto the forearm and into the target position.

For wrist-worn devices which are unable to snugly mount at the target test position, the EUT shall be tested with the band set so that the EUT is located as near as possible to the target test location, and snugly mounted. Test reports shall include a photograph of wrist-worn devices, which need to be mounted away from the target test position, mounted on the forearm phantom clearly showing the engraved markings on either side of the engraved target test position ring.

In all cases, EUTs shall be mounted with sufficiently snug band tightness so as to prevent the EUT from slipping off under the force of gravity when the phantom is inverted.

When there is flexibility in the positioning, the main module shall be kept parallel to the surface of the forearm phantom as shown in [Figure Q-9](#).

FIGURE Q-9 EXAMPLES OF CORRECTLY MOUNTING THE DEVICE ON THE FOREARM PHANTOM BY KEEPING THE MAIN MODULE PARALLEL TO THE SURFACE OF THE FOREARM PHANTOM



In [Figure Q-10](#), the main module is tilted such that it is raised on the forearm phantom on the side closest to the hand.

FIGURE Q-10 EXAMPLE OF INCORRECTLY MOUNTING THE DEVICE ON THE FOREARM PHANTOM BY NOT KEEPING THE MAIN MODULE PARALLEL TO THE SURFACE OF THE FOREARM PHANTOM



When the longitudinal test position for a given EUT is identified, the EUT will be tested at this longitudinal position for one of two different orientations, representing being worn on the right or left wrist (with the band and display oriented in opposite directions), as shown in [Figure Q-11](#).

FIGURE Q-11 TWO ORIENTATIONS OF EUT ON FOREARM PHANTOM REPRESENTING THE LEFT AND RIGHT WRIST



Q.7 OTA Limits for wrist-worn Devices

This section deleted in Version 3.8. Starting with Version 3.8, criteria for wrist-worn devices are included in [Section 5](#) and [Section 6](#).

Q.8 OTA Reporting for wrist-worn Devices

This section deleted in Version 3.8. Starting with Version 3.8, the reporting tables for wrist-worn devices have been moved to the spreadsheet “OTA 3.9.x Appendix B Tables.”

Q.9 Additional Measurement Uncertainty

Additional uncertainty arises from:

- The tolerance of the forearm shape and dielectric properties
- Positioning the wrist-worn device on the forearm phantom with respect to the definitions provided in [Appendix Q.6.2](#).

The combined uncertainty of forearm, and EUT positioning on the forearm phantom shall be determined as:

TABLE Q-2 STANDARD UNCERTAINTIES FOR THE FOREARM, AND EUT POSITIONING ON THE FOREARM

Description of uncertainty contributions	Standard Uncertainty, dB
Forearm Phantom Uncertainty	See Appendix G.24.1
wrist-worn Device Positioning Uncertainty	See Appendix G.24.2

Appendix R Stand-Alone GNSS Test Methodology and Test Procedure (Informative)

R.1 Purpose

The purpose of this appendix is to define the test methodology and test procedure to measure stand-alone GNSS performance. Two methods are defined enabling different levels of testing for different classes of devices. The first method measures stand-alone GNSS acquisition sensitivity with location accuracy requirements similar to A-GNSS in [Section 6.13](#), and will be called the stand-alone GNSS acquisition sensitivity method. The second method measures stand-alone GNSS tracking sensitivity without any accuracy requirements, and will be called stand-alone GNSS tracking sensitivity method.

Note that the sensitivity criteria for both methods have offsets from each other and also to the A-GNSS sensitivity criteria.

R.2 Scope

The scope of this appendix will define the communication protocol and mechanism to enable testing standalone GNSS performance with acquisition sensitivity or with tracking sensitivity.

R.3 Communication Protocol

In A-GNSS, the communication between the EUT and the system to collect measurement data is via the signaling protocol defined in each of the corresponding cellular technologies, e.g. RRLP in GSM, RRC in WCDMA, and LPP and SUPL in LTE. For standalone GNSS EUT's, those signaling protocols are not applicable.

R.3.1 Stand-Alone GNSS Acquisition Sensitivity Method

To simplify the design and implementation effort to support different types of EUTs, e.g. wearables, IoT, etc., with various bearer interfaces (e.g., BT, 802.11x, LTE, WCDMA, GSM, CDMA, etc.), the communication protocol is defined to be running on the TCP/IP transport layer. It is generic and can support multiple operating systems of different types of EUTs and communication interfaces. Also, it can support new communication interfaces as long as they support TCP/IP.

The protocol is request/response based. According to the test procedure, the system sends a request to the EUT and the EUT acts on the command and provides a response to the system. The format of the message is defined as follows:

Request/Response Messages:

```
<Message ID> <PARAM1 ID>:<PARAM1 VALUE>;
    <PARAM2 ID>:<PARAM2 VALUE>;
    <PARAMN ID>:<PARAMN VALUE><CR><LF>
```

There are 6 messages needed to enable standalone GNSS with acquisition sensitivity testing. They are REQ_RESET_GNSS, RESP_RESET_GNSS, REQ_CN_MEASUREMENT, RESP_CN_MEASUREMENT, REQ_LOCATION and RESP_LOCATION.

The detailed definition and description of each message is in [Table R-1](#).

TABLE R-1 MESSAGE DEFINITION AND DESCRIPTION FOR STAND-ALONE GNSS ACQUISITION SENSITIVITY METHOD

Message ID	Description	Direction	Parameters & Values
REQ_RESET_GNSS	Request UE to clear all GNSS data, all historical data and results	System to EUT	TYPE:<COLD/WARM/HOT> Example REQ_RESET_GNSS TYPE:COLD
RESP_RESET_GNSS	Response whether the reset GNSS command succeeded or not	Device to EUT	RESULT:<OK/FAIL> Example RESP_RESET_GNSS RESULT:FAIL RESP_RESET_GNSS RESULT:OK;
REQ_CN_MEASUREMENT	Request UE to measure C/N0 for GNSS	System to EUT	GNSS:<GPS/GPS,GLONASS>; ACCURACY:<H/M/L>; ---- Default value is "H" and the other values ("M" and "L") are for future development. MAX_RESP_TIME:<#> ---- unit is second(s) Example REQ_CN_MEASUREMENT GNSS:GPS;ACCURACY:H;MAX_RESP_TIME:120

TABLE R-1 MESSAGE DEFINITION AND DESCRIPTION FOR STAND-ALONE GNSS ACQUISITION SENSITIVITY METHOD

Message ID	Description	Direction	Parameters & Values
RESP_CN_MEASUREMENT	Response to report C/N ₀ measurement	EUT to System	RESULT:<OK/FAIL>; TOTAL:<#>; GNSS:<GPS/GLONASS/-->; ----- A "--" is used when the device cannot determine the satellite constellation. SAT_ID:<#>; ----- A "--" is used when the device cannot identify the satellite. CN:<#>; ----- unit is dB, ",", not used for last satellite Examples RESP_CN_MEASUREMENT RESULT:FAIL; RESP_CN_MEASUREMENT RESULT:OK;TOTAL:3;GNSS:--;SAT_ID:--;CN:40;GNSS:--;SAT_ID:--;CN:38;GNSS:--;SAT_ID:--;CN:35 RESP_CN_MEASUREMENT RESULT:OK;TOTAL:3;GNSS:GPS;SAT_ID:1;CN:40;GNSS:GPS;SAT_ID:3;CN:38;GNSS:GLONASS;SAT_ID:20;CN:35
REQ_LOCATION	Request UE to report current location	System to EUT	GNSS:<GPS/GPS,GLONASS>; ACCURACY:<H/M/L>; MAX_RESP_TIME:<#> ----- unit is second(s) Example REQ_LOCATION GNSS:GPS;ACCURACY:H;MAX_RESP_TIME:120
RESP_LOCATION	Response to report UE location	EUT to System	RESULT:<OK/FAIL>; LAT:<#>; LONG:<#>; ALT:<#> Examples RESP_LOCATION RESULT:FAIL; RESP_LOCATION RESULT:OK;LAT:35.7500588894;LONG:139.6753692627;ALT:300.00

R.3.2 Stand-Alone GNSS Tracking Sensitivity Method

To simplify the design and implementation effort to support simpler EUTs, e.g., wearables, IoT, etc., with Bluetooth support, the communication protocol is defined to be the serial port interface.

Only one message needs to be supported to enable stand-alone GNSS with tracking sensitivity testing. A device dependent command is sent from the test system to the EUT over the Bluetooth serial port interface to start sending the GNSS receiver data in National Marine Electronics Association (NMEA) 0183¹ format from the EUT to the test system over the Bluetooth serial port interface. The NMEA 0183 standard defines the format of the data sent by the GNSS receiver to the Bluetooth engine on the same EUT. To reduce the amount of data being transferred, the EUT software may be configured to ignore all satellites other than those being measured.

R.4 Procedure

In general, the test procedure is similar to A-GNSS defined in [Section 6.13.1](#). The test will measure the Total Isotropic Sensitivity (TIS), the Upper Hemisphere Isotropic Sensitivity (UHIS) (theta = 0 to 90 degrees) and the Partial Isotropic GNSS Sensitivity (PIGS) (theta = 0 to 120 degrees) of the GNSS receiver. The test consists of:

- Radiated 3D C/N₀ pattern measurement
- Radiated GNSS sensitivity measurement

TIS, UHIS, and PIGS shall be fully measured as described in the following [Appendix R.5](#) and [Appendix R.6](#) and calculated pursuant to Appendices [B.3.3](#), [B.3.5](#) and [B.3.6](#). In all cases, the linearized C/N₀ values shall be used in the calculations. The EUT shall be tested in each functional configuration (antenna extended and retracted, etc.) and test position (hand, head, wrist) as recommended by the manufacturer. For test positioning requirements refer to appropriate sections of the test plan (e.g., [Appendix C](#) for devices used with head and hands, [Appendix L](#) for Notebooks and Tablets, [Appendix P](#) for Integrated Devices and [Appendix Q](#) for body wearable devices).

R.5 Radiated 3D C/N₀ Pattern Measurement

The pattern data shall be determined by averaging Carrier-to-Noise (C/N₀) measurements of all visible GNSS satellites for each measurement at each point on the sphere. The GNSS satellite simulator shall provide the number of satellites specified herein and each satellite vehicle shall be at the same power. Orthogonal linear polarizations will be measured. For one measurement, the reported satellite C/N₀ values shall be averaged. If it is necessary to obtain more measurements to reduce measurement uncertainty, repeat the measurements at the same position and polarization and independently average the reported satellite C/N₀ values for each measurement report. After a sufficient number of measurements have been made, average the average results that were obtained for each measurement report. Sufficient averaging shall be used to ensure that the measurement uncertainty is less than the value included in the measurement uncertainty budget. The C/N₀ pattern data shall be linearized per the linearization method specified in [Section 6.15.4.2](#).

The radiated 3D C/N₀ pattern measurement shall be performed for GPS L1. The GPS L1 satellite simulator shall implement GNSS Scenario #1 as defined in 3GPP TS 37.571-5 Section 6.2.1.2.1 for satellites simulated for 3GPP TS 37.571-1 subclause 7, sub-test 1. The scenario shall be reset before the initial satellites become no longer visible. The scenario shall be executed as required in Section 7.2 Sub-Test Number 1 of 3GPP TS 37.571-1 except that random errors shall not be applied to the UE locations and the alternating locations requirement shall not be implemented. Unless otherwise specified, the latest versions of the referenced 3GPP documents shall be used.

1. National Marine Electronics Association 0183 standard, Version 4.10 November 2008

The reference signal power level shall be -130 dBm for all GPS L1 and GLONASS satellites.

Although outside the recommendations outlined in this test procedure, it is possible to improve measurement time and reduce the number of non-achievable measurement points (no satellites reported) for EUTs with low antenna gain, by increasing the reference signal power level as long as the highest reported C/N₀ by the EUT is confirmed to be in the linear region of the receiver during the linearization step. Most GNSS receivers are linear up to 48 dB C/N₀. Note that the same reference signal power level must be used for the entire radiated 3D C/N₀ pattern measurement and when correlating the single point C/N₀ to the single point sensitivity measurement.

For GLONASS, the radiated 3D C/N₀ pattern measurement does not have to be performed. Further evaluation of stand-alone GLONASS performance will utilize the stand-alone GPS L1 radiated 3D C/N₀ pattern measurement.

R.5.1 Stand-alone GNSS Acquisition Sensitivity Method

In this method, each measurement is initiated with a measurement request message, and reported with a measurement report message.

R.5.2 Stand-alone GNSS Tracking Sensitivity Method

In this method, measurements are continually reported in NMEA format over the Bluetooth serial port interface. In order to ensure that the reported C/N₀ values are stable and accurate, wait 5 seconds after changing the angle or polarization, and then monitor the C/N₀ values. Average the satellites in each measurement report. Continue until 5 consecutive average measurement report results with a maximum deviation of less than 1 dB are received. C/N₀ results may be considered outliers and removed from the average when the results deviate (higher or lower) by more than 3 dB from the median C/N₀ of the reported satellites. Although outside the recommendations outlined in this test procedure it is possible to improve measurement time by reducing the deviation to 1.5 dB when identifying outliers.

Note that the same procedure used to collect the C/N₀ data for the 3D pattern will be used during the linearization process.

R.6 Radiated GNSS Sensitivity Measurement

The radiated GNSS sensitivity search shall be performed at the position/polarization where the peak C/N₀ value was obtained in the upper hemisphere. The EUT's GNSS receiver sensitivity will be the minimum GNSS signal level that results in a passing result for the applicable GNSS Sensitivity test specified herein. The maximum GNSS sensitivity search step size shall be no more than 0.5 dB when the satellite vehicle power level is near the GNSS sensitivity level.

The conducted GNSS sensitivity of the EUT shall also be measured at the antenna connector, if available. It is preferable that the EUT be the same as utilized for the TIS measurements. However, if the EUT does not readily support an antenna port for conducted measurements, a separate modified EUT may be provided for all conducted measurements. If no connector is available, the conducted sensitivity measurement is not required. Ideally, the sensitivity measurement will be performed with the same instrumentation in an equivalent configuration in order to minimize the measurement uncertainty involved. A different sensitivity measurement device may be used as long as any differences in absolute measurement accuracy are accounted for, either in corrections to the recorded sensitivity level or

increased reported measurement uncertainty for the conducted measurement. Refer to [Appendix A.3](#) for more information on conducted sensitivity measurements and cabling setups.

The radiated GPS L1 sensitivity measurement shall be performed at the position/polarization where the peak C/N_0 value was obtained in the upper hemisphere. The GPS satellite simulator shall implement GNSS Scenario #1 as defined in 3GPP TS 37.571-5 Section 6.2.1.2.1 for satellites simulated for 3GPP TS 37.571-1 subclause 7, sub-test 1. The scenario shall be reset before the initial satellites become no longer visible. The scenario shall be executed as required in Section 7.1.1 Sub-Test Number 1 of 3GPP TS 37.571-1 except that random errors shall not be applied to the UE locations and the alternating locations requirement shall not be implemented. Unless otherwise specified, the latest versions of the referenced 3GPP documents shall be used.

For GLONASS, the radiated sensitivity measurement shall be performed at the position/polarization where the peak C/N_0 value was obtained in the upper hemisphere during the radiated 3D C/N_0 pattern measurement for GPS L1. The GLONASS satellite simulator shall implement GNSS Scenario #1 as defined in 3GPP TS 37.571-5 Section 6.2.1.2.1 for satellites simulated for 3GPP TS 37.571-1 subclause 7, sub-test 5. The scenario shall be reset before the viable running time expires as defined in the same clause. The scenario shall be executed as required in Section 7.1.1 Sub-Test Number 5 of 3GPP TS 37.571-1 except that random errors shall not be applied to the UE locations and the alternating locations requirement shall not be implemented.

The 1 dB test tolerance or test parameter relaxation for the absolute GPS L1 signal level in C.2.1 in 3GPP TS 37.571-1 shall not be used in reporting the sensitivity measurement results.

R.6.1 Stand-alone GNSS Acquisition Sensitivity Method

The GNSS information shall be cleared prior to every location attempt.

The GPS L1 test parameters are defined below in [Table R-2](#).

TABLE R-2 GPS L1 TEST PARAMETERS FOR STAND-ALONE GNSS ACQUISITION SENSITIVITY METHOD

Test Parameter Description	Test Parameter Settings
Number of satellites	8
HDOP range	1.1 to 1.6
Propagation conditions	AWGN
GPS L1 time assistance	Coarse, ± 2 s
EUT response time	120 seconds
Success rate	38 successful fixes with the necessary accuracy out of 40 attempts (95%)
Position accuracy	101.3 m

The satellite power levels for the sensitivity test are such that there will be one GPS L1 satellite, which transmits 5 dB higher than the other satellites. The reported sensitivity level will be based on the power of the weaker satellites. The above clarification means that, at signal levels -141 dBm and -146 dBm will lead to a sensitivity level report of -146 dBm, rather than -147 dBm.

The GLONASS test parameters are defined below in [Table R-3](#).

TABLE R-3 GLONASS TEST PARAMETERS FOR STAND-ALONE GNSS ACQUISITION SENSITIVITY

Test Parameter Description	Test Parameter Settings
Number of satellites	6
HDOP range	1.4 to 2.1
Propagation conditions	AWGN
GNSS time assistance	Coarse, ± 2 s
EUT response time	120 seconds
Success rate	38 successful fixes with the necessary accuracy out of 40 attempts (95%)
Position accuracy	101.3 m

R.6.2 Stand-alone GNSS Tracking Sensitivity Method

The satellite power levels for the GPS L1 and GLONASS sensitivity tests are such that all the GPS L1 and GLONASS satellites will transmit the same power. Note that this is different than what is required in [Appendix R.6.1](#).

For GPS L1 and GLONASS sensitivity tests, at each power level, to ensure that GNSS receiver has properly adjusted to the new power level, wait 10 seconds after changing the power level, and then monitor C/N_0 values. Average the satellites in the measurement report. C/N_0 results may be considered outliers and removed from the average when the results deviate (higher or lower) by more than 3 dB from the median C/N_0 of the reported satellites. Although outside the recommendations outlined in this test procedure it is possible to improve measurement time by reducing the deviation to 1.5 dB when identifying outliers. The sensitivity passes if 10 measurement reports with 4 or more satellites are received and the deviation in the average C/N_0 is less than 1 dB. . A maximum of 20 consecutive reports can be monitored and if the pass criteria is not achieved within those 20 reports, then the sensitivity fails.

If at any point during the sensitivity search, the receiver reports that no satellites are visible during the sensitivity search, the signal level can be increased (e.g. -130 dBm) and dwell time increased so that the GNSS receiver can regain lock and then the sensitivity search can continue. Note that when adjusting the power level in large steps the response time for accurate C/N_0 for the GNSS receiver increases and the probability that the receiver will lose lock increases.

As with any offset method, as the number of offset points increases, the measurement uncertainty decreases. Four offset points are recommended for this method.

For GPS L1 sensitivity measurements, the sensitivity threshold shall be the minimum GPS L1 signal level at which 4 or more GPS L1 satellites are observed by the GPS L1 receiver.

For GLONASS sensitivity measurements, the sensitivity threshold shall be the minimum GNSS signal level at which at least 4 satellites, either GPS L1 or GLONASS, are observed by the GNSS receiver.

R.7 Criteria

Results shall be reported as specified in [Appendix B](#) using the figures of merit given in [Appendix B.3](#). [Table R-4](#) and [Table R-5](#) contain the pass/fail limits for stand-alone GNSS.

TABLE R-4 STAND-ALONE GPS L1 MAXIMUM TIS/UHIS/PIGS LEVEL (IN DBM) REQUIREMENTS FOR THE PRIMARY MECHANICAL MODE¹

Stand-Alone GPS L1 Maximum TIS/UHIS/PIGS Level (in dBm) Requirements for the Primary Mechanical Mode ¹							
Stand-Alone Method	Device Width (mm) ²	BHHL and BHHR			HL and HR		
		TIS	UHIS	PIGS	TIS	UHIS	PIGS
Acquisition Sensitivity	≤72	TBD	TBD	TBD	TBD	TBD	TBD
	>72	TBD	TBD	TBD	TBD	TBD	TBD
Tracking Sensitivity	≤72	TBD	TBD	TBD	TBD	TBD	TBD
	>72	TBD	TBD	TBD	TBD	TBD	TBD

Note 1: Primary Mechanical Mode refers to device configured in preferred mode per manufacturer instructions (typically means antenna extended, fold or portrait slide open, but depends on form factor).
Note 2: Differences between requirements for devices wider and narrower than 72 mm reflect observed differences in OTA performance with different hand phantoms of up to 6 dB.

TABLE R-5 STAND-ALONE GLONASS MAXIMUM TIS/UHIS/PIGS LEVEL (IN DBM) REQUIREMENTS FOR THE PRIMARY MECHANICAL MODE¹

Stand-Alone GLONASS Maximum TIS/UHIS/PIGS Level (in dBm) Requirements for the Primary Mechanical Mode ¹							
Stand-Alone Method	Device Width (mm) ²	BHHL and BHHR			HL and HR		
		TIS	UHIS	PIGS	TIS	UHIS	PIGS
Acquisition Sensitivity	≤72	TBD	TBD	TBD	TBD	TBD	TBD
	>72	TBD	TBD	TBD	TBD	TBD	TBD
Tracking Sensitivity	≤72	TBD	TBD	TBD	TBD	TBD	TBD
	>72	TBD	TBD	TBD	TBD	TBD	TBD

Note 1: Primary Mechanical Mode refers to device configured in preferred mode per manufacturer instructions (typically means antenna extended, fold or portrait slide open, but depends on form factor).
Note 2: Differences between requirements for devices wider and narrower than 72 mm reflect observed differences in OTA performance with different hand phantoms of up to 6 dB.

R.8 Reporting of Test Results

These are the stand-alone GNSS OTA tables to be used for recording results for test reports.

TABLE R-6 STAND-ALONE GPS L1 MAXIMUM TIS/UHIS/PIGS LEVEL (IN DBM) REQUIREMENTS FOR THE PRIMARY MECHANICAL MODE¹

Reference OTA Test Plan Table R-4																		
Stand-Alone Method	HL									HR								
	TIS			UHIS			PIGS			TIS			UHIS			PIGS		
	Limit (dBm) ²	Test Results (dBm)	Pass / Fail / Info	Limit (dBm) ²	Test Results (dBm)	Pass / Fail / Info	Limit (dBm) ²	Test Results (dBm)	Pass / Fail / Info	Limit (dBm) ²	Test Results (dBm)	Pass / Fail / Info	Limit (dBm) ²	Test Results (dBm)	Pass / Fail / Info	Limit (dBm) ²	Test Results (dBm)	Pass / Fail / Info
Acquisition Sensitivity	TBD			TBD			TBD			TBD			TBD			TBD		
Tracking Sensitivity	TBD			TBD			TBD			TBD			TBD			TBD		
Stand-Alone Method	BHHL									BHHR								
	TIS			UHIS			PIGS			TIS			UHIS			PIGS		
	Limit (dBm) ²	Test Results (dBm)	Pass / Fail / Info	Limit (dBm) ²	Test Results (dBm)	Pass / Fail / Info	Limit (dBm) ²	Test Results (dBm)	Pass / Fail / Info	Limit (dBm) ²	Test Results (dBm)	Pass / Fail / Info	Limit (dBm) ²	Test Results (dBm)	Pass / Fail / Info	Limit (dBm) ²	Test Results (dBm)	Pass / Fail / Info
Acquisition Sensitivity	TBD			TBD			TBD			TBD			TBD			TBD		
Tracking Sensitivity	TBD			TBD			TBD			TBD			TBD			TBD		
<p>Note 1: Primary Mechanical Mode refers to device configured in preferred mode per manufacturer instructions (typically means antenna extended, fold or portrait slide open, but depends on form factor).</p> <p>Note 2: The appropriate limits shall be populated in this column based on the device width.</p>																		

TABLE R-7 STAND-ALONE GLONASS MAXIMUM TIS/UHIS/PIGS LEVEL REQUIREMENTS FOR THE PRIMARY MECHANICAL MODE¹

Reference OTA Test Plan Table R-5																		
Stand-Alone Method	HL									HR								
	TIS			UHIS			PIGS			TIS			UHIS			PIGS		
	Limit (dBm) ²	Test Results (dBm)	Pass / Fail / Info	Limit (dBm) ²	Test Results (dBm)	Pass / Fail / Info	Limit (dBm) ²	Test Results (dBm)	Pass / Fail / Info	Limit (dBm) ²	Test Results (dBm)	Pass / Fail / Info	Limit (dBm) ²	Test Results (dBm)	Pass / Fail / Info	Limit (dBm) ²	Test Results (dBm)	Pass / Fail / Info
Acquisition Sensitivity	TBD			TBD			TBD			TBD			TBD			TBD		
Tracking Sensitivity	TBD			TBD			TBD			TBD			TBD			TBD		
Stand-Alone Method	BHHL									BHHR								
	TIS			UHIS			PIGS			TIS			UHIS			PIGS		
	Limit (dBm) ²	Test Results (dBm)	Pass / Fail / Info	Limit (dBm) ²	Test Results (dBm)	Pass / Fail / Info	Limit (dBm) ²	Test Results (dBm)	Pass / Fail / Info	Limit (dBm) ²	Test Results (dBm)	Pass / Fail / Info	Limit (dBm) ²	Test Results (dBm)	Pass / Fail / Info	Limit (dBm) ²	Test Results (dBm)	Pass / Fail / Info
Acquisition Sensitivity	TBD			TBD			TBD			TBD			TBD			TBD		
Tracking Sensitivity	TBD			TBD			TBD			TBD			TBD			TBD		

Note 1: Primary Mechanical Mode refers to device configured in preferred mode per manufacturer instructions (typically means antenna extended, fold or portrait slide open, but depends on form factor).

Note 2: The appropriate limits shall be populated in this column based on the device width.

Appendix S Selection of Test Channels for LTE CA OTA Testing (Informative)

S.1 Purpose

This Appendix describes the various guidelines used in selecting channels for CA combinations. These guidelines are not normative but should be useful in identifying test channels for new CA combinations.

S.2 Examples

Example 1 (2 CA Inter-Band TRP): In this example channel 2450 is chosen to maximize the span between the PCC under test and the SCC.

CA_2A-5A	2	5	10	10	18650	2450	12 RB with RBstart=0	N/A	N/A
			10	10	18900	2450	12 RB with RBstart=19	N/A	N/A
			10	10	19150	2450	12 RB with RBstart=38	N/A	N/A

Example 2 (3 CA Inter-Band TRP): In this example, the SCC's are chosen to maximize the span since the PCC band falls between the SCC bands.

CA_2A-4A-5A	2	SCC1=4 SCC2=5	10	SCC1=10 SCC2=10	18650	SCC1=2350 SCC2=2450	12 RB with RBstart=0	N/A	N/A
					18900	SCC1=2350 SCC2=2450	12 RB with RBstart=19	N/A	N/A
					19150	SCC1=2350 SCC2=2450	12 RB with RBstart=38	N/A	N/A

Example 3 (3 CA Inter-Band TRP): In this example, SCC2 is chosen to maximize the span between the PCC under test and SCC2. The band for SCC1 falls in between the PCC band and the SCC2 band making the selection of the SCC1 channel arbitrary. In this example, the SCC1 was chosen to force the antenna to tune across the entirety of bands 2 and 4.

CA_13A-2A-4A	13	CA_13A-2A-4A	10	SCC1=10 SCC2=10	23230	SCC1=650	12 RB with RBstart=0	N/A	N/A
						SCC2=2350			
					23230	SCC1=650	12 RB with RBstart=19	N/A	N/A
						SCC2=2350			
					23230	SCC1=650	12 RB with RBstart=38	N/A	N/A
						SCC2=2350			

Example 4 (3 CA Inter-Band TRP): In this example, SCC2 is chosen to maximize the span between the PCC under test and SCC2. The band for SCC1 falls in between the PCC band and the SCC2 band making the selection of the SCC1 channel arbitrary. In this example, the SCC1 was chosen to force the antenna to tune across the entirety of band 4.

CA_13A-4A-4A	13	SCC1=4 SCC2=4	10	SCC1=10 SCC2=10	23230	SCC1=2000	12 RB with RBstart=0	N/A	N/A
						SCC2=2350			
					23230	SCC1=2000	12 RB with RBstart=19	N/A	N/A
						SCC2=2350			
					23230	SCC1=2000	12 RB with RBstart=38	N/A	N/A
						SCC2=2350			

Example 5 (3 CA Inter-Band TRP): In this example, SCC1 and SCC2 are chosen to maximize the span between the PCC under test and the intra-band, contiguous combination of SCC1 and SCC2.

CA_2A-66C	2	SCC1=66 SCC2=66	10	SCC1=10 SCC2=20	18650	SCC1=67086	12 RB with RBstart=0	N/A	N/A
						SCC2=67230			
					18900	SCC1=67086	12 RB with RBstart=19	N/A	N/A
						SCC2=67230			
					19150	SCC1=67086	12 RB with RBstart=38	N/A	N/A
						SCC2=67230			

For CA TRP where the PCC and SCC/SCC1 are intra-band, non-contiguous carriers, the following general rule was applied:

TABLE S-1 CA TRP WHERE THE PCC AND SCC/SCC1 ARE INTRA-BAND

PCC	SCC or SCC1
Low Channel	Mid Channel
Mid Channel	High Channel
High Channel	Low Channel

Example 6 (2 CA Intra-Band, Non-Contiguous TRP): In this example, the PCC and SCC channels are chosen based on the rule above in Table S-1

CA_4A-4A	4	4	10	10	20000	2175	12 RB with RBstart=0	N/A	N/A
			10	10	20175	2350	12 RB with RBstart=19	N/A	N/A
			10	10	20350	2000	12 RB with RBstart=38	N/A	N/A

Example 7 (3 CA with Intra-Band, Non-Contiguous component TRP): In this example, the PCC and SCC1 follow the rule above in Table S-1 and the SCC2 is chosen to maximize the frequency span.

CA_4A-4A-5A	4	SCC1=4 SCC2=5	10	SCC1=10 SCC2=10	20000	SCC1=2175	12 RB with RBstart=0	N/A	N/A
						SCC2=2450			
					20175	SCC1=2350	12 RB with RBstart=19	N/A	N/A
						SCC2=2450			
					20350	SCC1=2000	12 RB with RBstart=38	N/A	N/A
						SCC2=2450			

For CA TRP where the PCC and SCC/SCC1 are intra-band, contiguous carriers, the following general rule was applied:

TABLE S-2 CA TRP WHERE THE PCC AND SCC/SCC1 ARE INTRA-BAND

PCC	SCC or SCC1
Low Channel	Low Channel + One Channel
Mid Channel	Mid Channel +/- One Channel
High Channel	High Channel - One Channel

Example 8 (2 CA Intra-Band, Contiguous TRP): In this example, the PCC and SCC channels are chosen based on the rule above in [Table S-2](#).

CA_41C	41	41	20	20	39750	39948	18 RB with RBstart=0	N/A	N/A
			20	20	40620	40422	18 RB with RBstart=41	N/A	N/A
			20	20	41490	41292	18 RB with RBstart=82	N/A	N/A

For CA TIS, the SCC (or SCC's) were generally chosen based on the following rule:

TABLE S-3 CA TIS

PCC	SCC or SCC1	SCC2 (for 3 CA)
Low Channel	Low Channel	Low Channel
Mid Channel	Mid Channel	Mid Channel
High Channel	High Channel	High Channel

Example 9 (2 CA Inter-Band TIS): In this example, the SCC is chosen based on the rule above in [Table S-3](#).

CA_2A-5A	2	5	10	10	650	2450	50 RB with RBstart=0	50 RB with RBstart=0	50 RB with RBstart=0
					900	2525	50 RB with RBstart=0	50 RB with RBstart=0	50 RB with RBstart=0
					1150	2600	50 RB with RBstart=0	50 RB with RBstart=0	50 RB with RBstart=0

Example 10 (3 CA Inter-Band TIS): In this example, the SCC1 and SCC2 are chosen based on the rule above in [Table S-3](#).

CA_2A-4A-5A	2	SCC1=4 SCC2=5	10	SCC1=10 SCC2=10	650	SCC1=2000 SCC2=2450	50 RB with RBstart=0	50 RB with RBstart=0	50 RB with RBstart=0	50 RB with RBstart=0
					900	SCC1=2175 SCC2=2525	50 RB with RBstart=0	50 RB with RBstart=0	50 RB with RBstart=0	50 RB with RBstart=0
						1150	SCC1=2350 SCC2=2600	50 RB with RBstart=0	50 RB with RBstart=0	50 RB with RBstart=0
					50 RB with RBstart=0		50 RB with RBstart=0		50 RB with RBstart=0	

For CA TIS where the PCC and SCC/SCC1 are intra-band, non-contiguous carriers, the same general rule was applied as in TRP in [Table S-1](#).

Example 11 (2 CA Intra-Band, Non-Contiguous TIS): In this example, the PCC and SCC channels are chosen based on the same rule as TRP using [Table S-1](#).

CA_4A-4A	4	4	10	10	2000	2175	50 RB with RBstart=0	50 RB with RBstart=0	50 RB with RBstart=0
					2175	2350	50 RB with RBstart=0	50 RB with RBstart=0	50 RB with RBstart=0
					2350	2000	50 RB with RBstart=0	50 RB with RBstart=0	50 RB with RBstart=0

Example 12 (3 CA with Intra-Band, Non-Contiguous component TIS): In this example, the PCC and SCC1 follow the rule in [Table S-1](#) while SCC2 is chosen based on [Table S-3](#).

CA_4A-4A-5A	4	SCC1=4 SCC2=5	10	SCC1=10 SCC2=10	2000	SCC1=2175	50 RB with RBstart=0	50 RB with RBstart=0	50 RB with RBstart=0	50 RB with RBstart=0
						SCC2=2450				
					2175	SCC1=2350	50 RB with RBstart=0	50 RB with RBstart=0	50 RB with RBstart=0	50 RB with RBstart=0
						SCC2=2525				
					2350	SCC1=2000	50 RB with RBstart=0	50 RB with RBstart=0	50 RB with RBstart=0	50 RB with RBstart=0
						SCC2=2600				

Example 13 (3 CA with Intra-Band, Non-Contiguous component TIS): In this example, the intra-band, non-contiguous SCC1 and SCC2 follow the rule in [Table 1](#) while the PCC is chosen based on [Table S-3](#).

CA_5A-4A-4A	5	SCC1=4 SCC2=4	10	SCC1=10 SCC2=10	2450	SCC1=2000	25 RB with RBstart=25	50 RB with RBstart=0	50 RB with RBstart=0	50 RB with RBstart=0
						SCC2=2175				
					2525	SCC1=2175	25 RB with RBstart=25	50 RB with RBstart=0	50 RB with RBstart=0	50 RB with RBstart=0
						SCC2=2350				
					2600	SCC1=2350	25 RB with RBstart=25	50 RB with RBstart=0	50 RB with RBstart=0	50 RB with RBstart=0
						SCC2=2000				

For CA TIS where the PCC and SCC/SCC1 are intra-band, contiguous carriers, the same general rule was applied as in TRP in [Table S-2](#).

Example 14 (2 CA Intra-Band, Contiguous TIS): In this example, the PCC and SCC channels are chosen based on the same rule as TRP using [Table S-2](#). However, note that the high channel PCC and SCC are reversed from [Table S-2](#) because uplink operation is only allowed in the lower 70 MHz of Band 66 (exceptions for Band 66 are discussed in more detail in the next section).

CA_66C	66	66	20	20	66536	66734	100 RB with RBstart=0	100 RB with RBstart=0	100 RB with RBstart=0
			20	20	66786	66984	100 RB with RBstart=0	100 RB with RBstart=0	100 RB with RBstart=0
			20	20	67036	67234	100 RB with RBstart=0	100 RB with RBstart=0	100 RB with RBstart=0

Example 15 (3 CA with Intra-Band, Contiguous component TIS): In this example, the PCC and SCC1 follow the rule in [Table S-2](#) while SCC2 is chosen based on [Table S-3](#). However, note that the high channel PCC and SCC1 are reversed from [Table S-2](#) because uplink operation is only allowed in the lower 70 MHz of Band 66 (exceptions for Band 66 are discussed in more detail in the next section).

CA_66C-5A	66	SCC1=66 SCC2=5	20	SCC1=20 SCC2=10	66536	SCC1=66734	100 RB with RBstart=0	100 RB with RBstart=0	100 RB with RBstart=0	50 RB with RBstart=0
						SCC2=2450				
					66786	SCC1=66984	100 RB with RBstart=0	100 RB with RBstart=0	100 RB with RBstart=0	50 RB with RBstart=0
						SCC2=2525				
					67036	SCC1=67234	100 RB with RBstart=0	100 RB with RBstart=0	100 RB with RBstart=0	50 RB with RBstart=0
						SCC2=2600				

Example 16 (3 CA with Intra-Band, Contiguous component TIS): In this example, the intra-band, non-contiguous SCC1 and SCC2 follow the rule in [Table S-2](#) while the PCC is chosen based on [Table S-3](#).

CA_5A-66C	5	SCC1=66 SCC2=66	10	SCC1=20 SCC2=20	2450	SCC1=66536	25 RB with RBstart=25	50 RB with RBstart=0	100 RB with RBstart=0	100 RB with RBstart=0
						SCC2=66734				
					2525	SCC1=66786	25 RB with RBstart=25	50 RB with RBstart=0	100 RB with RBstart=0	100 RB with RBstart=0
						SCC2=66984				
					2600	SCC1=67036	25 RB with RBstart=25	50 RB with RBstart=0	100 RB with RBstart=0	100 RB with RBstart=0
						SCC2=67234				

Exceptions:

Some notable exceptions to the rules above include:

- TIS for 2A-2A and 5A-5A includes an extra test point due to desense when the SCC carrier frequency is below the PCC carrier frequency. These additional test points are based on the 3GPP TS 36.101 specifications for 2A-2A and 5A-5A.
- In some cases there are fewer than three test points depending on the size of the band and the channel bandwidth used for testing, e.g., 5B, 66D (TIS).
- Testing for 5A-5A uses 5 MHz channels instead of the normal 10 MHz based on expected deployment scenarios and the size of the band.
- Band 66 created deviations due to the nature of Band 66 having FDD operation in the lower 70 MHz of the band but downlink only operation in the upper 20 MHz of the band. These deviations are summarized below:
 - The PCC for the high channel is always at the upper edge of the 70 MHz FDD portion of the band.
 - For TRP, [Table S-1](#) is replaced with [Table S-4](#) below for Band 66 intra-band, non-contiguous carriers (when the PCC is in Band 66):

TABLE S-4 BAND 66 INTRA-BAND, NON-CONTIGUOUS CARRIERS (WHEN THE PCC IS IN BAND 66)

PCC	SCC or SCC1
Low Channel	High Channel
Mid FDD Channel	High Channel
High FDD Channel	Low Channel

Example 17 (2 CA Intra-Band, Non-Contiguous TRP for Band 66): In this example, the PCC and SCC channels are chosen based on the rules in Table S-4.

CA_66A-66A	66	66	10	10	132022	67286	12 RB with RBstart=0	N/A	N/A
			10	10	132322	67286	12 RB with RBstart=19	N/A	N/A
			10	10	132622	66486	12 RB with RBstart=38	N/A	N/A

Example 18 (3 CA with Intra-Band, Non-Contiguous component TRP for Band 66): In this example, the PCC and SCC1 follow the rule in Table S-4 while SCC2 is chosen to maximize the frequency span.

CA_66A-66A-5A	66	SCC1=66 SCC2=5	10	SCC1=10 SCC2=10	132022	SCC1=67286	12 RB with RBstart=0	N/A	N/A
						SCC2=2450			
					132322	SCC1=67286	12 RB with RBstart=19	N/A	N/A
						SCC2=2450			
					132622	SCC1=66486	12 RB with RBstart=38	N/A	N/A
						SCC2=2450			

For TIS, Table S-1 is replaced with Table S-5 below for Band 66 intra-band, non-contiguous carriers:

TABLE S-5 BAND 66 INTRA-BAND, NON-CONTIGUOUS CARRIERS

PCC	SCC or SCC1
Low Channel	High Channel
Low Channel	High FDD Channel*
Mid FDD Channel	Low Channel
High FDD Channel	Mid Channel

* NOTE: Only the "High FDD Channel" SCC is tested for this test point.

Example 19 (2 CA Intra-Band, Contiguous TIS for Band 66): In this example, the PCC and SCC channels are chosen based on the rule in [Table S-5](#) Note that for the test point in yellow, TIS testing is only required on the SCC.

CA_66A-66A	66	66	10	10	66486	67286	50 RB with RBstart=0	50 RB with RBstart=0	50 RB with RBstart=0
					66486	67086	50 RB with RBstart=0	50 RB with RBstart=0	50 RB with RBstart=0
					66786	66486	50 RB with RBstart=0	50 RB with RBstart=0	50 RB with RBstart=0
					67086	66786	50 RB with RBstart=0	50 RB with RBstart=0	50 RB with RBstart=0

Example 20 (3 CA with Intra-Band, Non-Contiguous component TIS for Band 66): In this example, the PCC and SCC1 follow the rule in [Table S-5](#) while SCC2 is chosen based on [Table S-3](#). Note that for the test point in yellow, TIS testing is only required on the SCC1 so the selection of SCC2 is arbitrary.

CA_66A-66A-5A	66	SCC1=66 SCC2=5	10	SCC1=10 SCC2=10	66486	SCC1=67286	50 RB with RBstart=0	50 RB with RBstart=0	50 RB with RBstart=0	50 RB with RBstart=0
						SCC2=2450				
					66486	SCC1=67086	50 RB with RBstart=0	50 RB with RBstart=0	50 RB with RBstart=0	50 RB with RBstart=0
						SCC2=2525				
					66786	SCC1=66486	50 RB with RBstart=0	50 RB with RBstart=0	50 RB with RBstart=0	50 RB with RBstart=0
						SCC2=2525				
					67086	SCC1=66786	50 RB with RBstart=0	50 RB with RBstart=0	50 RB with RBstart=0	50 RB with RBstart=0
						SCC2=2600				

Example 21 (3 CA with Intra-Band, Non-Contiguous component TIS for Band 66): In this example, the intra-band, non-contiguous SCC1 and SCC2 follow the rule in [Table S-5](#) while the PCC is chosen based on [Table S-3](#) Note that for the test point in yellow, TIS testing is only required on the SCC2 so the selection of the PCC is arbitrary. Note that for the test point in blue, the high channel for Band 66 was used (as opposed to the high FDD channel) since both Band 66 carriers are SCC's.

CA_5A-66A-66A	5	SCC1=66 SCC2=66	10	SCC1=10 SCC2=10	2450	SCC1=66486	25 RB with RBstart=25	50 RB with RBstart=0	50 RB with RBstart=0	50 RB with RBstart=0
						SCC2=67286				
					2525	SCC1=66486	25 RB with RBstart=25	50 RB with RBstart=0	50 RB with RBstart=0	50 RB with RBstart=0
						SCC2=67086				
					2525	SCC1=66786	25 RB with RBstart=25	50 RB with RBstart=0	50 RB with RBstart=0	50 RB with RBstart=0
						SCC2=66486				
					2600	SCC1=67286	25 RB with RBstart=25	50 RB with RBstart=0	50 RB with RBstart=0	50 RB with RBstart=0
						SCC2=66786				

Appendix T Bluetooth Basic Rate (Informative)

T.1 Bluetooth Basic Rate TRP Test Procedure

This procedure is intended for Bluetooth Basic Rate EUTs.

The measurement site and EUT shall be configured as specified in [Appendix A](#). The power radiated by the EUT shall be measured using a calibrated and accurate RF measuring instrument capable of measuring peak and average power across bursts. Communication settings shall be the same as the BT SIG RF specification Section 4.5.1, test case RF/TRM/CA/BV-01-C, with the following settings/exceptions summarized in [Table T-1](#).

TABLE T-1 BLUETOOTH BASIC RATE COMMUNICATION SETTINGS FOR TRP

Test Mode	Loop Back / TX Mode
TX Power	UE transmits at max power
Hopping	Off
Packet Type	DH-1
Payload Length	27 bytes
Payload Type	PRBS 9

The settings for the RF TX measurement equipment shall be equivalent to the settings in [Table T-2](#).

TABLE T-2 RF TX MEASUREMENT EQUIPMENT SETTINGS FOR BLUETOOTH BASIC RATE

Span	Zero span
Resolution Bandwidth	3 MHz
Video Bandwidth	3 MHz
Detector	Peak
Sweep Time	1 ms
Trigger	external (from signaling unit)
Reported Power	average power over at least 20% to 80% of the duration of the burst
Number of samples to average	10

The conducted power of the EUT shall also be measured at the antenna connector, if available, on all applicable frequencies. It is preferable that the EUT be the same as utilized for the TRP measurements. However, if the EUT does not readily support an antenna port for conducted measurements, a separate modified EUT may be provided for all conducted measurements. If no connector is available, the conducted power measurement is not required. Ideally, the power measurement will be performed with the same instrumentation in an equivalent configuration in order to minimize the measurement

uncertainty involved. A different power measurement device may be used as long as any differences in absolute measurement accuracy are accounted for, either in corrections to the recorded power or increased reported measurement uncertainty for the conducted measurement. Refer to [Appendix A.3](#) for more information on conducted power measurements and cabling setups.

Tests shall be performed with these settings:

- Communication settings equivalent to those shown in [Table T-1](#)
- RF TX measurement equipment settings equivalent to those shown in [Table T-2](#)
- The low, middle and high channels as defined in [Table T-3](#)

TABLE T-3 BLUETOOTH BASIC RATE TEST CHANNELS FOR TRP USING “LOOP BACK” OR “TX MODE”

Loop Back		Low	Mid	High
TX (EUT)	Frequency (MHz)	2402	2441	2480
	Channel	0	39	78
RX (EUT)	Frequency (MHz)	2480	2402	2402
	Channel	78	0	0

Head and hand phantom, hand phantom only, wrist-worn and/or free-space testing shall be conducted based on device type, as specified in [Appendix O](#). Refer to [Appendix C](#) for head/hand testing requirements and [Appendix Q](#) for wrist-worn testing requirements.

T.2 OTA Reporting for Bluetooth Basic Rate TRP

Results shall be reported as specified below using the figures of merit given in [Appendix B.3](#).

Table T-4 contains the OTA test results for Bluetooth Basic Rate. Reports shall include results for free-space, head/hand and wrist-worn configurations (if applicable) across all channels measured with the EUT antenna extended and retracted (if applicable).

TABLE T-4 BLUETOOTH BASIC RATE TRP TEST RESULTS

TRP								
Channel	Frequency (MHz)	FS	HL	HR	BHHL	BHHR	WL	WR
0	2402							
39	2441							
78	2480							

T.3 Bluetooth Basic Rate TIS Test Procedure

Bluetooth Basic Rate Receiver Sensitivity measurements shall be performed using a communication tester to determine the EUT's receiver sensitivity by reporting the minimum forward-link power resulting

in 0.1% Bit Error Rate (BER) with intentionally degraded “Dirty Packets”. Refer to [Appendix A](#) for set-up illustrations. Communication settings shall be the same as the BT SIG RF specification Section 4.6.1, test case RF/RCV/CA/BV-01-C, with the following settings/exceptions summarized in [Table T-5](#).

TABLE T-5 BLUETOOTH BASIC RATE COMMUNICATION SETTINGS FOR TIS

Test Mode	Loop Back
TX Power	UE transmits at max power
Hopping	Off
Packet Type	DH-1
Payload Length	27 bytes
Payload Type	PRBS 9
Dirty TX	On

The settings for the RF RX sensitivity measurement are defined in [Table T-6](#).

TABLE T-6 RF RX SENSITIVITY MEASUREMENT FOR BLUETOOTH BASIC RATE

Error Rate Measurement	BER
BER Threshold	0.10%
Number of Packets	500

[Table T-7](#) lists the channel configurations to be used for TIS testing.

TABLE T-7 BLUETOOTH BASIC RATE TEST CHANNELS FOR TIS USING “LOOP BACK”

Loop Back		Low	Mid	High
RX (EUT)	Frequency (MHz)	2402	2441	2480
	Channel	0	39	78
TX (EUT)	Frequency (MHz)	2480	2402	2402
	Channel	78	0	0

The conducted sensitivity of the EUT shall also be measured at the antenna connector, if available, at all applicable frequencies. It is preferable that the EUT be the same as utilized for the TIS measurements. However, if the EUT does not readily support an antenna port for conducted measurements, a separate modified EUT may be provided for all conducted measurements. If no connector is available, the conducted sensitivity measurement is not required. Ideally, the sensitivity measurement will be performed with the same instrumentation in an equivalent configuration in order to minimize the measurement uncertainty involved. A different sensitivity measurement device may be used as long as any differences in absolute measurement accuracy are accounted for, either in corrections to the recorded sensitivity level or increased reported measurement uncertainty for the conducted measurement. Refer to [Appendix A.3](#) for more information on conducted sensitivity measurements and cabling setups.

TIS shall be fully measured as described above and calculated pursuant to [Appendix B.3](#) for the 3 channels (low, middle and high) specified in [Table T-7](#).

Receiver sensitivity testing on intermediate channels is not required by this test procedure.

T.4 OTA Reporting for Bluetooth Basic Rate TIS

Results shall be reported as specified below using the figures of merit given in [Appendix B.3](#). [Table T-8](#) contains the TIS test results for Bluetooth Basic Rate. Reports shall include results for free-space, head/hand and wrist-worn configurations (if applicable) across all channels measured.

TABLE T-8 BLUETOOTH BASIC RATE TIS TEST RESULTS

TIS								
Channel	Frequency (MHz)	FS	HL	HR	BHHL	BHHR	WL	WR
0	2402							
39	2441							
78	2480							

Appendix U Phantom Material Selection Based on Test Frequency

The hand phantom dielectric parameter requirements are stated in [Appendix C.4.1](#), and these requirements are also used for the forearm phantom. Currently, a single hand phantom material is not available that meets the dielectric parameters over the 300 MHz to 6 GHz range. Hand phantom materials exist which meet the dielectric parameters for 1) all defined test frequencies below 3 GHz range and 2) all defined test frequencies above 3 GHz.

The head phantom dielectric parameter requirements are stated in [Appendix C.2.2](#). Currently, a single head phantom material is available that meets the dielectric parameters over the 600 MHz to 6 GHz range. At this time, the head phantom material shall comply with the dielectric parameter requirements for all band/protocols used in a test, even the band/protocols not being directly measured.

The hand phantom material shall always be selected such that its dielectric parameters meet the requirements over the frequency of the band/protocol being measured in any given test. If LTE band 13 (~700 MHz) is being measured in the head and hand or hand only position, then the hand phantom material for below 3 GHz shall be used. If LTE band 48 (3.6 GHz) is being measured in the wrist-worn position, then the hand phantom material for above 3 GHz shall be used.

There are test cases where two or more bands/protocols are operational, however there is always only one band/protocol being measured. For example, in LTE LAA with the PCC in Band 13, one band is at 700 MHz, and the other band is at 5 GHz. For the hand only use case, when the PCC in band 13 is being measured then the below 3 GHz hand phantom material shall be used and when the SCC in band 46 is being measured then the above 3 GHz hand phantom shall be used. In the case where intermediate channel relative sensitivity is being measured, the band/protocol whose sensitivity is being measured is the band/protocol that is used to select the hand phantom material. In the above example, when band 46 intermediate channel relative sensitivity is measured, then the above 3 GHz hand phantom shall be used even though the LTE band 13 interferer is at 700 MHz.

While it is known that the use of incorrect dielectric material in the phantoms will affect the radiated performance of interfering RF signals, the impact has been assessed to be tolerable and no additional measurement uncertainty shall be assessed when a phantom with dielectric material, which is not compliant over the frequency band of an interferer, is used to measure another band/protocol for which the dielectric material is compliant.

Appendix V ZigBee (Informative)

V.1 ZigBee TRP Test Procedure

The measurement site and EUT shall be configured as specified in [Appendix A](#). The transmit power level of the DUT to be used for TRP testing shall be at the level intended for the device to be used in the field, and subject to the specific limits the DUT was tested and approved for during regulatory testing (e.g., FCC).

- The DUT shall be tested in its intended mechanical mode and form factor in free space condition.
- It shall be declared which is the power mode: AC mains, barrel batteries (e.g., AA, AAA, CR2), and coin cell batteries (e.g., CR2032)
- Battery-powered devices should be able to complete the full TRP/TIS tests on 4 batteries or less.
- For TRP/TIS testing purposes DUTs should support non-sleepy mode, in order to minimize test times.
- Non-fixed antenna diversity behaves as one antenna.
- Test firmware running on DUT, which is added for testing purposes only and removed for production.

The communication module settings shall be as per [Appendix V.4](#).

1. Measure free space effective isotropic radiated power (EIRP) pattern.
2. Calculate TRP using EIRP pattern.
3. Repeat for at least the channels defined in [Table V-2](#) in which the DUT supports.

TABLE V-1 SPECTRUM ANALYZER SETTINGS FOR ZIGBEE

Span	3 MHz
Resolution Bandwidth (RBW)	100 kHz
Video Bandwidth (VBW)	10 MHz
Sweep Time	100 ms
RMS Detector	Enabled
Data Points	501
Data Duration	1500 ms
Integrated Channel Power	Enabled
Attenuation	Auto
Channels: as defined in Section	Table V-2

TABLE V-2 ZIGBEE CHANNEL SETTINGS

Channel	Frequency
0	868
1	906
4	912
7	918
10	924
11	2405
15	2425
20	2450
25	2475

To provide a consistent basis for comparison and a balance between setup efforts and actual test time the following channels have been selected as the minimum set of channels to be tested for TRP and TIS. Additional channels as determined by the manufacturer (device, platform, model, or product) may be optionally tested as well. Only the bands supported by the device shall be tested (either in the 868 MHz, 915 MHz, and/or 2.4 GHz range).

As shown in [Figure V-1](#) TRP measurements utilize the uplink path through the measurement antenna; measurements are performed on the spectrum analyzer. Testing is done for both vertical and horizontal polarization of the measurement antenna.

FIGURE V-1 TRP BLOCK DIAGRAM SET UP FOR ZIGBEE

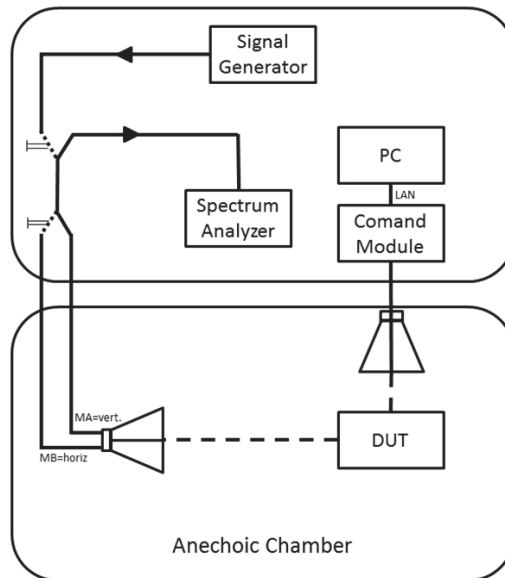

V.2 ZigBee TIS Test Procedure

The measurement site and EUT shall be configured as specified in [Appendix A](#). The DUT is placed in a free-space holder. Communication with the host controller is automatically established via communication antenna inside the chamber. The DUT is brought to the required test channel and output power level through the host controller.

TIS measurements are performed using the Receive Signal Strength (RSS) method. The method shall use the following four steps using RSSI values:

1. RSS pattern measurements
2. RSS pattern linearization
3. Sensitivity search
4. TIS calculation

RSSI values are obtained through ZigBee host from the DUT measurement reports, the TIS test case flow is illustrated using the commands from [Appendix V.4](#).

The Signal Generator: DUT shall receive output from a Signal Generator capable of generating digitally modulated radio frequency signals for band of operation.

The Signal Generator shall be configured to transmit a standard conforming signal and packet with an arbitrary payload and correct CRC with the following parameters:

Using the PSDU generation approach described in clause T.5 Test Case Command Flow

- Number of (PSDU) bits: 20x8
- Phase continuous bit pattern

- Modulation Specifics:
- Offset Quadrature Phase Shift Keying (O-QPSK)
- Pulse Shaping: Half Sine Pulse Shaping

TABLE V-3 ZIGBEE PARAMETER SETTINGS FOR RSS METHOD

Packets during fine steps	2500
RSS Measurement Packets	10
Packets during course step	25
Fine Step Size	0.5 dB
Non-protocol Packets	random # between 2500 and 3500
RSS Data Duration	1500 ms
Channels	Table V-2

1. Measure free space effective isotropic sensitivity (EIS) pattern, Adjust the downlink signal level until the PER is 0.04%. The downlink step size shall be no more than 0.5 dB when the downlink power is near sensitivity.
2. Calculate using EIS pattern,
3. Repeat for at least the channels defined in [Table V-2](#) in which the DUT supports.

As shown in [Figure V-2](#), TIS measurements utilize the downlink path from the ESG through the measurement antenna; measurement reports are recorded at the DUT in terms of RSSI. Testing is done for both vertical and horizontal polarization of the measurement antenna.

FIGURE V-2 TIS BLOCK DIAGRAM SET UP FOR ZIGBEE

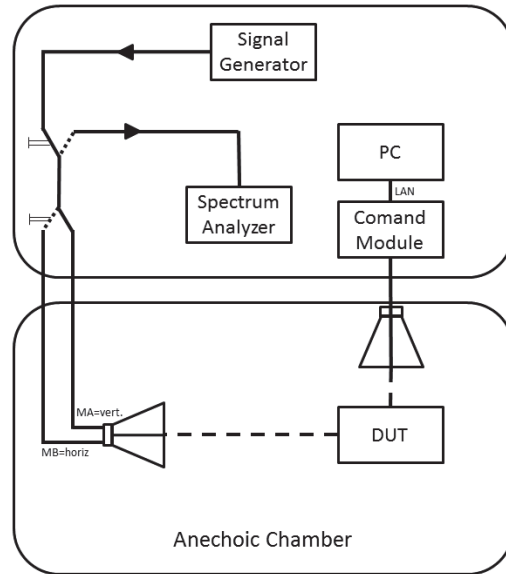

V.3 ZigBee Reporting the Results

This document provides details for test equipment and device manufacturers of the exact packets and contents exchanged over the air during a TRP/TIS performance test for ZigBee devices.

Commands are sent OTA between a command module and a DUT as per [Appendix V.4](#).

TABLE V-4 ZIGBEE TOTAL RADIATED POWER

Band	Ch.	Freq. (MHz)	Cond. Power (dBm)	TRP (dBm)	NHPRP ± 45° (dBm)	NHPRP ± 30° (dBm)
				FS	FS	FS
868 MHz	0	868				
915 MHz	1	906				
915 MHz	4	912				
915 MHz	7	918				
915 MHz	10	924				
2.4 GHz	11	2405				
2.4 GHz	15	2425				
2.4 GHz	20	2450				
2.4 GHz	25	2475				

TABLE V-5 ZIGBEE TOTAL ISOTROPIC SENSITIVITY

Band	Ch.	Freq. (MHz)	Cond. Sensitivity (dBm)	TIS (dBm)	NHPIS $\pm 45^\circ$ (dBm)	NHPIS $\pm 30^\circ$ (dBm)
				FS	FS	FS
868 MHz	0	868				
915 MHz	1	906				
915 MHz	4	912				
915 MHz	7	918				
915 MHz	10	924				
2.4 GHz	11	2405				
2.4 GHz	15	2425				
2.4 GHz	20	2450				
2.4 GHz	25	2475				

V.4 ZigBee Command Module and Test Case Flow

This section contains a comprehensive list of all commands exchanged between the command module (CMD) and the DUT during TRP/TIS testing.

The contents of these commands fit in the PAYLOAD portion of the frame.

Command IDs 240-250 are reserved.

PING

- COMMAND ID: 0x00
- DIRECTION: CMD->DUT
- PAYLOAD: [0xDE] [0xDE] [0x00] [0x00]
- UPON RECEIPT: DUT will send an ACK

ACK

- COMMAND ID: 0x01
- DIRECTION: DUT->CMD
- PAYLOAD: [0xDE] [0xDE] [0x00] [0x01]
- UPON RECEIPT: CMD will print indication of ACK received
 - "ACK" (failure case - "NO ACK")

SET_CHANNEL

- COMMAND ID: 0x02
- DIRECTION: CMD->DUT
- PAYLOAD: [0xDE] [0xDE] [0x00] [0x02] <channel:3> <channel:2> <channel:1> <channel:0>

- <channel> is a 4 byte octet, which includes both channel page and channel #
- UPON RECEIPT: DUT will set channel

GET_CHANNEL_RESPONSE

- COMMAND ID: 0x04
- DIRECTION: DUT->CMD
- PAYLOAD: [0xDE] [0xDE] [0x00] [0x0x04] <channel:3> <channel:2> <channel:1> <channel:0>
 - <channel> is a 4 byte octet, which includes both channel page and channel #
- UPON RECEIPT: CMD will indicate which GET_CHANNEL_RESPONSE it received as a 4 byte octet
 - channel]0x%x

SET_POWER (for future revision/release)

- COMMAND ID: 0x05
- DIRECTION: CMD->DUT
- PAYLOAD: [0xDE] [0xDE] [0x00] [0x05] <mode:1> <mode:0> <power>
 - <mode:1> Boolean switch for TX power amplifier: 0 disabled, 1 enabled
 - <mode:2> Boolean switch for RX low power amplifier: 0 disabled, 1 enabled
 - <power> DUT power in dBm (hexadecimal)
- UPON RECEIPT: DUT will set mode and power on the DUT

GET_POWER

- COMMAND ID: 0x06
- DIRECTION: CMD->DUT
- PAYLOAD: [0xDE] [0xDE] [0x00] [0x06]
- UPON RECEIPT: DUT will send a GET_POWER_RESPONSE

GET_POWER_RESPONSE

- COMMAND ID: 0x07
- DIRECTION: DUT->CMD
- PAYLOAD: [0xDE] [0xDE] [0x00] [0x07] <power>
- UPON RECEIPT: CMD will indicate the GET_POWER_RESPONSE received
 - mode]0x%2x[power] %x

STREAM

- COMMAND ID: 0x09
- DIRECTION: CMD->DUT
- PAYLOAD: [0xDE] [0xDE] [0x00] [0x09] < duration(ms):1> < duration(ms):0>
- UPON RECEIPT: DUT will start a modulated waveform stream and then stop stream at end of duration. This provides the capability to pulse the modulated waveform on and off for testing.

START_RX_TEST

- COMMAND ID: 0x0A
- DIRECTION: CMD->DUT
- PAYLOAD: [0xDE] [0xDE] [0x00] [0x0A]
- UPON RECEIPT: DUT will clear totalPackets, protocolPackets, totalLQI, and totalRSSIMagnitude counters and begin incrementing statistics

END_RX_TEST

- COMMAND ID: 0x0B
- DIRECTION: CMD->DUT
- PAYLOAD: [0xDE] [0xDE] [0x00] [0x0B]
- UPON RECEIPT: DUT will stop incrementing statistics and send a REPORT

REPORT

- COMMAND ID: 0xC
- DIRECTION: DUT->CMD
- PAYLOAD: [0xDE] [0xDE] [0x00] [0xC] <totalPackets:3>
<totalPackets:2> <totalPackets:1> <totalPackets:0>
<protocolPackets:3> < protocolPackets:2> < protocolPackets:1> <
protocolPackets:0> <totalLqi:3> < totalLqi:2> < totalLqi:1> <
totalLqi:0> <totalRssiMagnitude:3> < totalRssiMagnitude:2> <
totalRssiMagnitude:1> < totalRssiMagnitude:0>
- UPON RECEIPT: CMD will print statistics
 - o"[total]0x%x%x%x%x [protocol]0x%x%x%x%x
[totalLqi]0x%x%x%x%x [totalRssiMgnitude]0x%x%x%x%x"
- Currently:
 - <totalPackets> field is ignored
 - Assumes no RSSI values measured that are greater than zero dBm
 - <totalRssiMagnitude> is the sum of inverted (i.e., absolute value) RSSI values (e.g., measured value of -87 dBm will be reported as <totalRssiMagnitude> = "87")
 - <totalLqi> field is ignored

REBOOT

- COMMAND ID: 0x0D
- DIRECTION: CMD->DUT
- PAYLOAD: [0xDE] [0xDE] [0x00] [0x0D]
- UPON RECEIPT: DUT will reboot

GET_REBOOT_BYTE_RESPONSE

- COMMAND ID: 0x10
- DIRECTION: DUT->CMD
- PAYLOAD: [0xDE] [0xDE] [0x00] [0x0x10] <rebootByte>
- UPON RECEIPT: CMD will print indication of ACK receive
 - "[rebootByte]0x%x"

GET_HARDWARE_VERSION

- COMMAND ID: 0x11
- DIRECTION: CMD->DUT
- PAYLOAD: [0xDE] [0xDE] [0x00] [0x0x11]
- UPON RECEIPT: DUT will send a GET_HARDWARE_VERSION_RESPONSE

GET_HARDWARE_VERSION_RESPONSE

- COMMAND ID: 0x12
- DIRECTION: DUT->CMD
- PAYLOAD: [0xDE] [0xDE] [0x00] [0x0x12] <hardware version>
 - <hardware version> is the same Unsigned 8-bit integer (HWVersion) defined in the ZCL
- UPON RECEIPT: CMD will print indication of GET_HARDWARE_VERSION_RESPONSE it received
 - [hardware version] char %x

GET_SOFTWARE_VERSION

- COMMAND ID: 0x13
- DIRECTION: CMD->DUT
- PAYLOAD: [0xDE] [0xDE] [0x00] [0x0x13]
- UPON RECEIPT: DUT will send a GET_SOFTWARE_VERSION_RESPONSE

GET_SOFTWARE_VERSION_RESPONSE

- COMMAND ID: 0x14
- DIRECTION: DUT->CMD
- PAYLOAD: [0xDE] [0xDE] [0x00] [0x0x14] <software version>
 - <software version> is an Unsigned 8-bit integer indicating the version of the test firmware
- UPON RECEIPT: CMD will print indication of GET_SOFTWARE_VERSION_RESPONSE it received
 - [software version] char %x

CMD Application Commands

- All commands to be issued on the CMD node - these will be called via test script
- The CMD node is the target for 'l'xxx (local) commands
- The DUT node is the target for 'r'xxx (remote) commands
- General commands are convenient abstractions for syncing the CMD and the DUT nodes
- The sole purpose of the reboot Byte is acting as a way in which a reboot can be verified - the reboot Byte variable will be reverted to the default after being changed
- The "custom find" command is a mechanism in which a "lost" DUT can be forced to a particular channel
- Command will accept both decimal and noted hex argument

"custom rping"

- CMD will send PING
- If PING is received, DUT will send ACK

- CMD will print "ACK" is ACK received before timeout
 - CMD will print "NO ACK" is timeout reached before ACK received
- "custom lpingtimeout <timeout(ms):1> <timeout(ms):0>"
- Will change ping timeout on CMD (default is 500 ms)
- "custom set channel <channel:3> <channel:2> <channel:1> <channel:0>"
- CMD will send SET_CHANNEL to DUT
 - CMD will set channel
 - CMD will send PING to DUT (refer to "custom rping")
- "custom lsetchannel <channel:3> <channel:2> <channel:1> <channel:0>"
- CMD will set channel
- "custom rsetchannel <channel>"
- CMD will send SET_CHANNEL to DUT
- "custom lgetchannel"
- CMD will return channel
- "custom lsetpower <mode:1> <mode:0> <power>"
- CMD will set power
- "custom rsetpower <mode:1> <mode:0> <power>" (for future revision/release)
- CMD will send SET_POWER to DUT
- "custom lgetpower"
- CMD will return power
- "custom rgetpower"
- CMD will send GET_POWER to DUT
 - DUT will send GET_POWER_RESPONSE to CMD
- "custom rstream <duration(ms):1> <duration(ms):0>"
- CMD will send STREAM to DUT
 - DUT will transmit a modulated waveform for the duration specified
- "custom rstart"
- CMD will send START_RX_TEST to DUT
 - DUT will clear totalPackets, protocolPackets, totalLQI, and totalRSSIMagnitude counters
 - DUT will begin incrementing statistics
- "custom rend"
- CMD will send END_RX_TEST to DUT
 - DUT will stop incrementing statistics
 - DUT will send REPORT to CMD
- "custom reboot"
- CMD will send REBOOT to DUT

- CMD will reboot

"custom lreboot"

- CMD will reboot

"custom rreboot"

- CMD will send REBOOT to DUT

"custom find <channel>

- CMD will send SET_CHANNEL to DUT on all channels
- CMD will set channel to channel passed to the function
- CMD will send PING to DUT (refer to "custom rping")

"custom rhardwareversion"

- CMD will send GET_HARDWARE_VERSION to DUT
- DUT will send GET_HARDWARE_VERSION_RESPONSE to CMD

"custom rsoftwareversion"

- CMD will send GET_SOFTWARE_VERSION to DUT
- DUT will send GET_SOFTWARE_VERSION_RESPONSE to CMD

FIGURE V-3 ZIGBEE TOTAL RADIATED POWER TEST CASE COMMAND FLOW

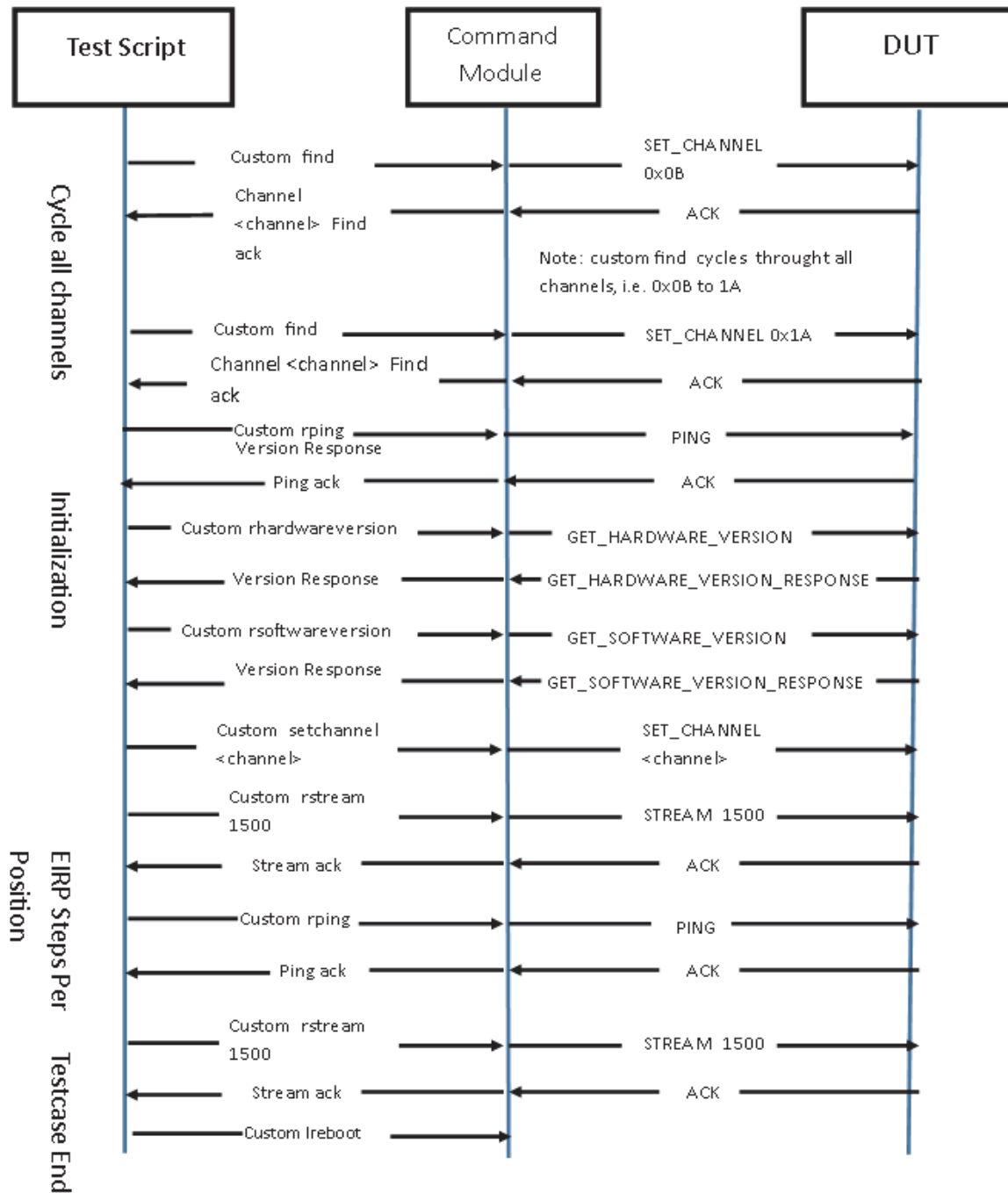
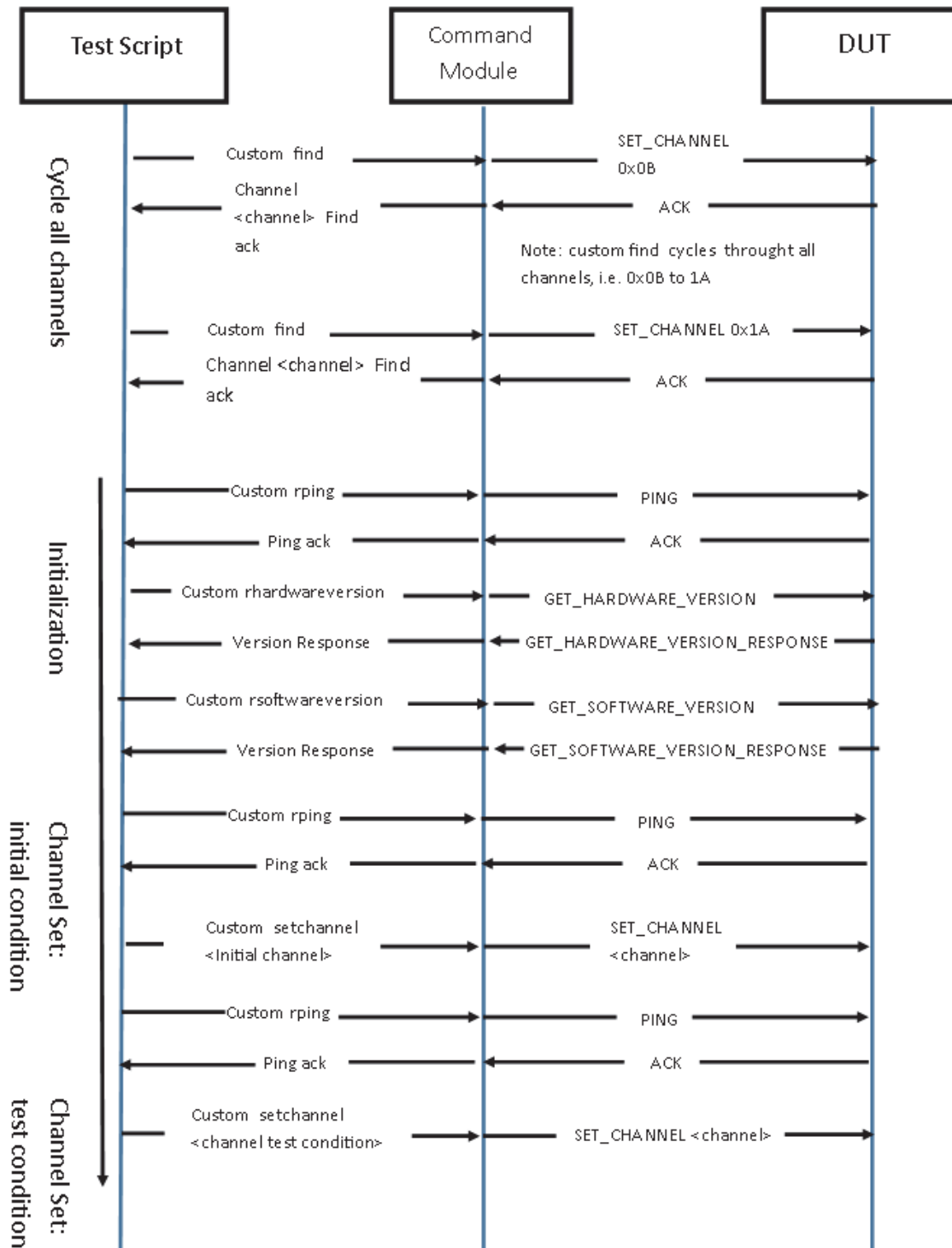

FIGURE V-4 ZIGBEE TOTAL ISOTROPIC SENSITIVITY TEST CASE COMMAND FLOW



Appendix W List of Cited References (Informative)

The documents listed in this appendix are cited throughout the document and denoted by numbers in square brackets, for example, [3]. These documents are separate from the Applicable Documents listed in [Section 1.3](#).

TABLE W-1 LIST OF CITED REFERENCES

Reference Number	Document
[1]	Foegelle, M.D., <i>Antenna Pattern Measurement: Theory and Equations</i> , Compliance Engineering, 2002 Annual Reference Guide, Vol. XIX, No. 3, pp. 34-43.
[2]	This section was adapted directly from IEEE Std 1528-2003 TM . Refer to this document for additional clarification.
[3]	Oflı E., Chavannes N., and Kuster N., <i>The Uncertainties and Repeatability Limitations of Transmitter and Receiver Performance Assessments Posed by Head Phantoms</i> , Proc. IEEE International Workshop on Antenna Technology (IWAT06), pp. 349-352, New York, 2006.
[4]	Gabriel, C., "Tissue Equivalent Material for Hand Phantoms," <i>Physics in Medicine and Biology</i> , 52 (2007), pp. 4205 - 4210,
[5]	W.C. Jakes, Editor, <i>Microwave Mobile Communications</i> , John Wiley & Sons, 1974, Chapter 3.
[6]	This terminology is borrowed from T. Taga, <i>Analysis for Mean Effective Gain of Mobile Antenna in Land Mobile Radio Environments</i> , IEEE Transactions on Vehicular Technology, Vol. 39, No. 2, May, 1990.
[7]	Stutzman & Thiele, <i>Antenna Theory and Design</i> , First Edition, John Wiley & Sons, 1981, pages 38 and 49.
[8]	See for example Cheney and Kincaid, <i>Numerical Mathematics and Computing</i> , Second Edition, Brooks/Cole Publishing, 1985, pp. 161 ff.
[9]	NIST, "Guidelines for evaluating and expressing the uncertainty of NIST measurement results", Technical Note 1297 (TN 1297), United States Department of Commerce Technology Administration, National Institute of Standards and Technology, Gaithersburg, MD, 1994.
[10]	IEEE, 1528-2002 SCC34 Draft Standard: <i>Recommended Practice for Determining the Peak Spatial-Average Specific Absorption Rate (SAR) in the Human Body Due to Wireless Communications Devices: Experimental Techniques</i> , April 2002.
[11]	Li C-H., Oflı E., Chavannes N., and Kuster N., "The Effects of Hand Phantom on Mobile Phone Antenna OTA Performance", Proc. Second European Conference on Antennas and Propagation, EuCAP 2007, Edinburgh, UK, November 11 - 16, 2007.
[12]	NIS 81, "The Treatment of Uncertainty in EMC Measurements," Ed. 1, NAMAS Executive, National Physical Laboratory, Teddington, Middlesex, TW11 0LW, England, 1994.
[13]	Gregory, A.P., and Clarke, R.N., "Dielectric Metrology with Coaxial Sensors", Meas. Sci. Technol. 18 (2007), 1372 -1386.

TABLE W-1 LIST OF CITED REFERENCES

Reference Number	Document
[14]	Gabriel, C., Chan, T.Y.A, and Grant, E.H., "Admittance models for open ended coaxial probes and their place in dielectric spectroscopy", Physics in Medicine and Biology, 39 (1994), pp. 2183 - 2200.
[15]	"Optimized procedure for dielectric property characterization of moldable materials", Indexsar Ltd. Application Note AppNote 08005
[16]	"Basics of Measuring the Dielectric Properties of materials," Hewlett-Packard Company, Application Note 1217-1.
[17]	A. Toropainen, P. Vainikainen, A Drossos, <i>Method for accurate measurement of complex permittivity of tissue equivalent liquids</i> , Electronic Letters 36 (1), 2000, pp32-34.
[18]	NPL National Physical Laboratory, "A Guide to the characterization of dielectric materials at RF and microwave frequencies", ISBN 0 904457 38 9 (2003), pp. 10ff, 107ff.
[19]	IEEE P1528.1™/D1.0 Draft Recommended Practice for Determining the Peak Spatial-Average Specific Absorption Rate (SAR) in the Human Body from Wireless Communications Devices, 30 MHz - 6 GHz: General Requirements for using the Finite Difference Time Domain (FDTD) Method for SAR Calculations
[20]	IEEE P1528.4™/D1.0 Draft Recommended Practice for Determining the Peak Spatial Average Specific Absorption Rate (SAR) in the Human Body from Wireless Communications Devices, 30 MHz - 6 GHz: Requirements for Using the Finite-Element Method for SAR Calculations, specifically involving Vehicle-Mounted Antennas and Personal Wireless Devices
[21]	Beard, B.B, et al., "Comparisons of Computed Mobile Phone Induced SAR in the SAM Phantom to That in Anatomically Correct Models of the Human Head", IEEE Transactions On Electromagnetic Compatibility, Vol. 48, No. 2, p. 397 - 407, May 2006.
[22]	IEEE P1528.3™/D2.0 Draft Recommended Practice for Determining the Peak Spatial-Average Specific Absorption Rate (SAR) in the Human Body from Wireless Communications Devices, 30 MHz - 6 GHz: General Requirements for using the Finite Difference Time Domain (FDTD) Modeling of Mobile Phones/Personal Wireless Devices
[23]	Huff, J.D, et al., "USING SPHERICAL NEAR-FIELD TRANSFORMS TO DETERMINE THE EFFECTS OF RANGE LENGTH ON THE MEASUREMENT OF TOTAL RADIATED POWER", 34th Proceedings of the Antenna Measurement Techniques Association (AMTA-2012), Bellevue, WA, October 2012.

Appendix X Change History

Date	Version	Description
October 2001	1.0	<ul style="list-style-type: none"> • First Revision
December 2001	1.1	<ul style="list-style-type: none"> • Modified measurement distance • Added definition for minimum measurement distance • Changed sleeve dipole to Calibrated Substitution Antenna • Modified simulated head reference information and head fluid recipe
March 2003	2.0	<ul style="list-style-type: none"> • Added Measurement Uncertainty section • Added appendix on calculating uncertainty values • Identified individual measurement procedures for Conical Cut and Great Circle Cut • Modified Test Procedure - Radiated Power for CDMA • Modified Test Procedure - Receiver Performance for CDMA • Modified Signal Level Ripple Within Quiet Zone • Modified Test Site Characteristics & Quiet Zone Accuracy • Modified Power Measurement Considerations • Added detail to test report requirements • Added additional detail to SAM Head Phantom definition • Editorial revisions • Changed title to "Test Plan for Mobile Station Over the Air Performance"

Date	Version	Description
April 2005	2.1	<ul style="list-style-type: none"> • Updated requirements for EUT submission • Allowed alternative configuration of SAM head phantom centered on Phi axis of rotation • Defined maximum allowable phantom fluid bubble size • Corrected step 2 of the theta-axis ripple test • Replaced Substitution Part with Range Reference Measurement and expanded procedure • “Modified TRP test procedures <ul style="list-style-type: none"> - Standardized formatting of sub-sections - Added alternate test procedures for TRP where multiple protocols occupy the same band - Added GPRS and EGPRS test procedures - Adjusted initial settings in base station parameters tables - Added conducted power test procedures • Modified TIS test procedures <ul style="list-style-type: none"> - Standardized formatting of sub-sections - Modified GSM to match single-ended search of CDMA - Allowed higher FER normalized to 0.5% for CDMA - Added procedures for measuring relative sensitivity on intermediate channels - TDMA and AMPS TIS no longer required - Added alternate test procedures for TIS where multiple protocols occupy the same band - Added GPRS and EGPRS test procedures - Added conducted sensitivity test procedures • Replaced Random Uncertainty section with Miscellaneous Uncertainty • Added uncertainty terms for alternative test method and defined previously TBD terms • Defined use of base station simulators for power measurements • Updated Test Set-Up Configuration appendix • Modified summations for near-horizon terms to adequately represent a trapezoidal integration • Updated CDMA power measurement method. <p>Note: Empirical data indicate that measurements made under the previous method would be ~ .38 dB ±.32 dB lower than the current method for cellular band and ~ .60 dB ±.18 dB lower than the current method for PCS band.</p> <ul style="list-style-type: none"> • Harmonized with CTIA Certification Program Management Document

Date	Version	Description
November 2006	2.2	<ul style="list-style-type: none"> • Updated Applicable Documents • Clarified wording on the ripple test requirements • Added recommendation to perform TRP/TIS concurrently or allow EUT warm-up time <p>Modified TRP test procedures</p> <ul style="list-style-type: none"> - TDMA TRP no longer required - Added UMTS TRP test procedures - Added CDMA 1xEV-DO Data TRP test procedures - Added CDMA 1xRTT Data TRP test procedures <ul style="list-style-type: none"> - Modified the allowable service options for CDMA testing - Updated alternate test procedure for TRP <ul style="list-style-type: none"> • Modified TIS test procedures - Added CDMA 1xEV-DO Data TIS test procedures - Added CDMA 1xRTT Data TIS test procedures - Added UMTS TIS test procedures - Added alternate test procedure for GSM TIS using less than maximum TX power - Updated alternate test procedure for TIS - Clarified requirements for target digital error rates for each protocol • Added pass/fail criteria for AMPS and CDMA free-space testing • Added Device Power Class to Summation Test Report • Added Intermediate Channel Relative Sensitivity Report • Increased the allowance for TIS uncertainty to ± 2.25 dB • Expanded SAM head-reference information • Updated Power Measurement Considerations - Added detail for the use of power meters - Made the RMS detector the default detector for spectrum analyzers and specified required sampling rates - Added EGPRS (8-PSK) power measurement - Added WCDMA power measurement • Replaced EUT modulation detection uncertainty contribution with sensitivity search step size
January 2008	2.2.1	<ul style="list-style-type: none"> • Updated GPRS and EGPRS test procedures • Corrected UMTS Maximum TIS Requirements table • Added pass/fail matrix to Summation Test Report table
December 2008	2.2.2	<ul style="list-style-type: none"> • Updated section 1.6 • Replaced Table 5-7, Table 5-30, Table 5-34. • Replaced Table 6-1, Table 6-11, Table 6.12 • Replaced all tables in Appendix B introduction (before section B.1)

Date	Version	Description
April 2009	3.0 (Not Published)	<ul style="list-style-type: none"> • Section 1 modified slightly for hand phantom, and numerous references added. • Section 2 simplified, modified to add hand phantom with head phantom and hand phantom only test configurations, add a section added for the Theta Dependent Phi Step Size Optimization. • Section 3 modified to address new frequency bands, new minimum range distance requirements, references to head and hand phantoms, and notebook sized devices. • Section 4 modified to support new frequency bands. • Section 5 modified to address new frequency bands, hand and head+hand testing, and removal of TDMA and AMPS. • Section 6 modified to address new frequency bands, hand and head+hand testing, removal of TDMA and AMPS, addition of receive diversity, addition of GPS, addition of MediaFLO, and TIS testing using RSS. • Section 7 heavily updated to address hand phantoms, new frequency bands, use of RSS methods, special considerations for notebooks, and updated expanded uncertainty limits. • Appendix A heavily modified to include information regarding positioning of devices in the hand phantoms, and the devices with the hand phantoms against the head phantom. • Appendix B modified to include new reporting tables, to address Theta Dependent Phi Optimization, to address UHIS and PIGS, and identification of hand phantoms. • Appendix C heavily modified to include definition of hand phantoms, reference information on hands and other requirements for hand phantoms. • Appendix D modified to remove TDMA and AMPS. • Appendix E modified to correct some technical issues with TIS and TRP definitions, and to address the use of RSS-based methods for TIS. • Appendix G heavily modified all areas of measurement uncertainty. Updated subsections for measurement uncertainty due to hand and head phantoms, and dielectric parameters. New subsections added to address the effect of theta dependent phi optimization on TIS, linearization of RSS measurements, RSS Data from EUT, Reporting Mechanism for RSS data from EUT, Special Considerations for Notebook Computers, Uncertainty due to Difference in Gain over Different Channel Bandwidths, and EUT Positioning/Repositioning. • Appendix H added to describe tissue equivalent dielectric property measurements. • Appendix I added to describe how to use simulations tools to assess measurement uncertainty. • Appendix K added to integrate specific intermediate channels lists. • Appendix L added to address notebook computer issues. • Appendix M added to list all cited references.

Date	Version	Description
January 2011	3.1	<ul style="list-style-type: none"> • Section 1: No changes • Section 2: No changes. • Section 3: Clarified discrepancies in notebook ripple test requirements, added Figure 3-8, Figure 3-9 and Figure 3-10 • Section 4: No changes. • Section 5: Moved text from Section 5.10.2 to Section 5.10. • Section 6: Added power classes to Table 6-9, editorial improvements to notes in Section 6.10 and Section 6.11, updated Table 6-22, editorial improvements to Section 6.13.3, added last two paragraphs for clarity. • Section 7: Updated Table 7-2 and Table 7-4, updated expanded measurement uncertainty in Table 7-8. • Appendix A: Require all fixtures and tools to use CTIA CAD files, updated A.1.3 hand phantom selection process, updated EUT alignment procedure and setup tolerance in A.1.4, added Figure A-13. • Appendix B: Corrected channel numbers in many tables. • Appendix C: Updated phantom dimension tolerances and head and hand dielectric tolerances, added notes stating solid tissue equivalents currently not allowed, editorial improvements to C.4.3, removed allowance to test with alternate hand phantoms. • Appendix D: No changes. • Appendix E: Replaced $\Delta(\theta)\Delta(\phi)$ with $\Delta(\phi)\Delta(\theta)$ in equations. • Appendix F: No changes. • Appendix G: Added the use of manufacturer data sheet in G.5, added hand phantom dielectric uncertainties, measurements and positioning in G.10, added note in G.17, editorial improvements in G.19. • Appendix H: Requires OCP method to be used in H, added note stating solid tissue equivalents currently not allowed. • Appendix I: No changes. • Appendix J: No changes • Appendix K: No changes. • Appendix L: Editorial improvements, allow custom free space notebook fixture in L.8, added angle tolerance to L.9. • Appendix M: No changes.

Date	Version	Description
November 2012	3.2	<ul style="list-style-type: none"> • Title: Changed the title to Test Plan for Wireless Device Over-the-Air Performance; Section 1: Removed references to CTIA Program Management Document (PMD); Added allowance to test multiple devices • Section 2: Removed head only testing requirements (throughout test plan) • Section 3: Added 3GPP bands 12, 17, 13, 14, 25 and removed MediaFLO • Section 4: Added 3GPP bands 12, 17, 13, 14, 25 and removed MediaFLO; Added allowance for Ripple Based Calibration; Added calibration correction for wideband channels • Section 5: Added Hand Left (HL), Beside Head and Hand Left (BHHL) and removed Beside Head (BHL and BHR); Added TRP criteria values for GSM, GPRS, EGPRS and UMTS; Added LTE TRP Test Procedure; Added CDMA Base Station Parameters for AWS-1 band • Section 6: Added Hand Left (HL), Beside Head and Hand Left (BHHL) and removed Beside Head (BHL and BHR); Changed Intermediate Channel sensitivity test method, criteria and test configurations; Added TIS criteria values for GSM, GPRS, EGPRS and UMTS; Added LTE TIS Test Procedures for with and without complex pattern data, added GPS for LTE devices • Section 7: Added MU calculations for ripple within quiet zone and wideband frequency flatness; Added MU calculations for mismatch terms; Changed total expanded uncertainty limit values • Appendix A: Added Hand Left (HL), Beside Head and Hand Left (BHHL) • Appendix B: Added Hand Left (HL), Beside Head and Hand Left (BHHL) and removed Beside Head (BHL and BHR); Added 3GPP bands 12, 17, 13, 14, 25 and removed MediaFLO; Added LTE TRP and TIS; Added test frequencies corresponding to test channels; Added RSS based data reporting • Appendix C: Added left hand phantoms • Appendix D: Added method of correcting RBW for spectrum analyzer NBW; Added LTE power measurement description • Appendix E: No changes • Appendix F: No changes • Appendix G: Improved mismatch measurement method; Added MU for use of inadequate measurement distance; Added 3GPP bands 12, 17, 13, 14, 25 and removed MediaFLO; Added MU contributor for use of wide bandwidths • Appendix H: No changes • Appendix I: No changes • Appendix J: No changes • Appendix K: Added 3GPP bands 12, 17, 13, 14 and 25 • Appendix L: Clarified notebook fixture allowances • Appendix M: New appendix adding optional GSM, UMTS and LTE bands • Appendix N: New appendix describing path loss errors induced by propagation delays • Appendix O: New appendix incorporating recommended use cases previously described in the CTIA PMD and PTCRB NAPRD0
March 2013	3.2.1	<ul style="list-style-type: none"> • Various editorial changes and minor corrections were made throughout the test plan. • Appendix O: Subsections O.7.2 to O.7.4 were added to O.7, Special Test Requirements.
August 2013	3.2.2	<ul style="list-style-type: none"> • Corrected Band 25 frequencies in Table K-7 • Added Appendix O.7.5 to fix CDMA 800 Intermediate Channels

Date	Version	Description
October 2013	3.3	<ul style="list-style-type: none"> • Section 1: No changes • Section 2: No changes • Section 3: Added bands 26 & 41. • Section 4: Added bands 26 & 41. • Section 5: Added bands 26 & 41. Added FS limits for CDMA 2100/1700. Removed requirement for GSM HR/HL testing. • Section 6: Added bands 26 & 41. Added FS limits for CDMA 2100/1700. Modified relative sensitivity measurement procedure to remove the single orientation allowance. Removed requirement for BHHR/BHHL testing for A-GPS w/LTE and LTE when voice is not supported in LTE. Removed requirement for GPRS, CDMA 1xRTT data and CDMA 1xEVDO ICD testing in some cases. Allowed use of A-GPS C/N₀ pattern obtained using one cellular mode and band with a different cellular mode and band if the GPS antenna is not dynamically tuned. Removed requirement for GSM HR/HL testing. • Section 7: No changes. • Appendix A: No changes. • Appendix B: Added bands 26 & 41 tables. Added FS limits for CDMA 2100/1700 table. Modified A-GPS for LTE pass/fail summary table. • Appendix C: No changes. • Appendix D: Added TDD mode to LTE power measurements. • Appendix E: No changes. • Appendix F: No changes. • Appendix G: Modified VSWR & Ripple Effect on Range Reference Measurement. Added bands 26 & 41. • Appendix H: No changes. • Appendix I: No changes. • Appendix J: No changes. • Appendix K: Modified Intermediate Channels for CDMA 800. Added bands 26 & 41. • Appendix L: No changes. • Appendix M: Added bands 38, 39, and 40. • Appendix N: No changes. • Appendix O: Removed requirement to non-primary mechanical modes at low and high channels. Added bands 26 & 41. Removed requirement for GSM hand-only testing. • Appendix P: Added Integrated Device Appendix (Normative)
July 2014	3.2.3	<ul style="list-style-type: none"> • Note: This revision was produced after the 3.3 version and exists separately from 3.3.1. • Modified relative sensitivity on intermediate channels procedure to clarify handling of secondary antennas. • Selection of closest reference channels for Band 4 updated in Table K-7 • Added waiver in Appendix O.8.2 to remove UE-based testing for A-GPS OTA for LTE. • Added exception in Appendix O.7.7 for head adjacent A-GPS OTA for LTE testing for devices that do not support VoIP. • Added Appendix O.8.3 to clarify OTA testing for devices containing multiple TX antennas

Date	Version	Description
September 2014	3.2.4	<ul style="list-style-type: none"> • Note: This revision was produced after the 3.3.1 version and exists separately from 3.3.2. • Changed recommended limit for GSM HL/HR from TBD to N/A since GSM HL/HR testing is not required • Clarified test applicability for LTE A-GPS OTA testing in Section 6.13.3 • Removed the waiver for LTE A-GPS OTA testing when using LPP as a Positioning Protocol in Appendix O.7.4
July 2014	3.3.1	<ul style="list-style-type: none"> • Modified relative sensitivity on intermediate channels procedure to clarify handling of secondary antennas. • Selection of closest reference channels for Band 4 updated in Table K-7. • Added waiver in Appendix O.8.2 to remove UE-based testing for A-GPS OTA for LTE. • Added note in Appendix O.7.7 that this special test requirement is no longer required since it is already covered in the test plan. • Added Appendix O.8.3 to clarify OTA testing for devices containing multiple TX antennas. • Added contact information in Appendix C.4 for parties interested in obtaining the hand phantom CAD files. • Clarified the reporting requirements for the primary antenna and associated receiver for diversity capable EUTs in Table B-85 to Table B-96. • Added Appendix O.8.4 which contains modifications to Appendix G.10.5 indicated by underlined text. • Removed note in Section 6.2.1 concerning the fact that there are no CDMA 2100/1700 pass/fail requirements since pass/fail requirements were added in v3.3.
September 2014	3.3.2	<ul style="list-style-type: none"> • Changed recommended limit for GSM HL/HR from TBD to N/A since GSM HL/HR testing is not required • Clarified test applicability for LTE A-GPS OTA testing in Section 6.13.3 • Removed the waiver for LTE A-GPS OTA testing when using LPP as a Positioning Protocol in Appendix O.7.4 • Clarified device type and quantity to be used for Band 41 MU assessment of Phone Positioning Uncertainty in Appendix O.8.4 • Removed steps 12 and 13 in Appendix O.7.9.1.
December 2014	3.4	<ul style="list-style-type: none"> • Changed LTE Band 7 from informative to normative. • Changed LTE Band 12 testing from 10 MHz BW to 5 MHz BW. • Added LTE Band 30 as a normative band. • Clarified that Note 3 in Appendix O.5 applies to tablets. • Clarified that A-GPS testing is performed with the device operating in normal operating state with regards to the use of cellular diversity antennas. • In Appendix O.8.4, expanded waiver to use fewer devices for the phone positioning uncertainty experimental evaluation to include LTE Band 7.
April 2015	3.4.1	<ul style="list-style-type: none"> • Changed Band 14 UL RB Allocation from 20 RBs to 15 RBs in Table K-7 • Changed Band 12 DL RB Allocation to 25 RBs in Table 6-18 • Modified Appendix O.1 through Appendix O.6 • Appendix O.7.9 updated, Appendix O.7.10 and Appendix O.7.11 added to clarify the number and type of phones required for assessing the head and hand phantoms fixturing uncertainty and the uncertainties of positioning the EUT in the hand and against the head phantoms
May 2015	3.4.2	<ul style="list-style-type: none"> • Appendix O.5: Updated to remove requirement for GPS OTA testing in free space. Updated guidelines for large or heavy integrated devices.

Date	Version	Description
June 2015	3.5	<ul style="list-style-type: none"> • Section 1: Added info for A-GNSS LTE device preparation info. Added antenna labelling requirements. Clarified manufacturer declaration requirements. Clarified requirements for manufacturer to supply instructions. • Section 2: No changes. • Section 3: Added 3GPP band 29 and changed GPS to GNSS minimum measurement distance and quiet zone test frequencies. • Section 4: Added 3GPP band 29 and GLONASS range reference measurement. Corrected 3GPP band 12 range reference frequencies. • Section 5: Added Section 5.12, LTE Two Downlink Carrier Aggregation (Single Uplink Carrier) and Section 5.13, OTA Testing of Devices Containing Multiple TX Antennas. • Section 6: Added explanation of Figure 6-1. Restructured Section 6.13 to allow for A-GNSS testing. Included A-GLONASS testing for LTE using SUPL 2.0. Removed the requirement to test UE-Based performance for A-GNSS OTA for LTE. Added Section 6.18, LTE Two Downlink Carrier Aggregation TIS/EIS (Single Uplink Carrier). Updated section to reflect new antenna labeling requirements. • Section 7: No changes. • Appendix A: Added CTIA contact information. • Appendix B: Added new tests and bands to test report requirements. Updated tables to reflect new antenna labelling requirements. • Appendix C: No changes. • Appendix D: Added Note 2 to Table D-1. • Appendix E: No changes. • Appendix F: No changes. • Appendix G: Added additional MU in Section G.10.2 for extended SAM phantom. Clarifications in Appendix G.10.5.1. Changed GPS to GNSS in Table G-6. Appendix G.10.1, G.10.4 and G.10.5 updated to clarify the number and type of phones required for assessing the uncertainties of positioning the EUT in the hand and against the head phantoms. • Appendix H: No changes. • Appendix I: No changes. • Appendix J: No changes. • Appendix K: No changes. • Appendix L: No changes. • Appendix M: Changed GPS to A-GNSS. • Appendix N: No changes. • Appendix O: Added implementation conformance statements for LTE 2 DL carrier aggregation (single uplink carrier). Removed Waiver of UE Based Testing for A-GPS OTA for LTE. OTA Test of Devices Containing Multiple TX Antennas and Modification to Phone Positioning Uncertainty now moved to normative sections. Added A-GNSS free space OTA test requirements for integrated devices. • Appendix P: Added Appendix P.7 Considerations for Externally-powered Devices. Added Appendix P.9 A-GNSS Testing for Integrated Devices. Added Appendix P.10.3 Positioning an Integrated Device with a Removable Antenna Connected Directly to the Device via an RF Transmission Line (Such as a Coaxial Cable) Less Than 20 cm in Length. • Appendix Q: No changes
July 2015	3.5.1	<ul style="list-style-type: none"> • Updated Table 6-17 to fix uplink RB allocations. • Updated reporting tables for A-GNSS ICD and Table K-7 to remove operating bands with only one reference channel.

Date	Version	Description
September 2015	3.5.2	<ul style="list-style-type: none">• Updated Table B-97 through Table B-117 SCC DL values with the values listed in Table 5-30.• Fixed equation numbering issue in Appendix B.• Deleted "This is the average of the associated ripple measurement, again in linear units" in Appendix G.8.1.• Added to USB Modem definition in Appendix O.2.

Date	Version	Description
June 2016	3.6	<ul style="list-style-type: none"> • Section 1: Updated and reordered documents in Section 1.3. Updated references to these documents throughout the test plan. • Section 2: No changes. • Section 3: No changes. • Section 4: No changes. • Section 5: Removed BHHR/BHHL test requirement for LTE CA TRP. Added Spiral Scan TRP Procedure for TRP. Allowed testing of LTE CA TRP using fewer component carriers as long as the antenna is tuned correctly. Added new channel combinations for LTE 2 DL CA. Added LTE 3 DL CA. Removed channel designations. Added test reductions for GSM/GPRS/EGPRS and CDMA/1xRTT/1xEV-DO for voice centric handsets. Clarified DL channel configurations for LTE TRP measurements. • Section 6: Removed BHHR/BHHL test requirement for LTE CA TIS. Updated sensitivity requirements for GPRS, EGPRS and WCDMA. Clarified test conditions for A-GNSS TIS. Allowed testing of LTE CA TIS using fewer component carriers as long as the antenna is tuned correctly. Added new channel combinations for LTE 2 DL CA. Added LTE 3 DL CA. Removed channel designations. Added test reductions for GSM/GPRS/EGPRS and CDMA/1xRTT/1xEV-DO for voice centric handsets. Added Control Plane A-GNSS for LTE. Combined Alternate TIS procedures into one section. • Section 7: No changes. • Appendix A: Added usage and positioning guidelines for wide grip hand phantom. • Appendix B: Updated reporting tables for devices using the wide grip hand phantoms. Removed BHHR/BHHL test cases for LTE CA TRP and TIS. Added reporting tables for new channel combinations for LTE 2 DL CA. Added reporting tables for LTE 3 DL CA. Updated reporting tables for Control Plane A-GNSS for LTE. Added dual-TX reporting tables. Reorganized Appendix B.3 • Appendix C: Added wide grip hand phantom definition. Added recommendation to new hand phantom manufacturers to contact CTIA. • Appendix D: Updated sampling time requirements for power meters. • Appendix E: No changes. • Appendix F: No changes. • Appendix G: No changes. • Appendix H: No changes. • Appendix I: No changes. • Appendix J: No changes. • Appendix K: No changes. • Appendix L: No changes. • Appendix M: No changes. • Appendix N: No changes. • Appendix O: Removed BHHR/BHHL OTA testing for LTE CA. ICS for LTE 2 DL CA updated and ICS for LTE 3 DL CA added. Added test reductions for GSM/GPRS/EGPRS and CDMA/1xRTT/1xEV-DO for voice centric handsets. Removed obsolete special test cases in Appendix O.8. • Appendix P: Updated reporting tables for Control Plane A-GNSS for LTE. Added Guidelines for the Attachment of Additional EUT Accessories (i.e., non-antenna accessories) • Appendix Q: No changes.

Date	Version	Description
October 2016	3.6.1	<ul style="list-style-type: none"> • Corrected some channels in Table 5-32. • Corrected several footnotes and the DL RB allocation for LTE CA_30A-12A in Table 6-22. • Changed LTE CA_4A-4A-2A to CA_4A-2A-4A in several tables. • Added missing tables and references associated with LTE 3 DL CA for CA_5A-4A-30A, CA_30A-4A-29A, CA_5A-29A-30A, and CA_30A-5A-29A. • Several tables in Appendix B were corrected for channels and frequencies. • Appendix O.8.2 added to clarify the use of relative measurement testing using different samples or chambers. • Appendix O.8.3 added to clarify the need for resets between measurements during A-GNSS sensitivity measurement.
May 2017	3.6.2	<ul style="list-style-type: none"> • Section 1: Clarified that samples representative of production units must be supplied. • Section 5: Clarified that p-Max shall not be signaled. • Section 6: Corrected locations of Note 4 in Table 6-24. Clarified that p-Max shall not be signaled. • Appendix B: Updated Table B-4 to include the antenna label for each use case. • Appendix O: Eliminated conducted performance testing of 2 DL and 3 DL LTE CA. Added LTE CA summary tables.
June 2017	3.7	<ul style="list-style-type: none"> • Section 1: Clarified OTA sample requirements. Added the allowance of different chambers and samples to be used for relative measurements. • Section 2: No changes. • Section 3: Added 3GPP band 66 and 70 minimum measurement distance and quiet zone test frequencies. Clarified the dipole and loop asymmetry requirement. • Section 4: Added 3GPP band 66 and 70 test frequencies for range reference measurements. • Section 5: Added 3GPP band 66 and 70. Eliminated conducted performance testing of 2 DL and 3DL LTE CA. Added new channel combinations for 2 DL and 3 DL LTE CA. Clarified that the manufacturer shall indicate which frequency bands and air interfaces support Tx antenna switching in Table B-2. Added section 5.15 for LTE Category M1 devices (informative). • Section 6: Added 3GPP band 66 and 70. Clarified the need for resets between measurements during A-GNSS sensitivity measurements regardless of operating mode. Added LTE A-GNSS sensitivity search requirements for 3GPP band 13 and 14 for devices that support transmitter antenna switching. Added LTE A-GNSS testing with the presence of SIB8 and SIB16 and the ICS logic for it. Eliminated conducted performance testing of 2 DL and 3DL LTE CA. Added new channel combinations for 2 DL and 3 DL LTE CA. Added section 6.18 OTA testing of devices with Rx antenna switching. Added section 6.19 for LTE Category M1 devices (informative). • Section 7: No changes. • Appendix A: No changes. • Appendix B: Moved reporting tables to the "OTA 3.7 Appendix B and P Tables" spreadsheet. • Appendix C: No Changes. • Appendix D: Reduced integration time with spectrum analyzers and other power measurement devices.

Date	Version	Description
June 2017	3.7	<ul style="list-style-type: none"> • Appendix E: No Changes. • Appendix F: No Changes. • Appendix G: Added 3GPP Band 66 and 70 to Table G-1. Simplified table G-6 by grouping frequencies. • Appendix H: No Changes. • Appendix I: No Changes. • Appendix J: No Changes. • Appendix K: Added intermediate channels for 3GPP Band 66. • Appendix L: No Changes. • Appendix M: No Changes. • Appendix N: No Changes. • Appendix O: In section O.3, Removed the need to test CDMA low and high channels when a failure is incurred during intermediate channel relative sensitivity tests when CDMA OTA testing is reduced. In Section O.8.1 added 3GPP Band 66. Removed the content in sections O.8.2 through O.8.5. • Appendix P: Added 3GPP band 66 and 70. Added LTE A-GNSS testing with the presence of SIB8 and SIB16. Moved reporting tables to the "OTA 3.7 Appendix B and P Tables" spreadsheet. • Appendix Q: Added appendix for Wrist-worn Devices (Informative). • Appendix R: Added appendix for Stand-Alone GNSS Testing (Informative). • Appendix S: Added appendix for how LTE CA OTA test channels were selected (informative). • Appendix T: No Changes.
February 2018	3.7.1	<ul style="list-style-type: none"> • Corrections made to Table 5-30, Table 5-32, Table 6-22 and Table 6-24. • Clarified that Table B-4 and P-1 are not to be used for reporting LTE CA test results. • Minor editorial text changes made. • Added waiver in Appendix O.8.6 to not require LTE A-GLONASS OTA Testing when using SIB8 or SIB16. • Sections 5.15 and 6.19 for Cat-M1 testing were removed.

Date	Version	Description
September 2018	3.8	<ul style="list-style-type: none"> • Entire Document: Globally changed references to “Appendix B and P Tables” to “Appendix B Tables” • Section 1: Section 1.6 updated to reflect changes for C-TIS, wrist-worn devices and LTE CA testing. • Section 3: Updated to incorporate changes needed for MBS. • Section 4: Updated to incorporate changes needed for MBS. • Section 5: Updated to reflect addition of wrist-worn testing. Updated to remove conducted testing for all cellular testing. Updated 5.8.1 to require transmission of the IE p-max for TRP testing of Power Class 1 devices. In Section 5.11.1, additional clarification provided on when single point offset tests can be used. Added TRP for Low Duty Cycle IoT Devices in Section 5.11.4. In Section 5.12, added new CA combination: CA_70C. Updated Section 5.15 to make LTE Cat-M1 normative and updated the LTE Cat-M1 TRP test measurements table. Updated to reflect addition of wrist-worn testing. • Section 6: Updated to remove conducted testing for all cellular testing. Updated to incorporate the measurement of C-TIS (Combined TIS). Replaced TIS with C-TIS. Removed references to the terms “branch power difference” and “primary and secondary receive antennas”. In Section 6.8, removed “Complex Pattern Measurement” for LTE. Removed 6.11 “CDMA with Receive Diversity” and 6.12 “UMTS Two-Branch Receive Diversity”. Section 6.13 updated to incorporate limits for integrated devices. Updated 6.13.5.4.2 and 6.13.5.4.3 to modify the A-GNSS sensitivity test conditions for LTE Band 14. In Section 6.15.1, additional clarification provided on when single point offset tests can be used. Updates made to Section 6.15.4 for MBS and the use of code phase RMS error indicators. Added TIS and Intermediate Channel Test Methodology for Low Duty Cycle IoT Devices (6.15.5). In Section 6.16, added new CA combination: CA_70C. Added Section 6.18 for MBS OTA Test Procedures. Section 6.19 updated to reflect use of C-TIS. Updated Section 6.20 to make LTE Cat-M1 normative and updated the LTE Cat-M1 TIS test measurements table. Added Section 6.21 for Downlink LTE LAA as Informative. • Section 7: MU for wrist-worn device tested added. • Appendix B: Updated references to Tables in “Appendix B Tables” in Appendix B.1 and Appendix B.2. Added Section B.7 to add photograph and identification requirements for the forearm phantom. • Appendix G: Section G.24 added to address MU for wrist-worn device testing. • Appendix I: Updated to reflect the use of simulation for evaluating forearm MU. • Appendix O: Updates to Appendices O.3 and O.4 on the applicability of BHHL, BHRH, HL, and HR testing (i.e. reductions in phantom testing). Appendix O.6 added to define wrist-worn test conditions. Appendix O.8 updated for CA and added LAA (as informative). CA testing defined according to the Operator CA Priority Lists. Added Appendix O.9 to define LTE Cat-M1 applicability. Appendix O.10 updated to remove conducted testing and to remove temporary requirement for LTE CA Summary Tables. • Appendix P: Test reports removed from this section and integrated into “OTA 3.8.x Appendix B tables”. A-GNSS test criteria removed from this section and integrated into Section 6.13.6.

Date	Version	Description
September 2018	3.8	<ul style="list-style-type: none"> • Appendix Q: Wrist-Worn Device Testing moved from Informative to Normative. Additional guidance on testing of wristbands and housing material provided. Appendix Q.4 modified to reduce testing to a single arm orientation (WL or WR) and to specify test requirements for A-GNSS. Appendix Q.7 removed as OTA limits for wrist-worn devices were integrated into Sections 5 and 6. Appendix Q.8 removed as reporting tables were integrated into "OTA 3.8.x Appendix B tables". • Appendix T: Bluetooth OTA test methodology added as Informative. • Appendix B Tables: Tables updated for C-TIS. Tables from Appendix P integrated. Tables for wrist-worn device testing added or integrated into existing tables. MBS Tables added. Tables added in the 2 DL CA Tables section for LTE CA_70A. Tables for LTE Cat-M1 added. A-GNSS reporting tables updated to include additional test cases for LTE 14.
October 2018	3.8.1	<ul style="list-style-type: none"> • Updated Acknowledgements page.
April 2019	3.8.2	<ul style="list-style-type: none"> • Minor editorial text changes made. • Corrected references in Table 7-2 and Table 7-4. • Removed references to ICS for CA testing. • Updated Table G-7 to correctly identify the 12 reference points for dielectric measurement on the forearm phantom. • Added clarification in Section 6.15.4 concerning usage of RSS based methods. • Appendix Q and Section 1.6 updated to clarify that wrist-worn testing shall be performed in one wrist-worn orientation. • Section 6: Removed some references to individual receiver TIS tests and clarified that C-TIS will be used. • Clarified references to Bluetooth SIG test cases in Appendix T. • Removed incorrect reference to wrist-worn testing for MBS in Section 6.18.6. • Clarified LTE Cat-M1 power measurement integration bandwidth for TIS in Section 6.20 and Appendix B tables. • Corrected GSM 1900 TIS limits and CDMA 1xEV-DO TIS limits. • Equation G.36 corrected. • In Table 6-24 and Table 6-26, corrected RB start and RB allocations for all 2A-2A related CA combinations. • In Appendix B tables, corrected LTE 70 to use 15 MHz channel bandwidth instead of 10 MHz channel bandwidth. • Added Appendix O.10.7 to clarify LTE Cat-M1 power measurements.

Date	Version	Description
November 2019	3.9	<ul style="list-style-type: none"> • Section 1: Section 1.3, updated to include updated references to 3GPP TS 38.508-1 and 3GPP TS 38.521-1. • Section 3: Section 3.1, updated Table 3-1 and Table 3-2 to incorporate Band 71, Band 46 and Band 48. Section 3.3, updated Table 3-3 to include Band 71, Band 46, Band 48. • Section 4: Section 4.3, updated Table 4-1 to include Band 71, Band 46, Band 48 and corrected Band 13 frequencies. Section 4.4.3, updated Table 4-2 to include Band 71, Band 46, Band 48, corrected Band 13 frequencies. • Section 5: Section 5.8, updated Table 5-20 and Table 5-21 to include Band 48 and 71. defined the acronym "IE" as "Information Element" in Section 5.8.1. Section 5.12.1, updated Table 5-30 and Table 5-31 to include: CA_2A-48A; CA_5A-48A; CA_13A-48A; CA_25A-25A; CA_48A-2A; CA_48A-5A; CA_48A-13A; CA_48A-66A; CA_66A-48A. Section 5.13.1, updated Table 5-32 and Table 5-33 to include: CA_2A-2A-4A; CA_2A-5A-48A; CA_2A-13A-48A; CA_2A-48A-66A; CA_5A-2A-48A; CA_5A-48A-66A; CA_13A-2A-48A; CA_13A-48A-66A; CA_25A-41C; CA_30A-2A-5A; CA_48A-2A-5A; CA_48A-2A-13A; CA_48A-5A-66A; CA_48A-13A-66A; CA_66A-2A-48A; CA_66A-5A-48A; CA_66A-13A-48A. Section 5.15, updated Table 5-34 and Table 5-35 to include Band 71. Section 5.16, Added NB-IoT including Table 5-36 and Table 5-37. Section 5.17, Added NR FR1 (Informative) including Table 5-38. • Section 6: Section 6.8.1, updated Table 6-6 to include Band 48 and Band 71. Section 6.8.2, First paragraph of 6.8.2 was modified to include "<i>Full TIS measurements may be substituted for relative sensitivity measurements</i>". Section 6.8.3, updated Table 6-8 to include Band 48 and Band 71. Section 6.9.1, the first sentence of the first paragraph of 6.9.1 was modified to read "<i>Relative sensitivity measurements or fully measured TIS shall be repeated per channel on a specified list of intermediate channels as shown in Appendix K.1</i>". Section 6.10.1, the first sentence of the ninth paragraph of 6.10.1 was modified to read: "<i>Relative sensitivity measurements or fully measured TIS shall be repeated per channel on a specified list of intermediate channels as shown in Appendix K.1</i>". Section 6.13, updated Table 6-15 to include Band 48 and Band 71, changed GPS references to GPS L1, added LTE Category M1 A-GNSS Testing, updated Table 6-19, Table 6-20, Table 6-21. Table 6-22, Table 6-23 and Table 6-24 to include Band 48 and Band 71. Section 6.15, changed GPS references to GPS L1. Section 6.15.4.1, changed the last sentence of the first paragraph to read "<i>If the RSS measurement for a particular polarization or point is below the dynamic range of the measurement capability or cannot be obtained, the data point shall be recorded with a value that is at least 20 dB below the lowest RSS measurement</i>". Section 6.16, updated Table 6-25 and Table 6-26 to include: CA_2A-48A; CA_5A-48A; CA_13A-48A; CA_25A-25A; CA_48A-2A; CA_48A-5A; CA_48A-13A; CA_48A-66A; CA_66A-48A. Section 6.17, updated Table 6-27 and Table 6-28 to include: CA_2A-2A-4A; CA_2A-5A-48A; CA_2A-13A-48A; CA_2A-48A-66A; CA_5A-2A-48A; CA_5A-48A-66A; CA_13A-2A-48A; CA_13A-48A-66A; CA_25A-41C; CA_48A-2A-5A; CA_48A-2A-13A; CA_48A-5A-66A; CA_48A-13A-66A; CA_66A-2A-48A; CA_66A-5A-48A; CA_66A-13A-48A. Section 6.18.6, updated Table 6-30 to include Band 48 Band 71. Section 6.20, updated Table 6-31 and Table 6-32 to include Band 71. Updated text in Section 6.20.2 ("Criteria"). Section 6.21, corrected table references in the fourth paragraph of 6.21.1. Added CA_25A-46A to Table 6-33. Section 6.21 changed to normative. Various updates made to text in "Full Band TIS Test" and "LAA Un-Licensed Degradation (LUD) Test. Added Table 6-35 and Table 6-36. Added Section 6.22 ("LTE Category NB-IoT") This included addition of Sections 6.22.1, 6.22.2, as well as Table 6-37 and Table 6-38. Added Section 6.23 "New Radio (NR) Frequency Range 1 (FR1) (Informative)" This included addition of Sections 6.23.1, 6.23.2 and 6.23.2, as well as Table 6-39.

Date	Version	Description
November 2019	3.9	<ul style="list-style-type: none"> • Section 7: Section 7.5, Added last paragraph of Section 7.5 and added Table 7-8 to include 3-6 GHz range. • Appendix B: Appendix B Tables updated to reflect: Added Band 71, Band 46 and Band 48. Added the following 2 DL CA combinations: CA_2A-48A; CA_5A-48A; CA_13A-48A; CA_25A-25A; CA_48A-2A; CA_48A-5A; CA_48A-13A; CA_48A-66A; and CA_66A-48A. Added the following 3 DL CA combinations: CA_2A-2A-4A; CA_2A-5A-48A; CA_2A-13A-48A; CA_2A-48A-66A; CA_5A-2A-48A; CA_5A-48A-66A; CA_13A-2A-48A; CA_13A-48A-66A; CA_25A-41C; CA_30A-2A-5A; CA_48A-2A-5A; CA_48A-2A-13A; CA_48A-5A-66A; CA_48A-13A-66A; CA_66A-2A-48A; CA_66A-5A-48A; and CA_66A-13A-48A. Added NB-IoT testing. Added LTE Cat-M1 AGNSS testing. Added LAA testing as normative. <p>The following tables were added or changed: Table B-7, Table B-8, Table B-9, Table B-10, Table B-11, Table B-12, Table B-13, Table B-17, Table B-18, Table B-19, Table B-20, Table B-22, Table B-23, Table B-24, Table B-25, Table B-26, Table B-27, Table B-28, Table B-29, Table B-30, Table B-31, Table B-32, Table B-33, Table B-88, Table B-103, Table B-104, Table B-119, Table B-120, Table B-135, various tables for the new 2 DL CA combinations between Table B-136 and Table B-400, various tables for the new 3 DL CA combinations between Table B-401 and Table B-935, new tables for LTE Cat-M1 from Table B-936 to Table B-953, new tables for LAA from Table B-954 to Table B-982, new tables for LTE Cat-NB1 from Table B-983 to Table B-1004, Table B-1009, Table B-1010, Table B-1011, Table B-1012, Table B-1013, Table B-1014 and Table B-1015.</p> <ul style="list-style-type: none"> • Appendix C: Appendix C.2 and C.4, updated third paragraph of C.2.2 and second paragraph of C.4.1 to read: <i>“Dielectric materials which only comply with the requirements over a portion of the 300 MHz to 6 GHz maybe used but only for tests where the band/protocol being measured is within the frequency band of compliance.”</i> • Appendix D: Appendix D.8, added missing paragraph related to minimum resolution bandwidth for broadband power measurements. Appendix D.9, updated D.10 to include a 1.4 MHz channel BW for Cat-M1. Updated D.11 to include a 200 kHz channel BW for Cat-NB1. Appendix D.10, added LTE Category M1 broadband power measurement. Added Table D-2. Added LTE Category NB1 (NB-IoT) broadband power measurement in D.11. Added NR FR1 (informative) broadband power measurement in D.12, added Table D-3. • Appendix G: Appendix G.7.4, added Band 71, Band 46 and Band 48 to Table G-1. G.10.1, updated the bulleted frequency list in G.10.1 to include coverage for GPS L5 in the second bullet and the fourth paragraph as well as the footnote. G.10.5.1, updated the second and third paragraphs. G.19.1, updated table G-6 to include the frequency utilized by GPS L5 and extended the upper frequency to 6 GHz. • Appendix K: Appendix K.4, Updated Table K-7 to include Band 48 and Band 71. • Appendix O: Appendix O.2, updated to include the definition for an “Integration Component”, “Target Operator” and “USB Modem”. O.3, updated Table O-1, Notes 1 and 2. Removed O.9 because Category M1 OTA testing was moved to normative in this release. O.10.1, Updated Table O-5 to include Band 48 and Band 71. O.10.7, deleted <i>“Modifications to LTE Category M1 Power Measurements”</i>. • Appendix P: Updated the “Purpose” text in P.1. Changed the test requirements for P.4.1 (Free-Space Testing). Added the test requirements for P.4.2 (Body-Worn Testing). Added test requirements for P.12 (“Testing of Cellular Desense due to Simultaneous Operation of 802.11 Radios for Integrated Devices”). • Appendix Q: Appendix Q.4.1.3, Modified A-GNSS C/N₀ value from 10 dB below the lowest C/N₀ value to 20 dB below the lowest C/N₀ value.

Date	Version	Description
November 2019	3.9	<ul style="list-style-type: none"> • Appendix R: Updated the list of bearer interfaces in R.3.1 to remove WiFi, replaced by 802.11x. Updated GPS in Sections R.5, R.6 and R.7 to refer to GPS L1. • Appendix U: Added "Phantom Material Selection Based on Test Frequency" • Appendix V: Added "ZigBee (Informative)"
May 2020	3.9.1	<ul style="list-style-type: none"> • Section 5: Corrections to Table 5-21, Table 5-30. • Section 6: Corrections to Table 6-25, Table 6-27, Table 6-31, and Table 6-34. Sections 6.2.1, 6.4.1, 6.5.1, 6.6.1, 6.7.1, 6.8.2, 6.9.1, and 6.10.1 updated to clarify the pass criteria when full TIS measurements are performed on intermediate channels. Section 6.21.1, removed the statement that required the use of the up to 3 GHz hand phantoms as it was in conflict with Appendix U. • Appendix B: Corrections to "OTA 3.9.x Appendix B Tables" for Tables B-257 through B-266 and Tables B-331, B-376, B-377, B-392, B-393, B-656, B-658, B-666, B-715, B-736, B-781, B-788, B-789, B-839, B-842, B-845, B-846, B-848, B-849, B-851, B-852, B-866, B-867, B-868, B-881, B-882, B-883, B-902, B-903, and B-904. One erroneous table was removed and tables were renumbered. • Appendix G: Clarified language in Appendix G.10.5.2. Clarified language in Appendix G.24.2 and updated Figure G-9. Clarified language in Appendix G.24.2 and updated Figure G-9. • Appendix O: Added reference to <https://testplans.ctia.org/> to Appendix O.8. Updated test applicability for LTE Cat-M1 and LTE Cat-NB1 in Appendix O.9. Appendix O.10.1 updated to clarify reporting requirements when the optional full TIS method is used for intermediate channels. Appendix O.10.8 added to update sensitivity factors for numerical evaluation of phone positioning uncertainty for 3000 - 6000 MHz range.
April 2021	3.9.2	<ul style="list-style-type: none"> • Section 4: Corrected editorial errors in test frequencies for Band 71 and Band 13 in Table 4-1. • Section 5: Corrections to Sections 5.16.1 and 5.16.2 to fix incorrect reference measurement channel reference and align criteria section with Appendix B tables. Corrected 3GPP reference for maximum output power test in Section 5.17.1. • Section 6: Corrections to Sections 6.22.1 and 6.22.2 to fix incorrect reference measurement channel reference and align criteria section with Appendix B tables. Editorial correction to Section 6.21 to remove statement to utilize hand phantoms up to 3 GHz for LAA. • Appendix B Tables: Various corrections made to Table B-7, Table B-8, Table B-9 and Table B-10. • Appendix O: Appendix O.10.9 added to provide dipole symmetry allowances for ripple testing.