



# Test Plan for Wireless Device Over-the-Air Performance

## CTIA 01.22 Test Methodology, SISO, Millimeter Wave

---

Version 4.0.1

November 2022

**© 2001 - 2022 CTIA Certification. All Rights Reserved.**

Any reproduction, modification, alteration, creation of a derivative work, or transmission of all or any part of this publication ("Test Plan"), in any form, by any means, whether electronic or mechanical, including photocopying, recording, or via any information storage and retrieval system, without the prior written permission of CTIA Certification, is unauthorized and strictly prohibited by federal copyright law. This Test Plan is solely for use within the CTIA Certification Program. Any other use of this Test Plan is strictly prohibited unless authorized by CTIA Certification or its assigns in writing.

## Use Instructions

All testing shall be performed in a CTIA Certification Authorized Test Lab and shall be initiated through one of the following methods:

1. By submitting a PTCRB or IoT Network Certified device certification request at <https://certify.ptcrb.com/>
2. By submitting an OTA Test Plan use request at <https://certify.ctiacertification.org/>

CTIA Certification LLC  
1400 16th Street, NW  
Suite 600  
Washington, DC 20036

1.202.785.0081

[programs@ctiacertification.org](mailto:programs@ctiacertification.org)

<https://ctiacertification.org/test-plans/>

# Table of Contents

Section 1	5G Millimeter-Wave Test Overview .....	5
1.1	Overview .....	5
1.2	Acronyms and Definitions .....	5
1.3	Document References .....	8
Section 2	Introduction to Measurements and Test Methods .....	9
2.1	Indirect Far-Field (IFF) based on Compact Antenna Test Range (CATR).....	9
2.1.1	Description .....	9
2.1.2	CATR Coordinate System .....	10
2.1.3	Quiet Zone Dimension .....	11
2.1.4	Quality of the Quiet Zone (QoQZ) .....	11
2.1.5	Measurement Distance.....	11
Section 3	Test Procedures - Transmitter .....	12
3.1	TX Beam Peak Search Procedure .....	12
3.2	Maximum Output Power – EIRP .....	13
3.3	Maximum Output Power – TRP .....	14
3.4	Maximum Output Power - Spherical Coverage .....	15
Section 4	Test Procedure – Receiver .....	16
4.1	RX Beam Peak Search Procedure .....	16
4.2	REFSENS – EIS .....	17
4.3	REFSENS – Spherical Coverage .....	18
Section 5	Measurement Uncertainty .....	19
5.1	EIRP Tests.....	19
5.2	TRP Tests .....	19
5.3	EIRP Spherical Coverage.....	20
5.4	EIS Tests .....	21
5.5	EIS Spherical Coverage .....	22
5.6	Criteria – Maximum Test System Uncertainty .....	23
Section 6	Measurement Grids .....	25
6.1	TRP Measurement Grids .....	25
6.2	Beam Peak Search Measurement Grids .....	25
6.3	Spherical Coverage Measurement Grids .....	25
6.3.1	Clarification of Min EIRP/Max EIS at Target CDF/CCDF Value.....	26
Appendix A	Revision History .....	29

## List of Figures

Figure 2.1.1-1 Working Principle for Rx Testing in a CATR .....	9
Figure 2.1.1-2 Working Principle for Tx Testing in a CATR.....	10
Figure 2.1.2-1 Example of IFF: CATR Measurement Setup.....	11
Figure 6.3.1-1 Sample CDF Curve for a Coarse Measurement Grid.....	27
Figure 6.3.1-2 Illustration of CDF Scenarios, a) CDF Target is Not Met with any EIRP Value, b) CDF Target Is Met with One or More EIRP Values .....	28

## List of Tables

Table 1.2-1 Acronyms and Definitions .....	5
Table 5.1-1 Uncertainty Contributions for EIRP Measurements.....	19
Table 5.2-1 Uncertainty Contributions for TRP Measurements .....	20
Table 5.3-1 Uncertainty Contributions for EIRP Spherical Coverage Measurements .....	21
Table 5.4-1 Uncertainty Contributions for EIS Measurements .....	22
Table 5.5-1 Uncertainty Contributions for EIS Spherical Coverage Measurements.....	23
Table 5.6-1 Maximum Test System Uncertainty for Different Test Cases.....	24

## Section 1 5G Millimeter-Wave Test Overview

### 1.1 Overview

This test plan presents the individual test procedures organized by type of test (Transmitter, Receiver).

The testing requirements fall into 4 categories:

- Characterizing the basic performance of the test chamber
- Measuring the path loss of the test system,
- Measuring the TX and RX beam peak direction
- Measuring the TX and RX performance of the wireless device

The test methodologies permitted for evaluating the TX and RX performance as part of the CTIA Certification program are introduced in [Section 2](#). The basic performance of the test chamber is covered in [CTIA 01.73 \[1\]](#); The site validation method for the amplitude inside the Quiet Zone (QZ) in Section 7 of [CTIA 01.73 \[1\]](#) is used to determine the uncertainty contribution of the test system; the pass/fail site validation method for the phase inside the QZ is outlined in Section 8 of [CTIA 01.73 \[1\]](#). Those quality of quiet zone results shall be supplied as part of the ATL authorization process. Corrections for the path loss of the test system, including range length, measurement antenna, cables, amplifiers, etc. are determined using the range reference measurement described in Section 4 of [CTIA 01.73 \[1\]](#). The measurement of the wireless device is covered in [Section 3](#) for radiated power measurements and [Section 4](#) for sensitivity measurements. The respective beam peak search procedures to determine the directions towards which the DUT forms the TX/RX beams are included in [Section 3](#) and [Section 4](#). The overall measurement uncertainty is described in [Section 5](#). [Section 6](#) outlines the measurement grid requirements for the select tests defined in this test plan.

### 1.2 Acronyms and Definitions

The following specialized terms and acronyms are used throughout this document.

Table 1.2-1 Acronyms and Definitions

Acronym	Definition
AUT	Antenna Under Test
Beam correspondence	The ability of the UE to select a suitable beam for UL transmission based on DL measurements with or without relying on UL beam sweeping
BW	Bandwidth
CATR	Compact Antenna Test Range
ATL	Authorized Testing Laboratory
CCDF	Complementary Cumulative Distribution Function
CDF	Cumulative Distribution Function
CPE	Customer Premises Equipment

Acronym	Definition
C_RNTI	Cell Radio Network Temporary Identity
D	DUT Radiating Aperture
DC	Dual Connectivity
DFT-s-OFDM	Discrete Fourier Transform-spread-OFDM
DUT	Device Under Test
EIRP	Effective Isotropic Radiated Power
EIS	Equivalent Isotropic Sensitivity
EN-DC	E-UTRA/NR DC
DCI	Downlink Control Information
DUT	Device Under Test
FR1	Frequency Range 1
FR2	Frequency Range 2
HARQ	Hybrid Automatic Repeat ReQuest
MOP	Maximum Output Power
MTSU	Maximum Test System Uncertainty
MU	Measurement Uncertainty
NR	New Radio
OFDM	Orthogonal Frequency-Division Multiplexing
OTA	Over The Air
PDCCH	Physical Downlink Control Channel
PDF	Probability Density Function
Pol <sub>Link</sub>	Polarization, either $\theta$ or $\phi$ , of the DL signal transmitted by the test equipment through the measurement antenna for the DUT to form the TX/RX beam towards it
Pol <sub>Meas</sub>	Polarization, either $\theta$ or $\phi$ , of the measurement antenna of the test equipment for the measurement being performed
PUSCH	Physical Uplink Shared Channel
REFSENS	Reference Sensitivity
RF	Radio Frequency

Acronym	Definition
RMC	Reference Measurement Channel
RX	Receive
RX beam peak direction	Direction ( $\theta, \phi$ ) where the best receiver performance is found
SCS	Sub-Carrier Spacing
SS	System Simulator
Test System	The controlled propagation environment used for evaluation of the Device Under Test (DUT). In the context of this version of this test specification, the Compact Antenna Test Range (CATR) is the only valid test system
Test Methodology	The process used to execute tests against the DUT using the Test System(s) specified by this document. In the context of this version of this test specification, the Indirect Far Field methodology based on Compact Antenna Test Range (CATR) is the only permitted test methodology
TRP	Total Radiated Power
TX	Transmit
TX beam peak direction	Direction ( $\theta, \phi$ ) where the maximum total component of EIRP is found
Quiet Zone	The portion of the useable volume within the test system into which the DUT can be placed and in which the test criteria are met within the applicable uncertainty limits
QoQZ	Quality of Quiet Zone
QZ	Quiet Zone
UBF	UE Beamlock test Function
UE	User Equipment
UL	Uplink
$\theta$	Denotes the zenith angle (in degrees) within the spherical co-ordinate system, as well as measurement antenna polarization along the direction of motion of the zenith axis rotation
$\phi$	Denotes the azimuth angle (in degrees) within the spherical co-ordinate system, as well as measurement antenna polarization along the direction of motion of the azimuth axis rotation

### 1.3 Document References

The following documents are referenced in this test plan:

Document Number, Document Name	
[1]	CTIA 01.73, <i>Supporting Procedures</i>
[2]	3GPP TS 38.509, 5GS; <i>Special conformance testing functions for User Equipment (UE)</i>
[3]	CTIA 01.70, <i>Measurement Uncertainty</i>
[4]	CTIA 01.71, <i>Positioning Guidelines</i>
[5]	3GPP TS 38.521-2, NR; <i>User Equipment (UE) Conformance Specification; Radio Transmission and Reception</i>
[6]	CTIA 01.50, <i>Wireless Technology, 3GPP Radio Access Technologies</i>
[7]	3GPP TS 38.508-1, 5GS; <i>User Equipment (UE) Conformance Specification</i>
[8]	3GPP TS 38.521-3, NR; <i>User Equipment (UE) Conformance Specification; Radio Transmission and Reception</i>
[9]	CTIA 01.90, <i>Informative Reference Material</i>



## Section 2 Introduction to Measurements and Test Methods

This section is outlining the permitted OTA test methods suitable for the UE OTA performance test cases outlined in this test plan.

### 2.1 Indirect Far-Field (IFF) based on Compact Antenna Test Range (CATR)

#### 2.1.1 Description

The IFF method utilizing a CATR creates a far-field environment in relatively close proximity of the parabolic reflector which serves as collimator transforming spherical waves into plane waves within the desired quiet zone. Figure 2.1.1-1 and Figure 2.1.1-2 demonstrate the reciprocity of the CATR system concept.

For RX testing, as illustrated in Figure 2.1.1-1 the probe/feed antenna placed near the focal point of the reflector radiates a spherical wave towards the reflector which collimates it into a planar wave front received by the DUT. The focal length is approximately the distance between the feed and the reflector. On the other hand, for TX testing, as illustrated in Figure 2.1.1-2 the radiation pattern from the DUT can be described as a series of plane waves propagating in different directions and the probe/ feed antenna receives only the focused beam from the plane wave directed straight at the reflector.

Inside the quiet zone, a planar wave front (uniform amplitude and phase) is achieved. Amplitude uniformity is dependent on the feed pattern, feed alignment, and reflector design while phase planarity is mainly dependent on feed alignment and reflector design. The polarization purity is mainly dependent on the parabolic system geometry considering high polarization purity feeds.

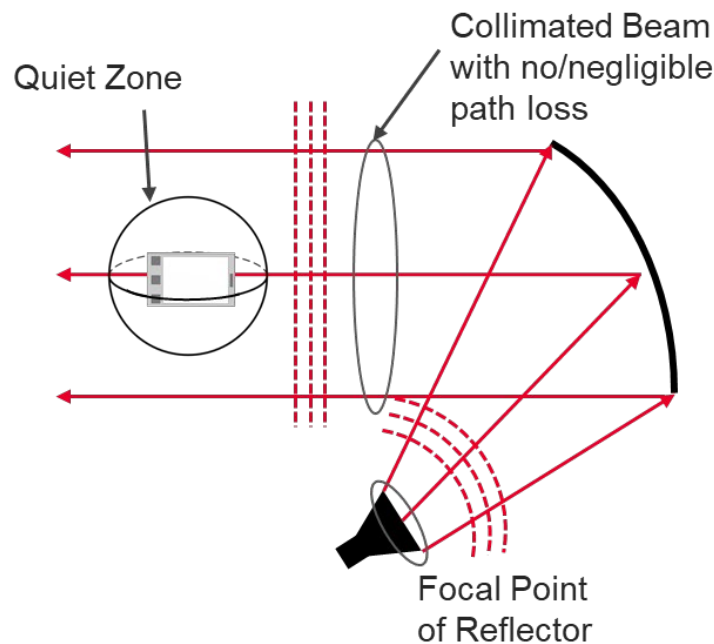

Figure 2.1.1-1 Working Principle for Rx Testing in a CATR

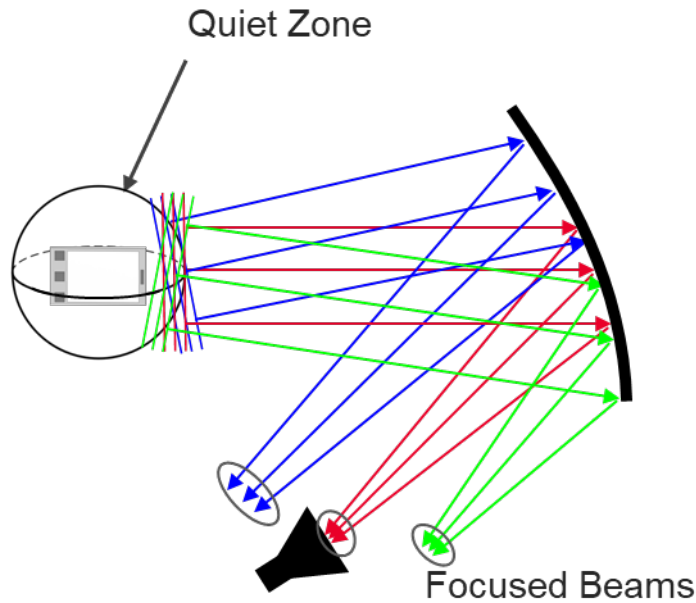

Figure 2.1.1-2 Working Principle for Tx Testing in a CATR

The key aspects of this test method setup are:

- A positioning system such that the angle between the dual-polarized measurement antenna and the DUT has at least two axes of freedom and maintains a polarization reference.
- Before performing the UE Beamlock test Function (UBF) identified in *3GPP TS 38.509 [2]* the measurement probe acts as a link antenna maintaining polarization reference with respect to the DUT. Once the beam is locked, the link may be passed to the link antenna which maintains reliable signal level with respect to the DUT.
- For setups intended for measurements of UE RF characteristics in EN-DC mode with one UL configuration, an LTE link antenna is used to provide the LTE link to the DUT. The LTE link antenna provides a stable LTE signal without precise path loss or polarization control.
- For setups intended for measurements in NR CA mode with FR1 and FR2 inter-band NR CA, test setup provides NR FR1 link to the DUT. The NR FR1 link has a stable and noise-free signal without precise path loss or polarization control.

### 2.1.2 CATR Coordinate System

The IFF CATR measurement setup for FR2 is shown in [Figure 2.1.2-1](#). The relative orientation of the coordinate system with respect to the reflector and the axes of rotation apply to any CATR measurement setup.

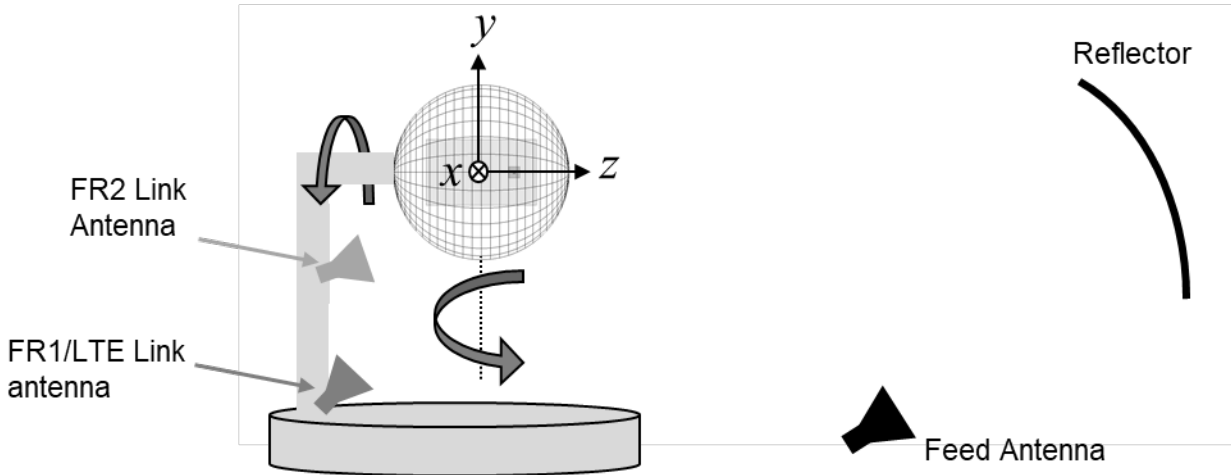

Figure 2.1.2-1 Example of IFF: CATR Measurement Setup

### 2.1.3 Quiet Zone Dimension

The quiet zone shall be large enough to fully contain the DUT. The spherical quiet zone shall have a radius of 150 mm to accommodate smartphone UEs, CPEs, tablets, and small handheld DUTs. The device types are listed as examples and other device types are not precluded. In either case, the DUT shall be fully contained in one of the quiet zone sizes defined herein for the entire duration of the test. The device types are listed as examples and other device types are not precluded. In either case, the DUT shall be fully contained in one of the quiet zone sizes defined herein for the entire duration of the test.

### 2.1.4 Quality of the Quiet Zone (QoQZ)

The QoQZ shall be measured for the frequencies defined in *CTIA 01.73 [1]* Section 3. The measured QoQZ performance is used in uncertainty calculations for the appropriate QoQZ dimension utilized for the DUT. The amplitude QoQZ is outlined in Section 7 of *CTIA 01.73 [1]* is used to determine the uncertainty contribution of the test system; the pass/fail site validation method for the phase inside the QZ is outlined in Section 8 of *CTIA 01.73 [1]*.

### 2.1.5 Measurement Distance

The CATR system does not require a measurement distance of  $R > 2D^2/\lambda$  to achieve a plane wave as in a conventional anechoic chamber test methodology (direct far-field). Instead, for the CATR system, the far-field distance is seen as the focal length.

The measurement distance for any CATR system implementation shall be adequate to meet the quiet zone dimensions defined in Section 2.1.3.

As the CATR generates a plane wave with no free space path loss inside the quiet zone, the influence of measurement distance on measurement uncertainty can be considered as zero as defined in *CTIA 01.70 [3]*.

## Section 3 Test Procedures - Transmitter

This section outlines the test procedures for the transmitter test cases for this test plan.

For the test environmental conditions described in *3GPP TS 38.521-2* [5], only the normal conditions shall be applied, i.e., normal temperature and normal voltage.

The vendor shall submit to the ATL a declaration of the primary mechanical mode as referenced in this test plan.

The TX procedures in this section shall assume that the DUT autonomously chooses the corresponding TX beam for PUSCH transmission using downlink reference signals to transmit in the direction of the incoming DL signal, which is based on beam correspondence without relying on UL beam sweeping.

### 3.1 TX Beam Peak Search Procedure

The purpose of this procedure is to determine the TX beam peak direction where the maximum total component of EIRP is found.

The measurement system shall be configured as specified in [Section 2](#). The power radiated by the DUT in the FR2 measurement path shall be measured using a calibrated RF measuring instrument, e.g., a gNB emulator, spectrum analyzer, or power meter capable of averaging across at least one subframe (1ms).

The test conditions are defined in Section 5.2.1.1 of *CTIA 01.50* [6].

The TX beam peak procedure is defined as follows:

1. Select any of the three alignment options (1, 2, or 3) from Table 4.1-1 through Table 4.1-3 in *CTIA 01.71* [4] to mount the DUT inside the QZ.
2. Position the DUT in DUT orientation 1 from Table 4.1-1 through Table 4.1-3 in *CTIA 01.71* [4].
3. Connect the SS (System Simulator) with the DUT through the reference measurement antenna with  $Pol_{Link} = \theta$  polarization to form the TX beam towards the measurement antenna. Allow at least BEAM\_SELECT\_WAIT\_TIME (defined in Annex K.1.1 of *3GPP TS 38.521-2* [5]) for the UE TX beam selection to complete. Continuously send power control “up” commands in every uplink scheduling information to the UE; allow at least 200 ms after the first TPC command in this step to ensure that the UE transmits at its maximum output power before continuing.
  - a. SS activates the UE Beamlock Function (UBF) by performing the procedure as specified in *3GPP TS 38.508-1* [7], clause 4.9.2 using condition TX only
  - b. Measure the mean power  $P_{meas}(Pol_{Meas} = \theta, Pol_{Link})$  of the modulated signal arriving at the power measurement equipment
  - c. Calculate EIRP ( $Pol_{Meas} = \theta, Pol_{Link}$ ) by adding the composite loss of the entire transmission path for utilized signal path,  $L_{EIRP,\theta}$ , and frequency to the measured power  $P_{meas}(Pol_{Meas} = \theta, Pol_{Link})$ .
  - d. Measure the mean power  $P_{meas}(Pol_{Meas} = \phi, Pol_{Link})$  of the modulated signal arriving at the power measurement equipment.
  - e. Calculate EIRP ( $Pol_{Meas} = \phi, Pol_{Link}$ ) by adding the composite loss of the entire transmission path for utilized signal path,  $L_{EIRP,\phi}$ , and frequency to the measured power  $P_{meas}(Pol_{Meas} = \phi, Pol_{Link})$

- f. Calculate total  $EIRP(Pol_{Link} = \theta) = EIRP(Pol_{Meas} = \theta, Pol_{Link}) + EIRP(Pol_{Meas} = \phi, Pol_{Link})$ .
  - g. SS deactivates the UBF by performing the procedure as specified in *3GPP TS 38.508-1* [7], clause 4.9.3.
4. Connect the SS with the DUT through the measurement antenna with  $Pol_{Link} = \phi$  polarization to form the TX beam towards the measurement antenna. Allow at least BEAM\_SELECT\_WAIT\_TIME for the UE TX beam selection to complete. Perform steps a-g from Step 3.
  5. Advance to the next grid point and repeat steps 3 and 4 until measurements within zenith range  $0^\circ \leq \theta \leq 90^\circ$  have been completed,
  6. After the measurements within zenith range  $0^\circ \leq \theta \leq 90^\circ$  have been completed and:
    - a. if the re-positioning concept is applied to the TX test cases, position the device in DUT orientation 2 (either options 1 or 2) for the alignment option selected in Step 1. For the TX beam peak search in the second hemisphere, continue steps 3 and 4 for the range of zenith angles  $90^\circ < \theta \leq 0^\circ$ .
    - b. If the re-positioning concept is not applied to the TX test cases, continue steps 3 and 4 for the range of zenith angles  $90^\circ < \theta \leq 180^\circ$

The TX beam peak direction is where the maximum total component of  $EIRP(Pol_{Link} = \theta)$  or  $EIRP(Pol_{Link} = \phi)$  is found.

The minimum number of measurement grid points for the TX beam peak search are outlined in Section 6.2.

### 3.2 Maximum Output Power – EIRP

The intent of this test procedure is to measure the total component of the EIRP in the maximum TX beam peak direction found in Section 3.1.

The EN-DC connections are established as outlined in Section 5.2.1.1 of *CTIA 01.50* [6]. The system simulator and DUT shall be configured per clause 6.2B.1.4.1 of *3GPP TS 38.521-3* [8] for this test case with the exception of the test conditions defined in *CTIA 01.50* [6], Section 5.2.1.1.

The test procedure for maximum output power EIRP at the TX beam peak direction is defined as follows:

1. Select any of the three alignment options (1, 2, or 3) from Table 4.1-1 through Table 4.1-3 in *CTIA 01.71* [4] to mount the DUT inside the QZ.
2. If the re-positioning concept is not applied to the TX test cases, position the device in DUT orientation 1. If the re-positioning concept is applied to the TX test cases,
  - a. Position the device in DUT orientation 1 from *CTIA 01.71* [4], Section 4.1, if the maximum beam peak direction is within zenith angular range  $0^\circ \leq \theta \leq 90^\circ$  for the alignment option selected in step 1.
  - b. Position the device in DUT orientation 2 (either options 1 or 2) from *CTIA 01.71* [4], Section 4.1, if the maximum beam peak direction is within zenith angular range  $90^\circ < \theta \leq 180^\circ$  for DUT orientation 1 for the alignment option selected in step 1.
3. SS sends uplink scheduling information for each UL HARQ process via PDCCH DCI format [0\_1] for C\_RNTI to schedule the UL RMC according to Table 6.2.1.1.4.1-1 of *3GPP TS 38.521-2* [5]. Since the UL has no payload and no loopback data to send, the UE sends uplink MAC padding bits on the UL RMC. Messages to configure the appropriate uplink modulation in *3GPP TS 38.508-1* [7], clause 4.6.

4. Set the DUT in the TX beam peak direction found in Section 3.1.
  - a. Connect the SS with the DUT through the measurement antenna with polarization reference  $Pol_{Link}$  that yielded the maximum TX beam peak to form the TX beam towards the TX beam peak direction and respective polarization. Allow at least BEAM\_SELECT\_WAIT\_TIME for the UE TX beam selection to complete.
  - b. Continuously send uplink power control "up" commands in every uplink scheduling information to the UE; allow at least 200 ms starting from the first TPC command in this step to ensure that the UE transmits at its maximum output power before continuing.
  - c. SS activates the UBF by performing the procedure as specified in 3GPP TS 38.508-1 [7], clause 4.9.2 using condition TX only.
  - d. Measure the mean power  $P_{meas}(Pol_{Meas} = \theta, Pol_{Link})$  of the modulated signal arriving at the power measurement equipment (such as a spectrum analyzer, power meter, or gNB emulator).
  - e. Calculate EIRP ( $Pol_{Meas} = \theta, Pol_{Link}$ ) by adding the composite loss of the entire transmission path for utilized signal path,  $L_{EIRP, \theta}$ , and frequency to the measured power  $P_{meas}(Pol_{Meas} = \theta, Pol_{Link})$
  - f. Measure the mean power  $P_{meas}(Pol_{Meas} = \phi, Pol_{Link})$  of the modulated signal arriving at the power measurement equipment.
  - g. Calculate EIRP ( $Pol_{Meas} = \phi, Pol_{Link}$ ) by adding the composite loss of the entire transmission path for utilized signal path,  $L_{EIRP, \phi}$  and frequency to the measured power  $P_{meas}(Pol_{Meas} = \phi, Pol_{Link})$
5. Calculate the resulting total EIRP ( $Pol_{Link}$ ) for the chosen  $Pol_{Link}$  of  $\theta$  or  $\phi$  as follows:
 
$$EIRP(Pol_{Link}) = EIRP(Pol_{Meas} = \theta, Pol_{Link}) + EIRP(Pol_{Meas} = \phi, Pol_{Link})$$

### 3.3 Maximum Output Power – TRP

The intent of this test procedure is to measure total radiated power of the DUT with the UL beam formed in the maximum TX beam peak direction found in Section 3.1.

The minimum number of measurement grid points including allowances to skip measurements near the pole at  $\theta=180^\circ$  for the TRP measurement are outlined in Section 6.1.

The EN-DC connections are established as outlined in Section 5.2.1.1 of CTIA 01.50 [6]. The system simulator and DUT shall be configured per clause 6.2B.1.4.1 of 3GPP TS 38.521-3 [8] for this test case with the exception of the test conditions defined in CTIA 01.50 [6], Section 5.2.1.1.

The test procedure for TRP is as follows:

1. Select any of the three alignment options (1, 2, or 3) from Table 4.1-1 through Table 4.1-3 in CTIA 01.71 [4] to mount the DUT inside the QZ.
2. If the re-positioning concept is not applied to the TX test cases, position the device in DUT orientation 1. If the re-positioning concept is applied to the TX test cases,
  - a. position the device in DUT orientation 1 from CTIA 01.71 [4], Section 4.1, if the maximum beam peak direction is within zenith angular range  $0^\circ \leq \theta \leq 90^\circ$  for the alignment option selected in step 1.
  - b. Position the device in DUT orientation 2 (either options 1 or 2) from CTIA 01.71 [4], Section 4.1, if the maximum beam peak direction is within zenith angular range  $90^\circ < \theta \leq 180^\circ$  for DUT orientation 1 for the alignment option selected in step 1.

3. SS sends uplink scheduling information for each UL HARQ process via PDCCH DCI format [0\_1] for C\_RNTI to schedule the UL RMC according to Table 6.2.1.1.4.1-1 of 3GPP TS 38.521-2 [5]. Since the UL has no payload and no loopback data to send, the UE sends uplink MAC padding bits on the UL RMC. Messages to configure the appropriate uplink modulation are defined in 3GPP TS 38.508-1 [7], clause 4.6.
4. Set the DUT in the TX beam peak direction found in Section 3.1.
  - a. Connect the SS with the DUT through the downlink antenna with desired polarization reference  $Pol_{Link}$  that yielded the maximum TX beam peak to form the TX beam towards the desired TX beam direction and respective polarization. Allow at least BEAM\_SELECT\_WAIT\_TIME for the UE TX beam selection to complete.
  - b. Continuously send uplink power control "up" commands in every uplink scheduling information to the UE; allow at least 200 ms after the first TPC command in this step to ensure that the UE transmits at its maximum output power before continuing.
  - c. SS activates the UBF for the entire duration of the test by performing the procedure as specified in 3GPP TS 38.508-1 [7], clause 4.9.2 using condition TX only.
5. For each measurement point, measure  $P_{meas}(Pol_{Meas} = \theta, Pol_{Link})$  and  $P_{meas}(Pol_{Meas} = \phi, Pol_{Link})$
6. Calculate EIRP ( $Pol_{Meas} = \theta, Pol_{Link}$ ) and EIRP ( $Pol_{Meas} = \phi, Pol_{Link}$ ) by adding the composite loss of the entire transmission path for utilized signal paths,  $L_{EIRP,\theta}$ ,  $L_{EIRP,\phi}$  and frequency to the respective measured powers  $P_{meas}$ .
7. The TRP value for the measurement grid is calculated using the TRP integration approaches outlined in CTIA 01.90 [9] Section 3.

### 3.4 Maximum Output Power - Spherical Coverage

The intent of this test procedure is to verify that the spatial coverage of the UE in expected directions is acceptable.

The EN-DC connections are established as outlined in Section 5.2.1.1 of CTIA 01.50 [6]. The system simulator and DUT shall be configured per clause 6.2B.1.4.2 of 3GPP TS 38.521-3 [8] for this test case with the exception of the test conditions defined in CTIA 01.50 [6], Section 5.2.1.1.

The  $EIRP_{50\%-CDF}$  is obtained from the Cumulative Distribution Function (CDF) computed using maximum ( $EIRP(Pol_{Link} = \theta, EIRP(Pol_{Link} = \phi))$ ) for all grid points collected during the TX beam peak search in Section 3.1. Alternatively, the  $EIRP_{50\%-CDF}$  can be obtained from the CDF computed using maximum ( $EIRP(Pol_{Link} = \theta, EIRP(Pol_{Link} = \phi))$ ) using the procedure outlined in Section 3.1 but for the minimum number of grid points outlined in Section 6.3.

When using constant step size measurement grids, a theta-dependent correction shall be applied, i.e., the PDF contribution for each measurement point is scaled by the normalized Clenshaw-Curtis weights  $W(\theta)/W(\theta = 90^\circ)$  as outlined in CTIA 01.90 [9] Section 4.1.1.

## Section 4 Test Procedure – Receiver

This section outlines the test procedures for the receiver test cases for this test plan.

For the test environmental conditions *3GPP TS 38.521-2* [5], only the normal conditions shall be applied, i.e., normal temperature and normal voltage.

### 4.1 RX Beam Peak Search Procedure

The purpose of this procedure is to determine the RX beam peak direction where the minimum averaged EIS is found.

The test conditions are defined in Section 5.2.1.2 of *CTIA 01.50* [6].

The RX beam peak procedure is defined as follows:

1. Select any of the three alignment options (1, 2, or 3) from Table 4.1-1 through Table 4.1-3 in *CTIA 01.71* [4] to mount the DUT inside the QZ.
2. Position the DUT in DUT orientation 1 from Table 4.1-1 through Table 4.1-3 in *CTIA 01.71* [4].
3. Connect the SS with the DUT through the measurement antenna with  $Pol_{Link} = \theta$  polarization to form the RX beam towards the measurement antenna. Continuously send uplink power control "up" commands in every uplink scheduling information to the UE; allow at least 200 ms for the UE to reach  $P_{UMAX}$ . Allow at least BEAM\_SELECT\_WAIT\_TIME (defined in *3GPP TS 38.521-2* [5], annex K.1.1) for the UE RX beam selection to complete.
4. Determine EIS ( $Pol_{Meas} = \theta, Pol_{Link} = \theta$ ) for  $\theta$ -polarization, i.e., the power level for the  $\theta$ -polarization, at which the throughput exceeds the requirements for the specified reference measurement channel. For power steps near the sensitivity level, measure the average throughput for a duration sufficient to achieve statistical significance according to *3GPP TS 38.521-2* [5], clause H.2.2. The downlink power step size shall be no more than 0.2 dB when the RF power level is near the sensitivity level.
5. Connect the SS with the DUT through the measurement antenna with  $Pol_{Link} = \phi$  polarization to form the RX beam towards the measurement antenna. Continuously send uplink power control "up" commands in every uplink scheduling information to the UE; allow at least 200 ms for the UE to reach  $P_{UMAX}$ . Allow at least BEAM\_SELECT\_WAIT\_TIME for the UE RX beam selection to complete.
6. Determine EIS ( $Pol_{Meas} = \phi, Pol_{Link} = \phi$ ) for  $\phi$ -polarization, i.e., the power level for the  $\phi$ -polarization, at which the throughput exceeds the requirements for the specified reference measurement channel. For power steps near the sensitivity level, measure the average throughput for a duration sufficient to achieve statistical significance according to *3GPP TS 38.521-2* [5], clause H.2.2. The downlink power step size shall be no more than 0.2 dB when the RF power level is near the sensitivity level.
7. Advance to the next grid point and repeat steps 3 through 6 until measurements within the zenith range of  $0^\circ \leq \theta \leq 90^\circ$  have been completed
8. After the measurements within zenith range  $0^\circ \leq \theta \leq 90^\circ$  have been completed and
  - a. If the re-positioning concept is applied to the RX test cases, position the device in DUT orientation 2 (either options 1 or 2) from Table 4.1-1 through Table 4.1-3 in *CTIA 01.71* [4] for the alignment option selected in Step 1. For the RX beam peak



- search in the second hemisphere, perform steps 3 through 6 for the range of zenith angles  $90^\circ < \theta \leq 0^\circ$ .
- b. If the re-positioning concept is not applied to the RX test cases, continue steps 3 through 6 for the range of zenith angles  $90^\circ < \theta \leq 180^\circ$
9. Calculate the resulting averaged EIS for each grid point as:

$$EIS_{avg} = 2 * [1/EIS (Pol_{Meas} = \theta, Pol_{Link} = \theta) + 1/EIS (Pol_{Meas} = \phi, Pol_{Link} = \phi)]^{-1}$$

The RX beam peak direction is where the minimum  $EIS_{avg}$  is found.

The minimum number of measurement grid points for the RX beam peak search are outlined in Section 6.2.

## 4.2 REFSENS – EIS

The intent of this test procedure is to measure the averaged EIS in the RX beam peak direction found in Section 4.1. The EN-DC connections are established as outlined in Section 5.2.1.2 of CTIA 01.50 [6]. The system simulator and DUT shall be configured per clause 7.3B.2.4 of 3GPP TS 38.521-3 [8] for this test case with the exception of the test conditions defined in CTIA 01.50 [6], Section 5.2.1.2.

The test procedure for is defined as follows:

1. Select any of the three alignment options (1, 2, or 3) from Table 4.1-1 through Table 4.1-3 in CTIA 01.71 [4] to mount the DUT inside the QZ.
2. If the re-positioning concept is not applied to the RX test cases, position the device in DUT orientation 1. If the re-positioning concept is applied to the RX test cases:
  - a. position the device in DUT orientation 1 from CTIA 01.71 [4], Section 4.1, if the maximum beam peak direction is within zenith angular range  $0^\circ \leq \theta \leq 90^\circ$  for the alignment option selected in step 1,
  - b. position the device in DUT orientation 2 (either options 1 or 2) from CTIA 01.71 [4], Section 4.1, the maximum beam peak direction is within zenith angular range  $90^\circ < \theta \leq 180^\circ$  for DUT orientation 1 for the alignment option selected in step 1.
3. Connect the SS with the DUT through the measurement antenna with  $Pol_{Link} = \theta$  polarization to form the RX beam towards the RX beam peak direction. Send continuously uplink power control "up" commands in every uplink scheduling information to the UE; allow at least 200 ms for the UE to reach  $P_{UMAX}$ . Allow at least BEAM\_SELECT\_WAIT\_TIME (defined in 3GPP TS 38.521-2 [5], clause K.1.1, for the UE RX beam selection to complete.
4. Determine  $EIS(Pol_{Meas} = \theta, Pol_{Link} = \theta)$  for  $\theta$ -polarization, i.e., the power level for the  $\theta$ -polarization at which the throughput exceeds the requirements for the specified reference measurement channel. For power steps near the sensitivity level, measure the average throughput for a duration sufficient to achieve statistical significance according to of 3GPP TS 38.521-2 [5], clause H.2.2. The downlink power step size shall be no more than 0.2 dB when the RF power level is near the sensitivity level.
5. Connect the SS with the DUT through the measurement antenna with  $Pol_{Link} = \phi$  polarization to form the RX beam towards the RX beam peak direction. Continuously send uplink power control "up" commands in every uplink scheduling information to the UE; allow at least 200 ms for the UE to reach  $P_{UMAX}$ . Allow at least BEAM\_SELECT\_WAIT\_TIME for the UE RX beam selection to complete.

6. Determine  $EIS(Pol_{Meas} = \phi, Pol_{Link} = \phi)$  for  $\phi$ -polarization, i.e., the power level for the  $\phi$ -polarization at which the throughput exceeds the requirements for the specified reference measurement channel. For power steps near the sensitivity level, measure the average throughput for a duration sufficient to achieve statistical significance according to *3GPP TS 38.521-2* [5], clause H.2.2. The downlink power step size shall be no more than 0.2 dB when the RF power level is near the sensitivity level.
7. Calculate the resulting averaged EIS in the RX beam peak direction as:

$$EIS_{avg} = 2 * [1/EIS (Pol_{Meas} = \theta, Pol_{Link} = \theta) + 1/EIS (Pol_{Meas} = \phi, Pol_{Link} = \phi)]^{-1}$$

### 4.3 REFSSENS – Spherical Coverage

The intent of this test procedure is to verify that the spatial coverage of the UE in the expected directions is acceptable.

The EN-DC connections are established as outlined in Section 5.2.1.2 of *CTIA 01.50* [6]. The system simulator and DUT shall be configured per clause 7.3B.4 of *3GPP TS 38.521-3* [8] this test case with the exception of the test conditions defined in *CTIA 01.50* [6], Section 5.2.1.2.

The  $EIS_{50\%-CCDF}$  is obtained from the Complementary Cumulative Distribution Function (CCDF) computed from the  $EIS_{avg}$  measurements for all grid points collected during the RX beam peak search in Section 4.1. Alternatively, the  $EIS_{50\%-CCDF}$  can be obtained from the CCDF computed from the  $EIS_{avg}$  measurements using the procedure outlined in Section 4.1 but for the minimum number of grid points outlined in Section 6.3.

When using constant step size measurement grids, a theta-dependent correction shall be applied, i.e., the PDF contribution for each measurement point is scaled by the normalized Clenshaw-Curtis weights  $W(\theta)/W(\theta = 90^\circ)$  as outlined in *CTIA 01.90* [9], Section 4.1.1.

## Section 5 Measurement Uncertainty

### 5.1 EIRP Tests

The Effective Isotropic Radiated Power (EIRP) test method determines the unknown performance of the DUT by correcting the absolute power measurements at the input port of the test instrumentation using a relative correction value determined using the range reference measurement described in Section 4 of *CTIA 01.73 [1]*. This correction value offsets each power measurement back to the equivalent power that would have been radiated by a theoretical isotropic radiator in order to produce the same measured level. This corrected value is known as the EIRP.

In [Table 5.1-1](#), uncertainties are identified that belong to either the DUT measurement, the range reference measurement stage or both for the EIRP test case.

Table 5.1-1 Uncertainty Contributions for EIRP Measurements

UID	Description Of Uncertainty Contributions	Reference
<b>Stage 2: DUT Measurement</b>		
1	Positioning Misalignment	See Section 2.14 of <i>CTIA 01.70 [3]</i>
2	Measurement Distance	See Section 2.41 of <i>CTIA 01.70 [3]</i>
3	Quality of Quiet Zone	See Section 2.11.1 of <i>CTIA 01.70 [3]</i>
4	Mismatch	See Section 2.1 of <i>CTIA 01.70 [3]</i>
5	Chamber Standing Wave	See Section 2.14 of <i>CTIA 01.70 [3]</i>
6	RF Power Measurement Equipment	See Section 2.4 of <i>CTIA 01.70 [3]</i>
7	Phase Curvature	See Section 2.33 of <i>CTIA 01.70 [3]</i>
8	Amplifiers	See Section 2.7 of <i>CTIA 01.70 [3]</i>
9	Random Uncertainty	See Section 2.22 of <i>CTIA 01.70 [3]</i>
10	Influence of the XPD	See Section 2.34 of <i>CTIA 01.70 [3]</i>
11	Multiple Measurement Antennas	See Section 2.35 of <i>CTIA 01.70 [3]</i>
12	DUT Repositioning	See Section 2.18 of <i>CTIA 01.70 [3]</i>
<b>Stage 1: Range Reference Measurement</b>		
13	Mismatch	See Section 2.1 of <i>CTIA 01.70 [3]</i>
14	Amplifiers	See Section 2.7 of <i>CTIA 01.70 [3]</i>
15	Misalignment of Positioning System	See Section 2.15 of <i>CTIA 01.70 [3]</i>
16	Network Analyzer	See Section 2.6 of <i>CTIA 01.70 [3]</i>
17	Absolute Gain of the Calibration Antenna	See Section 2.8.1 of <i>CTIA 01.70 [3]</i>
18	Positioning and Pointing Misalignment between the Reference Antenna and the Measurement Antenna	See Section 2.16 of <i>CTIA 01.70 [3]</i>
19	Phase Center Offset of Calibration Antenna	See Section 2.36 of <i>CTIA 01.70 [3]</i>
20	Quality of Quiet Zone for Calibration Process	See Section 2.11.2 of <i>CTIA 01.70 [3]</i>
21	Influence of the Calibration Antenna Feed Path	See Section 2.37 of <i>CTIA 01.70 [3]</i>
22	Standing Wave between Reference Calibration Antenna and Measurement Antenna	See Section 2.32 of <i>CTIA 01.70 [3]</i>
23	Insertion Loss Variation	See Section 2.3 of <i>CTIA 01.70 [3]</i>
<b>Systematic Uncertainties</b>		
24	Influence of Noise	See Section 2.38 of <i>CTIA 01.70 [3]</i>
25	Systematic Error related to Beam Peak Search	See Section 2.39 of <i>CTIA 01.70 [3]</i>

### 5.2 TRP Tests

The Total Radiated Power (TRP) test method is based on the EIRP approach outlined in Section 5.1 but requires the integration of EIRPs across the total spherical surface to determine the TRP.

In [Table 5.2-1](#), uncertainties are identified that belong to either the DUT measurement, the range reference measurement stage or both for the TRP test case.

Table 5.2-1 Uncertainty Contributions for TRP Measurements

UID	Description of Uncertainty Contributions	Reference
<b>Stage 2: DUT Measurement</b>		
1	Positioning Misalignment	See Section 2.14 of <i>CTIA 01.70</i> [3]
2	Measurement Distance	See Section 2.41 of <i>CTIA 01.70</i> [3]
3	Quality of Quiet Zone	See Section 2.11.1 of <i>CTIA 01.70</i> [3]
4	Mismatch	See Section 2.1 of <i>CTIA 01.70</i> [3]
5	Chamber Standing Wave	See Section 2.31 of <i>CTIA 01.70</i> [3]
6	RF Power Measurement Equipment	See Section 2.4 of <i>CTIA 01.70</i> [3]
7	Phase Curvature	See Section 2.33 of <i>CTIA 01.70</i> [3]
8	Amplifiers	See Section 2.7 of <i>CTIA 01.70</i> [3]
9	Random Uncertainty	See Section 2.22 of <i>CTIA 01.70</i> [3]
10	Influence of the XPD	See Section 2.34 of <i>CTIA 01.70</i> [3]
11	Influence of TRP Measurement Grid	See Section 2.21.3 of <i>CTIA 01.70</i> [3]
12	Multiple Measurement Antennas	See Section 2.35 of <i>CTIA 01.70</i> [3]
13	DUT Repositioning	See Section 2.18 of <i>CTIA 01.70</i> [3]
<b>Stage 1: Range Reference Measurement</b>		
14	Mismatch	See Section 2.1 of <i>CTIA 01.70</i> [3]
15	Amplifiers	See Section 2.7 of <i>CTIA 01.70</i> [3]
16	Misalignment of Positioning System	See Section 2.15 of <i>CTIA 01.70</i> [3]
17	Network Analyzer	See Section 2.6 of <i>CTIA 01.70</i> [3]
18	Absolute Gain of the Calibration Antenna	See Section 2.8.1 of <i>CTIA 01.70</i> [3]
19	Positioning and Pointing Misalignment between the Reference Antenna and the Measurement Antenna	See Section 2.16 of <i>CTIA 01.70</i> [3]
20	Phase Center Offset of Calibration Antenna	See Section 2.36 of <i>CTIA 01.70</i> [3]
21	Quality of Quiet Zone for Calibration Process	See Section 2.11.2 of <i>CTIA 01.70</i> [3]
22	Influence of the Calibration Antenna Feed Path	See Section 2.37 of <i>CTIA 01.70</i> [3]
23	Standing Wave between Reference Calibration Antenna and Measurement Antenna	See Section 2.32 of <i>CTIA 01.70</i> [3]
24	Insertion Loss Variation	See Section 2.3 of <i>CTIA 01.70</i> [3]
<b>Systematic Uncertainties</b>		
25	Influence of Noise	See Section 2.38 of <i>CTIA 01.70</i> [3]

### 5.3 EIRP Spherical Coverage

The EIRP Spherical Coverage test method is based on the EIRP approach outlined in Section 5.1 but requires the computation of the CDF of EIRPs measured on each grid point of the spherical surface.

In [Table 5.3-1](#), uncertainties are identified that belong to either the DUT measurement, the range reference measurement stage or both for the EIRP spherical coverage test case.

Table 5.3-1 Uncertainty Contributions for EIRP Spherical Coverage Measurements

UID	Description of Uncertainty Contributions	Reference
<b>Stage 2: DUT Measurement</b>		
1	Positioning Misalignment	See Section 2.14 of CTIA 01.70 [3]
2	Measurement Distance	See Section 2.41 of CTIA 01.70 [3]
3	Quality of Quiet Zone	See Section 2.11.1 of CTIA 01.70 [3]
4	Mismatch	See Section 2.1 of CTIA 01.70 [3]
5	Chamber Standing Wave	See Section 2.31 of CTIA 01.70 [3]
6	RF Power Measurement Equipment	See Section 2.4 of CTIA 01.70 [3]
7	Phase Curvature	See Section 2.33 of CTIA 01.70 [3]
8	Amplifiers	See Section 2.7 of CTIA 01.70 [3]
9	Random Uncertainty	See Section 2.22 of CTIA 01.70 [3]
10	Influence of the XPD	See Section 2.34 of CTIA 01.70 [3]
11	Multiple Measurement Antennas	See Section 2.35 of CTIA 01.70 [3]
12	DUT Repositioning	See Section 2.18 of CTIA 01.70 [3]
13	Influence of Spherical Coverage Grid	See Section 2.21.4 of CTIA 01.70 [3]
<b>Stage 1: Range Reference Measurement</b>		
14	Mismatch	See Section 2.1 of CTIA 01.70 [3]
15	Amplifiers	See Section 2.7 of CTIA 01.70 [3]
16	Misalignment of Positioning System	See Section 2.15 of CTIA 01.70 [3]
17	Network Analyzer	See Section 2.6 of CTIA 01.70 [3]
18	Absolute Gain of the Calibration Antenna	See Section 2.8.1 of CTIA 01.70 [3]
19	Positioning and Pointing Misalignment between the Reference Antenna and the Measurement Antenna	See Section 2.16 of CTIA 01.70 [3]
20	Phase Center Offset of Calibration Antenna	See Section 2.36 of CTIA 01.70 [3]
21	Quality of Quiet Zone for Calibration Process	See Section 2.11.2 of CTIA 01.70 [3]
22	Influence of the Calibration Antenna Feed Path	See Section 2.37 of CTIA 01.70 [3]
23	Standing Wave between Reference Calibration Antenna and Measurement Antenna	See Section 2.32 of CTIA 01.70 [3]
24	Insertion Loss Variation	See Section 2.3 of CTIA 01.70 [3]
<b>Systematic Uncertainties</b>		
25	Influence of Noise	See Section 2.38 of CTIA 01.70 [3]

## 5.4 EIS Tests

The Effective Isotropic Sensitivity (EIS) test method is similar to the EIRP method above, in that the range reference measurement outlined in Section 4 of *CTIA 01.73* [1] is used to correct the unknown performance of the DUT back to values relative to that of a theoretical isotropic receiver. In this case, the correction value offsets each sensitivity level measurement back to the equivalent sensitivity level of a theoretical isotropic receiver exposed to an incoming isotropic wave with the same magnitude. This corrected value is known as the EIS.

In [Table 5.4-1](#), uncertainties are identified that belong to either the DUT measurement, the range reference measurement stage or both for the EIS test case.

Table 5.4-1 Uncertainty Contributions for EIS Measurements

UID	Description of Uncertainty Contributions	Reference
<b>Stage 2: DUT Measurement</b>		
1	Positioning Misalignment	See Section 2.14 of CTIA 01.70 [3]
2	Measurement Distance	See Section 2.41 of CTIA 01.70 [3]
3	Quality of Quiet Zone	See Section 2.11.1 of CTIA 01.70 [3]
4	Mismatch	See Section 2.1 of CTIA 01.70 [3]
5	Chamber Standing Wave	See Section 2.31 of CTIA 01.70 [3]
6	gNB Emulator	See Section 2.4 of CTIA 01.70 [3]
7	Phase Curvature	See Section 2.33 of CTIA 01.70 [3]
8	Amplifiers	See Section 2.7 of CTIA 01.70 [3]
9	Random Uncertainty	See Section 2.22 of CTIA 01.70 [3]
10	Influence of the XPD	See Section 2.34 of CTIA 01.70 [3]
11	Multiple Measurement Antennas	See Section 2.35 of CTIA 01.70 [3]
12	DUT Repositioning	See Section 2.18 of CTIA 01.70 [3]
<b>Stage 1: Range Reference Measurement</b>		
13	Mismatch	See Section 2.1 of CTIA 01.70 [3]
14	Amplifiers	See Section 2.7 of CTIA 01.70 [3]
15	Misalignment of Positioning System	See Section 2.15 of CTIA 01.70 [3]
16	Network Analyzer	See Section 2.6 of CTIA 01.70 [3]
17	Absolute Gain of the Calibration Antenna	See Section 2.8.1 of CTIA 01.70 [3]
18	Positioning and Pointing Misalignment between the Reference Antenna and the Measurement Antenna	See Section 2.16 of CTIA 01.70 [3]
19	Phase Center Offset of Calibration Antenna	See Section 2.36 of CTIA 01.70 [3]
20	Quality of Quiet Zone for Calibration Process	See Section 2.11.2 of CTIA 01.70 [3]
21	Influence of the Calibration Antenna Feed Path	See Section 2.37 of CTIA 01.70 [3]
22	Standing Wave between Reference Calibration Antenna and Measurement Antenna	See Section 2.32 of CTIA 01.70 [3]
23	Insertion Loss Variation	See Section 2.3 of CTIA 01.70 [3]
<b>Systematic Uncertainties</b>		
24	Systematic Error related to Beam Peak Search	See Section 2.39 of CTIA 01.70 [3]

## 5.5 EIS Spherical Coverage

The EIS spherical coverage test method is based on the EIS approach outlined in Section 5.4 but requires the computation of the CCDF of EISs measured on each grid point of the spherical surface.

In Table 5.5-1, uncertainties are identified that belong to either the DUT measurement, the range reference measurement stage or both for the EIS spherical coverage test case.

Table 5.5-1 Uncertainty Contributions for EIS Spherical Coverage Measurements

UID	Description of Uncertainty Contributions	Reference
<b>Stage 2: DUT Measurement</b>		
1	Positioning Misalignment	See Section 2.14 of CTIA 01.70 [3]
2	Measurement Distance	See Section 2.41 of CTIA 01.70 [3]
3	Quality of Quiet Zone	See Section 2.11.1 of CTIA 01.70 [3]
4	Mismatch	See Section 2.1 of CTIA 01.70 [3]
5	Chamber Standing Wave	See Section 2.31 of CTIA 01.70 [3]
6	gNB Emulator	See Section 2.4 of CTIA 01.70 [3]
7	Phase Curvature	See Section 2.33 of CTIA 01.70 [3]
8	Amplifiers	See Section 2.7 of CTIA 01.70 [3]
9	Random Uncertainty	See Section 2.22 of CTIA 01.70 [3]
10	Influence of the XPD	See Section 2.34 of CTIA 01.70 [3]
11	Multiple Measurement Antennas	See Section 2.35 of CTIA 01.70 [3]
12	DUT Repositioning	See Section 2.18 of CTIA 01.70 [3]
13	Influence of Spherical Coverage Grid	See Section 2.21.4 of CTIA 01.70 [3]
<b>Stage 1: Range Reference Measurement</b>		
14	Mismatch	See Section 2.1 of CTIA 01.70 [3]
15	Amplifiers	See Section 2.7 of CTIA 01.70 [3]
16	Misalignment of Positioning System	See Section 2.15 of CTIA 01.70 [3]
17	Network Analyzer	See Section 2.6 of CTIA 01.70 [3]
18	Absolute Gain of the Calibration Antenna	See Section 2.8.1 of CTIA 01.70 [3]
19	Positioning and Pointing Misalignment between the Reference Antenna and the Measurement Antenna	See Section 2.16 of CTIA 01.70 [3]
20	Phase Center Offset of Calibration Antenna	See Section 2.36 of CTIA 01.70 [3]
21	Quality of Quiet Zone for Calibration Process	See Section 2.11.2 of CTIA 01.70 [3]
22	Influence of the Calibration Antenna Feed Path	See Section 2.37 of CTIA 01.70 [3]
23	Standing Wave between Reference Calibration Antenna and Measurement Antenna	See Section 2.32 of CTIA 01.70 [3]
24	Insertion Loss Variation	See Section 2.3 of CTIA 01.70 [3]
<b>Systematic Uncertainties</b>		
25	Systematic error related to EIS spherical coverage	See Section 2.40 of CTIA 01.70 [3]

## 5.6 Criteria – Maximum Test System Uncertainty

The results of the calculations for expanded uncertainty for all test cases measurements shall be reported, along with full documentation to support the resulting values. The test performance requirements shall not be adjusted by the measurement uncertainty when determining compliance of the DUTs.

The expanded uncertainties must not exceed the maximum test system uncertainty (MTSU) values in [Table 5.6-1](#) at a 95% confidence level.

Table 5.6-1 Maximum Test System Uncertainty for Different Test Cases

Expanded Uncertainty [dB]				
Test Case	FR2_1 (24.25GHZ- 32GHZ)	FR2_2 (32 GHZ - 40 GHZ)	FR2_3 (40 GHZ - 48 GHZ)	FR2_4 (48 GHZ - 52.6GHZ)
Maximum Output Power – EIRP	4.87	5.07	TBD	TBD
Maximum Output Power – TRP	4.40	4.60	TBD	TBD
Maximum Output Power – Spherical Coverage	4.58	5.18	TBD	TBD
REFSENS – EIS	5.19	5.19	TBD	TBD
REFSENS – Spherical Coverage	4.90	4.90	TBD	TBD



## Section 6 Measurement Grids

This test plan is currently applicable only to UE antennas with radiating aperture less than or equal to 5 cm. Measurement grids and measurement uncertainties for DUTs with antenna apertures greater than 5 cm have not been defined yet and can therefore not be certified using this test plan.

This section outlines important aspects of measurement grids including minimum number of grid points for constant step-size and constant density and the corresponding MU values. The PC3 analyses were based on an 8x2 antenna array.

### 6.1 TRP Measurement Grids

The TRP grid is used to determine the Total Radiated Power emitted by the DUT.

For Power Class 3 devices with radiating apertures of less than or equal to 5 cm, i.e., non-sparse antenna arrays, either of the following measurement grids and implementations were found to be the best trade-off between measurement uncertainties, measurement grid points, and test time. Either of the choices shall be used for this test plan:

- At least 135 measurement grid points for the constant density grid using the Charged Particle implementation with a standard deviation of 0.23 dB with the allowance to skip and interpolate measurements beyond  $165^\circ$  in  $\theta$
- At least 150 measurement grid points for the constant density grid using the Charged Particle implementation with a standard deviation of 0.25 dB with the allowance to skip and interpolate measurements beyond  $150^\circ$  in  $\theta$
- At least 192 unique measurement grid points (12 latitudes and 19 longitudes) for constant step size grid using the Clenshaw Curtis quadrature with standard deviation of 0.21 dB with the allowance to skip and interpolate measurements the at pole at  $\theta = 180^\circ$
- At least 266 unique measurement grid points (13 latitudes and 24 longitudes) for constant step size grid using the Clenshaw Curtis quadrature with standard deviation of 0.15 dB with the allowance to skip and interpolate measurements beyond  $150^\circ$  in  $\theta$

### 6.2 Beam Peak Search Measurement Grids

The beam peak search grid is used to determine the beam peak of the TX and RX beams.

For Power Class 3 devices with radiating apertures of less than or equal to 5 cm, i.e., non-sparse antenna arrays, either of the following measurement grids and implementations were found to be the best trade-off between measurement uncertainties, measurement grid points, and test time. Either of the two choices shall be used for this test plan:

- At least 800 measurement grid points for the constant density grid using the charged particle implementation
- At least 1106 measurement grid points (angular step size of  $7.5^\circ$ ) for the constant step size grid

The corresponding systematic error related to Beam Peak Search is 0.5 dB for the above choices.

### 6.3 Spherical Coverage Measurement Grids

The spherical coverage measurement grid is used to determine the CDF (CCDF) curve for EIRPs (EISs) measured on each grid point. For constant step size measurement grid types, the PDF contribution for each measurement point is scaled by the normalized Clenshaw-Curtis weights  $W(\theta)/W(\theta = 90^\circ)$  as

outlined in *CTIA 01.90* [9], Section 4.4.1, to account for the denser grid point distribution near the poles. When just a single measurement at the poles is performed, the PDF probability contributions need to be scaled by  $M * W(\theta) / W(\theta = 90^\circ)$  to account for the M longitudes at those two grid points. When using constant density grids, these corrections are not needed.

For Power Class 3 devices with radiating apertures of less than or equal to 5 cm, i.e., non-sparse antenna arrays, either of the following measurement grids and implementations were found to be the best trade-off between measurement uncertainties, measurement grid points, and test time. Either of the two choices shall be used for this test plan:

- At least 200 measurement points for the constant density grid using the charged particle implementation with a standard deviation of 0.11 dB
- At least 266 unique measurement grid points (angular step size of 15°) constant step size grid with a standard deviation of 0.12 dB

For EIS spherical coverage, an additional systematic error needs to be included in the measurement uncertainty budget that matches the DL power step size for the final EIS search.

The spherical coverage measurements can be performed without having to have the beam peak placed on a grid point, i.e., the beam peak does not need to be known prior to performing the spherical coverage test cases.

### 6.3.1 Clarification of Min EIRP/Max EIS at Target CDF/CCDF Value

When CDF/CCDF curves are generated based on spherical coverage measurement grids instead of beam peak search measurements grids, the number of non-zero PDF values could be very limited which causes the CDF curve to appear staggered. One sample, simulated CDF curve is shown in [Figure 6.3.1-1](#) for a coarse measurement grid.

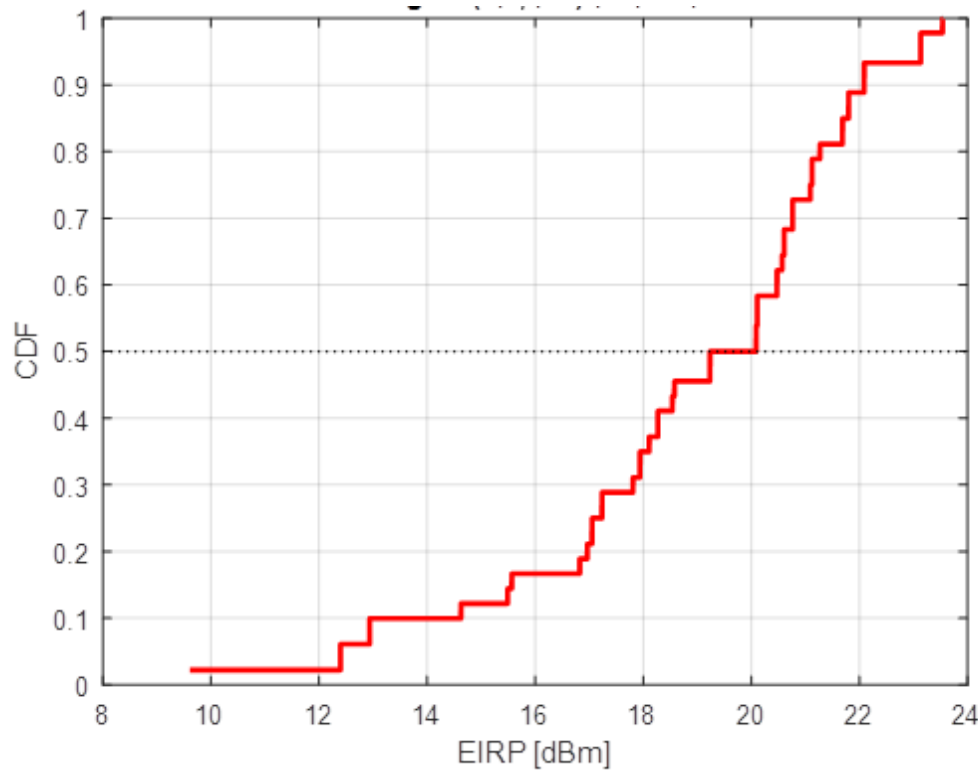

Figure 6.3.1-1 Sample CDF Curve for a Coarse Measurement Grid

While for very fine measurement grids, the definition of the min EIRP (max EIS) at the 50% CDF (CCDF),  $EIRP_{50\%-CDF}$  ( $EIS_{50\%-CCDF}$ ) is pretty clear since the CDF (CCDF) curve is smooth, the definition of the EIRP (EIS) value at the respective CDF (CCDF) target should be clarified for coarse grids with staggered CDF (CCDF) curves. Two scenarios are outlined in Figure 6.3.1-2 for EIRP; the concept can easily be applied to EIS. Figure 6.3.1-2 a shows the case where the CDF is not met with any EIRP value while in Figure 6.3.1-2 b, the target CDF is met with one (or more, as illustrated) EIRP values.

For the case shown in Figure 6.3.1-2 , min. EIRP at the target CDF shall be determined based on an interpolation of the CDF curve between the top of raising edges located right above the CDF target (blue circle) and right below the target (green circle).

For the case where the target CDF is met with one or more EIRP value(s), as illustrated in Figure 6.3.1-2 , min EIRP at the target CDF shall be determined as the min EIRP value that meets the CDF target.

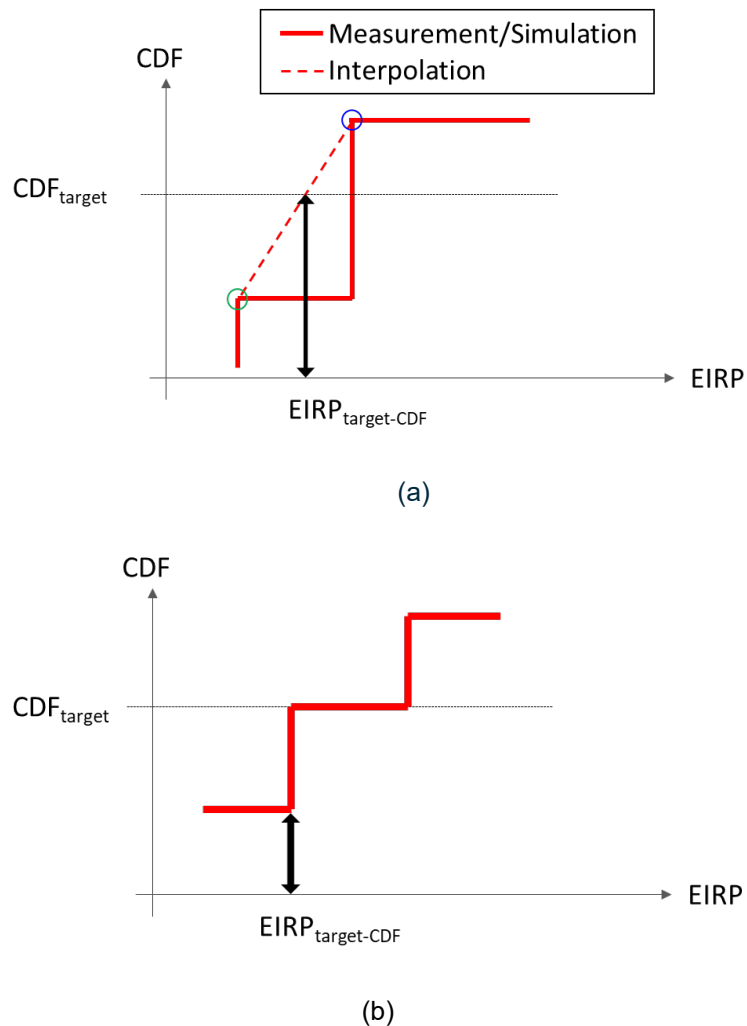

Figure 6.3.1-2 Illustration of CDF Scenarios, a) CDF Target is Not Met with any EIRP Value, b) CDF Target Is Met with One or More EIRP Values

It can be concluded that, for the case when the target CDF (CCDF) is not met with any EIRP (EIS) values, the min EIRP (max EIS) at the target CDF (CCDF) is determined based on an interpolation of the CDF (CCDF) curve between the raising edges located right above the CDF (CCDF) target and right below the target. For the case where the target CDF (CCDF) is met with one more or EIRP (EIS) values, define the min EIRP (max EIS) at the target CDF (CCDF) as the min EIRP (max EIS) value that meets the CDF (CCDF) target.

## Appendix A Revision History

Date	Version	Description
February 2022	4.0.0	Initial release. Changes compared to Version 1.0.2 <b>Section 5:</b> Revised test sequence order for TX test cases <b>Section 6:</b> Clarification of Clenshaw-Curtis weight usage at the poles
November 2022	4.0.1	<b>Section 6:</b> Corrected figure numbers to 6.3.1.1 and 6.3.1.2.