



Test Plan for Wireless Device Over-the-Air Performance

CTIA 01.40 Test Methodology, MIMO, Static Channel
Model, Multi-Probe Anechoic Chamber

Version 6.0.0

March 2023

© 2016- 2023 CTIA Certification. All Rights Reserved.

Any reproduction, modification, alteration, creation of a derivative work, or transmission of all or any part of this publication ("Test Plan"), in any form, by any means, whether electronic or mechanical, including photocopying, recording, or via any information storage and retrieval system, without the prior written permission of CTIA Certification, is unauthorized and strictly prohibited by federal copyright law. This Test Plan is solely for use within the CTIA Certification Program. Any other use of this Test Plan is strictly prohibited unless authorized by CTIA Certification or its assigns in writing.

Use Instructions

All testing shall be performed in a CTIA Certification Authorized Test Lab and shall be initiated through one of the following methods:

1. By submitting a PTCRB or IoT Network Certified device certification request at <https://certify.ptcrb.com/>
2. By submitting an OTA Test Plan use request at <https://certify.ctiacertification.org/>

CTIA Certification LLC
1400 16th Street, NW
Suite 600
Washington, DC 20036

1.202.785.0081

programs@ctiacertification.org

ctiacertification.org/test-plans/

Table of Contents

Section 1	Introduction	8
1.1	Purpose	8
1.2	Scope.....	8
1.3	MIMO OTA Test Overview	8
1.4	Over-the-Air Test System	8
1.4.1	Multi-Probe Anechoic Chamber (MPAC).....	8
1.5	Acronyms and Definitions	10
1.6	Referenced Documents	12
Section 2	MIMO Receiver Performance Assessment (Open-Loop Spatial Multiplexing).....	13
2.1	MPAC General Description	13
2.2	MPAC System Setup.....	13
2.2.1	MPAC Ripple Test	13
2.2.2	MPAC Calibration	13
2.2.2.1	Input Calibration.....	15
2.2.2.2	Output Calibration.....	18
2.2.2.3	Channel Emulator Input Phase Calibration	20
2.3	DUT Positioning within the MPAC Test Volume.....	22
2.3.1	Introduction	22
2.3.2	eNodeB Emulator Configuration.....	23
2.3.3	Channel Model Definition	26
2.3.4	Model Emulation of the Base Station Antenna Pattern	27
2.3.5	Signal to Interference Ratio (SIR) Control for MARSS Measurement.....	28
2.3.5.1	SIR Control for the MPAC Test Environment	28
2.3.5.2	SIR Validation within the MPAC Test Zone	28
2.3.5.3	Downlink Power Measurement Considerations.....	29
2.4	MIMO OTA Test Methodology.....	35
2.4.1	Introduction	35
2.4.2	SIR-Controlled Test Procedure Using the MPAC.....	35
2.4.3	MARSS Figure of Merit.....	36
Section 3	Common Uncertainty Contributions for MIMO Receiver Performance	38
3.1	Summary of Common Uncertainty Contributions for MIMO Receiver Performance.....	38
3.2	Summary of Common Uncertainty Terms for Path Loss Measurement.....	39
3.3	Combined and Expanded Uncertainties for Overall MIMO Receiver Performance	40
3.3.1	Compliance Criteria for the Overall MIMO Receiver Performance Uncertainty for MPAC	41
Section 4	Validation and Verification of Test Environments and Test Conditions.....	42
4.1	Measurement Instrument Overview.....	42
4.1.1	Measurement Instruments and Setup	42
4.1.2	Network Analyzer (VNA) Setup	42

4.1.3	Spectrum Analyzer (SA) Setup.....	43
4.1.4	Signal Analyzer (SAN) Setup	43
4.2	Validation of the MPAC MIMO OTA Test Environment and Test Conditions.....	44
4.2.1	Validation of SIR-Controlled MPAC Test Environment	44
4.2.1.1	Validation of MPAC Power Delay Profile (PDP)	44
4.2.1.2	Power Delay Profile Result Analysis	45
4.2.1.3	Measurement Antenna	45
4.2.1.4	Pass/Fail Criteria	46
4.2.2	Validation of Doppler/Temporal Correlation for MPAC.....	46
4.2.2.1	MPAC Doppler/Temporal Correlation Method of Measurement	46
4.2.2.2	MPAC Doppler/Temporal Correlation Measurement Antenna	49
4.2.3	Validation of MPAC Spatial Correlation.....	49
4.2.3.1	MPAC Spatial Correlation Method of Measurement	50
4.2.3.2	Validation of MPAC Spatial Correlation Using Time Domain Techniques	51
4.2.3.3	MPAC Spatial Correlation Measurement Results Analysis	52
4.2.3.4	MPAC Spatial Correlation Measurement Results Analysis using time domain technique	53
4.2.3.5	MPAC Spatial Correlation Measurement Antenna	54
4.2.4	Validation of Cross-Polarization for MPAC.....	54
4.2.4.1	MPAC Cross Polarization Method of Measurement.....	54
4.2.4.2	MPAC Cross Polarization Measurement Procedure	54
4.2.4.3	Cross Polarization Expected Measurement Results	55
4.2.5	Input Phase Calibration Validation (Normative)	55
Section 5	Test Zone Dimension Definitions.....	56
5.1	Test Zone Dimension Definitions for Normative Bands.....	56
5.2	Test Zone Dimension Definitions for Optional Bands.....	57
Section 6	Variable RMC MIMO Throughput Test (Informative).....	59
6.1	Test Procedure	59
Appendix A	Revision History	60

List of Figures

Figure 1.4.1-1 Block Diagram of a Typical Boundary Array RF Environment Simulation System	9
Figure 2.2.2-1 Typical Downlink MIMO Boundary Array System Configuration with Multiple Channel Emulators and Output Amplifiers.....	14
Figure 2.2.2-2 Typical Single-Downlink Path from the Communications Tester to the DUT in the Center of the Test Volume	14
Figure 2.2.2.1-1 Typical Input Calibration Setup to Balance Input Reference Levels using a Single CW Source	16
Figure 2.2.2.1-2 Typical Input Calibration Setup to Balance Input Reference Levels using a Dual CW Source	16
Figure 2.2.2.1-3 Example of Using the Channel Emulator Power Meter to Obtain a Reference for Determining Net Path Loss of Each Input Path.....	17
Figure 2.2.2.2-1 Illustration of a Single Path from the Communication Tester to the Center of the Test Volume	18
Figure 2.2.2.2-2 Typical Configuration where the End-To-End Path Loss Can Be Separated Into The External Loss (Gain) Components and the Internal Loss (Gain) Components Defined by the Channel Model and Other Channel Emulator Settings	19
Figure 2.2.2.3-1 Sample Input Phase Calibration using a Spectrum Analyzer to Monitor the Output as a Phase Offset Is Applied to One Input of the Channel Emulator	21
Figure 2.2.2.3-2 Result of Applying a Fixed -52° Offset Correction to the Channel Emulator Input Due to the Null Found at 232°	22
Figure 2.3.4-1 “X” Antenna Gain Assumption (a) Linear Gain (b) dB	28
Figure 2.3.5.2-1 Typical Setup for Verifying SIR Level in the Anechoic Chamber Multi-Probe MIMO OTA Test System.....	29
Figure 2.3.5.3-1 TD-LTE Frame Configuration Showing Special Subframes 1 and 6, Uplink in Subframes 2, 3, 7, & 8, and Unused Subframe 5	31
Figure 2.3.5.3-2 Swept Frequency Response of TD-LTE Signal Showing Frequency and Time Dependence	31
Figure 2.3.5.3-3 Swept Frequency Response of TD-LTE Signal With Multiple Trigger Offsets	32
Figure 2.3.5.3-4 Average Of Remaining TDD Downlink Signal After Removal of Uplink and Unused Segments	32
Figure 2.3.5.3-5 Fourier Spectrogram of TD-LTE Subframes Illustrating the Portion of the Downlink Signal to be Integrated Bordered in Red	33
Figure 4.1.2-1 Setup for Anechoic Chamber VNA Measurements	43
Figure 4.1.3-1 Setup for Spectrum Analyzer Measurements.....	43

Figure 4.1.4-1 Setup for Signal Analyzer Measurements	44
Figure 4.2.2.1-1 Reference Temporal Correlation Limits for SCME Urban Macro Plotted from Table A.2.2.1-4	49
Figure 4.2.3.1-1 Test Antenna Positions	50
Figure 4.2.3.3-1 MPAC Reference Spatial Correlation Function for SCME Urban Macro plotted from Table A.2.3.1-3	53

List of Tables

Table 2.3.2-1 eNodeB Configuration Parameters for FDD Open-Loop Spatial Multiplexing (TM3, Rank 2) Tests Employing SIR Control	23
Table 2.3.2-2 eNodeB Configuration Parameters for TDD Open-Loop Spatial Multiplexing (TM3, Rank 2) Tests Employing SIR Control	25
Table 2.3.3-1 SCME Urban Macro-Cell Channel Model (UMa)	27
Table 2.3.5.3-1 Spectrum Analyzer Settings for SIR Control Verification Using Integrated Channel Power	35
Table 3.1-1 Common Uncertainty Contributions for MIMO DUT Receiver Performance Measurement ...	38
Table 3.1-2 Common Uncertainty Contributions for MIMO Path Loss Measurement	39
Table 3.3.1-1 Expanded Uncertainty Maximum Limit for MIMO Receiver Performance	41
Table 4.1.1-1 Required Measurement Equipment	42
Table 4.2.1.1-1 MPAC PDP VNA Settings	44
Table 4.2.1.1-2 MPAC PDP Channel Model Specification	44
Table 4.2.1.4-1 SCME Urban Macro Target Values	46
Table 4.2.2.1-1 MPAC Doppler/Temporal Correlation Signal Generator Settings	46
Table 4.2.2.1-2 MPAC Doppler/Temporal Correlation Spectrum Analyzer Settings	46
Table 4.2.2.1-3 Doppler Channel Model Specification	47
Table 4.2.2.1-4 MPAC Reference Temporal Correlation Limits for SCME Urban Macro	47
Table 4.2.3.1-1 MPAC Spatial Correlation VNA Settings	50
Table 4.2.3.1-2 MPAC Spatial Correlation Channel Model Specification	51
Table 4.2.3.2-1 MPAC Spatial Correlation Channel Model Specification	51
Table 4.2.3.2-2 MPAC Spatial Correlation Signal Generator Settings	51

Table 4.2.3.2-3 MPAC Spatial Correlation Signal Analyzer Settings	51
Table 4.2.3.3-1 MPAC Reference Spatial Correlation Function for SCME Urban Macro	52
Table 4.2.4.1-1 MPAC Cross-Polarization VNA Settings	54
Table 4.2.4.1-2 MPAC Cross-Polarization Channel Model Specification	54
Table 5.1-1 Test Zone Dimension Definition for Normative FDD Bands of Operation	56
Table 5.1-2 Test Zone Dimension Definition for Normative TDD Bands of Operation	56
Table 5.2-1 Test Zone Dimension Definition for Optional FDD Bands of Operation	57
Table 5.2-2 Test Zone Dimension Definition for Optional TDD Bands of Operation	58

Section 1 Introduction

1.1 Purpose

The purpose of this document is to define the CTIA Certification program test methodology for radiated performance measurements of LTE 2x2 downlink MIMO wireless devices. Future revisions of this test plan may also include methodologies for assessing radiated performance during non-MIMO operation using transmit diversity.

1.2 Scope

This test plan defines general requirements for test systems, test conditions, equipment configurations, laboratory techniques, test methodologies, and evaluation criteria that must be met in order to ensure the accurate, repeatable, and uniform testing of wireless devices capable of supporting LTE 2x2 downlink MIMO. Future revisions of this document may include the equipment configurations, test methodologies, and evaluation criteria required to assess the DUT's transmit diversity performance.

This test plan provides high level test procedures and basic test equipment configuration information but does not include detailed test instructions by which to execute certification testing. Such documentation and procedures must be presented by the CTIA Authorized Test Lab (ATL) as part of the CTIA authorization process and subsequently employed and maintained by the ATL to remain authorized to perform certification testing.

1.3 MIMO OTA Test Overview

The scope and overview of the MIMO OTA Test Plan is outlined in Section 1.3 and specifically in Section 1.3.3 of *CTIA 01.01* [1].

1.4 Over-the-Air Test System

The tests described in this document require a test system capable of creating reproducible multi-path over-the-air propagation channels meeting all specifications of the required spatial channel models. In this test plan, the test system currently specified is capable of producing the required test conditions for all of the required test cases listed in the following sections, with certain limitations associated with the UE antenna spacing as described in Section 2.3.3. Calibration and validation methodologies are provided as well.

1.4.1 Multi-Probe Anechoic Chamber (MPAC)

The Multi-Probe Anechoic Chamber is based on the anechoic boundary array concept. The anechoic boundary array refers to a mechanism by which any desired near-field RF environment can be created, subject to the limitations imposed by the resolution of the boundary array and the channel emulation applied. By arranging an array of antennas around the Device Under Test (DUT), a spatial distribution of angles of arrival may be simulated to expose the DUT to a near field environment that appears to have originated from a complex multipath far field environment. The anechoic chamber only serves to isolate the test volume from the external laboratory environment and to minimize unwanted internal reflections in the region of the DUT. It is assumed to play no part in the environment generated.

Signals propagate from the base station/communication tester to the DUT through a simulated multipath environment known as a spatial channel model, where appropriate channel impairments such as Doppler and fading are applied to each path prior to injecting all of the directional signals into the chamber simultaneously through the boundary array. The resulting field distribution in the test volume is then integrated by the DUT antenna(s) and processed by the receiver(s) just as it would do so in any non-simulated multipath environment.

The uniformly spaced array resolution required to precisely reproduce any possible environment for a given DUT antenna separation is based on common Nyquist theorem, requiring two samples per wavelength on the circumference of a sphere enclosing antennas. However, the actual resolution required to adequately reproduce a given spatial channel model is dependent on the model itself, since most environments are not spatially uniform. Thus, there are directions where little or no signal is received and therefore it is possible to asymmetrically optimize the antenna distribution to increase the resolution while limiting the number of emulated channels required.

For the purposes of this test plan and the standard multi-cluster spatial channel models used to evaluate the DUT, a boundary array distributed as an azimuthal ring about the DUT is considered sufficient to adequately reproduce the target channel models. The minimum resolution of such an array consists of eight dual-polarized elements spaced every 45° around the DUT in the X-Y plane as defined in Table A.1 1 of *CTIA 01.71* [2]. Arrays with higher resolution (e.g. closer probe spacing), using uniform, or model-specific non-uniform antenna distributions may be used provided the resulting system configuration passes the required channel model and site validation tests, specified in Section 4.2. Any theoretical references for channel model and site validation for the higher array resolutions or non-uniform antenna distributions will continue to use the existing validation tests in Section 4.2 and any further extension of the validation tests is out of the scope of this test plan.

Figure 1.4.1-1 illustrates a typical eight element boundary array configuration with 16 channels of spatial channel emulation. Each output channel of the channel emulator typically requires amplification to provide enough signal level to propagate over the air to the DUT. For tests requiring uniform spatial interference, uncorrelated noise is injected uniformly distributed in azimuth around the DUT. While this is typically injected at the output of the channel emulation, independent mechanisms that produce the required uniform interference may be used. For example, systems with non-uniform distributions of the boundary array (distributed to match the cluster(s) of the model being used) may choose to use a uniform array of antennas to inject the interference.

A turntable is normally used to provide azimuthal averaging of the device orientation within the test volume, although rotation of the channel model can also be used to accomplish a similar result, depending on the desired angular resolution. Rotation of the device within the test volume provides for determining a statistical average performance of the device in the specified spatial channel, as opposed to measuring a radiation pattern of the DUT.

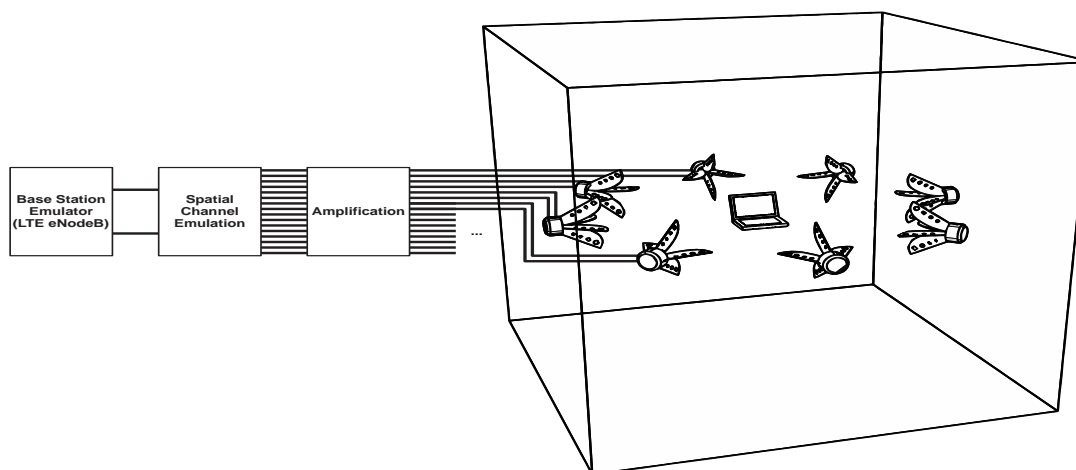

Figure 1.4.1-1 Block Diagram of a Typical Boundary Array RF Environment Simulation System

1.5 Acronyms and Definitions

The following specialized terms and acronyms are used throughout this document.

Acronym/Term	Definition
AS	Angular Spectrum
ATL	Authorized Test Lab
AoA	Angle of Arrival
AoD	Angle of Departure
AWGN	Additive White Gaussian Noise
BS	Base Station
CE	Channel Emulator
CIR	Channel Impulse Response
CW	Continuous Wave
DML	Data Mode-Landscape
DMP	Data Mode-Portrait
DMSU	Data Mode Screen Up
DTX	Discontinuous Transmission
DUT	Device Under Test
FS	Free Space
FDD	Frequency Division Duplexing
HARQ	Hybrid Automatic Repeat ReQuest
LTE	Long Term Evolution
PAS	Power Angular Spectrum
PDSCH	Physical Downlink Shared Channel
PDP	Power Delay Profile
MARSS	MIMO Average Radiated SIR Sensitivity
MIMO	Multiple Input Multiple Output
Measurement Points	The individual data points collected during execution of the requisite test methodology.
MPAC	Multi-Probe Anechoic Chamber utilized for the assessment of MIMO-capable devices.

Acronym/Term	Definition
OCNG	Orthogonal Channel Noise Generation
OTA	Over The Air
PDSCH-EPRE	Packet Downlink Shared Channel-Energy Per Resource Element
RB	Resource Block
RS-EPRE	Reference Signal-Energy Per Resource Element
RX	Receive
SA	Spectrum Analyzer
SAN	Signal Analyzer
SCME	Spatial Channel Model Extension
SINR	Signal to Interference & Noise Ratio
SIR	Signal to Interference Ratio
TBS	Transport Block Size
TDD	Time Division Duplexing
Test Condition	The emulated propagation conditions utilized within the test system. In this version of this test specification, the SCME UMa channel model is the only valid test condition. The test condition is only seen in the validated test volume of the test system.
Test System	The controlled propagation environment used for evaluation of the Device Under Test (DUT). In the context of this version of this test plan, the Multi Probe Anechoic Chamber (MPAC) and Radiated Two-Stage (RTS) are the only valid test systems.
Test Methodology	The process used to execute tests against the DUT using the Test System(s) and Test Condition(s) specified by this document.
Test Volume	The useable volume within the test system in which the DUT can be placed. The test volume is assumed to have a uniform power distribution within the uncertainty specified by the site validation.
Test Zone	The portion of the test volume in which the test condition criteria are met within the applicable uncertainty limits.
TX	Transmit
UMa	Urban Macro
VNA	Vector Network Analyzer
XPR	Cross Polarization Ratio

1.6 Referenced Documents

The following documents are referenced in or applicable to this test plan.

Document Number, Document Name	
[1]	CTIA 01.01 <i>Test Scope, Requirements, and Applicability</i>
[2]	CTIA 01.71, <i>Positioning Guidelines</i>
[3]	CTIA 01.20, <i>Test Methodology, SISO, Anechoic Chamber</i>
[4]	CTIA 01.73, <i>Ancillary Procedures</i>
[5]	3GPP TS 36.508, <i>Evolved Universal Terrestrial Radio Access (E-UTRA) and Evolved Packet Core (EPC); Common test environments for User Equipment (UE) conformance testing</i>
[6]	CTIA 01.50, <i>Wireless Technology, 3GPP Radio Access Technologies</i>
[7]	3GPP TS 36.521-1, <i>Evolved Universal Terrestrial Radio Access (E-UTRA); User Equipment (UE) conformance specification; Radio transmission and reception; Part 1: Conformance testing</i>
[8]	3GPP TS 36.213, <i>Evolved Universal Terrestrial Radio Access (E-UTRA); Physical layer procedures</i>
[9]	3GPP TR 37.977, <i>Universal Terrestrial Radio Access (UTRA) and Evolved Universal Terrestrial Radio Access (E-UTRA); Verification of radiated multi-antenna reception performance of User Equipment (UE)</i>
[10]	CTIA 01.70, <i>Measurement Uncertainty</i>
[11]	3GPP TR 37.901
[12]	CTIA 01.03, <i>Normative Reporting Tables</i>
[13]	B. Yanakiev, J. Nielsen, M. Christensen, G. Pedersen: <i>Antennas in Real Environments</i> , EuCAP 2011
[14]	Baum, D.S.; Hansen, J.; Salo, J., <i>An interim channel model for beyond-3G systems: extending the 3GPP spatial channel model (SCM)</i> , Vehicular Technology Conference, 2005. VTC 2005-Spring. 2005 IEEE 61st , vol.5, pp.3132-3136
[15]	<i>Guide to the expression of uncertainty in measurement</i> , Genève, Switzerland, International Organization for Standardization, 1995
[16]	IEEE.149-1979.R2008: <i>IEEE Standard Test Procedures for Antennas</i> , IEEE, December 2008
[17]	TR 102 273, <i>Electromagnetic compatibility and Radio spectrum Matters (ERM); Improvement on Radiated Methods of Measurement (using test site) and evaluation of the corresponding measurement uncertainties; Part 1: Uncertainties in the measurement of mobile radio equipment characteristics; Sub-part 2: Examples and annexes</i>

Section 2 MIMO Receiver Performance Assessment (Open-Loop Spatial Multiplexing)

2.1 MPAC General Description

The tests in this section assess the DUT's MIMO OTA throughput performance when the serving eNodeB is utilizing Open-Loop Spatial Multiplexing (OL-SM). During execution of OL-SM tests, the DUT shall be illuminated with an average RS-EPRE that is maintained constant while the on-channel AWGN interferer is varied. All OL-SM tests shall be executed in the MPAC where the spatial and temporal characteristics of the SCME channel may be emulated and controlled.

2.2 MPAC System Setup

This test procedure currently assumes the use of a multi probe anechoic chamber (MPAC) test system for generation of the desired test conditions. In addition to qualifying the implementation of the channel model to be used as specified in Section 4.2, each system installation shall be calibrated and validated to ensure proper operation.

2.2.1 MPAC Ripple Test

For an azimuthal boundary array, the standard phi-axis ripple test described in Section 5 of *CTIA 01.73* [4] shall be used. Since the boundary array is arranged in an azimuthal orientation about the device and labs are not expected to have a theta-axis positioner available, the results of a phi-axis ripple test using both a dipole and loop are considered sufficient to evaluate the test volume. As in *CTIA 01.73* [4], the test covers a cylindrical quiet zone 300 mm in diameter around the phi axis and 300 mm tall. The Notebook PC sized test volume is not required to be measured. The tests shall be performed at the frequencies outlined in Section 3 of *CTIA 01.73* [4].

2.2.2 MPAC Calibration

Calibration of the MPAC boundary array system is quite similar to the range reference measurement described in Section 4 of *CTIA 01.73* [4], where each polarized element of the boundary array adds an additional path loss measurement to the two polarizations normally calibrated for a SISO antenna pattern measurement system (see [Figure 2.2.2-1](#)). However, unlike traditional TRP/TIS testing where the path loss corrections can all be applied as a post processing step to the measured data, the path loss for each element in the boundary array must be balanced at test time in order to produce the desired field distribution within the test volume. Since all elements are active simultaneously, any relative differences in path loss for different elements would result in an alteration of the angular dependence of the channel model being injected into the chamber.

With the introduction of channel emulation to the system, the path loss from the communication tester to the center of the test volume is split between the cables and components connecting the communication tester output(s) to the channel emulator input(s) and those from the channel emulator outputs to the center of the test volume. This split in the signal path requires a split in the calibration process in order to determine relative offsets in both the input and output components of the system.

For the purposes of calibration of these external components, the channel emulator can be thought of as a variable gain stage (e.g. variable attenuator) with level adjustments at both inputs and outputs as well as an internal loss component associated with the chosen channel model. The ability to selectively enable specific inputs and outputs allow it to be used as a splitter/switch combination to enable specific signal paths for calibration.

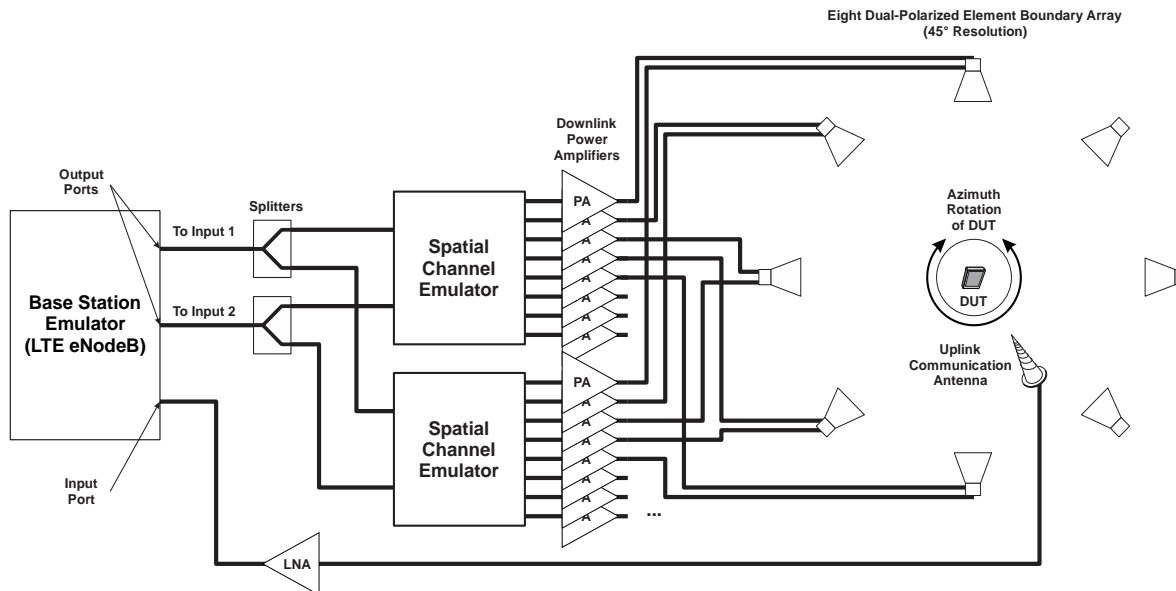

Figure 2.2.2-1 Typical Downlink MIMO Boundary Array System Configuration with Multiple Channel Emulators and Output Amplifiers

Figure 2.2.2-2 illustrates a single path from the base station emulator/communication tester to the center of the test volume. A typical system implementation will likely have various signal routing options to connect to different communication testers and different antenna configurations, as well as allowing the bypass of various components in the system for calibration or other testing purposes. The various gains and losses of all system components shall be accounted for in the range calibration, along with the associated measurement uncertainties.

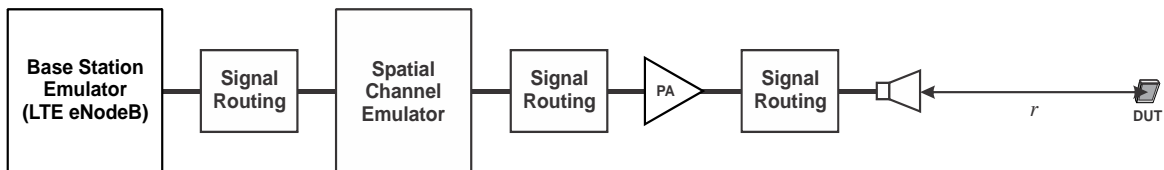

Figure 2.2.2-2 Typical Single-Downlink Path from the Communications Tester to the DUT in the Center of the Test Volume

While traditional sensitivity measurements like those used in TIS testing only require one absolute power reference at the communication tester, the addition of signal to interference ratio (SIR) based testing requires a second power reference at the interferer source. A typical approach for introducing interference is to inject the noise at each output of the channel emulator, thus requiring the determination of the difference in path losses between the communication tester output and channel emulator output, in addition to the net path loss from the communication tester to the center of the test volume. For systems utilizing completely independent noise sources, the path loss from that noise source to the center of the test volume must be determined independently.

The test frequencies to be used when calibrating the MPAC boundary array shall correspond to the frequency of the downlink for mid-range from 3GPP TS 36.508 [5] as required per band for the normative bands defined in Table 2.3.2-1 and Table 2.3.2-2

2.2.2.1 Input Calibration

The primary goal of the input calibration is to balance the input levels at the channel emulator such that the outputs of the communication tester arrive at the inputs to the channel emulator with the same magnitude and phase relationship with which they were generated. Depending on the implementation, it may also be necessary to determine the net path loss between the communication tester and channel emulator in order to apply that as a separate correction, usually for SIR based testing.

Currently available channel emulators have integrated power measurement functions that can be used to evaluate the power level at each input. While this function can typically be used to automatically balance the inputs to the average power measured, this introduces a number of problems if modulated wireless signals are used. The downlink signal generated by an LTE communication tester prior to establishing a connection to the DUT does not generally have the same occupied bandwidth as the downlink signal used for the sensitivity test, so the average power measured will be different. In addition, the average broadband power measured for the specified test signal does not exactly reflect the required RS-EPRE setting due to the unoccupied subframes in the reference measurement channel. For this reason, the preferred approach is to use a CW signal to determine the path loss of each of the paths and use the resulting information to set the reference levels used for output calibrations and device testing. Note, however, that any changes to the input reference level of the channel emulator alter the net path loss of the system, so any function that automatically measures the power and adjusts the reference level must be accounted for in the total path loss corrections.

[Figure 2.2.2.1-1](#) shows a typical setup for calibrating the relative input levels of each channel emulator input from the same CW source. A stable CW source (e.g. signal generator or VNA in zero span mode) is used to inject a constant signal level into each cable that would normally connect to the MIMO channel outputs of the communication tester. A fixed attenuator at the end of the source cable minimizes the measurement uncertainty contribution due to changes in standing wave contributions for the various paths. Alternately, the communication tester may be used as the CW source as shown in [Figure 2.2.2.1-2](#) if it supports that option. Since the same communication tester is used during the calibration and DUT measurement, any standing wave contribution from the cables as well as any internal offsets in the communication tester outputs are included in the relative offsets determined by the input calibration.

By using a direct connection to one of the channel emulator ports, as shown in [Figure 2.2.2.1-3](#), the reference power level at the input to the cables can be determined in order to calculate the path loss of each input path in addition to the relative offsets between them. In this way, the measurement uncertainty for the path loss of the cables is based primarily on the linearity of the channel emulator power meter. For the case of using the communication tester as a dual CW signal source, the net path losses of the cables cannot be directly determined since a second power reference point is not being measured at the other end of the cable. However, with the assumption that turning modulation on or off on the tester does not alter the absolute power level of the signal (or that appropriate compensation is applied) setting the channel emulator input reference level to the measured power level has the effect of correcting for the input cable loss such that any applied signal-to-noise ratio at the channel emulator outputs will have the proper relative noise level. Note, however, that if the automatic measurement function of the channel emulator is used on a CW signal, the crest factor setting must be adjusted to address the effect of the applied modulation for DUT testing and avoid overdriving the inputs. The effect of this adjustment must also be accounted for in the total path loss correction.

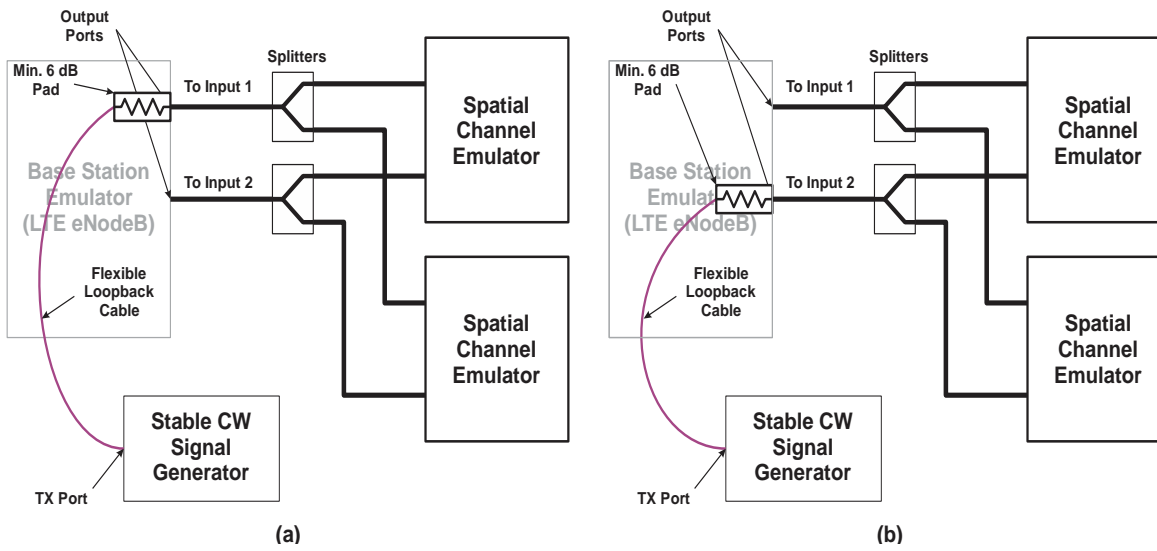

Figure 2.2.2.1-1 Typical Input Calibration Setup to Balance Input Reference Levels using a Single CW Source

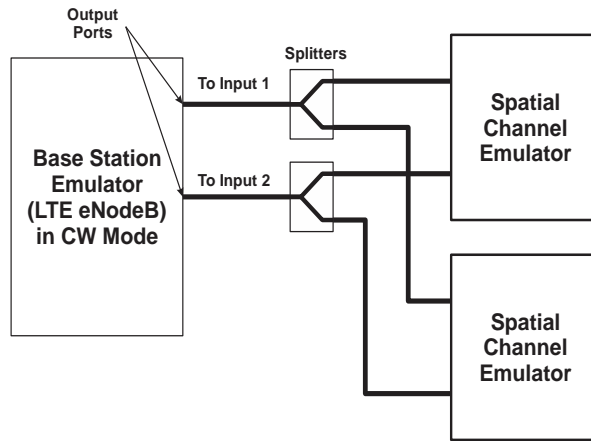

Figure 2.2.2.1-2 Typical Input Calibration Setup to Balance Input Reference Levels using a Dual CW Source

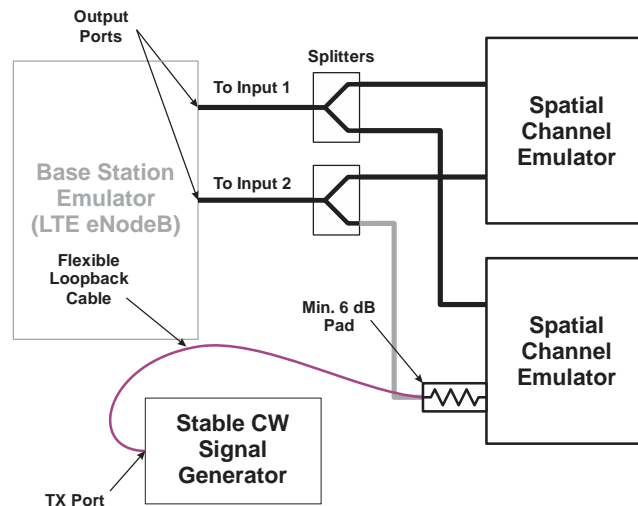

Figure 2.2.2.1-3 Example of Using the Channel Emulator Power Meter to Obtain a Reference for Determining Net Path Loss of Each Input Path

The following list describes a typical process for determining the relative and absolute input path losses using a single CW source.

1. Connect an isolation attenuator (minimum 6 dB recommended) to the end of an RF cable attached to a stable CW signal generator.
2. Attach the attenuated end of the cable to the end of the system cable that normally connects to the first output of the communication tester.
3. Set the signal generator and channel emulators to the frequency to be measured. Alternately, multiple frequencies may be calibrated for a single center frequency setting of the channel emulator (CE), provided the same center frequency setting of the CE is used for subsequent tests of the same frequency range(s).
4. For the corresponding input of each channel emulator, measure the received power, ensuring that the power is at or below the reference level setting of the channel emulator in order to avoid overdriving, but close enough to remain in the linearity region of the input.
5. Repeat steps 3 and 4 for each frequency to be calibrated.
6. For each subsequent input cable (communication tester output connection), move the end of the signal source cable to the corresponding input cable and repeat steps 3 through 5.
7. If it is necessary to determine net path loss of each cable in each frequency band of interest, measure the power at the attenuated end of the signal source cable, ideally using a direct connection to one of the inputs of the channel emulator, applying the same considerations used in steps 3 and 4 above.
8. Compute the relative difference between the highest power measured across all inputs and the rest of the inputs. This offset is then applied to the reference level for each input for all subsequent tests to bring all digitized inputs to the same level.
9. Alternately, determine the average power level of each output of the communication tester and subtract the path loss to each input port to set the corresponding reference level.
10. To obtain the target reference levels using the communication tester in CW mode instead of a single CW source, attach the communication tester as it will be used for device testing and repeat steps 3 to 4 for each input of the channel emulator. The measured levels are then used to set the required reference level for the corresponding communication tester output power settings. In the event that specific implementation details differ from these steps, proper documentation shall be generated describing the method to be employed.

2.2.2.2 Output Calibration

The primary goal of the output calibration is to balance the outputs of the channel emulator to compensate for the differences in path loss to the center of the test volume. Thus, for SIR testing, only the relative path losses between each output, as well as any relative losses between signal source and interference source, are required to sufficiently calibrate the system. The net path loss of the calibrated system is only required for throughput vs. power testing and is useful for ensuring that the signal is sufficiently above the platform noise to obtain the desired SIR. However, if a suitable calibrated reference antenna is used during the output calibration, then the necessary end-to-end path loss correction can also be extracted from the same set of measured data. Otherwise, once the relative corrections have been applied to the outputs, a separate path loss measurement can be performed on any one of the individual paths to determine the net path loss, since all of the relative errors are compensated separately.

Figure 2.2.2.2-1 illustrates a single path from the communication tester to the center of the test volume. While the channel emulation and other components are part of the signal path, the definition of the total path loss from the communication tester to the center of the test volume remains the same as that for the OTA test plan. Thus, the mechanisms for measuring the end-to-end loss are the same. Since the channel model and other input and output level setting controls of the channel emulator will alter the net path loss, the components can be separated into the internal gain or loss of the channel emulator and the external gain or loss of all of the other system components, as shown in Figure 2.2.2.2-2. By measuring the end-to-end loss and subtracting the internal loss term, the resulting external loss corrections can be combined with any other channel emulator settings to determine the signal levels in the test volume. For isolated signal paths that are not altered between the calibration step and the DUT measurement step (e.g., between the channel emulator and amplifier or amplifier and antenna) any standing wave contributions from these components can be assumed to be corrected by the range calibration. The calibration also embeds any residual offsets from the inputs and outputs of the channel emulator into the net path loss that is measured.

Alternatively, subsets of these paths may be measured independently, and the total path gain/loss of each component combined, minus the loss terms of any additional cables, switches, or other accessories used during the calibration process that are not part of the test signal path.

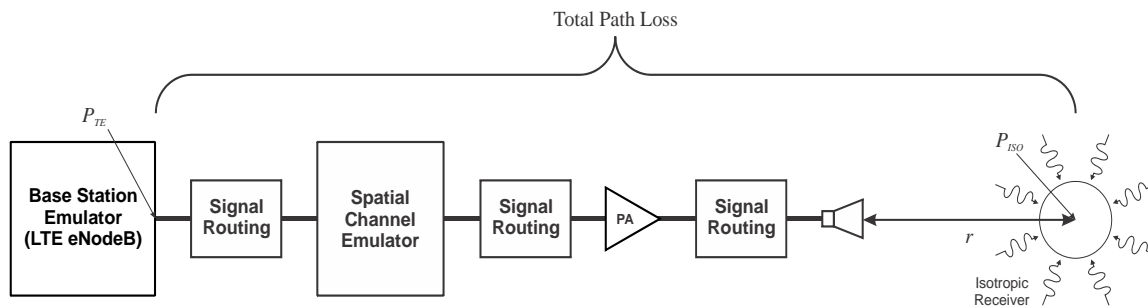

Figure 2.2.2.2-1 Illustration of a Single Path from the Communication Tester to the Center of the Test Volume

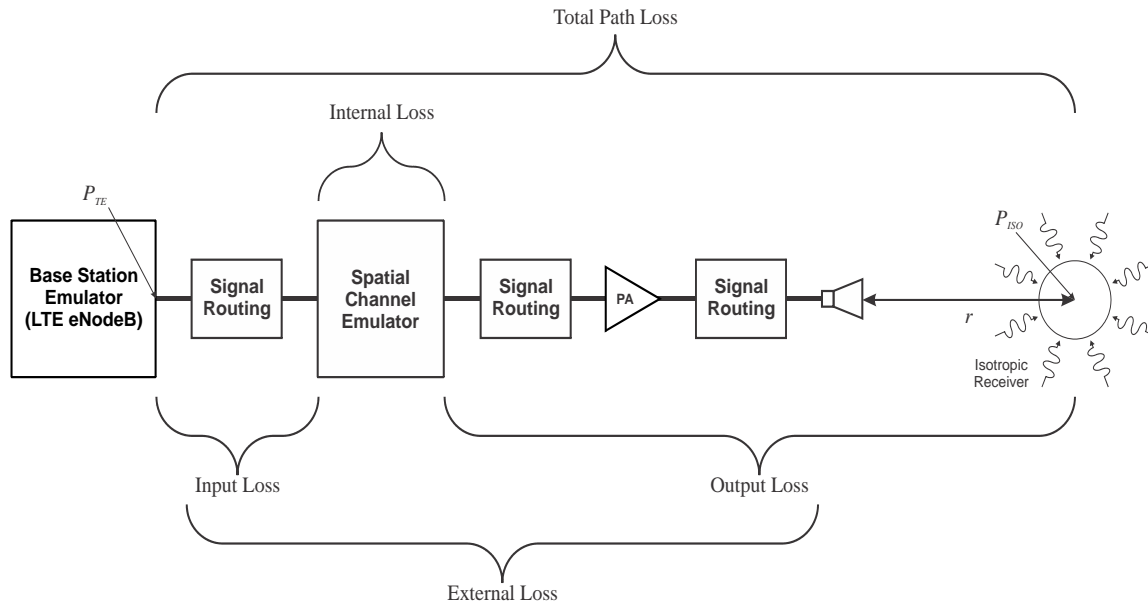

Figure 2.2.2.2-2 Typical Configuration where the End-To-End Path Loss Can Be Separated Into The External Loss (Gain) Components and the Internal Loss (Gain) Components Defined by the Channel Model and Other Channel Emulator Settings

The following list describes a typical process for determining the relative and absolute input path losses from the communication tester to the center of the test volume. The procedure below is based on the range calibration procedure described in *CTIA 01.73* [4] and can be adapted for multiple step calibrations where different segments of the path loss are measured independently, and the individual losses and corresponding uncertainties are combined to obtain the total path loss for each measurement path.

1. Configure and perform a cable calibration of the VNA or signal generator/receiver combination to be used for the range calibration as described in *CTIA 01.73* [4]. Since this is a downlink direction calibration, the receiver or the receive port will be connected to the reference antenna cable and the loopback cable will attach to the transmit port (typically this is the same cable and attenuator used for the input calibration step in the previous section).
2. Following the guidance of steps 1 through 4 in section 2.4.3 of *CTIA 01.73* [4], attach the attenuated end of the transmit cable to the end of the system cable that normally connects to the first output of the communication tester. (Note the choice of input cable is arbitrary so long as only one input is enabled on each channel emulator.)
3. Set the signal generator and channel emulators to the frequency to be measured. Alternately, multiple frequencies may be calibrated for a single center frequency setting of the CE, provided the same center frequency setting of the CE is used for subsequent tests of the same frequency range(s). At each frequency, apply the relative offsets determined from the input calibration to the reference level setting of the channel emulator to correct for any relative input path loss. Ensure that the power into the channel emulator is at or below the reference level setting of the channel emulator in order to avoid overdriving, but close enough to remain in the linearity region of the input.
4. Set the output level of each used port of the channel emulator to the maximum level supported for each frequency to be tested, being sure to remain in the linear region of any external amplification to the test volume.

5. Use a static constant tap (straight through) channel model to produce a direct connection from the input to the output of the channel emulator.
6. Iterate through each output port of the channel emulator, enabling only one path from the input cable to the center of the test volume at a time, and ensuring that the reference antenna is oriented at bore sight to the direction and polarization of the active array element.
7. Measure the total path loss following the guidance of Section 2.4.2 of *CTIA 01.73* [4] for each frequency of interest.
8. Repeat steps 3 through 7 for each frequency and output path to be calibrated. The order of iteration through frequencies and outputs can be interchanged as necessary for speed or ease of operation.
9. Compute the relative difference between the worst path loss and all other paths at each frequency. These offsets are then applied to the output power setting for each corresponding output to create the same net path loss between the channel emulator and the center of the test volume for each output path. Since the signal generators of the CE can never go above maximum output, the outputs of the paths with lower losses must be reduced to correspond to the path with the highest path loss.
10. The loss for the worst-case path, corrected for the channel model and number of active inputs and outputs (the internal gain of the CE) then becomes the reference path loss of the entire system. This loss is used to compute the power in the test volume relative to the output power of the communication tester.
11. After applying the relative offsets to each output, it is recommended to perform a spot check of the residual relative error, determined by repeating the calibration process with offsets applied. This provides a validation of the calibration process and an estimate of the residual error due to the total path loss and non-linearities in the system components. In the event specific implementation details differ from this procedure, proper documentation shall be generated describing the appropriate process.

2.2.2.3 Channel Emulator Input Phase Calibration

The use of highly correlated channel models such as the SCME UMa model introduces a unique set of problems. One is the phase relationship between the LTE streams from the base station. While the average power doesn't vary as a function of the input phase in the test volume of the MPAC, the LTE MIMO receiver is capable of detecting a difference that can result in a shift of the DUT measured performances. The effect is a variation of the throughput up and down when a constant average power is at the DUT. The maximum throughput performances are seen when the base station LTE signals are in-phase or 180 degrees out-of-phase with minimums at ± 90 degrees. Thus, it is necessary to ensure that the relative phase between the two communication tester outputs as applied to the digital channel model inputs is zero. However, since the phase relationship of the communication tester signal generators and the channel emulator receivers cannot be guaranteed, it is not possible to simply correct for the phase differences of the input cables. Instead, the system shall be calibrated and corrected for the input phase offsets just prior to the start of the test, since any changes in frequency or other related settings may change the phase relationship of the outputs and inputs. For communication testers that are unable to maintain a constant phase relationship between the outputs when signaling is disabled, care shall be taken to ensure that the communication tester downlink signal remains enabled throughout the entire test.

Several methods have been developed to perform the phase calibration. The simplest involves configuring the communication tester to output the same signal on both outputs. This can be a CW (modulation disabled) provided that the modulation can be re-enabled and the device test performed without changing the phase relationship of the outputs. It can also be accomplished with a modulated signal using an output H-matrix operation or other test feature capable of outputting a single stream on both outputs. The calibration can be performed using external equipment (e.g. a spectrum analyzer) to

monitor the output power of the channel emulator in a straight-through (constant tap) scenario while the phase offset of one of the inputs is rotated through 360 degrees. When the result shows a null, the two inputs are 180 degrees out-of-phase at the channel model. Applying the phase offset 180 degrees from the null will result in the inputs to the channel model being in-phase.

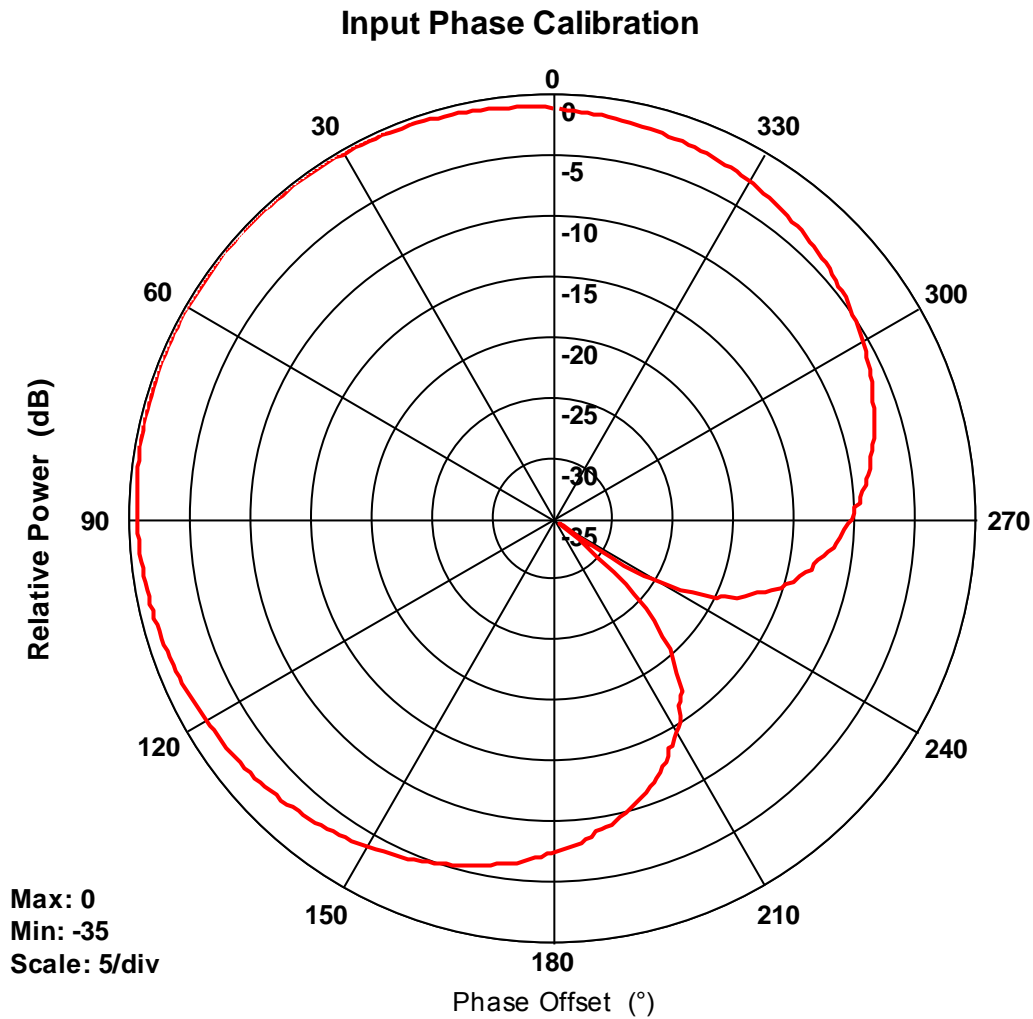

Figure 2.2.2.3-1 Sample Input Phase Calibration using a Spectrum Analyzer to Monitor the Output as a Phase Offset Is Applied to One Input of the Channel Emulator

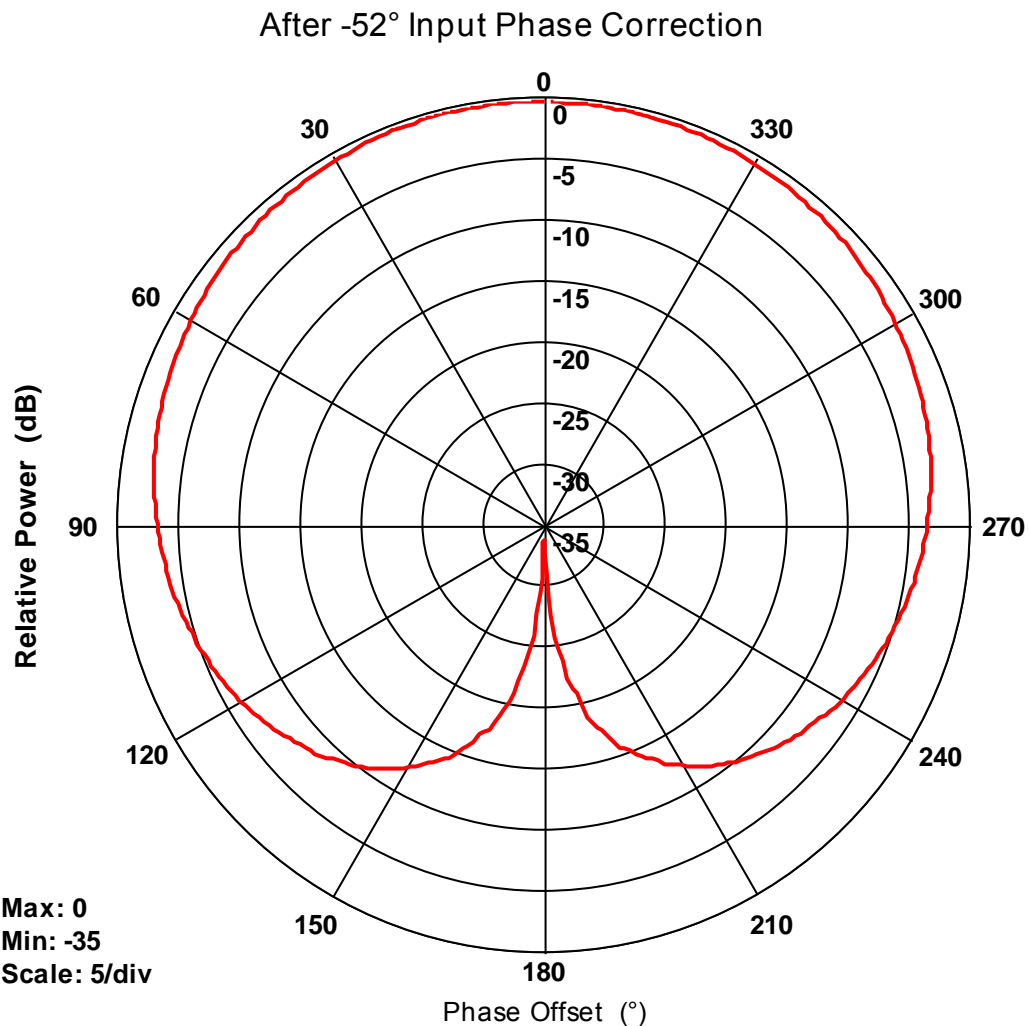

Figure 2.2.2.3-2 Result of Applying a Fixed -52° Offset Correction to the Channel Emulator Input Due to the Null Found at 232°

A more advanced approach suitable only for LTE requires demodulation of the LTE signal to detect the phases of the pilot channels and adjust the input phase reference appropriately. Test platform systems approved for CTIA testing must implement a variant of one of these approaches to provide quick input phase calibration and correction prior to the start of a device test.

2.3 DUT Positioning within the MPAC Test Volume

In order to minimize measurement uncertainty, it's important that CATLs ensure the DUT is oriented within the chamber's test zone in a standardized manner. Section 3.3 of *CTIA 01.71* [2] provides a preliminary set of normative DUT orientation conditions and the informative DUT orientation conditions are found in Section 3.5 of *CTIA 01.71* [2]. MIMO Average Radiated SIR Sensitivity (MARSS).

2.3.1 Introduction

This test is intended to determine the average MIMO receiver performance of an DUT for a given usage case and RF environmental condition. The test evaluates the DUT in a range of typical orientations for a given usage case and then determines a single figure of merit for that model and usage case combination. The MARSS orientation dependent performance should not be thought of as a radiation pattern, since at each orientation of the DUT, signals from multiple directions are received simultaneously

and combined by the antennas and radio receivers in whatever manner the DUT supports. There is no single direction around the DUT for which a given measurement defines the receiver performance in that direction. Instead, the MARSS orientation dependent information simply reflects the receiver performance for a given DUT orientation relative to the origin coordinates of the simulated RF environment in which it's being tested. The selection of orientations to be tested are intended to reflect a uniform distribution of the most common range of orientations such that no additional weighting is required to determine average performance.

2.3.2 eNodeB Emulator Configuration

The eNodeB emulator used to execute the Open-Loop Spatial Multiplexing (OL-SM) tests described in this document shall be configured according to [Table 2.3.2-1](#) (for FDD DUTs) or [Table 2.3.2-2](#) (for TDD DUTs) below.

Table 2.3.2-1 eNodeB Configuration Parameters for FDD Open-Loop Spatial Multiplexing (TM3, Rank 2) Tests Employing SIR Control

Parameter	Value
Downlink Bandwidth	10 MHz
Duplex Mode	FDD
Downlink Reference Channel	R.35 FDD as defined in 3GPP TS 36.521-1 Table A.3.3.2.1-1 [7]
Downlink Modulation	64QAM
Maximum Theoretical Throughput	35.424 Mbps
Minimum Number of Subframes per Stream	20000 (Note 1)
Downlink RS-EPRE	(Note 2)
Downlink TBS Index	
Subframe 0:	17
Subframes 1-4, 6-9:	18
Subframe 5:	Unused (0 RBs) (Note 3)
Downlink Transmission Mode	TM3
Number of MIMO eNodeB Transmit Antennas	2
Uplink TBS Index	6
Number of Uplink RBs	50
Uplink RB _{Start}	0
Transmit Power Control	(Note 4)
p-Max:	Max Power/All +1 dB

Parameter	Value
TX power control:	
Downlink Power Level Offsets	PSS = SSS = 0 dB PBCH = PCFICH = PHICH = PDCCH = -3 dB
PDSCH Power Offset Relative to RS-EPRE	$\rho_A = -3$ dB $\rho_B = -3$ dB
HARQ Transmissions	1 (No HARQ)
OCNG Pattern	None
AWGN Power Level	None
<p>Note 1: Throughput measurements performed at or adjacent to the target SIR sensitivity level shall be measured for the specified minimum number of subframes. Since the throughput and corresponding SIR sensitivity is a function of the variability caused by the fading of the channel model, a minimum test time is required to properly determine the fading throughput, and therefore statistical early exit techniques are not allowed when determining the final figure of merit. Labs are free to use any mechanism they wish to narrow the search to the approximate location of the SIR sensitivity point so long as the measurement(s) used to determine the SIR sensitivity target throughput meet or exceed the specified minimum number of subframes.</p> <p>Note 2: The RS-EPRE level generated in the test volume should be set near the maximum linear output level of the test system, while still providing enough headroom for linear amplification of both signal and interference for SIR testing. The signal must be far enough above the platform noise of the DUT to have a negligible impact on the resulting SINR but shall be no less than REFSENS as defined in Table 7.3.5-1 of 3GPP TS 36.521-1 [7] plus 40 dB. When determining the minimum RS-EPRE level generated in the test volume, the REFSENS value shall be converted to an equivalent RS-EPRE value based on the channel BW.</p> <p>Note 3: R.35 subframes 1-4 and 6-9 utilize DL TBS 18, while R.35 sub-frame 0 utilizes TBS 17. R.35 subframe 5 has zero resource blocks allocated. (See Table A.3.3.2.1-1 Fixed Reference Channel two antenna ports in 3GPP TS 36.521-1 [7] and 3GPP TS 36.213 [8] for additional information).</p> <p>Note 4: p-Max shall be set to a fixed value that is equivalent to 10 dB below the nominal maximum output power defined by the DUT power class (e.g. p-Max would be set to +13 dBm for a DUT with UE Power Class 3 as defined in clause 6.2.2.3 of 3GPP TS 36.521-1 [7]).</p>	

Table 2.3.2-2 eNodeB Configuration Parameters for TDD Open-Loop Spatial Multiplexing (TM3, Rank 2) Tests Employing SIR Control

Parameter	Value
Downlink Bandwidth	20 MHz
Duplex Mode	TDD
Downlink Reference Channel	3GPP TR 37.977 Table 7.1-3 [9]
Uplink/Downlink Frame Configuration	1
Special Subframe Configuration	7
Number of Downlink RBs	100
Downlink RBStart	0
Downlink Modulation	64QAM
Maximum Theoretical Throughput	29.512 Mbps
Minimum Number of Subframes per Stream	20000 (Note 1)
Downlink RS-EPRE	(Note 2)
Downlink TBS Index	16 , RMC Defined (Note 3)
Downlink Transmission Mode	TM3
Number of MIMO eNodeB Transmit Antennas	2
Rank Indicator	2 (forced)
Uplink Bandwidth	20 MHz
Uplink Modulation	QPSK
Uplink TBS Index	6
Number of Uplink RBs	100
Uplink RBStart	0
Transmit Power Control p-Max: TX power control:	(Note 4) Max Power/All +1 dB
Downlink Power Level Offsets	PSS = SSS = 0 dB PBCH = PCFICH = PHICH = PDCCH = -3 dB
PDSCH Power Offset Relative to RS-EPRE	$\rho_A = -3$ dB $\rho_B = -3$ dB

Parameter	Value
HARQ Transmissions	1 (No HARQ)
OCNG Pattern	None
AWGN Power Level	None

Note 1: Throughput measurements performed at or adjacent to the target SIR sensitivity level shall be measured for the specified minimum number of subframes. Since the throughput and corresponding SIR sensitivity is a function of the variability caused by the fading of the channel model, a minimum test time is required to properly determine the fading throughput, and therefore statistical early exit techniques are not allowed when determining the final figure of merit. Labs are free to use any mechanism they wish to narrow the search to the approximate location of the SIR sensitivity point so long as the measurement(s) used to determine the SIR sensitivity target throughput meet or exceed the specified minimum number of subframes.

Note 2: The RS-EPRE level generated in the test volume should be set near the maximum linear output level of the test system, while still providing enough headroom for linear amplification of both signal and interference for SIR testing. The signal must be far enough above the platform noise of the DUT to have a negligible impact on the resulting SINR but shall be no less than REFSSENS as defined in Table 7.3.5-1 of 3GPP TS 36.521-1 [7] plus 40 dB. When determining the minimum RS-EPRE level generated in the test volume, the REFSSENS value shall be converted to an equivalent RS-EPRE value based on the channel BW.

Note 3: This RMC is defined in 3GPP TR 37.977 Table 7.1-3 [9] Subframes 0, 1, 4, 6 and 9 utilize DL TBS 16, subframe 5 is unused for DL data transmission, and other subframes are for UL.

Note 4: p-Max shall be set to a fixed value that is equivalent to 10 dB below the nominal maximum output power defined by the DUT power class (e.g. p-Max would be set to +13 dBm for a DUT with UE Power Class 3 as defined in clause 6.2.2.3 of 3GPP TS 36.521-1 [7]).

2.3.3 Channel Model Definition

The SCME Urban Macro-cell (SCME UMA) channel model shall be used for the evaluation of MARSS performance. The cross-polarization power ratio in an SCME propagation channel is defined as:

$$XPR = XPR_V = XPR_H$$

where

$$XPR_V = \frac{S_{VV}}{S_{HV}} \text{ and } XPR_H = \frac{S_{HH}}{S_{VH}}$$

and

- S_{VV} is the coefficient for scattered/reflected power on V-polarization and incident power on V-polarization
- S_{VH} is the coefficient for scattered/reflected power on V-polarization and incident power on H-polarization
- S_{HV} is the coefficient for scattered/reflected power on H-polarization and incident power on V-polarization
- S_{HH} is the coefficient for scattered/reflected power on H-polarization and incident power on H-polarization

In [Table 2.3.3-1](#), the following SCME Urban Macro-cell is unchanged from the original SCME paper with added XPR values, direction of travel, and velocity.

Table 2.3.3-1 SCME Urban Macro-Cell Channel Model (UMa)

SCME Urban Macro-Cell								
Cluster #	Delay [ns]			Power [dB]			AoD [°]	AoA [°]
1	0	5	10	-3	-5.2	-7	82.0	65.7
2	360	365	370	-5.2	-7.4	-9.2	80.5	45.6
3	255	260	265	-4.7	-6.9	-8.7	79.6	143.2
4	1040	1045	1050	-8.2	-10.4	-12.2	98.6	32.5
5	2730	2735	2740	-12.1	-14.3	-16.1	102.1	-91.1
6	4600	4605	4610	-15.5	-17.7	-19.5	107.1	-19.2
Delay spread [ns]								839.5
Cluster AS AoD / AS AoA [°]								2/35
Cluster PAS shape								Laplacian
Total AS AoD / AS AoA [°]								7.9/62.4
Mobile speed [km/h] / Direction of travel [°]								30/120
XPR NOTE: V & H components based on assumed BS antennas								9 dB
Mid-paths Share Cluster parameter values for:								AoD, AoA, AS, XPR

2.3.4 Model Emulation of the Base Station Antenna Pattern

The emulated base station antennas shall be assumed to be dual polarized equal power elements with a fixed 0λ separation, 45 degrees slanted.

The slant 45-degree antenna is an “X” configuration and is modeled as an ideal dipole with isotropic gain and subject to a foreshortening of the slanted radiating element, which is observed to vary as a function of the path angle of departure. This foreshortening with AoD represents typical slanted dipole behavior and is a source of power variation in the channel model. The effective antenna pattern for this antenna is illustrated in [Figure 2.3.4-1](#).

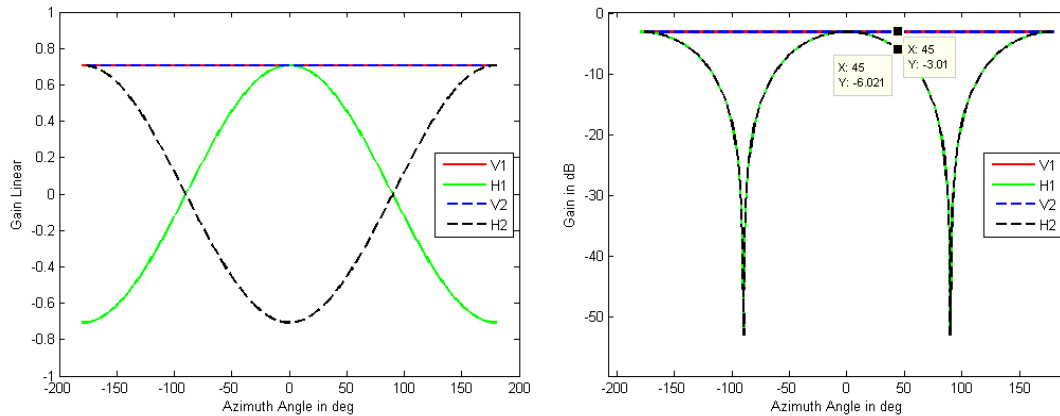

Figure 2.3.4-1 “X” Antenna Gain Assumption (a) Linear Gain (b) dB

2.3.5 Signal to Interference Ratio (SIR) Control for MARSS Measurement

2.3.5.1 SIR Control for the MPAC Test Environment

The MIMO OTA portion of this test plan utilizes a test equipment configuration based on control of the downlink signal to interference ratio (SIR) seen by the DUT. This test environment differs from that normally employed to assess receiver performance.

Receiver sensitivity is typically assessed in terms of the minimum downlink power which will provide a defined level of performance at the output of the receiver. For example, a test system used to measure reference sensitivity of an LTE DUT will establish the minimum downlink power required to obtain a specified data throughput. In this test configuration, the DUT’s low-signal performance is typically limited by its internal noise floor. While such a measurement is useful for the assessment of receiver sensitivity, it is not useful for MIMO performance assessment. Only in cases where a MIMO-capable DUT experiences no co-channel interference will its spatial-multiplexing performance be limited by its internal noise. Areas in which no co-channel interference exists are rare in actual networks.

In a typical network, co-channel interference (and therefore the SIR) will determine when spatial multiplexing can be supported. Therefore, it’s appropriate to assess the DUT’s spatial multiplexing performance in terms of the lowest SIR value at which a pre-defined data throughput can be obtained.

In the MIMO portion of this test plan, the MIMO-capable DUT will be exposed to a relatively high downlink signal power (PDSCH-EPRE) from the emulated serving cell while the level of an AWGN power source (which is used to emulate co-channel interference in an actual network) is varied. The AWGN noise power used to create the desired SIR within the test zone shall be represented by an unfaded, omnidirectional signal. Details of this AWGN injection approach are described in Section 2.3.5.2.

2.3.5.2 SIR Validation within the MPAC Test Zone

The interference level necessary to achieve a given SIR inside the test zone shall be generated as an independent process at each antenna probe with equal power, regardless of the signal power transmitted through that probe. The SIR is defined at resource element level as per 3GPP TS 36.521-1 clause 8.1.1 [7]. Figure 2.3.5.2-1 illustrates a typical configuration for measuring the power levels within the test volume. This may be used to determine the net power produced after balancing the output paths and in validating the SIR generated by the system.

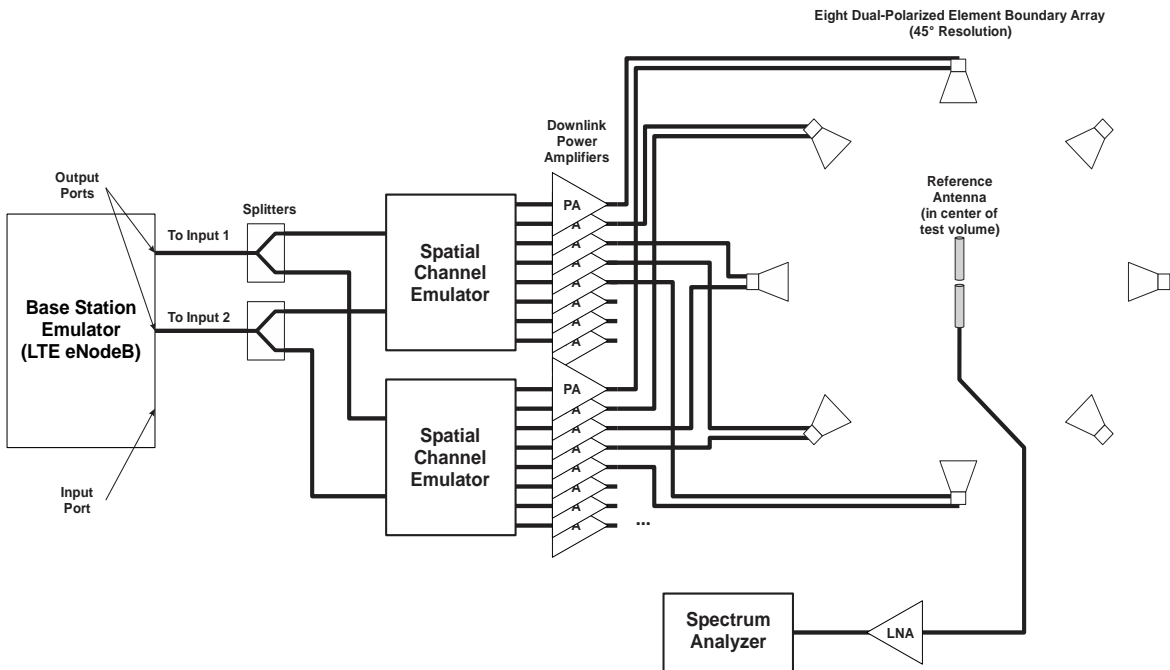

Figure 2.3.5.2-1 Typical Setup for Verifying SIR Level in the Anechoic Chamber Multi-Probe MIMO OTA Test System

The power and SIR validation shall be performed to ensure that all of the system corrections have been applied properly. Since the test essentially measures the residual error term in the system, and any measured error should be corrected for, the validation process may also be used as a final path loss correction. While the power validation process has a measurement uncertainty of its own, defined primarily by the reference antenna gain uncertainty, the cable loss correction uncertainty, and the receiver uncertainty, this may be smaller than the net uncertainty of the signal source components and path loss corrections applied. The results of the power and SIR validation may be used to correct for system-level offset(s) to further reduce measurement uncertainty if the validation uncertainty is less than the path loss measurement uncertainty. Note however that especially when determining the SIR, the interference level can easily be biased by the noise floor of the instrumentation. Care should be taken not to introduce invalid offsets due to noise in the validation test.

2.3.5.3 Downlink Power Measurement Considerations

The standard approach for measuring the average downlink power uses the integrated channel power method described in *CTIA 01.73* [4] with appropriate bandwidth filter corrections to determine the total power in the channel bandwidth for each measurement. It is critical that only the occupied channel bandwidth defined by 180 kHz times the downlink resource block allocation (e.g., 9 MHz for a 10 MHz channel) be measured during the validation process in order to measure the correct amount of AWGN interference and noise power corresponding to the occupied channel. This technique is generally possible using any modern spectrum analyzer even if the maximum resolution bandwidth of the analyzer is much narrower than the target data channel. Alternately, broadband time domain I/Q data may be used to determine the average downlink power provided the data can be Fourier transformed to the frequency domain and windowed to only record the total power within the occupied channel bandwidth. Ideally the same technique will be used to measure signal power, interference power, and noise power in order to minimize measurement uncertainty, so it is critical that only the desired occupied bandwidth be measured and that the power measurement can be performed in the absence of a modulated signal.

For FDD signals, the unused subframe 5 results in a measured average downlink power that is 9/10 of that of each occupied subframe. For the free running integrated channel power approach, this missing subframe is averaged randomly into the spectrum of the measured data and, assuming the signal is well

above the noise level of the spectrum analyzer, may be corrected by applying a 0.458 dB correction to the measured signal data. Using the broadband time domain data, it is possible to time gate out the missing subframe and simply use the average result from the remaining waveform.

For TDD signals, in addition to the unused subframe 5, there will be unused guard intervals and uplink data (see [Figure 2.3.5.3-1](#)) that are not part of the downlink power being validated. The uplink power in the signal prevents a simple numerical adjustment to the average of the entire signal. Instead, the unwanted signal must be gated out so that only the downlink signal is included in the average power. This requires synchronizing the analyzer with a frame trigger signal from the communication tester in order to be able isolate the desirable components from the undesired ones. For the integrated channel power approach, the synchronized frequency response trace ([Figure 2.3.5.3-2](#)) will contain the desired and undesired signals alternating as a function of frequency. There are a couple of alternatives to address this depending on the available test equipment and software. In all cases, the unwanted data shall be gated out of the measured data, taking care to discard points near the transition that may not reflect the actual downlink channel power. The gating may be done as a post-processing step, which will leave gaps in the frequency response trace. In order to fill in the gaps in the resulting frequency response curve, the signal power measurement shall be repeated as many times as necessary with appropriate trigger delays in order to measure the occupied subframes at the missing frequencies ([Figure 2.3.5.3-3](#)). Alternately, for spectrum analyzers equipped with an appropriate real-time gating feature, each trace may be measured as a single sweep where the analyzer pauses acquisition for the unused time slots. Since this mechanism is unlikely to allow more than one gate window, the period from just after the beginning of subframe 9 to the point just before the guard interval in subframe 1 shall be used (e.g. -0.9 ms to +1.6 ms from the start of frame trigger). Once a combined trace is generated by calculating the average downlink power measured at each frequency ([Figure 2.3.5.3-4](#)), or by using the onboard gated sweep function of the spectrum analyzer, the resulting signal trace is integrated to determine the total channel power. (Note these figures are for un-faded signals and represent very short sweep times for illustration purposes only.)

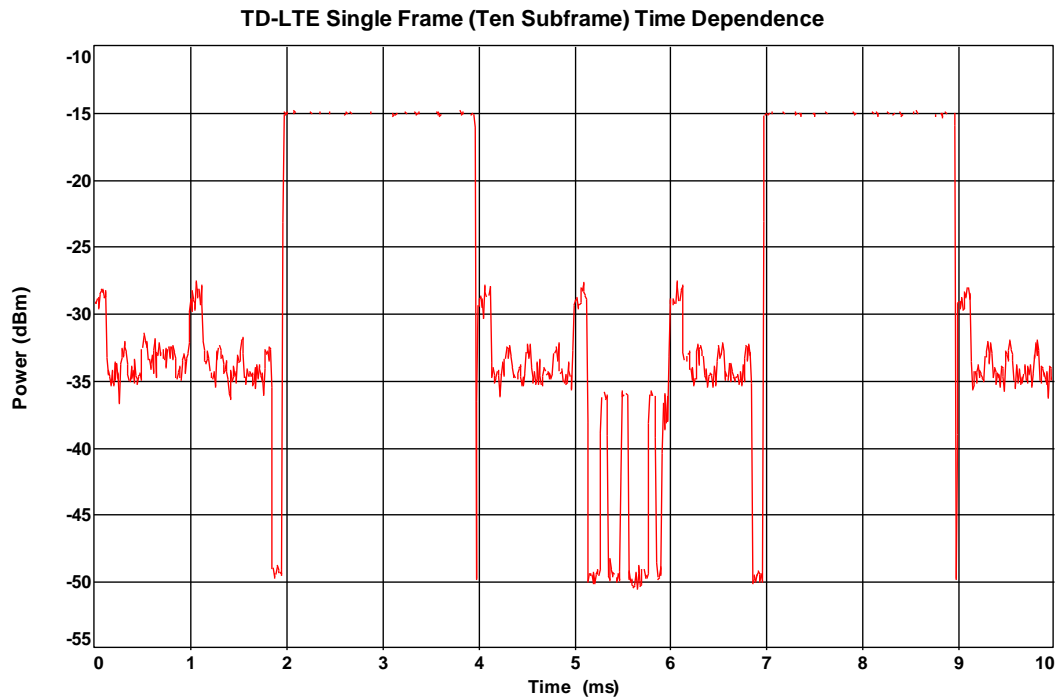

Figure 2.3.5.3-1 TD-LTE Frame Configuration Showing Special Subframes 1 and 6, Uplink in Subframes 2, 3, 7, & 8, and Unused Subframe 5

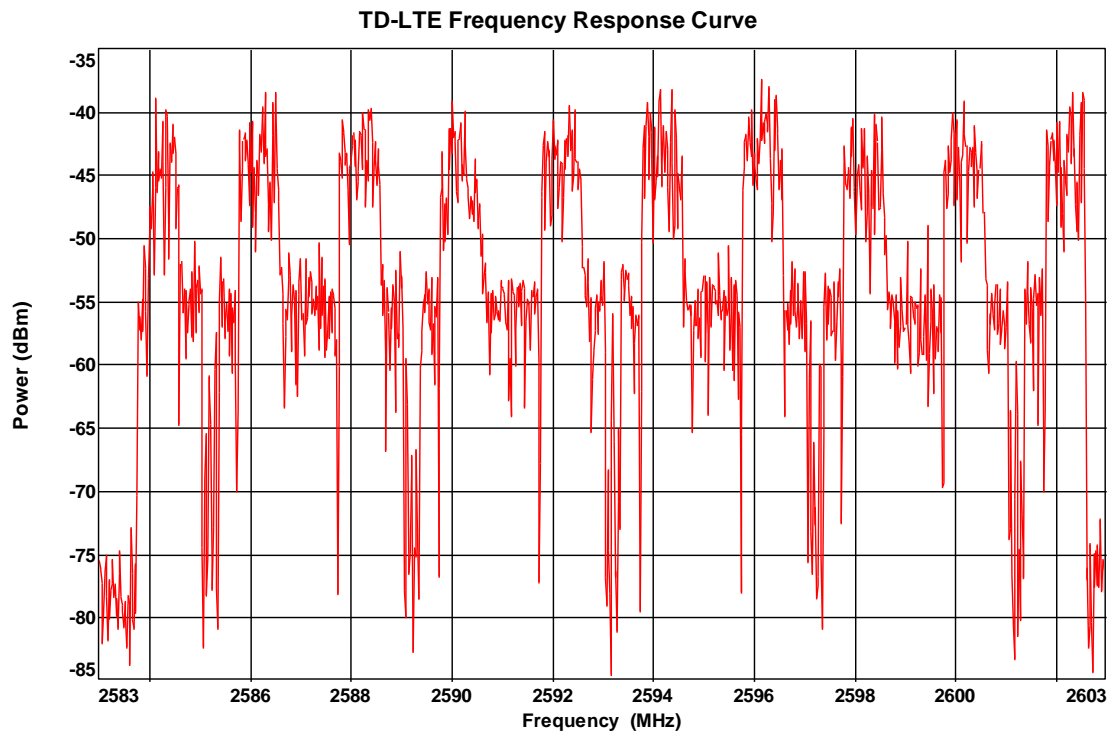

Figure 2.3.5.3-2 Swept Frequency Response of TD-LTE Signal Showing Frequency and Time Dependence

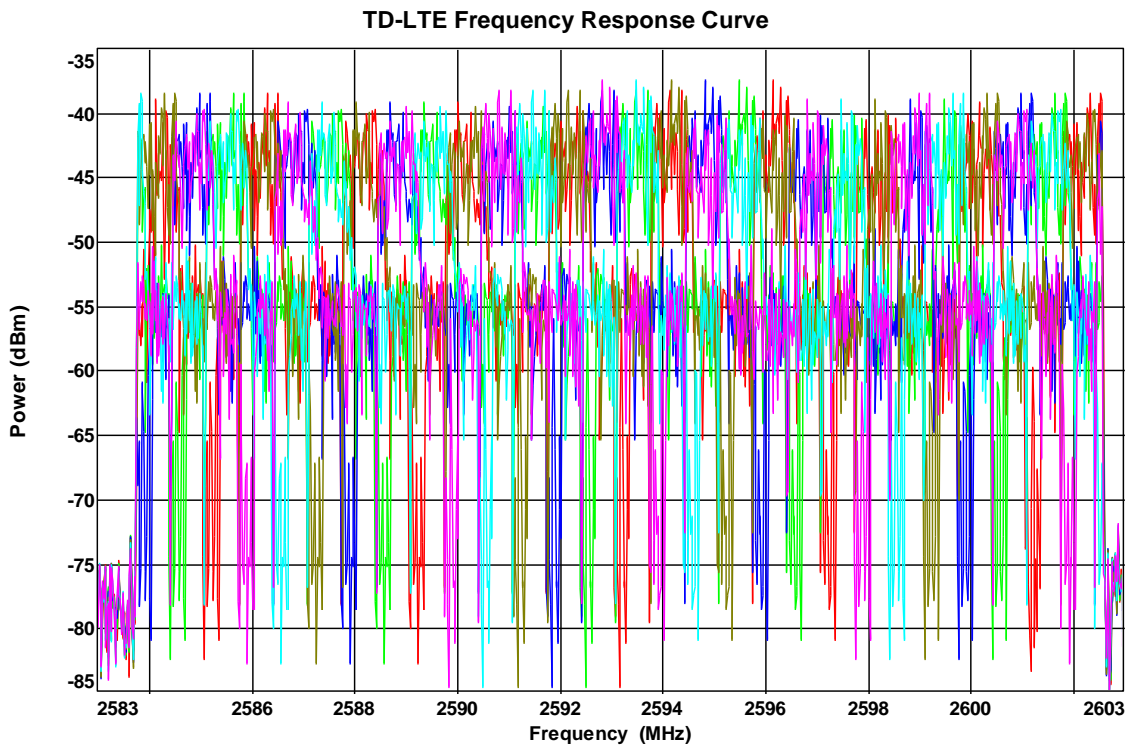

Figure 2.3.5.3-3 Swept Frequency Response of TD-LTE Signal With Multiple Trigger Offsets

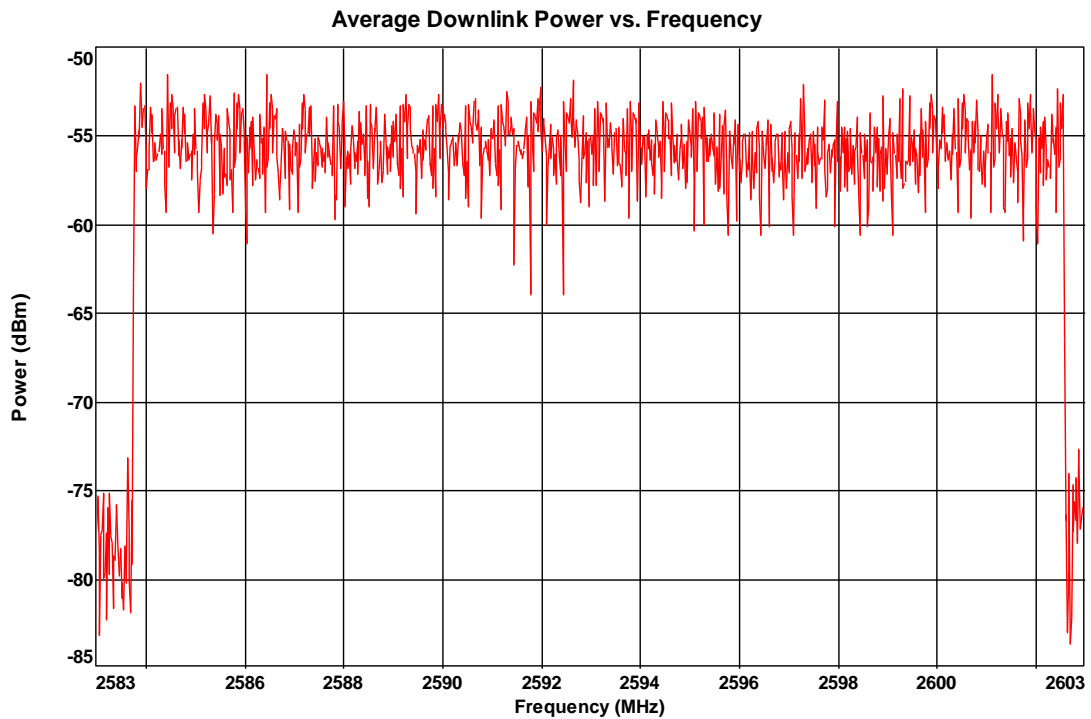

Figure 2.3.5.3-4 Average Of Remaining TDD Downlink Signal After Removal of Uplink and Unused Segments

Alternately, for TDD signals, the broadband time domain I/Q information may be time gated to eliminate the unwanted information and then the valid subframes and portions of the special subframes may be Fourier transformed to the frequency domain, windowed to the specified channel bandwidth, and integrated to determine the total channel power within the occupied time slots. Figure 2.3.5.3-5 illustrates the portions of the Fourier spectrogram to be integrated.

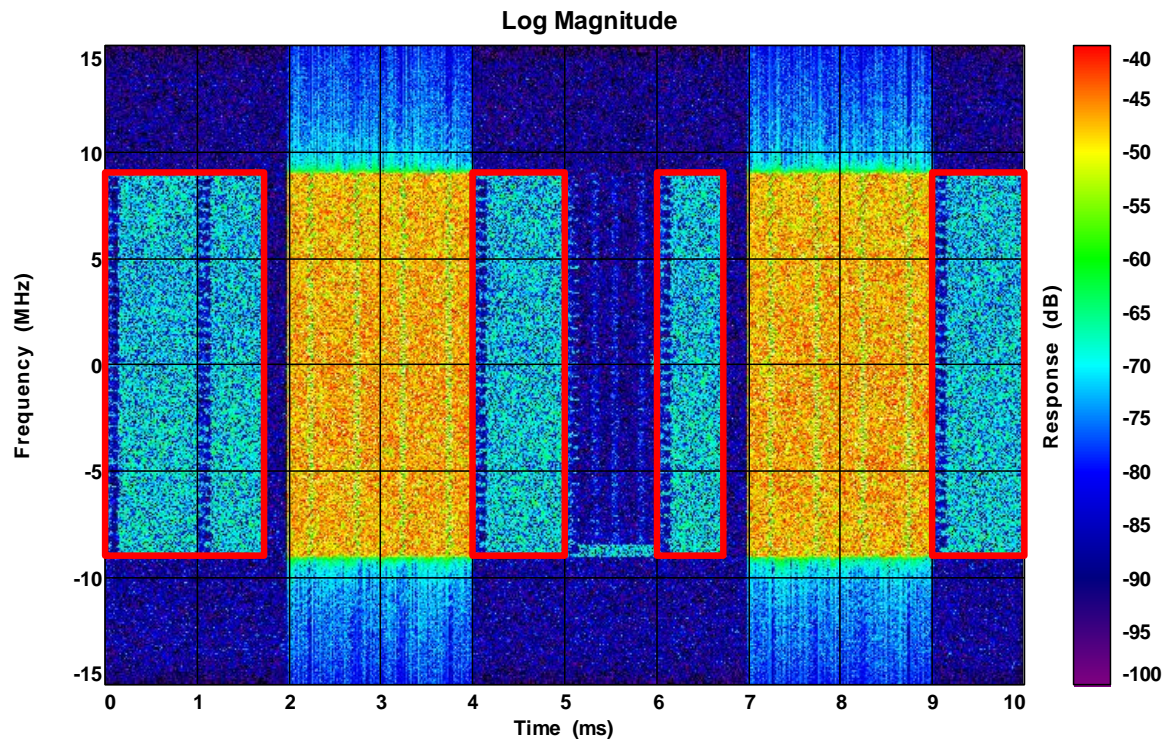

Figure 2.3.5.3-5 Fourier Spectrogram of TD-LTE Subframes Illustrating the Portion of the Downlink Signal to be Integrated Bordered in Red

1. Configure the spectrum analyzer with the settings given in table below. Use the integrated channel power method described in Section 3.5 of *CTIA 01.73* [4] with appropriate bandwidth filter corrections to determine the total power in the channel bandwidth for each measurement.
2. Load the target channel model into the channel emulator.
3. Configure the system gains for the LTE signal and injected interfering signal paths such that the signal is at the level to be used during DUT testing, and the interfering signal is set to achieve a target SIR of 0 dB.
4. Disable interfering signal injection (depending on the system configuration this may be configured within the channel emulator itself or in an external signal generator)
5. Connect a reference dipole to the spectrum analyzer via a cable and place the dipole vertically polarized in the center of the test volume. A low noise amplifier may be needed to properly measure the downlink and interference signals. Ensure that any amplifier is not overdriven.
6. With the channel emulator outputs disabled, measure the received power with the spectrum analyzer until the average power converges to within 0.1 dB to establish a noise floor of the instrumentation and record the value as P_{NRX} .

7. Enable the channel emulator outputs, start the emulation and measure the received signal power with the spectrum analyzer until the average power converges to within 0.1 dB and record the value as P_{VSRX} .
8. Compare the ratio of signal power to measurement noise ($P_{VSRX} - P_{NRX}$) to ensure that the downlink signal is at least 20 dB above the noise at the receiver.
9. Compensate for the loss of the cable and any amplifier between the reference antenna and the spectrum analyzer (α_{Cable}), the gain of the dipole reference antenna (G_{RA}) and the unoccupied bandwidth and time slots of the LTE signal (C_{LTE}) such that:

$$P_{VS} = P_{VSRX} - \alpha_{Cable} - G_{RA} - C_{LTE}$$

10. Without moving the antenna in the test volume, disable the LTE signal source and enable interference injection (depending on the system configuration this may be configured within the channel emulator itself or in an external signal generator).
11. Measure the received power with the spectrum analyzer until the average power converges to within 0.1 dB and record the value as P_{VIRX} .
12. Compare the ratio of interference power to measurement noise ($P_{VIRX} - P_{NRX}$) ensure that the signal is at least 20 dB above the noise at the receiver.
13. Compensate for the loss of the cable and any amplifier between the reference antenna and the spectrum analyzer (α_{Cable}) and the gain of the dipole reference antenna (G_{RA}) such that:

$$P_{VI} = P_{VIRX} - \alpha_{Cable} - G_{RA}$$

Repeat steps 2 to 13 using either a horizontally-polarized magnetic loop meeting the CTIA symmetry requirements and having a valid reference gain, or a horizontally polarized sleeve dipole instead of the vertically polarized reference dipole. For the loop, it is a good idea to perform a gain reference transfer between the loop and reference dipole to minimize error in the XPR validation. For the dipole, it is necessary to average multiple phi orientations of the dipole within the test volume and use the average of the theta gain pattern cut as the gain correction. This can be done by averaging across multiple steps, or slowly rotating the turntable continuously while the average power data is collected. A similar approach may also serve to address asymmetries in the loop pattern. Determine the resulting:

$$P_{HS} = P_{HSRX} - \alpha_{Cable} - G_{HRA} - C_{LTE}$$

and

$$P_{HI} = P_{HIRX} - \alpha_{Cable} - G_{HRA}$$

14. Calculate the total signal power received as

$$P_{Signal} = 10 \cdot \log_{10}(10^{P_{VS}/10} + 10^{P_{HS}/10}).$$

15. Calculate the total interfering signal power received as

$$P_{Interference} = 10 \cdot \log_{10}(10^{P_{VI}/10} + 10^{P_{HI}/10}).$$

16. Calculate the achieved signal to interference ratio as

$$SIR_{Achieved} = P_{Signal} - P_{Interference}$$

and validate that it matches the target SIR within the expected measurement uncertainty.

17. Calculate the achieved V/H ratio for the signal ($P_{VS} - P_{HS}$) and report the results.

18. Calculate the V/H ratio for the interference ($P_{VI} - P_{HI}$) and report the results.

Table 2.3.5.3-1 Spectrum Analyzer Settings for SIR Control Verification Using Integrated Channel Power

Parameter	Value
Center frequency	Channel frequency of band under test
Integrated Channel Span	FDD: 9 MHz (Note 1) TDD: 18 MHz
Resolution BW	30 kHz
Video BW	≥10 MHz (Maximum supported)
Number of Points	≥400
Detector	RMS
Number of traces averaged	≥100 or until result converges to better than 0.1 dB uncertainty
<p>Note 1: This value is based on a 10 MHz channel bandwidth. The integrated channel span shall be scaled as necessary if a bandwidth other than 10 MHz is employed.</p>	

2.4 MIMO OTA Test Methodology

2.4.1 Introduction

For each MIMO DUT, a set of measurement points shall be obtained which describe the DUT's MIMO receiver performance as a function of azimuthal positions within the simulated environment. For frequency operation <1GHz, the average signal to interference ratio (SIR) level that would result in 95%, 90% and 70% of the maximum throughput in each azimuthal position shall be determined. For frequency operation >1GHz, only the average SIR levels that result in 95% of the maximum throughput in each azimuthal position are required. Regardless of the method used to determine each throughput point, there shall be no more than 0.5 dB of separation between two complete throughput measurements. An average performance metric is then determined from the individual SIR levels determined at each orientation.

2.4.2 SIR-Controlled Test Procedure Using the MPAC

To perform an OL-SM SIR-controlled test using the MPAC, position the DUT within the test zone according to Section 2.3.1 with the azimuth positioner at zero degrees. Establish a connection to the DUT with the specified SCME UMa channel model and an SIR setting of 30 dB.

Note: In this test plan, SIR refers to the SIR illuminating the DUT in the test volume, as opposed to the SIR seen by the DUT's receiver.

Beginning with the initial orientation of the DUT at 0 degrees azimuth within the test volume, determine the SIR values associated with the 95%, 90%, and 70% outage levels based on the theoretical throughput rate using the specified minimum number of subframes and the maximum theoretical throughput called for in Table 2.3.2-1 (for FDD DUTs) or Table 2.3.2-2 (for TDD DUTs).

Note: Ensure that the transmitted power available from the DUT is sufficient to support error-free operation on the uplink. To ensure that any impact due to the DUT uplink power and/or the downlink omni-directional interferer is minimal, the percentage of DTX subframes over the measurement period shall be less than 0.25%.

When performing this measurement, the desired SIR result may be determined by interpolating to an SIR level between two throughput points measured within 0.5 dB of each other, or by reporting the last passing (higher) measured throughput point within 0.5 dB of the target. Algorithms that use fewer subframes and/or larger step sizes are acceptable provided the final reported data for each level is based on the result of two throughput measurements within 0.5 dB of each other and with the specified number of subframes. Due to the nature of the faded signal, early exit statistical measurement techniques are not allowed. Repeat the SIR sensitivity measurement described above every 30 degrees in azimuth, rotating the DUT clockwise, for a total of twelve positions. The SIR associated with each throughput outage point and azimuthal orientation shall be documented in Table RC.2-1 of *CTIA 01.03* [12].

If the DUT is unable to reach the throughput point(s) defined in Section 2.4.3 at an SIR of 30 dB, the lab shall document one of the following in Table RC.2-1 of *CTIA 01.03* [12] each azimuthal orientation where the DUT failed to meet the target throughput:

- a) An SIR value of 30 dB, or
- b) The linear average of the remaining SIR values where the DUT was able to reach the throughput point(s), plus 10 dB

The SIR substitution value employed for failing azimuthal orientations shall be the maximum SIR obtained from the two options above.

2.4.3 MARSS Figure of Merit

Let the MIMO average radiated SIR sensitivity (MARSS) be the figure of merit for the TM3 tests with SIR control. The sensitivity point is defined as the SIR value (in dB) required to reach the 70%, 90%, and 95% of the theoretical maximum throughput of the test case. Using these outage points for each throughput curve associated with each DUT rotation, let the SIR value (in dB) associated with each outage point at the m^{th} DUT rotation be the effective throughput SIR sensitivity ($P_{ETSS,70,m}$, $P_{ETSS,90,m}$, and $P_{ETSS,95,m}$). The MARSS is computed as a linear average from effective radiated sensitivity measurements across DUT rotations and is given by Equation 2.4.3-1 through Equation 2.4.3-3.

Equation 2.4.3-1

$$P_{MARSS,70} = 10 \log_{10} \left[\frac{1}{M} \sum_{m=1}^M 10^{\frac{P_{ETSS,70,m}}{10}} \right]$$

Equation 2.4.3-2

$$P_{MARSS,90} = 10 \log_{10} \left[\frac{1}{M} \sum_{m=1}^M 10^{\frac{P_{ETSS,90,m}}{10}} \right]$$

Equation 2.4.3-3

$$P_{MARSS,95} = 10 \log_{10} \left[\frac{1}{M} \sum_{m=1}^M 10^{\frac{P_{ETSS,95,m}}{10}} \right]$$

where M is the total number of DUT orientations.

Once SIR values associated with the 95%, 90% and 70% outage points have been obtained for all 12 azimuthal orientations of the DUT, enter the measured SIR values (to at least 0.5 dB resolution) in *CTIA 01.01* [1]. The DUT's pass/fail performance shall be assessed based on the following rules:

- a) The DUT must meet 70% throughput in all 12 azimuthal orientations. If the DUT fails to meet this criterion, the DUT shall fail the MIMO OTA test.
- b) The DUT must meet 90% throughput in at least 11 of the 12 azimuthal orientations. If the DUT fails to meet this criterion, the DUT shall fail the MIMO OTA test.
- c) The DUT must meet 95% throughput in at least 10 of the 12 azimuthal orientations. If the DUT fails to meet this criterion, the DUT shall fail the MIMO OTA test.

If all of the criteria above are met, the SIR values for the 70%, 90% and 95% outage levels shall be linearly averaged using [Equation 2.4.3-1](#), [Equation 2.4.3-2](#) and [Equation 2.4.3-3](#), respectively, after applying the substitution value (s), if applicable, for azimuthal orientations where the throughput outage point was not obtained.

Section 3 Common Uncertainty Contributions for MIMO Receiver Performance

3.1 Summary of Common Uncertainty Contributions for MIMO Receiver Performance

Table 3.1-1 lists common uncertainty contributions for the MIMO DUT receiver performance measurement defined in this test plan.

Table 3.1-1 Common Uncertainty Contributions for MIMO DUT Receiver Performance Measurement

No	Uncertainty Contribution	Reference	Comment
1.	Range Loss Measurement(s)	See Table 3.1-2	Net path loss measurement MU from signal reference to DUT.
2.	Mismatch: Communication Tester	See Section 2.1 of CTIA 01.70 [10]	Final system side mismatch between instrumentation and system.
3.	Signal Source Absolute Power Reference or Stability: Communication Tester	See Section 2.5 of CTIA 01.70 [10]	Depends on SIR Implementation
4.	Receiver Stability: Channel Emulator	See Section 2.4 of CTIA 01.70 [10]	
5.	Signal Source Linearity: Channel Emulator	See Section 2.5 of CTIA 01.70 [10]	Applies for variable power control.
6.	Signal Source Stability: Channel Emulator	See Section 2.5 of CTIA 01.70 [10]	Applies for variable interference control.
7.	Signal Source Absolute Power Reference or Linearity and Relative Error: AWGN Source	See Section 2.5 of CTIA 01.70 [10]	Contribution type depends on whether AWGN source is a separate generator or part of existing test equipment.
8.	Range Loss Measurement(s): AWGN Source	See Section 2.5 of CTIA 01.70 [10]	Applies to the associated portion of the path if a separate AWGN source with all or partially separate path to test volume is used.
9.	Mismatch: AWGN Generator(s)	See Section 2.1 of CTIA 01.70 [10]	Final system side mismatch between instrumentation and system. Applies if separate AWGN generator is used, requiring a separate calibration path.
10.	Measurement Antenna Cable Factor	See Section 2.2 of CTIA 01.70 [10]	
11.	Blocking Effect of the DUT on the Measurement Antenna (if too close)	See Section 2.9.3 of CTIA 01.70 [10]	
12.	Influence of the ambient temperature on the test equipment	See Section 2.12 of CTIA 01.70 [10]	
13.	Miscellaneous uncertainty	See Section 2.22 of CTIA 01.70 [10]	
14.	Minimum downlink/interference power step size uncertainty	See Section 2.20 of CTIA 01.70 [10]	
15.	Stability	See Section 2.7 of CTIA 01.70 [10]	

No	Uncertainty Contribution	Reference	Comment
16.	Linearity	See Section 2.7 of CTIA 01.70 [10]	
17.	Amplifier Noise	See Section 2.7 of CTIA 01.70 [10]	
18.	DUT Positioning Uncertainty Relative to Phantoms and Fixtures	See Section 2.13 of CTIA 01.70 [10]	
19.	Measurement Setup Repeatability	See Section 2.19 of CTIA 01.70 [10]	
20.	Effect of Ripple on DUT Measurements	See Section 2.10.2 of CTIA 01.70 [10]	
21.	Test System Frequency Flatness Uncertainty	See Section 2.28 of CTIA 01.70 [10]	

3.2 Summary of Common Uncertainty Terms for Path Loss Measurement

Table 3.1-2 lists the common uncertainty contributions for common path loss measurements used within this test plan. Depending on the range calibration approach used, the system may have one or more path loss measurement contributions to the measurement uncertainty.

Table 3.1-2 Common Uncertainty Contributions for MIMO Path Loss Measurement

No	Uncertainty Contribution	Reference	Comment
1	Mismatch: Loopback Cable	See Section 2.1 of CTIA 01.70 [10]	Mismatch contribution when obtaining reference level
2	Mismatch: Source Cable	See Section 2.1 of CTIA 01.70 [10]	Mismatch contribution at system input
3	Mismatch: Receive Cable	See Section 2.1 of CTIA 01.70 [10]	Mismatch contribution at system output
4	Signal Source Stability	See Section 2.5 of CTIA 01.70 [10]	
5	Receiving Device Linearity	See Section 2.4 of CTIA 01.70 [10]	
6	Reference Antenna: Gain/Efficiency of the calibrated reference antenna	See Section 2.8 of CTIA 01.70 [10]	For OTA range loss measurements only.
7	Reference Antenna: Range loss ripple contribution	See Section 2.10.3 of CTIA 01.70 [10]	For OTA range loss measurements only.
8	Reference Antenna: Offset of phase center of calibrated reference antenna from the axis(es) of rotation	See Section 2.9.2 of CTIA 01.70 [10]	For OTA range loss measurements only.

No	Uncertainty Contribution	Reference	Comment
9	Additional Insertion Loss(es) or Gains:	See Section 2.3 of CTIA 01.70 [10]	Any additional components (cables, switches, attenuators) not measured directly as part of the two-step path loss process will have their own path loss measurement uncertainty associated with the corrections applied.
10	Additional Mismatch Terms:	See Section 2.1 of CTIA 01.70 [10]	Any additional junction points (e.g. switches, cables, etc.) changed between calibration and device test steps will introduce additional mismatch uncertainty.

3.3 Combined and Expanded Uncertainties for Overall MIMO Receiver Performance

After calculation the combined standard uncertainties in [CTIA 01.70 \[10\]](#) they should be combined as follows to derive the overall combined standard uncertainty:

Equation 3.3-1

$$u_c = \sqrt{u_c^2 \text{ contribution from the EUT measurement} + u_c^2 \text{ contribution from the reference measurement}}$$

Next, the expanded uncertainty, U , is calculated as outlined in Section 2 of [CTIA 01.70 \[10\]](#). The resulting value for expanded uncertainty for MIMO receiver performance should be stated in the results sheet.

3.3.1 Compliance Criteria for the Overall MIMO Receiver Performance Uncertainty for MPAC

Table 3.3.1-1 Expanded Uncertainty Maximum Limit for MIMO Receiver Performance

Test Configuration	Expanded Uncertainty Max Limit (dB)
Free Space	2.75

Section 4 Validation and Verification of Test Environments and Test Conditions

This section describes the MIMO OTA validation measurements required to ensure that the test conditions are correctly implemented and hence capable of generating the propagation environment, as described by the model, within the designated test zone. Measurements are performed mainly with a vector network analyzer (VNA) and a spectrum analyzer. The system provider shall perform the validation tests at the frequency of the downlink for mid-range from 3GPP TS 36.508 [3] as required per band for the normative bands defined in Table 2.3.2-1 and Table 2.3.2-2

The specific settings of the VNA may be adjusted if other settings lead to better results.

4.1 Measurement Instrument Overview

4.1.1 Measurement Instruments and Setup

The measurement setup includes the following equipment:

Table 4.1.1-1 Required Measurement Equipment

Item	Quantity	Item
1	1	Channel Emulator
2	1	Signal Generator
3	1	Spectrum Analyzer
4	1	VNA
5	1	Magnetic Dipole
6	1	Sleeve Dipole
7	1	Signal Analyzer

4.1.2 Network Analyzer (VNA) Setup

Most of the measurements are performed with a VNA. An example set of equipment required for this setup is shown in Figure 4.1.2-1. The VNA transmits frequency sweep signals through the MIMO OTA test system and a test antenna, within the test area, receives the signal and the VNA analyzes the frequency response of the system. A number of traces (frequency responses) are measured and recorded by the VNA and analyzed by a post processing SW, e.g., Matlab. Special care has to be taken into account to keep the fading conditions unchanged, i.e., frozen, during the short period of time of a single trace measurement. The fading may proceed only in between traces. This setup can be used to measure PDP, spatial correlation, Doppler spectrum/temporal correlation and polarization of the SCME UMa channel model defined in Section 2.3.3.

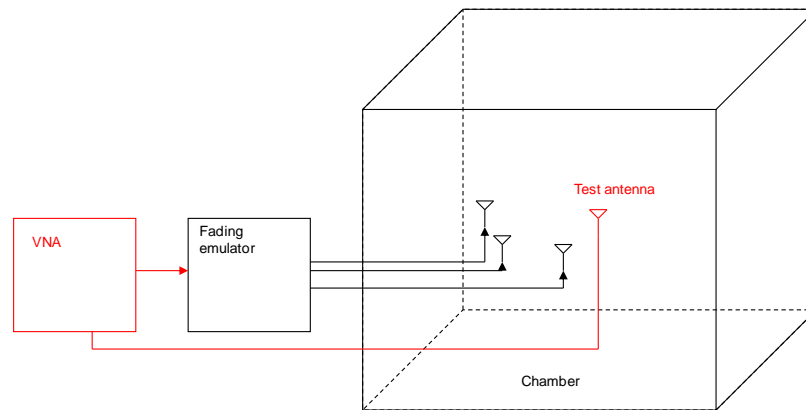

Figure 4.1.2-1 Setup for Anechoic Chamber VNA Measurements

4.1.3 Spectrum Analyzer (SA) Setup

The Doppler spectrum is measured with a spectrum analyzer as shown in [Figure 4.1.3-1](#). In this case a signal generator transmits a CW signal through the test system. The signal is received by a test antenna within the test area. Finally, the signal is analyzed by a spectrum analyzer and the measured spectrum is compared to the target spectrum. This setup can be used to measure Doppler spectrum of the SCME UMa channel model defined in [Section 2.3.3](#).

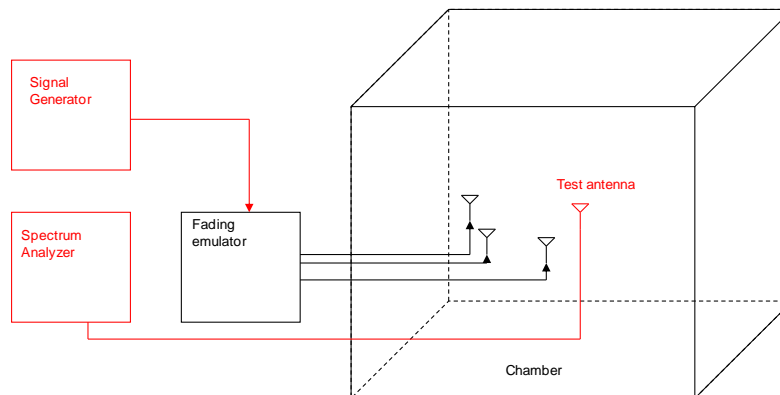

Figure 4.1.3-1 Setup for Spectrum Analyzer Measurements

4.1.4 Signal Analyzer (SAN) Setup

The spatial correlation is measured with a signal analyzer as shown in [Figure 4.1.4-1](#). In this case a signal generator transmits a CW signal through the OTA test system. The signal is received by a test antenna within the test area. Finally, the signal is collected by a signal analyzer and the measured signal is stored for postprocessing.

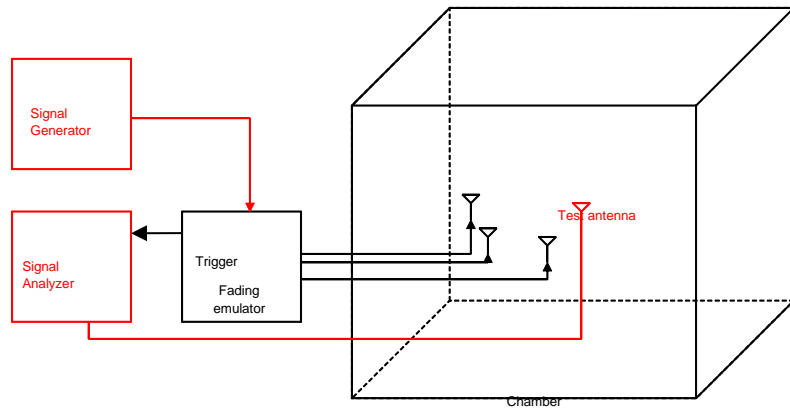

Figure 4.1.4-1 Setup for Signal Analyzer Measurements

4.2 Validation of the MPAC MIMO OTA Test Environment and Test Conditions

4.2.1 Validation of SIR-Controlled MPAC Test Environment

4.2.1.1 Validation of MPAC Power Delay Profile (PDP)

This measurement checks that the resulting power delay profile (PDP) is in-line with the PDP defined for the channel model.

Method of measurement: Step the emulation and store traces from the VNA, i.e. run the emulation to Channel Impulse Response (CIR) number 1, pause, measure the VNA trace, run the emulation to advance the time such that the distance between traces specified in Table 4.2.1.1-1 is met, pause, measure the VNA trace. Continue until 1000 VNA traces are measured.

Table 4.2.1.1-1 MPAC PDP VNA Settings

Item	Unit	Value
Center frequency	MHz	Downlink Center Frequency in 3GPP TS 36.508 [5] as required per band
Span	MHz	200
Number of traces		1000
Number of points		1101
Averaging		1

Table 4.2.1.1-2 MPAC PDP Channel Model Specification

Item	Unit	Value
Center frequency	MHz	Downlink Center Frequency in 3GPP TS 36.508 [5] as required per band
Distance between traces in channel model	wavelength (Note 1)	> 2

Item	Unit	Value
Channel model		As specified in Section 2.3.3
<p>Note 1: Time [s] = distance [λ] / MS speed [λ/s]</p> <p>MS speed [λ/s] = MS speed [λ/s] / Speed of light [m/s] * Center frequency [Hz]</p>		

4.2.1.2 Power Delay Profile Result Analysis

The measured VNA traces are recorded as linear relative voltage frequency responses $H(t, f)$, for each CIR time step τ (i.e. run the emulation to advance the time such that the distance between traces specified in Table 4.2.1.1-1 is met) The analysis is performed by taking the Fourier transform of each frequency response to generate impulse responses $h(t, \tau)$. The resulting impulse responses are averaged in power over the total number of CIR steps, T , as shown in Equation 4.2.1.2-1 below:

Equation 4.2.1.2-1

$$P(\tau) = \frac{1}{T} \sum_{t=1}^T |h(t, \tau)|^2$$

The resulting time domain data does not have enough resolution to resolve individual taps. In order to obtain an adequate representation of the relative power in each cluster, a running average is performed on each point of the resulting time domain power trace as shown in Equation 4.2.1.2-2. Note that for indices greater than the total number of points, N , the indexed power value wraps around to zero as indicated by the modulus operator, %,

Equation 4.2.1.2-2

$$PDP_i = \sum_{j=i}^{i+8} P_{j\%N}$$

Finally, the resulting PDP is shifted in delay, such that the first tap is on delay zero and normalized so that the peak value is one (zero dB). Finally, convert the PDP relative power trace to dB.

4.2.1.3 Measurement Antenna

The measurement antenna shall be a vertically-oriented sleeve dipole.

4.2.1.4 Pass/Fail Criteria

Table 4.2.1.4-1 indicates the expected target values for each cluster of the vertically polarized PDP after smoothing and normalization. The peak of each pulse for clusters 2-6 of the measured PDP shall meet these values to within ± 0.85 dB and ± 11 ns.

Table 4.2.1.4-1 SCME Urban Macro Target Values

Cluster #	Time (ns)	Relative Power (dB)
1	0	0
2	360	-2.2
3	255	-1.7
4	1040	-5.2
5	2730	-9.2
6	4600	-12.7

4.2.2 Validation of Doppler/Temporal Correlation for MPAC

This measurement checks the Doppler/temporal correlation.

4.2.2.1 MPAC Doppler/Temporal Correlation Method of Measurement

A signal generator is used to inject a CW signal as specified in Table 4.2.2.1-1 into one input of the channel emulator with the other input disabled. The channel emulator is configured as specified in Table 4.2.2.1-2 configured for free-run playback of the channel model. A vertically polarized sleeve dipole is used to probe the generated field structure in the center of the test volume and feed that signal to a spectrum analyzer. The Doppler power spectrum is measured by the spectrum analyzer using the settings provided in Table 4.2.2.1-3 and the result is recorded.

Table 4.2.2.1-1 MPAC Doppler/Temporal Correlation Signal Generator Settings

Item	Unit	Value
Center frequency	MHz	Downlink Center Frequency in 3GPP TS 36.508 [5] as required per band
Modulation		OFF

Table 4.2.2.1-2 MPAC Doppler/Temporal Correlation Spectrum Analyzer Settings

Item	Unit	Value
Center frequency	MHz	Downlink Center Frequency in 3GPP TS 36.508 [5] as required per band
Span	Hz	2000

Item	Unit	Value
RBW	Hz	1
VBW	Hz	1
Number of points		8001
Averaging		100

Table 4.2.2.1-3 Doppler Channel Model Specification

Item	Unit	Value
Center frequency	MHz	Downlink Center Frequency in 3GPP TS 36.508 [5] as required per band
Channel model		As specified in Section 2.3.3
Mobile speed	km/h	100 (Note 1)
Note 1: Or the maximum achievable value.		

The measurement result analysis is performed by taking the Fourier transformation of the Doppler power spectrum measured with the spectrum analyzer. The resulting temporal correlation function $R_t(\Delta t)$ is normalized such that $\max(\text{Re}(R_t(\Delta t))) = 1$ and the x -axis is scaled by the mobile speed divided by the wavelength at the center frequency in order to convert the axis from time to wavelengths. The results from the normalized peak of the curve to five wavelengths after that point are then recorded for comparison to the reference curves. The measured results shall fall within the upper and lower limits for the temporal correlation shown in Table 4.2.2.1-4 and plotted in Figure 4.2.2.1-1.

Table 4.2.2.1-4 MPAC Reference Temporal Correlation Limits for SCME Urban Macro

Separation Distance (Wavelengths)	Lower Correlation Limit	Upper Correlation Limit
0.00	0.980	1.000
0.05	0.940	1.000
0.10	0.880	0.980
0.15	0.790	0.920
0.20	0.690	0.830
0.25	0.580	0.730
0.30	0.470	0.630
0.35	0.385	0.545

Separation Distance (Wavelengths)	Lower Correlation Limit	Upper Correlation Limit
0.40	0.320	0.475
0.45	0.301	0.430
0.50	0.290	0.410
0.55	0.282	0.405
0.60	0.276	0.404
0.65	0.261	0.393
0.70	0.238	0.370
0.75	0.193	0.335
0.80	0.153	0.300
0.85	0.118	0.262
0.90	0.110	0.240
0.95	0.108	0.240
1.00	0.123	0.255
1.05	0.143	0.275
1.10	0.156	0.288
1.15	0.161	0.292
1.20	0.153	0.285
1.25	0.133	0.270
1.30	0.110	0.242
1.35	0.085	0.219
1.40	0.068	0.210
1.45	0.065	0.207
1.50	0.073	0.217
1.55	0.072	0.235
1.60	0.071	0.244
1.65	0.070	0.249
1.70	0.068	0.250

Separation Distance (Wavelengths)	Lower Correlation Limit	Upper Correlation Limit
1.75	0.067	0.243
4.50	0.000	0.170
5.00	0.000	0.156

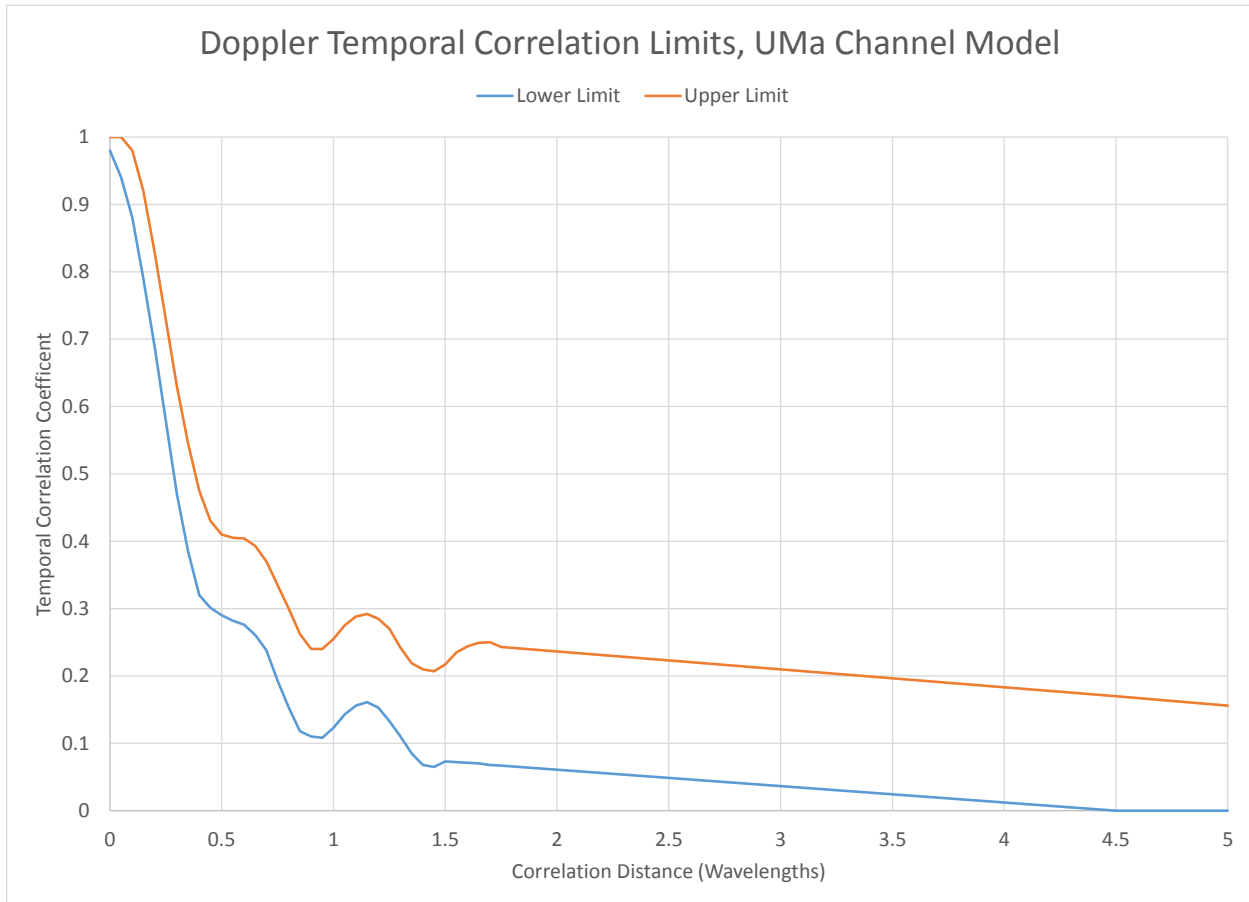

Figure 4.2.2.1-1 Reference Temporal Correlation Limits for SCME Urban Macro Plotted from Table A.2.2.1-4

4.2.2.2 MPAC Doppler/Temporal Correlation Measurement Antenna

The measurement antenna shall be a vertically-oriented sleeve dipole.

4.2.3 Validation of MPAC Spatial Correlation

This measurement checks whether the measured correlation curve follows the theoretical curve.

4.2.3.1 MPAC Spatial Correlation Method of Measurement

For each of the eleven specified positions and 1000 required CIR steps, step the emulation (i.e., run the emulation to advance the time such that the distance between traces specified in Table 4.2.3.1-1 met) and store traces from VNA. Continue until the center frequency response of 1000 CIRs in 11 positions (=1000*11 VNA traces) are measured. Assuming the channel emulation can be replayed exactly at each step, it's preferable to capture all CIR steps at each position prior to moving the antenna in order to minimize positioning uncertainty. In the event that the channel emulation cannot be replayed and stopped at exactly the same CIR step, each position may be measured at each CIR step while the emulation is paused, provided care is taken to reposition the antenna to within better than 0.005 wavelengths ($\pm 5\%$ positioning error) of the target position for each measurement. In either case, the paused channel emulator shall output the current state of the faded channel model continuously rather than reverting to an idle state.

Eleven test antenna positions shall be used to sample a segment of line of one wavelength in length with a sampling interval of 0.1 wavelengths. The antenna spacing shall be from -0.5 to +0.5 wavelengths from the center of the test volume, with a step size of 0.1 wavelength.

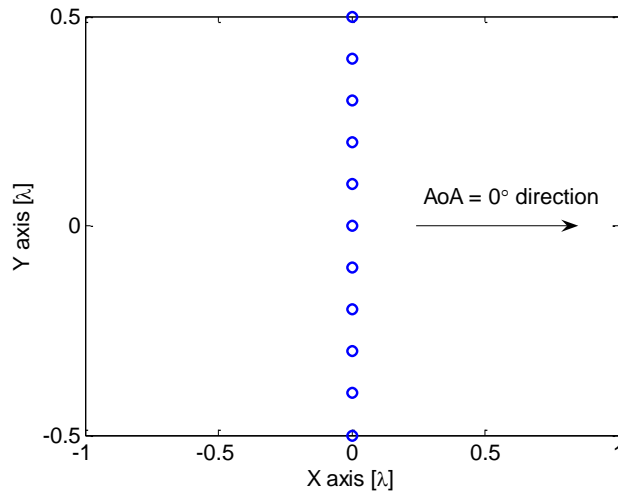

Figure 4.2.3.1-1 Test Antenna Positions

Table 4.2.3.1-1 MPAC Spatial Correlation VNA Settings

Item	Unit	Value
Center frequency	MHz	Downlink Center Frequency in 3GPP TS 36.508 [5] as required per band
Span	MHz	0 (Note 1)
Number of traces		1000
Number of points		1
Averaging		1
Note 1: An alternative approach using a non-zero span is acceptable as long as only the center point is used.		

Table 4.2.3.1-2 MPAC Spatial Correlation Channel Model Specification

Item	Unit	Value
Center frequency	MHz	Downlink Center Frequency in 3GPP TS 36.508 [5] as required per band
Distance between traces in channel model	Wavelength (Note 1)	> 2
Channel model		As specified in Section 2.3.3
Mobile speed	km/h	As needed to meet distance between traces requirement in Error! Reference source not found.
Note 1: Time [s] = distance [λ] / MS speed [λ/s] MS speed [λ/s] = MS speed [λ/s] / Speed of light [m/s] * Center frequency [Hz]		

4.2.3.2 Validation of MPAC Spatial Correlation Using Time Domain Techniques

Time domain techniques can also be used to validate spatial correlation. For this, the setup in [Figure 4.1.4-1](#) is used. The following three tables outline the settings for the channel emulator, signal generator, and signal analyzer respectively.

Table 4.2.3.2-1 MPAC Spatial Correlation Channel Model Specification

Item	Unit	Value
Center frequency	MHz	Downlink Center Frequency in 3GPP TS 36.508 [5] as required per band
Channel emulator mode	N/A	Free run
Channel model		As specified in Section 2.3.4
Mobile speed	km/h	30

Table 4.2.3.2-2 MPAC Spatial Correlation Signal Generator Settings

Item	Unit	Value
Center frequency	MHz	Downlink Center Frequency in 3GPP TS 36.508 [5] as required per band
Output Power	dBm	Function of the CE. Sufficiently above Noise Floor

Table 4.2.3.2-3 MPAC Spatial Correlation Signal Analyzer Settings

Item	Unit	Value
Center frequency	MHz	Downlink Center Frequency in 3GPP TS 36.508 [5] as required per band

Item	Unit	Value
Sampling	Hz	At least 15 times bigger than the max Doppler spread ($f_d = v/\lambda$)
Observation time	s	At least 16s. Channel Model length should be the same or greater than the observation time.

For each spatial point, the channel emulator should issue a trigger signal each time fading is started. For each point collect a time domain trace with the SAN, when done, stop fading. Data recording is synchronized with the channel emulator trigger.

4.2.3.3 MPAC Spatial Correlation Measurement Results Analysis

Calculate correlation of 1000 x 11 matrix $H(f)$ of frequency response samples. The procedure is to correlate the first column (the first dataset measured at half a wavelength from the center of chamber) with the 10 other columns as follows: (Matlab example)

```
for ind = 1:11;
    Corr (: , : , ind) = abs(corrcoef(H(: , 1),H(: , ind)));
end
Correlation = squeeze(Corr(1, 2, :));
```

The reference spatial correlation data for the channel model and BS antenna assumptions defined in Sections 2.3.3 and 2.3.4 as shown in Table 4.2.3.3-1 and plotted in Figure 4.2.3.3-1. The measured spatial correlation data shall fall within the upper and lower limits specified.

Table 4.2.3.3-1 MPAC Reference Spatial Correlation Function for SCME Urban Macro

Separation Distance (Wavelengths)	Ideal Free Space Correlation	Expected 8 Probe Correlation	Lower Limit	Upper Limit
0.0	1.000	1.000	0.990	1.000
0.1	0.952	0.951	0.925	0.975
0.2	0.828	0.826	0.770	0.870
0.3	0.683	0.680	0.615	0.735
0.4	0.583	0.580	0.530	0.640
0.5	0.543	0.541	0.493	0.595
0.6	0.517	0.518	0.465	0.575
0.7	0.467	0.480	0.410	0.540
0.8	0.401	0.448	0.350	0.510

Separation Distance (Wavelengths)	Ideal Free Space Correlation	Expected 8 Probe Correlation	Lower Limit	Upper Limit
0.9	0.355	0.466	0.300	0.530
1.0	0.342	0.528	0.290	0.600

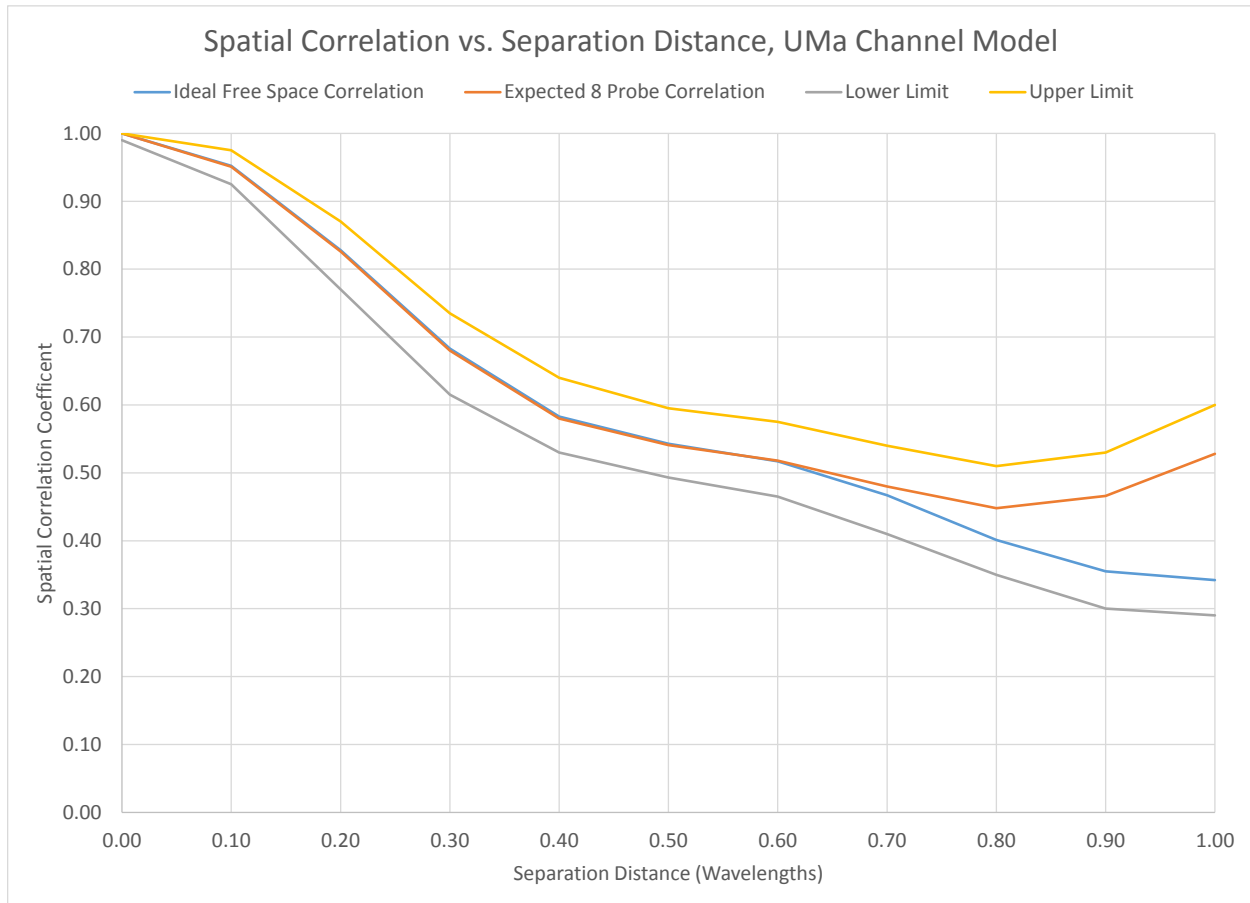

Figure 4.2.3.3-1 MPAC Reference Spatial Correlation Function for SCME Urban Macro plotted from Table A.2.3.1-3

4.2.3.4 MPAC Spatial Correlation Measurement Results Analysis using time domain technique

Calculate correlation of observation time x 11 matrix $h(t)$ of channel impulse responses. The procedure is to correlate first column (the trace measured at the one extreme of the slider) with the 10 other columns as follows (Matlab example)

```

for ind = 1:11;
    Corr (: , : , ind) = abs(corrcoef(H(: , 1),H(: , ind)));
end

Correlation = squeeze(Corr(1, 2, :));

```

The reference spatial correlation data for the channel model and BS antenna assumptions defined in Sections 2.3.3 and 2.3.4 as shown in Table 4.2.3.3-1 and plotted in Figure 4.2.3.3-1. The measured spatial correlation data shall fall within the upper and lower limits specified.

4.2.3.5 MPAC Spatial Correlation Measurement Antenna

The measurement antenna shall be a vertically oriented sleeve dipole.

4.2.4 Validation of Cross-Polarization for MPAC

This measurement checks how well the measured vertically or horizontally polarized power levels follow expected values.

4.2.4.1 MPAC Cross Polarization Method of Measurement

Step the emulation and store traces from the VNA.

Table 4.2.4.1-1 MPAC Cross-Polarization VNA Settings

Item	Unit	Value
Center frequency	MHz	Downlink Center Frequency in 3GPP TS 36.508 [5] as required per band
Span	MHz	10
Number of traces		1000
Number of points		201
Averaging		1

Table 4.2.4.1-2 MPAC Cross-Polarization Channel Model Specification

Item	Unit	Value
Center frequency	MHz	Downlink Center Frequency in 3GPP TS 36.508 [5] as required per band
Distance between traces in channel model	Wavelength (Note 1)	> 2
Channel model		As specified in Section 2.3.3
Mobile speed	km/h	30
<p>Note 1: Time [s] = distance [λ] / MS speed [λ/s] MS speed [λ/s] = MS speed [km/h] / Speed of light [m/s] * Center frequency [Hz]</p>		

4.2.4.2 MPAC Cross Polarization Measurement Procedure

1. Play or step through the channel model -> UMa X Corr

2. Measure the absolute power received at the center of the array, averaged over a statistically significant number of fades.
3. Use a vertically polarized sleeve dipole to measure the V component. Use a horizontally polarized (vertically oriented) magnetic loop dipole, or a horizontally polarized sleeve dipole to measure the H component. For the horizontally polarized sleeve dipole, it is necessary to average multiple phi orientations of the dipole within the test volume and use the average of the theta gain pattern cut as the gain correction. This can be done by averaging across multiple steps, or slowly rotating the turntable continuously while the average power data is collected.
4. Calculate the V/H ratio.
5. Compare it with the theoretical value of 8.13 dB for UMa.

4.2.4.3 Cross Polarization Expected Measurement Results

V/H ratio (composite, i.e., all 6 paths combined) of the 3GPP SCME UMa model is 8.13 dB. The BS antennas are isotropic dipoles with ± 45 degrees slant and subject to a foreshortening of the slanted radiating element. See channel model details and BS antenna assumptions specified in Sections [2.3.3](#) and [2.3.4](#), respectively. The measured validation result shall be within ± 0.9 dB of the theoretical target value.

4.2.5 Input Phase Calibration Validation (Normative)

In order to validate the phase calibration algorithms used during a typical test, the manual phase calibration procedure specified in Section [2.2.2.3](#) shall be performed to measure the result of a typical automated phase calibration. Care shall be taken to ensure that the communication tester is switched to an output mode suitable for such a test (i.e. turning off modulation or switching to a transmission matrix that generates the same signal on both output ports) without disabling the downlink signal and losing the phase reference between the two channels. The resulting null of the combined measurement shall be at $180^\circ \pm 5^\circ$.

Section 5 Test Zone Dimension Definitions

5.1 Test Zone Dimension Definitions for Normative Bands

The maximum antenna spacing in the DUT shall be defined as 1 wavelength at the center frequency of the middle channel of the downlink for the band under test (refer to [Table 5.1-1](#) and [Table 5.1-2](#)).

Table 5.1-1 Test Zone Dimension Definition for Normative FDD Bands of Operation

Operating Band	DL Channel Bandwidth (MHz)	DL Channel Number	DL Center Channel Frequency (MHz)	λ (m) at Center DL Channel	Test Volume Sphere Radius (m)
2 ¹	10	900	1960	0.153	0.076
4 ¹	10	2175	2132.5	0.141	0.070
5 ¹	10	2525	881.5	0.340	0.170
7	10	3100	2655	0.113	0.056
12 ¹	10	5095	737.5	0.406	0.203
13	10	5230	751	0.399	0.200
14	10	5330	763	0.393	0.196
17 ¹	10	5790	740	0.404	0.203
25 ¹	10	8365	1962.5	0.153	0.076
26 ¹	10	8865	876.5	0.342	0.171
30	10	9820	2355	0.127	0.064
66 ¹	10	66886	2155	0.139	0.070

Note 1: If the device supports both Band 2 and Band 25, then testing is only required in Band 25. If the device supports both Band 12 and Band 17, then testing is only required in Band 12. If the device supports both Band 4 and Band 66, then testing is only required in Band 66. If the device supports both Band 5 and Band 26, then testing is only required in Band 26.

Table 5.1-2 Test Zone Dimension Definition for Normative TDD Bands of Operation

Operating Band	DL Channel Bandwidth (MHz)	DL CHANNEL NUMBER	DL Center Channel Frequency (MHz)	λ (m) at Center DL Channel	Test Volume Sphere Radius (m)
41	20	40620	2593	0.116	0.058

5.2 Test Zone Dimension Definitions for Optional Bands

Certification bodies may utilize the test zone size dimensions described in [Table 5.2-1](#).

Table 5.2-1 Test Zone Dimension Definition for Optional FDD Bands of Operation

Operating Band	DL Channel Bandwidth (MHz)	DL Channel Number	DL Center Channel Frequency (MHz)	λ (m) at Center DL Channel	Test Volume Sphere Radius (m)
1	10	300	2140	0.140	0.070
3	10	1575	1842.5	0.163	0.081
6	10	2700	880	0.341	0.170
8	10	3625	942.5	0.318	0.159
9	10	3975	1862.4	0.161	0.080
10	10	4450	2140	0.140	0.070
11	10	4850	1485.9	0.202	0.101
18	10	5925	867.5	0.346	0.173
19	10	6075	882.5	0.340	0.170
20	10	6300	806	0.372	0.186
21	10	6525	1503.4	0.199	0.100
22	10	7000	3550	0.084	0.042
23	10	7600	2190	0.137	0.068
24	10	7870	1542	0.194	0.097
27	10	9125	860.5	0.348	0.174
28	10	9410	778	0.385	0.192
31	5	9895	465	0.645	0.322

Table 5.2-2 Test Zone Dimension Definition for Optional TDD Bands of Operation

Operating Band	DL Channel Bandwidth (MHz)	DL Channel Number	DL Center Channel Frequency (MHz)	λ (m) at Center DL Channel	Test Volume Sphere Radius (m)
34	15	36275	2017.5	0.149	0.074
35	20	36650	1880	0.159	0.080
36	20	37250	1960	0.153	0.076
37	20	37650	1920	0.156	0.078
38	20	38000	2595	0.116	0.058
39	20	38450	1900	0.158	0.079
40	20	39150	2350	0.128	0.064
42	20	42590	3500	0.086	0.043
43	20	44590	3700	0.081	0.041
44	20	46090	753	0.398	0.199

Section 6 Variable RMC MIMO Throughput Test (Informative)

6.1 Test Procedure

To perform an OL-SM SIR-controlled throughput test using a variable reference measurement channel in the MPAC, position the DUT within the test zone according to Section 2.3.1 with the azimuth positioner at zero degrees. Establish a connection to the DUT with the specified SCME Uma channel model and an SIR setting of 25 dB. Configure the DUT to report CSI information using the CSI reporting settings in Table A.3.3.3.3-1 of *3GPP TR 37.901* [11]. Configure the network emulator to use TM3 but allow MCS and rank to change based on UE CQI/RI feedback using the guidelines in Appendix B.2.2 of *3GPP TR 37.901* [11] (e.g. CQI to MCS mapping, RI mapping per Appendix B.2.2.7, etc.). The network emulator shall adjust the MCS index per Table B.2.2.1-8 of *3GPP TR 37.901* [11] for a 10 MHz FDD channel and per Table B.2.2.1-12 of *3GPP TR 37.901* [11] for a 20 MHz TDD channel.

Note: In this test plan, SIR refers to the SIR illuminating the DUT in the test volume, as opposed to the SIR seen by the DUT's receiver.)

Beginning with the initial orientation of the DUT at 0 degrees azimuth and 25 dB SIR, measure the throughput over 60,000 subframes using the specified SCME Uma channel model and the settings in Tables A.3.1-2 or A.3.1-3, as applicable, and Table A.3.3.3.3-1 (excluding the \hat{E}_s and N_{oc} settings).

While the throughput test is in progress, the network emulator shall adjust the MCS and number of code words based on the CSI reports from the DUT (following Appendix B.2.2 of *3GPP TR 37.901* [11]). Repeat the throughput measurement at SIR values of 15 dB and 5 dB. Repeat the throughput measurements described above every 30 degrees in azimuth, rotating the DUT clockwise, for a total of twelve positions. The throughput at each SIR level and azimuthal orientation shall be recorded and documented per *CTIA 01.03* [12]. In addition, the MCS index (histogram, minimum, median, and maximum) and the percentage of subframes transmitted with one or two code words for all subframes containing PDSCH data shall be recorded and documented per *CTIA 01.03* [12].

The RS-EPRE level generated in the test volume should be set near the maximum linear output level of the test system, while still providing enough headroom for linear amplification of both signal and interference for SIR testing. The signal must be far enough above the platform noise of the DUT to have a negligible impact on the resulting SINR but shall be no less than REFSSENS as defined in Table 7.3.5-1 of *3GPP TS 36.521-1* [7] plus 40 dB. When determining the minimum RS-EPRE level generated in the test volume, the REFSSENS value shall be converted to an equivalent RS-EPRE value based on the channel BW.

Ensure that the transmitted power available from the DUT is sufficient to support error-free operation on the uplink. p-Max shall be set to a fixed value that is equivalent to 10 dB below the nominal maximum output power defined by the DUT power class (e.g. p-Max would be set to +13 dBm for a DUT with UE Power Class 3 as defined in clause 6.2.2.3 of *3GPP TS 36.521-1* [7]).

Note: Ensure that the test system allows sufficient settling time for DUT when changing SIR level and/or azimuth position.

Repeat the throughput measurements above for all mechanical use cases.

Appendix A Revision History

Date	Version	Description
February 2022	4.0.0	Initial release. The following changes were made compared to Version 1.2.2 of Test Plan for 2x2 Downlink MIMO and Transmit Diversity Over-the-Air Performance Section 2: <ul style="list-style-type: none"> • Reduction of FoMs from three thresholds (95%, 90%, and 70%) to one threshold (95%) for > 1GHz bands • Clarification of the test requirements for 4Rx devices Section 4: Introduction of time domain techniques for spatial correlation validation
December 2022	5.0.0	No changes in this release.
March 2023	6.0.0	No changes in this release.