



# Test Plan for Wireless Device Over-the-Air Performance

---

## CTIA 01.52 Wireless Technology, Non-3GPP Radio Access Technologies

Version 6.0.0

March 2023

**© 2001 - 2023 CTIA Certification. All Rights Reserved.**

Any reproduction, modification, alteration, creation of a derivative work, or transmission of all or any part of this publication ("Test Plan"), in any form, by any means, whether electronic or mechanical, including photocopying, recording, or via any information storage and retrieval system, without the prior written permission of CTIA Certification, is unauthorized and strictly prohibited by federal copyright law. This Test Plan is solely for use within the CTIA Certification Program. Any other use of this Test Plan is strictly prohibited unless authorized by CTIA Certification or its assigns in writing.

## Use Instructions

All testing shall be performed in a CTIA Certification Authorized Test Lab and shall be initiated through one of the following methods:

1. By submitting a PTCRB or IoT Network Certified device certification request at <https://certify.ptcrb.com/>
2. By submitting an OTA Test Plan use request at <https://certify.ctiacertification.org/>

CTIA Certification LLC  
1400 16th Street, NW  
Suite 600  
Washington, DC 20036

1.202.785.0081

[programs@ctiacertification.org](mailto:programs@ctiacertification.org)

[ctiacertification.org/test-plans/](https://ctiacertification.org/test-plans/)

# Table of Contents

Section 1	Introduction .....	5
1.1	Purpose .....	5
1.2	Scope.....	5
1.3	Referenced Documents .....	5
Section 2	Bluetooth® Basic Rate (Informative) .....	6
2.1	Bluetooth Basic Rate TRP Test Procedure .....	6
2.2	OTA Reporting for Bluetooth Basic Rate TRP .....	8
2.3	Bluetooth Basic Rate TIS Test Procedure.....	8
2.4	OTA Reporting for Bluetooth Basic Rate TIS .....	10
Section 3	ZigBee (Informative) .....	11
3.1	ZigBee TRP Test Procedure .....	11
3.2	ZigBee TIS Test Procedure .....	13
3.3	ZigBee Reporting the Results.....	15
3.4	ZigBee Command Module and Test Case Flow.....	17
Section 4	Bluetooth Low Energy (LE) (Informative) .....	27
4.1	Bluetooth LE TRP Test Procedure .....	27
4.1.1	OTA Reporting for Bluetooth LE TRP.....	28
4.2	Bluetooth LE TIS Test Procedure.....	29
4.2.1	Test Procedure for Fast PER .....	30
4.2.2	Test Procedure for BLE sensitivity per Bluetooth SIG.....	30
4.2.3	OTA Reporting for Bluetooth LE TIS .....	31
Appendix A	Revision History .....	32

## List of Figures

Figure 3.1-1 TRP Block Diagram Set Up for Zigbee.....	13
Figure 3.2-1 TIS Block Diagram Set Up for Zigbee .....	15
Figure 3.4-1 Zigbee Total Radiated Power Test Case Command Flow .....	25
Figure 3.4-2 Zigbee Total Isotropic Sensitivity Test Case Command Flow .....	26

## List of Tables

Table 2.1-1 Bluetooth Basic Rate Communication Settings for TRP.....	6
Table 2.1-2 RF TX Measurement Equipment Settings for Bluetooth Basic Rate .....	7
Table 2.1-3 Bluetooth Basic Rate Test Channels for TRP Using “Loop Back” or “Tx Mode” .....	7
Table 2.2-1 Bluetooth Basic Rate TRP Test Results .....	8
Table 2.3-1 Bluetooth Basic Rate Communication Settings for TIS .....	8
Table 2.3-2 RF RX Sensitivity Measurement for Bluetooth Basic Rate.....	9
Table 2.3-3 Bluetooth Basic Rate Test Channels for TIS Using “Loop Back” .....	9
Table 3.1-1 Spectrum Analyzer Settings for Zigbee .....	12
Table 3.1-2 Zigbee Channel Settings .....	12
Table 3.2-1 Zigbee Parameter Settings for RSS Method .....	14
Table 3.3-1 Zigbee Total Radiated Power .....	16
Table 3.3-2 Zigbee Total Isotropic Sensitivity .....	16
Table 4.1-1 RF Instrument Measurement Settings.....	27
Table 4.1-2 Modes for Bluetooth LE Transmitter Test.....	28
Table 4.1-3 Bluetooth LE Test Channels .....	28
Table 4.1.1-1 Bluetooth LE TRP Test Results .....	29
Table 4.2-1 Modes for Bluetooth LE Receiver Test.....	30
Table 4.2.3-1 Bluetooth LE TIS Test Results.....	31

## Section 1 Introduction

### 1.1 Purpose

The purpose of this document is to define the test parameters used with all wireless non-3GPP radio access technologies that may be used with one or more OTA test methodologies.

### 1.2 Scope

This document cites references to standards describing the non-3GPP radio access technologies and defines the specific test parameters used to enable standardized OTA testing.

### 1.3 Referenced Documents

The following documents are referenced in this document:

[1] CTIA 01.71, <i>Positioning Guidelines</i>
[2] <i>Bluetooth® Test Specification</i> , RF PHY, RF-PHY.TS-4.2.1, July 14, 2015
[3] CTIA 01.72, <i>Near-Field Phantoms</i>
[4] CTIA 01.20, <i>Test Methodology, SISO, Anechoic Chamber.</i>
[5] CTIA 01.01, <i>Test Scope, Requirements, and Applicability</i>
[6] <i>Bluetooth Specification, Bluetooth Core Specification</i> , v5.2, December 31, 2019

## Section 2 Bluetooth® Basic Rate (Informative)

**Note:** The use of "shall" or "must" in the test procedures listed herein is only used to indicate that the test purpose, procedure, and/or result may not be as expected if the specified "shall" or "must" item is not used or followed. As this Section is informative in nature, the use of "shall" or "must" in the test procedures is not meant to imply a specific requirement. Their use is meant to indicate instances where the test objectives of the recommended test procedures may not be achieved if these recommendations are not followed.

### 2.1 Bluetooth Basic Rate TRP Test Procedure

This procedure is intended for Bluetooth Basic Rate DUTs.

The DUT shall be configured as specified in *CTIA 01.71 [1]*. The power radiated by the DUT shall be measured using a calibrated and accurate RF measuring instrument capable of measuring peak and average power across bursts. Communication settings shall be the same as the *Bluetooth Test Specification [2]*, RF PHY, Section 4.5.1, test case RF/TRM/CA/BV-01-C, with the following settings, exceptions summarized in [Table 2.1-1](#).

Table 2.1-1 Bluetooth Basic Rate Communication Settings for TRP

Test Mode	Loop Back/TX Mode
TX Power	UE transmits at max power
Hopping	Off
Packet Type	DH-1
Payload Length	27 bytes
Payload Type	PRBS 9

The settings for the RF TX measurement equipment shall be equivalent to the settings in [Table 2.1-2](#).

Table 2.1-2 RF TX Measurement Equipment Settings for Bluetooth Basic Rate

Span	Zero Span
Resolution Bandwidth	3 MHz
Video Bandwidth	3 MHz
Detector	Peak
Sweep Time	1 ms
Trigger	external (from signaling unit)
Reported Power	average power over at least 20% to 80% of the duration of the burst
Number of samples to average	10

The conducted power of the DUT shall also be measured at the antenna connector, if available, on all applicable frequencies. It is preferable that the DUT be the same as utilized for the TRP measurements. However, if the DUT does not readily support an antenna port for conducted measurements, a separate modified DUT may be provided for all conducted measurements. If no connector is available, the conducted power measurement is not required. Ideally, the power measurement will be performed with the same instrumentation in an equivalent configuration in order to minimize the measurement uncertainty involved. A different power measurement device may be used as long as any differences in absolute measurement accuracy are accounted for, either in corrections to the recorded power or increased reported measurement uncertainty for the conducted measurement. Refer to *CTIA 01.71 [1]* for more information on conducted power measurements and cabling setups.

Tests shall be performed with these settings:

- Communication settings equivalent to those shown in [Table 2.1-1](#)
- RF TX measurement equipment settings equivalent to those shown in [Table 2.1-2](#)
- The low, middle and high channels as defined in [Table 2.1-3](#)

Table 2.1-3 Bluetooth Basic Rate Test Channels for TRP Using “Loop Back” or “Tx Mode”

Loop Back		Low	Mid	High
TX (DUT)	Frequency (MHz)	2402	2441	2480
	Channel	0	39	78
RX (DUT)	Frequency (MHz)	2480	2402	2402
	Channel	78	0	0

Head and hand phantom, hand phantom only, wrist-worn and/or free-space testing shall be conducted based on device type, as specified in *CTIA 01.01* [5]. Refer to *CTIA 01.71* [1] for head/hand positioning requirements and wrist-worn positioning requirements.

## 2.2 OTA Reporting for Bluetooth Basic Rate TRP

Results shall be reported as specified below using the figures of merit given in *CTIA 01.01* [5].

Table 2.2-1 contains the OTA test results for Bluetooth Basic Rate. Reports shall include results for free-space, head/hand and wrist-worn configurations (if applicable) across all channels measured with the DUT antenna extended and retracted (if applicable).

Table 2.2-1 Bluetooth Basic Rate TRP Test Results

TRP								
Channel	Frequency (MHz)	FS	HL	HR	BHHL	BHR	WL	WR
0	2402							
39	2441							
78	2480							

## 2.3 Bluetooth Basic Rate TIS Test Procedure

Bluetooth Basic Rate Receiver Sensitivity measurements shall be performed using a communication tester to determine the DUT's receiver sensitivity by reporting the minimum forward-link power resulting in 0.1% Bit Error Rate (BER) with intentionally degraded "Dirty Packets". Refer to *CTIA 01.72* [3] for set-up illustrations. Communication settings shall be the same as the *Bluetooth Test Specification* [2], RF PHY Section 4.6.1, test case RF/RCV/CA/BV-01-C, with the following settings/exceptions summarized in Table 2.3-1.

Table 2.3-1 Bluetooth Basic Rate Communication Settings for TIS

Test Mode	Loop Back
TX Power	UE transmits at max power
Hopping	Off
Packet Type	DH-1
Payload Length	27 bytes
Payload Type	PRBS 9
Dirty TX	On

The settings for the RF RX sensitivity measurement are defined in Table 2.3-2.



Table 2.3-2 RF RX Sensitivity Measurement for Bluetooth Basic Rate

Error Rate Measurement	BER
BER Threshold	0.10%
Number of Packets	500

Table 2.3-3 lists the channel configurations to be used for TIS testing.

Table 2.3-3 Bluetooth Basic Rate Test Channels for TIS Using “Loop Back”

Loop Back		Low	Mid	High
RX (DUT)	Frequency (MHz)	2402	2441	2480
	Channel	0	39	78
TX (DUT)	Frequency (MHz)	2480	2402	2402
	Channel	78	0	0

The conducted sensitivity of the DUT shall also be measured at the antenna connector, if available, at all applicable frequencies. It is preferable that the DUT be the same as utilized for the TIS measurements. However, if the DUT does not readily support an antenna port for conducted measurements, a separate modified DUT may be provided for all conducted measurements. If no connector is available, the conducted sensitivity measurement is not required. Ideally, the sensitivity measurement will be performed with the same instrumentation in an equivalent configuration in order to minimize the measurement uncertainty involved. A different sensitivity measurement device may be used as long as any differences in absolute measurement accuracy are accounted for, either in corrections to the recorded sensitivity level or increased reported measurement uncertainty for the conducted measurement. Refer to [CTIA 01.71 \[1\]](#) for more information on conducted sensitivity measurements and cabling setups

TIS shall be fully measured as described above and calculated pursuant to [CTIA 01.20 \[4\]](#) for the 3 channels (low, middle and high) specified in [Table 2.3-3](#).

Receiver sensitivity testing on intermediate channels is not required by this test procedure.

## 2.4 OTA Reporting for Bluetooth Basic Rate TIS

Results shall be reported as specified below using the figures of merit given in *CTIA 01.20* [4]. [Table 2.4-1](#) contains the TIS test results for Bluetooth Basic Rate. Reports shall include results for free-space, head/hand and wrist-worn configurations (if applicable) across all channels measured.

Table 2.4-1 Bluetooth Basic Rate TIS Test Results

TIS								
Channel	Frequency (MHz)	FS	HL	HR	BHHL	BHHR	WL	WR
0	2402							
39	2441							
78	2480							

## Section 3 ZigBee (Informative)

Note: The use of "shall" or "must" in the test procedures listed herein is only used to indicate that the test purpose, procedure, and/or result may not be as expected if the specified "shall" or "must" item is not used or followed. As this Section is informative in nature, the use of "shall" or "must" in the test procedures is not meant to imply a specific requirement. Their use is meant to indicate instances where the test objectives of the recommended test procedures may not be achieved if these recommendations are not followed.

### 3.1 ZigBee TRP Test Procedure

The measurement site and DUT shall be configured as specified in *CTIA 01.71 [1]*. The transmit power level of the DUT to be used for TRP testing shall be at the level intended for the device to be used in the field, and subject to the specific limits the DUT was tested and approved for during regulatory testing (e.g., FCC).

- The DUT shall be tested in its intended mechanical mode and form factor in free space condition.
- It shall be declared which is the power mode: AC mains, barrel batteries (e.g., AA, AAA, CR2), and coin cell batteries (e.g., CR2032)
- Battery-powered devices should be able to complete the full TRP/TIS tests on 4 batteries or less.
- For TRP/TIS testing purposes DUTs should support non-sleepy mode, in order to minimize test times.
- Non-fixed antenna diversity behaves as one antenna.
- Test firmware running on DUT, which is added for testing purposes only and removed for production.

The communication module settings shall be as per Section 3.4.

1. Measure free space effective isotropic radiated power (EIRP) pattern.
2. Calculate TRP using EIRP measurements.
3. Repeat for at least the channels defined in Table 3.1-1 in which the DUT supports.

Table 3.1-1 Spectrum Analyzer Settings for Zigbee

Span	3 MHz
Resolution Bandwidth (RBW)	100 kHz
Video Bandwidth (VBW)	10 MHz
Sweep Time	100 ms
RMS Detector	Enabled
Data Points	501
Data Duration	1500 ms
Integrated Channel Power	Enabled
Attenuation	Auto
Channels: as defined in Section	Table V-2

Table 3.1-2 Zigbee Channel Settings

Channel	Frequency
0	868
1	906
4	912
7	918
10	924
11	2405
15	2425
20	2450
25	2475

To provide a consistent basis for comparison and a balance between setup efforts and actual test time the following channels have been selected as the minimum set of channels to be tested for TRP and TIS.

Additional channels as determined by the manufacturer (device, platform, model, or product) may be optionally tested as well. Only the bands supported by the device shall be tested (either in the 868 MHz, 915 MHz, and/or 2.4 GHz range).

As shown in [Figure 3.1-1](#), TRP measurements utilize the uplink path through the measurement antenna; measurements are performed on the spectrum analyzer. Testing is done for both vertical and horizontal polarization of the measurement antenna.

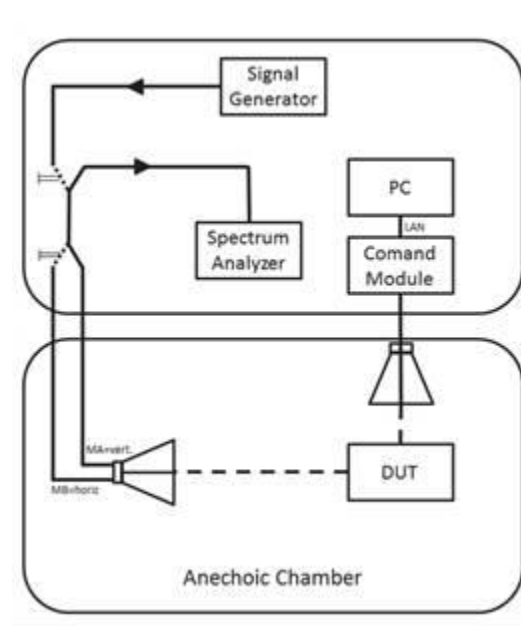

Figure 3.1-1 TRP Block Diagram Set Up for Zigbee

### 3.2 ZigBee TIS Test Procedure

The DUT shall be configured as specified in *CTIA 01.71* [1]. The DUT is placed in a free-space holder. Communication with the host controller is automatically established via a communication antenna inside the chamber. The DUT is brought to the required test channel and output power level through the host controller.

TIS measurements are performed using the Receive Signal Strength (RSS) method. The method shall use the following four steps using RSSI values:

1. RSS pattern measurements
2. RSS pattern linearization
3. Sensitivity search
4. TIS calculation

RSSI values are obtained through ZigBee host from the DUT measurement reports, the TIS test case flow is illustrated using the commands from [Section 3.4](#).

The Signal Generator: DUT shall receive output from a Signal Generator capable of generating digitally modulated radio frequency signals for band of operation.

The Signal Generator shall be configured to transmit a standard conforming signal and packet with an arbitrary payload and correct CRC with the following parameters:

Using the PSDU generation approach described in clause T.5 Test Case Command Flow

- Number of (PSDU) bits: 20x8
- Phase continuous bit pattern
- Modulation Specifics:
- Offset Quadrature Phase Shift Keying (O-QPSK)
- Pulse Shaping: Half Sine Pulse Shaping

Table 3.2-1 Zigbee Parameter Settings for RSS Method

Packets during fine steps	2500
RSS Measurement Packets	10
Packets during course step	25
Fine Step Size	0.5 dB
Non-protocol Packets	random # between 2500 and 3500
RSS Data Duration	1500 ms
Channels	Table V-2

1. Measure free space effective isotropic sensitivity (EIS) pattern, Adjust the downlink signal level until the PER is 0.04%. The downlink step size shall be no more than 0.5 dB when the downlink power is near sensitivity.
2. Calculate TIS using EIS measurements
3. Repeat for at least the channels defined in [Table 3.2-1](#) in which the DUT supports.

As shown in [Figure 3.2-1](#), TIS measurements utilize the downlink path from the ESG through the measurement antenna; measurement reports are recorded at the DUT in terms of RSSI. Testing is done for both vertical and horizontal polarization of the measurement antenna.

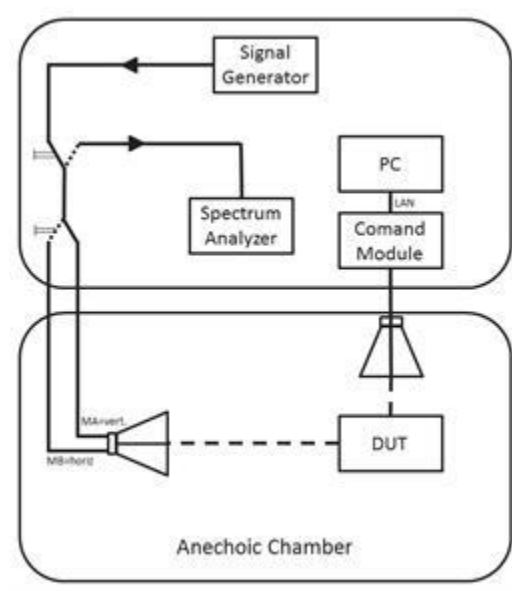

Figure 3.2-1 TIS Block Diagram Set Up for Zigbee

### 3.3 ZigBee Reporting the Results

This document provides details for test equipment and device manufacturers of the exact packets and contents exchanged over the air during a TRP/TIS performance test for ZigBee devices.

Commands are sent OTA between a command module and a DUT as per Section 3.4.

Table 3.3-1 Zigbee Total Radiated Power

Band	Ch.	Freq. (MHz)	Cond. Power (dBm)	TRP (dBm) FS	NHPRP $\pm 45^\circ$ (dBm) FS	NHPRP $\pm 30^\circ$ (dBm) FS
868 MHz	0	868				
915 MHz	1	906				
915 MHz	4	912				
915 MHz	7	918				
915 MHz	10	924				
2.4 GHz	11	2405				
2.4 GHz	15	2425				
2.4 GHz	20	2450				
2.4 GHz	25	2475				

Table 3.3-2 ZigBee Total Isotropic Sensitivity

Band	Ch.	Freq. (MHz)	Cond. Power (dBm)	TRP (dBm) FS	NHPRP $\pm 45^\circ$ (dBm) FS	NHPRP $\pm 30^\circ$ (dBm) FS
868 MHz	0	868				
915 MHz	1	906				
915 MHz	4	912				
915 MHz	7	918				
915 MHz	10	924				
2.4 GHz	11	2405				
2.4 GHz	15	2425				
2.4 GHz	20	2450				
2.4 GHz	25	2475				



### 3.4 ZigBee Command Module and Test Case Flow

This section contains a comprehensive list of all commands exchanged between the command module (CMD) and the DUT during TRP/TIS testing.

The contents of these commands fit in the PAYLOAD portion of the frame. Command IDs 240-250 are reserved.

PING

- COMMAND ID: 0x00
- DIRECTION: CMD->DUT
- PAYLOAD: [0xDE] [0xDE] [0x00] [0x00]
- UPON RECEIPT: DUT will send an ACK

ACK

- COMMAND ID: 0x01
- DIRECTION: DUT->CMD
- PAYLOAD: [0xDE] [0xDE] [0x00] [0x01]
- UPON RECEIPT: CMD will print indication of ACK received
- "ACK" (failure case - "NO ACK")

SET\_CHANNEL

- COMMAND ID: 0x02
- DIRECTION: CMD->DUT
- PAYLOAD: [0xDE] [0xDE] [0x00] [0x02] <channel:3> <channel:2>  
<channel:1> <channel:0>

- <channel> is a 4 byte octet, which includes both channel page and channel #

- UPON RECEIPT: DUT will set channel

GET\_CHANNEL\_RESPONSE

- COMMAND ID: 0x04
- DIRECTION: DUT->CMD
- PAYLOAD: [0xDE] [0xDE] [0x00] [0x0x04] <channel:3> <channel:2>  
<channel:1> <channel:0>

- <channel> is a 4 byte octet, which includes both channel page and channel #

- UPON RECEIPT: CMD will indicate which GET\_CHANNEL\_RESPONSE it received as a 4 byte octet

- channel]0x%x

SET\_POWER (for future revision/release)

- COMMAND ID: 0x05
- DIRECTION: CMD->DUT
- PAYLOAD: [0xDE] [0xDE] [0x00] [0x05] <mode:1> <mode:0> <power>

- <mode:1> Boolean switch for TX power amplifier: 0 disabled, 1 enabled

- <mode:2> Boolean switch for RX low power amplifier: 0 disabled, 1 enabled

- <power> DUT power in dBm (hexadecimal)

- UPON RECEIPT: DUT will set mode and power on the DUT

GET\_POWER

- COMMAND ID: 0x06
- DIRECTION: CMD->DUT
- PAYLOAD: [0xDE] [0xDE] [0x00] [0x06]
- UPON RECEIPT: DUT will send a GET\_POWER\_RESPONSE

GET\_POWER\_RESPONSE

- COMMAND ID: 0x07
- DIRECTION: DUT->CMD
- PAYLOAD: [0xDE] [0xDE] [0x00] [0x07] <power>
- UPON RECEIPT: CMD will indicate the GET\_POWER\_RESPONSE received

- mode]0x%2x[power]%x

STREAM

- COMMAND ID: 0x09

- DIRECTION: CMD->DUT
- PAYLOAD: [0xDE] [0xDE] [0x00] [0x09] < duration(ms):1> < duration(ms):0>
- UPON RECEIPT: DUT will start a modulated waveform stream and then stop stream at end of duration. This provides the capability to pulse the modulated waveform on and off for testing.

START\_RX\_TEST

COMMAND ID: 0x0A

- DIRECTION: CMD->DUT
- PAYLOAD: [0xDE] [0xDE] [0x00] [0x0A]
- UPON RECEIPT: DUT will clear totalPackets, protocolPackets, totalLQI, and totalRSSIMagnitude counters and begin incrementing statistics

END\_RX\_TEST

- COMMAND ID: 0x0B
- DIRECTION: CMD->DUT
- PAYLOAD: [0xDE] [0xDE] [0x00] [0x0B]
- UPON RECEIPT: DUT will stop incrementing statistics and send a REPORT

REPORT

- COMMAND ID: 0xC
- DIRECTION: DUT->CMD
- PAYLOAD: [0xDE] [0xDE] [0x00] [0xC] <totalPackets:3> <totalPackets:2> <totalPackets:1> <totalPackets:0> <protocolPackets:3> < protocolPackets:2> < protocolPackets:1> < protocolPackets:0> <totalLqi:3> < totalLqi:2> < totalLqi:1> < totalLqi:0> <totalRssiMagnitude:3> < totalRssiMagnitude:2> < totalRssiMagnitude:1> < totalRssiMagnitude:0>

- UPON RECEIPT: CMD will print statistics
- o"[total]0x%x%x%x%x [protocol]0x%x%x%x%x  
[totalLqi]0x%x%x%x%x [totalRssiMgnitude]0x%x%x%x%x"
- Currently:
  - <totalPackets> field is ignored
  - Assumes no RSSI values measured that are greater than zero dBm
  - <totalRssiMagnitude> is the sum of inverted (i.e., absolute value) RSSI values (e.g., measured value of -87 dBm will be reported as <totalRssiMagnitude> = "87")
  - <totalLqi> field is ignored

## REBOOT

- COMMAND ID: 0x0D
- DIRECTION: CMD->DUT
- PAYLOAD: [0xDE] [0xDE] [0x00] [0x0D]
- UPON RECEIPT: DUT will reboot

## GET\_REBOOT\_BYTE\_RESPONSE

- COMMAND ID: 0x10
- DIRECTION: DUT->CMD
- PAYLOAD: [0xDE] [0xDE] [0x00] [0x0x10] <rebootByte>
- UPON RECEIPT: CMD will print indication of ACK receive
- "[rebootByte]0%x"

## GET\_HARDWARE\_VERSION

- COMMAND ID: 0x11
- DIRECTION: CMD->DUT
- PAYLOAD: [0xDE] [0xDE] [0x00] [0x0x11]
- UPON RECEIPT: DUT will send a GET\_HARDWARE\_VERSION\_RESPONSE

## GET\_HARDWARE\_VERSION\_RESPONSE

- COMMAND ID: 0x12
  - DIRECTION: DUT->CMD
  - PAYLOAD: [0xDE] [0xDE] [0x00] [0x0x12] <hardware version>
  - <hardware version> is the same Unsigned 8-bit integer (HWVersion) defined in the ZCL
  - UPON RECEIPT: CMD will print indication of GET\_HARDWARE\_VERSION\_RESPONSE it received
  - [hardware version] char %x
- GET\_SOFTWARE\_VERSION
- COMMAND ID: 0x13
  - DIRECTION: CMD->DUT
  - PAYLOAD: [0xDE] [0xDE] [0x00] [0x0x13]
  - UPON RECEIPT: DUT will send a GET\_SOFTWARE\_VERSION\_RESPONSE
- GET\_SOFTWARE\_VERSION\_RESPONSE
- COMMAND ID: 0x14
  - DIRECTION: DUT->CMD
  - PAYLOAD: [0xDE] [0xDE] [0x00] [0x0x14] <software version>
  - <software version> is an Unsigned 8-bit integer indicating the version of the test firmware
  - UPON RECEIPT: CMD will print indication of GET\_SOFTWARE\_VERSION\_RESPONSE it received
  - [software version] char %x

#### CMD Application Commands

- All commands to be issued on the CMD node - these will be called via test script
- The CMD node is the target for 'l'xxx (local) commands
- The DUT node is the target for 'r'xxx (remote) commands
- General commands are convenient abstractions for syncing the CMD

and the DUT nodes

- The sole purpose of the reboot Byte is acting as a way in which a reboot can be verified - the reboot Byte variable will be reverted to the default after being changed
- The "custom find" command is a mechanism in which a "lost" DUT can be forced to a particular channel
- Command will accept both decimal and noted hex argument

"custom rping"

- CMD will send PING
- If PING is received, DUT will send ACK
- CMD will print "ACK" is ACK received before timeout
- CMD will print "NO ACK" is timeout reached before ACK received

"custom lpingtimeout <timeout(ms):1> <timeout(ms):0>"

- Will change ping timeout on CMD (default is 500 ms)

"custom set channel <channel:3> <channel:2> <channel:1> <channel:0>"

- CMD will send SET\_CHANNEL to DUT
- CMD will set channel
- CMD will send PING to DUT (refer to "custom rping")

"custom lsetchannel <channel:3> <channel:2> <channel:1> <channel:0>"

- CMD will set channel

"custom rsetchannel <channel>"

- CMD will send SET\_CHANNEL to DUT

"custom lgetchannel"

- CMD will return channel

"custom lsetpower <mode:1> <mode:0> <power>"

- CMD will set power

"custom rsetpower <mode:1> <mode:0> <power>" (for future revision/release)

- CMD will send SET\_POWER to DUT

"custom lgetpower"

- CMD will return power

"custom rgetpower"

- CMD will send GET\_POWER to DUT
- DUT will send GET\_POWER\_RESPONSE to CMD

"custom rstream <duration(ms):1> <duration(ms):0>"

- CMD will send STREAM to DUT
- DUT will transmit a modulated waveform for the duration specified

"custom rstart"

- CMD will send START\_RX\_TEST to DUT
- DUT will clear totalPackets, protocolPackets, totalLQI, and totalRSSIMagnitude counters
- DUT will begin incrementing statistics

"custom rend"

- CMD will send END\_RX\_TEST to DUT
- DUT will stop incrementing statistics
- DUT will send REPORT to CMD

"custom reboot"

- CMD will send REBOOT to DUT
- CMD will reboot

"custom lreboot"

- CMD will reboot

"custom rreboot"

- CMD will send REBOOT to DUT

"custom find <channel>"

- CMD will send SET\_CHANNEL to DUT on all channels
- CMD will set channel to channel passed to the function
- CMD will send PING to DUT (refer to "custom rping")

"custom rhardwareversion"

- CMD will send GET\_HARDWARE\_VERSION to DUT
- DUT will send GET\_HARDWARE\_VERSION\_RESPONSE to CMD

"custom rsoftwareversion"

- CMD will send GET\_SOFTWARE\_VERSION to DUT
- DUT will send GET\_SOFTWARE\_VERSION\_RESPONSE to CMD



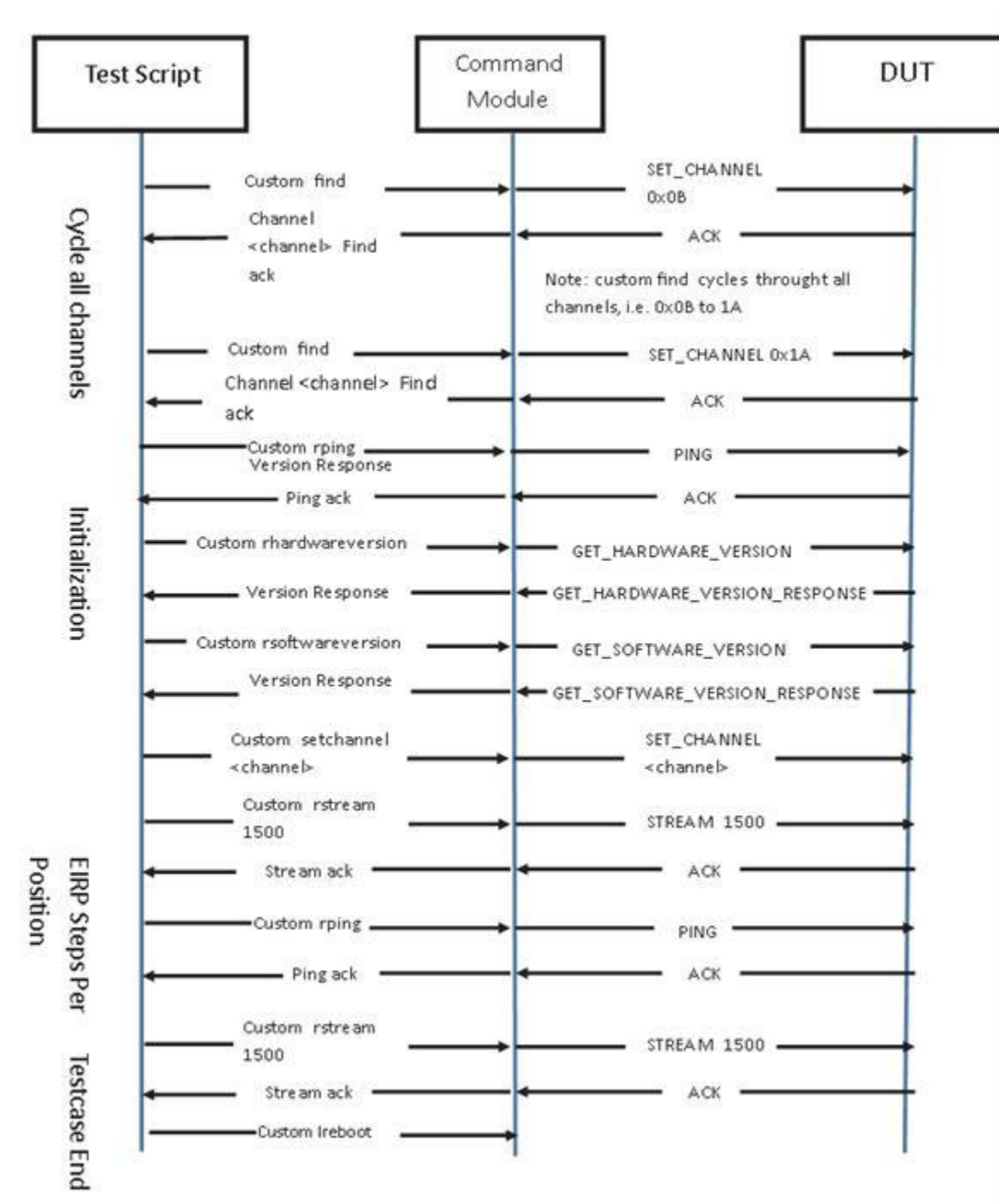

Figure 3.4-1 Zigbee Total Radiated Power Test Case Command Flow

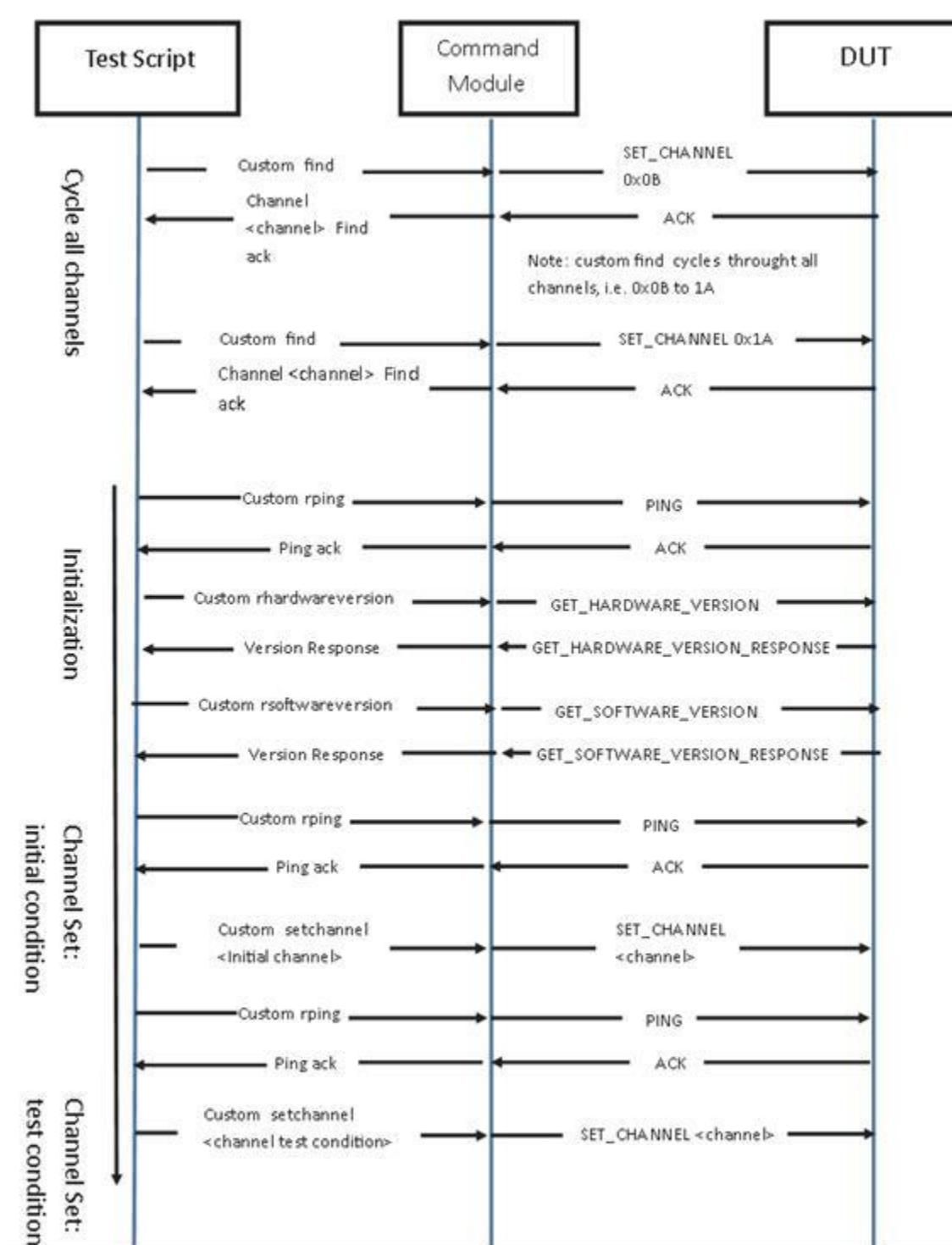

Figure 3.4-2 Zigbee Total Isotropic Sensitivity Test Case Command Flow

## Section 4 Bluetooth Low Energy (LE) (Informative)

Note: The use of "shall" or "must" in the test procedures listed herein is only used to indicate that the test purpose, procedure, and/or result may not be as expected if the specified "shall" or "must" item is not used or followed. As this Section is informative in nature, the use of "shall" or "must" in the test procedures is not meant to imply a specific requirement. Their use is meant to indicate instances where the test objectives of the recommended test procedures may not be achieved if these recommendations are not followed.

The device shall transmit Bluetooth LE advertisements continuously, at intervals up to 10 seconds (per BT SIG), and it shall not transmit other RF signals in the 2.4 GHz band. The interval between Bluetooth LE advertisements may be and may need to be modified to optimize OTA test time and is recommended to be about 100ms to achieve reasonable OTA test times. Advertising intervals shorter than 100ms may be used and will decrease test times, however care should be used that the device does not misbehave and that the test system can properly handle the shorter advertising interval. Sleep modes in the device may be and should be disabled to avoid interruptions in the OTA testing.

### 4.1 Bluetooth LE TRP Test Procedure

This procedure is intended for Bluetooth LE DUT capable of Broadcaster or Peripheral operation.

The DUT shall be configured as specified in *CTIA 01.71* [1]. The power radiated by the DUT shall be measured using a calibrated and accurate RF measuring instrument capable of measuring peak and average power across bursts. Instrument settings shall be equivalent to the Bluetooth SIG recommendations summarized in [Table 4.1-1](#). See *Bluetooth Core Specification* [6] version 5.2 [Vol 0].

Table 4.1-1 RF Instrument Measurement Settings

Frequency span	Zero span
Resolution BW	3 MHz
Video BW	3 MHz
Detector	Peak
Sweep time	10 ms
Trigger	RF (trigger on rising edge)
VSA Measurements	Sample Rate 40M sample/sec or higher

The DUT shall be configured for one of the modes shown in [Table 4.1-2](#).

Table 4.1-2 Modes for Bluetooth LE Transmitter Test

DUT Mode	See <i>Bluetooth Core Specification</i> [6] version 5.2 [Vol 0].
Broadcast Mode	9.1.1
Limited Discoverable mode	9.2.3
General Discoverable mode	9.2.4

Test procedure:

1. Configure RF instrument settings equivalent to those shown in [Table 4.1-1](#).
2. Configure DUT to one of the modes defined in [Table 4.1-2](#).
3. Perform this procedure on all advertising channels supported by the DUT (See [Table 4.1-3](#)).
4. Average RF power over at least 20% to 80% of the duration of the burst as defined by Bluetooth SIG PHY test specification for Bluetooth low energy.
5. Average RF power over at least 5 packets on each channel.

Table 4.1-3 Bluetooth LE Test Channels

Channel	Frequency (Mhz)
37	2402
38	2426
39	2480

Hand phantom only, wrist-worn and/or free-space testing shall be conducted based on device type, as specified in *CTIA 01.01* [5]. Refer to *CTIA 01.71* [1] for head/hand positioning requirements and for wrist-worn positioning requirements.

#### 4.1.1 OTA Reporting for Bluetooth LE TRP

Results shall be reported as specified below using the figures of merit given in *CTIA 01.01* [5].

Table 4.1.1-1 contains the OTA test results for Bluetooth LE. Reports shall include results for free-space, hand and wrist worn configurations (if applicable) across all channels measured with the DUT antenna extended and retracted (if applicable).

Table 4.1.1-1 Bluetooth LE TRP Test Results

TRP						
Channel	Frequency (MHz)	FS	HL	HR	WL	WR
37	2402					
38	2426					
39	2480					

## 4.2 Bluetooth LE TIS Test Procedure

Bluetooth LE Receiver Sensitivity measurements shall be performed using a communication tester capable of acting as a Bluetooth LE Central Device Simulator to determine the DUT's receiver sensitivity. Receiver sensitivity is defined using the recommendation in Bluetooth SIG specification as the forward-link power resulting in 0.1% Bit Error Rate (BER) with intentionally degraded "Dirty Packets". Refer to *CTIA 01.71 [1]* for set-up illustrations. See *Bluetooth Core Specification [6]* version 5.2 [Vol 0].

This procedure requires that the Bluetooth LE DUT be capable of Peripheral operation defined in [Table 4.2-1](#).

TIS measurements require a large number of results and test speed is important. Performing a Bluetooth SIG measurement at each spherical location would take a prohibitive amount of test time, so a two-step method is implemented that provides faster, but equivalent results:

1. Perform a TIS measurement using "Fast PER" sensitivity measurements
2. Perform a Single-Point Offset Test between the "Fast PER" sensitivity and the Bluetooth LE receiver sensitivity as defined by Bluetooth SIG.
3. Only the TIS based on Bluetooth LE receiver sensitivity as defined by Bluetooth SIG shall be reported.

The conducted sensitivity of the DUT shall also be measured at the antenna connector, if available, at all applicable frequencies. It is preferable that the DUT be the same as utilized for the TIS measurements. However, if the DUT does not readily support an antenna port for conducted measurements, a separate modified DUT may be provided for all conducted measurements. If no connector is available, the conducted sensitivity measurement is not required. Ideally, the sensitivity measurement will be performed with the same instrumentation in an equivalent configuration in order to minimize the measurement uncertainty involved. A different sensitivity measurement device may be used as long as any differences in absolute measurement accuracy are accounted for, either in corrections to the recorded sensitivity level or increased reported measurement uncertainty for the conducted measurement. Refer to *CTIA 01.71 [1]* for more information on conducted sensitivity measurements and cabling setups.

Table 4.2-1 Modes for Bluetooth LE Receiver Test

DUT Mode	Bluetooth SIG Reference
Limited Discoverable mode	9.2.3
General Discoverable mode	9.2.4

The EIS for the “Fast PER” sensitivity shall be determined by following the procedures in Section 4.2.1. The EIS results for each test channel can then be integrated to give a single figure of merit referred to as Total Isotropic Sensitivity (TIS). The EIS for the Bluetooth LE according to Bluetooth SIG shall be determined by following the procedures in Section 4.2.2.

Hand phantom only, wrist-worn and/or free-space testing shall be conducted based on device type, as specified in *CTIA 01.01* [5]. Refer to *CTIA 01.71* [1] for head/hand positioning requirements and for wrist-worn positioning requirements.

Receiver sensitivity testing on intermediate channels is not supported nor required by this test procedure as it is limited to testing the advertising channels.

#### 4.2.1 Test Procedure for Fast PER

1. Configure the DUT for BLE communication so that it is transmitting advertising packets on one of the advertising channels that the DUT supports (See [Table 4.1-3](#)). See [Table 4.2-1](#).
2. Perform a single error measurement on the target channel:
  - a. When the Simulator receives an advertisement packet from the DUT on an advertising channel, it shall transmit a Scan\_Request message to the DUT on the appropriate channel.
  - b. If DUT receives and decodes the Scan\_Request message correctly it will transmit a Scan\_Response message. The simulator will receive and record this as a non-error packet on that channel. Care must be taken to ensure that the Scan\_Response message is received correctly by the Simulator.
  - c. If DUT does not receive or does not decode the Scan\_Request message correctly it will not transmit a Scan\_Response message and the simulator will record this as an error packet on that channel.
3. Adjust the transmit RF level of the Simulator and repeat step 2. The RF transmit level should be selected to create a PER distribution curve near the 50% PER point. Step sizes should be 0.25 dB near the 50% point. After 200 packets (minimum), estimate 50% PER point based on PER distribution. If necessary, use more packets to ensure results are repeatable within 0.5 dB.
4. Record this level as the “Fast PER Receiver Sensitivity”.

#### 4.2.2 Test Procedure for BLE sensitivity per Bluetooth SIG

1. Repeat procedure in S.2.1 with the following changes
  - a. Target PER is 15.5%.
  - b. Packets must have Dirty Packet impairment applied (See *Bluetooth Core Specification* [6] version 5.2 [Vol 0].)
  - c. Search algorithm must use 1500 packets per level (See *Bluetooth Core Specification* [6] version 5.2 [Vol 0].)

- d. Record this level as the Bluetooth LE receiver sensitivity.

#### 4.2.3 OTA Reporting for Bluetooth LE TIS

Results shall be reported as specified below using the figures of merit. [Table 4.2.3-1](#) contains the TIS test results for Bluetooth Low Energy. Reports shall include results for free-space, hand and wrist-worn configurations (if applicable) across all channels measured.

Table 4.2.3-1 Bluetooth LE TIS Test Results

TIS						
Channel	Frequency (MHz)	FS	HL	HR	WL	WR
37	2402					
38	2426					
39	2480					

## Appendix A Revision History

Date	Version	Description
February 2022	4.0.0	Initial release
December 2022	5.0.0	No changes in this release.
March 2023	6.0.0	No changes in this release.