



Test Plan for RF Performance Evaluation of Wi-Fi® Mobile Converged Devices

Version 7.0.0

November 2024

© 2006 - 2024 CTIA Certification and Wi-Fi Alliance. All Rights Reserved.

Any reproduction, modification, alteration, creation of a derivative work, or transmission of all or any part of this publication ("Test Plan"), in any form, by any means, whether electronic or mechanical, including photocopying, recording, or via any information storage and retrieval system, without the prior written permission of CTIA Certification and Wi-Fi Alliance, is unauthorized and strictly prohibited by federal copyright law. This Test Plan is solely for use within the CTIA Certification and Wi-Fi Alliance certification programs. Any other use of this Test Plan is strictly prohibited unless authorized by CTIA Certification and Wi-Fi Alliance, or its assigns, in writing. This Test Plan is provided on an "as is basis."

Use Instructions

All testing to this test plan must be conducted in a CTIA Certification and Wi-Fi Alliance Authorized Test Lab.

This may be accomplished in one of three ways:

1. As part of a PTCRB certification request submitted at <https://www.ptcrb.com/>
2. By submitting an OTA Test Plan use request at <https://certify.ctiacertification.org/>
3. By completing a Wi-Fi Alliance CWG test application at <https://www.cert.wi-fi.org/>

CTIA Certification

1400 16th Street, NW
Suite 600
Washington, DC 20036 USA

+1.202.785.0081

programs@ctiacertification.org
ctiacertification.org/test-plans/

Wi-Fi Alliance

Quarry Oaks 1, 10900-A Stonelake Boulevard
Suite 195
Austin, TX 78759 USA

+1.512.498.9434

support@wi-fi.org
www.wi-fi.org

Acknowledgements

This test plan was created by the wireless industry with input from the following companies and their representatives

Company, Representative	Company, Representative
Apple: Kevin Camilleri, Diego Hernandez, Taeho Park, Wisuit Sinsathitchai, Istvan Szini	MultiTech Systems: Jody Lanes
AT&T: Jason Brown, Sungmi Choi, Scott Prather	MVG: John Estrada, Kim Rutkowski, Alessandro Scannavini
Anritsu: Charles Wright	NEC: Sanjay Wadhwa
Blackberry: Michael Montemurro	Nokia Corp.: Karthik Babu Adappa Laxmi, Alan Ewing, Randy Leenerts, Kevin Li, Steve Wilhoff
CETECOM, Inc: Lothar Schmidt	Philips Semiconductor: Steve Shearer
Cisco: Jae il Choi, Sam Kim	PCTEST Engineering Lab, LLC: Ron Borsato, Matt Smith
CTTL China Telecommunication Technology Labs: Siyang Sun	Rohde & Schwarz: David Connolly, Christoph Gagern, Thorsten Hertel, Alex Tkatch, Lisa Ward
DEKRA: Lorien Chang	Samsung: Usman Aurakzai, Kwangmin Choi, Chirag Panchal, James White
Dell: Johnny Gutierrez, Justin Harbour, Elvis Yen	SGS: Jason Bartosch, Peter Liao, Nicky (Ho) You
DSP Group: Graham Smith	Spirent Communications: Ron Borsato
ETS-Lindgren: Michael Foegelle, Edwin Mendivil	Sporton: Lorien Chang, Jerry Fu, Alexander Ho, Ace Liu, Will Ni, Elvis Yen
Google, LLC: Kevin Li	Telecommunications Metrology Center of China Ministry of Information Industry: Heather Gao
Intel Corp.: Hassan Yaghoobi	T-Mobile: Alex Tkatch
Ixia: Larry Green	UL Verification Services: Ekta Budhbhatti
Keysight Technologies: Moray Rumney	vivo Mobile Communications: Xing Dai, Benny Dong; Ruixin Wang
Microsoft: Kevin Li	Wi-Fi Alliance: David Baczewski, Lakshmi Narayana Mukkapati, Nick Sargologos, Jun Tian, Peng Yan
Motorola Mobility: Paul Moller, Istvan Szini	

Table of Contents

Section 1	Introduction.....	7
1.1	Background.....	7
1.2	Scope.....	7
1.3	Purpose	7
1.4	References	8
1.5	Test Nomenclature Overview	9
1.5.1	Conducted RF Tests.....	9
1.5.2	Radiated RF Tests.....	9
1.5.3	Desensitization Tests.....	9
1.6	Baseline Methodology	9
1.6.1	Measurement Techniques and Test Methodologies	9
1.6.2	Measurement Uncertainty	9
1.6.3	Minimum Measurement Distance	10
1.6.4	Quiet Zone Test Frequencies	10
1.7	Form Factor Submission for Self-contained Wi-Fi/Mobile Modules	10
1.8	List of Acronyms and Definitions	11
Section 2	Test Conditions and Device Configuration.....	13
2.1	Cellular and Wi-Fi Modes	13
2.2	Wi-Fi Mode	13
Section 3	Conducted Measurements.....	15
3.1	Wi-Fi Conducted RF Power Output and Receiver Sensitivity Tests	15
3.1.1	Test Purpose	15
3.1.2	Test Setup	15
3.1.3	Test Point Parameters.....	15
3.1.4	Test Procedure for Output Power Level	17
3.1.5	Test Procedure for Receiver Sensitivity	19
3.1.6	Results	19
Section 4	Radiated Measurements	20
4.1	Wi-Fi Total Radiated Measurements (TRP/TIS).....	20
4.1.1	Test Purpose	20
4.1.2	Test Setup	20
4.1.3	Test Point Parameters.....	21
4.1.4	Test Procedure for Total Radiated Power Measurement.....	23
4.1.5	Test Procedure for Total Isotropic Sensitivity Measurement.....	24
4.1.6	Results	24
4.2	Wi-Fi Desensitization Measurements with Cellular Transmitter ON	24

4.2.1	Test Purpose	24
4.2.2	Test Setup	24
4.2.3	Test Point Parameters	25
4.2.4	Test Procedures for Wi-Fi Radio Desensitization	26
4.2.5	Wi-Fi Radio Desensitization by Closest Cellular Uplink Frequency	26
4.2.6	Wi-Fi Radio Desensitization by Cellular Radio Uplink Harmonics	31
4.2.7	Results	37
4.3	Cellular Desensitization Measurements with Wi-Fi transmitter ON	38
4.3.1	Test Purpose	38
4.3.2	Test Setup	38
4.3.3	Test Point Parameters	39
4.3.4	Test Procedure for RATs with Free-Space TIS Limits	39
4.3.5	Test Procedure for RATs without Free-Space TIS Limits	40
4.3.6	VOID	40
4.3.7	Error Rate Measure	40
4.3.8	Results	41
Appendix A	Test Reports	42
A.1	Wi-Fi Conducted Tests	42
A.2	Total Radiated Power (TRP) and Total Isotropic Sensitivity (TIS) for 2.4 GHz 802.11b, 802.11g, 802.11n and 802.11ax	48
A.3	Total Radiated Power (TRP) and Total Isotropic Sensitivity (TIS) for 5 GHz 802.11a, 802.11n and 802.11ax	49
A.4	Total Radiated Power (TRP) and Total Isotropic Sensitivity (TIS) for 6 GHz 802.11ax	50
A.5	Wi-Fi Desensitization Measurements (with Cellular Transmitter On)	51
A.6	Cellular Desensitization Measurements (with Wi-Fi Transmitter On)	52
A.7	Machine Readable Report	54
Appendix B	Handheld Device Testing Configurations	57
Appendix C	Test Channels that Require Testing, but are not Defined in the CTIA Certification OTA Test Plan	58
Appendix D	Notebook and Tablet Requirements	59
D.1	Parent/Child Relationships	59
D.2	Parent/Child Antenna Subsystem Considerations	59
D.3	Test Configurations and Setup Procedures	59
Appendix E	Wi-Fi-LTE Emulator Test Equipment Notes when Testing DUTs that Support LTE Band 40 or 41 (Informative)	60
Appendix F	Table of Wi-Fi Radio Channels Interfered by Cellular Radio Harmonics	62
Appendix G	Special Test Requirements (Informative)	92
Appendix H	Revision History	93

List of Figures

Figure 3.1.2-1 Block Diagram for Wi-Fi Conducted Measurement.....	15
Figure 4.1.2-1 Simplified Block Diagram Showing a Common Configuration for TRP/TIS Measurement	20
Figure 4.1.2-2 Simplified Block Diagram Showing a Configuration for TRP Measurement	21
Figure 4.1.2-3 Simplified Block Diagram Showing a Configuration for TIS Measurement	21
Figure 4.2.2-1 Simplified Block Diagram Showing a Common Configuration for Wi-Fi Desensitization Measurements.....	25
Figure 4.2.2-2 Simplified Block Diagram Showing Another Common Configuration for Wi-Fi Desensitization Measurements	25
Figure 4.3.2-1 Example Test System Configuration for Cellular Desensitization Measurements	38
Figure E-1 LTE Band 40 and Wi-Fi 2.4 GHz Frequency Diagram.....	60
Figure E-2 LTE Band 41 and Wi-Fi 2.4 GHz Frequency Diagram.....	60
Figure E-3 Wi-Fi Emulator Test Equipment Verification Test Setup (to Test the LTE Base Station	61
Figure E-4 Example Test System Diagram (Only for Wi-Fi Desensitization or LTE Cellular Desensitization Tests, if the DUT Supports LTE Band 40).....	61

List of Tables

Table 3.1.3-1 Measurement Frequencies for Conducted Tests	16
Table 3.1.3-2 TX Test Data Rates for Conducted Testing.....	16
Table 3.1.3-3 RX Test Data Rates for Conducted Testing	17
Table 3.1.4-1 Parameter Settings for Output Power Level Test	18
Table 3.1.5-1 Parameter Settings for Receiver Sensitivity Test	19
Table 4.1.3-1 TIS/TRP Measurement Channels for IEEE 802.11a, n and ax Supported Frequency Ranges	22
Table 4.1.3-2 Receiver.....	23
Table 4.1.5-3 Parameter Settings for Receiver Sensitivity Test	24
Table 4.2.4-1 Parameter Settings for Wi-Fi Radio Desensitization Test	26
Table 4.2.5-1 Closest Channel Combinations	28
Table 4.2.6-1 Desensitization Cases	32
Table 4.3.3-1 Middle Channels for Wi-Fi Frequency Ranges in 5 GHz for TIS Cellular Desensitization ..	39

Table 4.3.3-2 Middle Channels for Wi-Fi Frequency Ranges in 6 GHz for TIS Cellular Desensitization .. 39

Table A-1 Sample Summation 42

Table A.1-1 Conducted RF Power Output and Receiver Sensitivity Results 42

Table A.2-1 TRP for 2.4 GHz 802.11b/g/n/ax..... 48

Table A.2-2 TIS for 2.4 GHz 802.11b/g/n/ax..... 48

Table A.3-1 TRP for 5 GHz 802.11a/n/ax 49

Table A.3-2 TIS for 5 GHz 802.11a/n/ax..... 49

Table A.4-1 TRP for 6 GHz 802.11ax 51

Table A.4-2 TIS for 6 GHz 802.11ax..... 51

Table A.5-1 Wi-Fi Radio Desensitization by Closest Cellular Uplink Frequency 51

Table A.5-2 Wi-Fi Radio Desensitization by Cellular Radio Uplink Harmonics 802.11b/g/n/a/ax 52

Table A.6-1 Cellular Desensitization Test Results for 802.11b Operation (Wi-Fi 2.4 GHz Band) with Cellular Free-Space Limits 53

Table A.6-2 Cellular Desensitization Test Results for 802.11a Operation with Cellular Free-Space Limits 53

Table A.6-3 Cellular Desensitization Test Results for 802.11b Operation (Wi-Fi 2.4 GHz Band) without Cellular Free-Space Limits 53

Table A.6-4 Cellular Desensitization Test Results for 802.11a Operation without Cellular Free-Space Limits 54

Table B.1-1 Device Testing Applicability Matrix..... 57

Table D.3-1 Test Applicability Matrix 59

Section 1 Introduction

1.1 Background

Increasingly, the wireless market is seeing converged devices that incorporate both cellular and wireless local area network (WLAN or Wi-Fi®) functionality. Due to the many potential applications and deployment scenarios that converged devices may ultimately function in, operators and device vendors are interested in a uniform and standard way for profiling the RF performance of the devices and associated test methodology. With this standard approach, equipment designers, system operators, and RF engineers have the flexibility to determine their own appropriate RF performance criteria based on their engineering assessments and can easily identify equipment that is suitable for each deployment and application.

1.2 Scope

This test document specifies test methodologies and performance criteria for the RF performance evaluation of Wi-Fi mobile converged devices. The scope of testing includes Handheld, self-contained Wi-Fi/Mobile Module, Access Point, Notebook and Tablet devices that support IEEE 802.11a, 802.11b, 802.11g, 802.11n, 802.11ac [9] and/or 802.11ax [16] as well as cellular technologies. Support for IEEE 802.11 standards shall be confirmed through Wi-Fi Alliance® baseline certification [17]—that is, devices tested using this test plan shall first be Wi-Fi CERTIFIED™ for IEEE 802.11a, 802.11b, 802.11g, 802.11n, 802.11ac and/or 802.11ax [16]. Cellular technologies include GSM, UMTS (WCDMA), LTE and NR.

This document relies on the measurement techniques and methodologies within the *CTIA Certification Test Plan for Wireless Device Over-the-Air Performance* [1] (referred to in this document hereafter as “CTIA Certification OTA Test Plan”).

1.3 Purpose

The purpose of this document is to define the test methodology for the RF testing of Wi-Fi mobile converged devices and to specify the test conditions for each test case. The testing covers client devices and access points and specifies conducted as well as radiated tests.

1.4 References

When referencing other CTIA OTA documents, please use the latest V7.0.x.

- [1] “CTIA Certification Test Plan for Wireless Device Over-the-Air Performance Suite”, CTIA Certification, <https://ctiacertification.org/test-plans/>
- [2] “CTIA 01.01, Test Scope, Requirements, and Applicability”, CTIA Certification, <https://ctiacertification.org/test-plans/>
- [3] “CTIA 01.20, Test Methodology, SISO, Anechoic Chamber”, CTIA Certification, <https://ctiacertification.org/test-plans/>
- [4] “CTIA 01.50, Wireless Technology, 3GPP Radio Access Technologies”, CTIA Certification, <https://ctiacertification.org/test-plans/>
- [5] “CTIA 01.70, Measurement Uncertainty”, CTIA Certification, <https://ctiacertification.org/test-plans/>
- [6] “CTIA 01.71, Device Setup and Positioning Guidelines”, CTIA Certification, <https://ctiacertification.org/test-plans/>
- [7] “CTIA 01.72, Near-Field Phantoms”, CTIA Certification, <https://ctiacertification.org/test-plans/>
- [8] “CTIA 01.73, Supporting Procedures”, CTIA Certification, <https://ctiacertification.org/test-plans/>
- [9] “IEEE Std. 802.11™-2020 IEEE Standard for Information technology--Telecommunications and information exchange between systems Local and metropolitan area networks-- Specific requirements Part 11: Wireless LAN Medium Access Control (MAC) and Physical Layer (PHY) Specifications”, December 2020 IEEE, https://standards.ieee.org/standard/802_11-2020.html
<http://standards.ieee.org/about/get>
- [10] “User Equipment (UE) / Mobile Station (MS) Over The Air (OTA) antenna performance; Conformance testing (3GPP TS 34.114)”, Latest Revision, 3GPP, <http://www.3gpp.org/DynaReport/34114.htm>
- [11] Check the product’s Wi-Fi CERTIFIED Interoperability Certificate at:
<https://www.wi-fi.org/product-finder>
- [12] RFC 792 “Internet Control Message Protocol”, IETF, September 1981, <https://tools.ietf.org/html/rfc792>
- [13] RFC 1122 “Requirements for Internet Hosts – Communication Layers”, IETF, October 1989, <https://tools.ietf.org/html/rfc1122>
- [14] OPERATION IN U-NII BANDS –802.11 CHANNEL PLAN (§15.407), FCC, [905462 D06 802 11 Channel Plans New Rules v02](https://www.fcc.gov/05462D0680211ChannelPlansNewRulesv02)
- [15] 5 GHz RLAN; Harmonised Standard covering the essential requirements of article 3.2 of Directive 2014/53/EU, ETSI, [ETSI EN 301 893 V2.1.1 \(2017-05\)](https://www.etsi.org/standards-store/301893)
- [16] “IEEE Std 802.11ax™-2021, IEEE Standard for Information Technology— Telecommunications and Information Exchange between Systems Local and Metropolitan Area Networks— Specific Requirements, Part 11: Wireless LAN Medium Access Control (MAC) and Physical Layer (PHY) Specifications, Amendment 1: Enhancements for High-Efficiency WLAN”, February 2021.

[17] Wi-Fi Alliance certification Test plans: <https://www.wi-fi.org/members/certification-programs/wi-fi-alliance-test-plans>

[18] “CTIA 01.03, Reporting Tables,” CTIA Certification, <https://ctiacertification.org/test-plans/>

1.5 Test Nomenclature Overview

1.5.1 Conducted RF Tests

Conducted tests are those RF Tests where the test equipment is connected to the antenna connector of the device under test by co-axial cables. These tests are formulated to measure basic RF performance such as sensitivity and transmit power.

1.5.2 Radiated RF Tests

Radiated tests are those RF Tests that are carried out in a test environment which meets the requirements of the *CTIA Certification Test Plan for Wireless Device Over-the-Air Performance* [1]. These include Wi-Fi radiated TX Power (TRP), Wi-Fi radiated Receive Sensitivity (TIS), Radiated Receive Sensitivity of Wi-Fi with cellular active, and Radiated Receive Sensitivity of the cellular radio(s) with Wi-Fi active.

1.5.3 Desensitization Tests

Desensitization tests measure the impact that the cellular radio, when transmitting, has upon Wi-Fi reception and vice-versa. These tests are performed as radiated tests according to Device Testing Configurations.

1.6 Baseline Methodology

1.6.1 Measurement Techniques and Test Methodologies

TRP and TIS in cellular mode are defined in both the *CTIA Certification Test Plan for Wireless Device Over-the-Air Performance* [1] and *User Equipment (UE) / Mobile Station (MS) Over The Air (OTA) antenna performance; Conformance testing* (3GPP TS 34.114) [10].

This document relies on the measurement techniques and methodologies within the *CTIA Certification Test Plan for Wireless Device Over-the-Air Performance* [1] developed specifically for the purposes of measurement of radiated transmit power and sensitivity. The techniques specified in the *CTIA Certification Test Plan for Wireless Device Over-the-Air Performance* [1] shall be used as the baseline test methodologies for all tests in here, unless otherwise stated. This document contains information to expand the *CTIA Certification Test Plan for Wireless Device Over-the-Air Performance* [1] for use with 802.11 a, b, g, n, ac and ax devices. Since the physical layer characteristics of 802.11n at 5 GHz band and 802.11ac are the same for the specified test conditions, for the purposes of this test plan, an 802.11ac device shall be tested as an 802.11n device in 5 GHz band. In the test procedures described below, 802.11ac devices shall be tested following the same test procedures and conditions as an 802.11n device. These sections are meant to clarify for the user how the *CTIA Certification OTA Test Plan* [1] can be utilized for Wi-Fi enabled converged devices.

1.6.2 Measurement Uncertainty

Refer to *CTIA 01.20* [3] Section 5 for the uncertainty budget tables for TRP and TIS. The lab shall report their estimated measurement uncertainty for both the 2.4, 5 GHz and 6 GHz bands. For the 6 GHz band, the measurement uncertainty of 5 GHz is applicable until the measurement uncertainty analysis for 6 GHz is available.

1.6.3 Minimum Measurement Distance

This section describes the minimum measurement distance, R, which the Far-Field test site shall provide. The measurement distance is defined as the distance from the center of rotation of the DUT to the phase center (alternatively, if not accurately known, the nearest point) of the Measurement Antenna.

For Cellular minimum measurement distance, refer to *CTIA 01.73 [8]* Section 2. For Wi-Fi 2.4 GHz and 5 GHz bands, use the guidance for the minimum measurement distance for Band 41 and 46, respectively. For Wi-F 6 GHz bands, use the guidance for the minimum measurement distance for Band 46. Allowances for shorter measurements distances are described in *CTIA 01.70 [5]* Section 2.9.4.

1.6.4 Quiet Zone Test Frequencies

Quiet zone test frequencies shall be measured for the following Wi-Fi bands.

1. ISM-band (2400-2483.5MHz): 2450 MHz \pm 1MHz (sleeve dipole and loop probe antenna)
2. 5 GHz License-Exempt (5150-5895MHz): 5500 MHz \pm 1MHz (sleeve dipole and loop probe antenna)
3. 6 GHz License-Exempt (5925-7125MHz): 6500 MHz \pm 1MHz (sleeve dipole and loop probe antenna)

Note 1: For testing at 6 GHz band, the existing quiet zone evaluation (*CTIA 01.73 [8]*) is applicable without the need for additional uncertainty. This requirement waived until 6 GHz analysis and loop probe antenna is available. Detailed Wi-Fi 6 GHz minimum measurement distance requirement is FFS.

Note 2: For additional test requirements for notebook-sized test volumes, refer to *CTIA Test Plan 01.73* section 5.4.

1.7 Form Factor Submission for Self-contained Wi-Fi/Mobile Modules

The following two cases are considered regarding the antenna subsystem options and required form factor submission for self-contained Wi-Fi/Mobile modules. Also, please refer to Appendix D for Notebook and Tablet.

The test results shall include a description and diagram or photograph of the test conditions used for the device under test.

CASE 1 with Internal Antenna: If the DUT is a self-contained Wi-Fi/Mobile Module with internal antennas, such as a PC Card, then the vendor may choose one of the following options:

1. Supply the DUT together with one of its intended host platforms, e.g., a laptop computer. In this case, the combination shall then be placed on the turntable and the results sheet shall clearly state the combination that was used in the measurements.
2. Test the Module, on its own, mounted in a holder that orientates the module in the position that represents its normal use. In this case the results sheet shall clearly state that the test did not include a host device.
3. Carry out both tests as above. This is the preferred method, but not mandatory.

CASE 2 without Internal Antenna: If the DUT is a self-contained Wi-Fi/Mobile Module without internal antennas, such as an mPCI Card, then the vendor shall supply the complete device, which includes the antennas, for testing. No individual module testing is acceptable.

1.8 List of Acronyms and Definitions

Acronym	Definition
ACK	Acknowledge
AP	Access Point
APSD	Automatic Power Save Delivery
BCC	Binary Convolutional Codes
CC	Convolutional Codes
DUT	Device Under Test
EIS	Effective Isotropic Sensitivity
GSM	Global System for Mobile communication
LAN	Local Area Network
LDPC	Low-Density Parity Check
LTE	Long Term Evolution
MIMO	Multiple Input Multiple Output
NR	New Radio
OFDMA	Orthogonal Frequency Division Multiple Access
PER	Packet Error Rate
PPDU	Physical Layer Protocol Data Unit
RAT	Radio Access Technology
RX	Receive
SA	StandAlone
TB	Trigger Base
TIS	Total Isotropic Sensitivity
TRP	Total Radiated Power
TX	Transmit
UMTS	Universal Mobile Telecommunications System
UTRA-FDD	UMTS Terrestrial Radio Access - Frequency Division Duplexing
UTRA-TDD	UMTS Terrestrial Radio Access - Time Division Duplexing

Acronym	Definition
WCDMA	Wideband Code Division Multiple Access
WLAN	Wireless Local Area Network
WMM	Wi-Fi Multimedia
WWAN	Wireless Wide Area Network

Item	Definition
Child Device	A Notebook platform utilizing an embedded WWAN Module, which is derived from a Parent Notebook platform. A Child Device is unique in that the only allowable changes relative to its Parent product are those applicable to the Notebook platform itself.
Module	Modules are finished WWAN radio devices that do not directly connect to a host via a standardized external interface such as PCMCIA, RS-232, USB, PCIExpress when using an External Interface, etc. A module may or may not include an integral antenna system or SIM/USIM interface.
Notebook	See definition in <i>CTIA 01.01.[2]</i>
Parent	A device (of any type) from which a Child device can be derived.
Simultaneous operation	A Notebook/Tablet that is capable of simultaneous Wi-Fi/Cellular operation and the user experience is that both radios are on at the same time. An example would be Hot Spot operation.
Tablet	See definition in <i>CTIA 01.01.[2]</i>
WLAN	Wireless Local Area Network (WLAN) links two or more devices using some wireless distribution method and usually providing a connection through an access point to the wider internet. Most modern WLANs are based on IEEE 802.11 standards, marketed under the Wi-Fi brand name.
WWAN	Wireless Wide Area Network refers to cellular airlink technologies as noted in Section 1.2.

Section 2 Test Conditions and Device Configuration

2.1 Cellular and Wi-Fi Modes

The test methodology requires the device be placed in a standard operational mode. This includes all sensors in the device as well as proximity sensors. If it becomes evident that DUT thermal protection and/or adaptive power control mechanisms are preventing Wi-Fi and cellular transmitters from maintaining full output power during the course of testing, the test lab shall work with the OEM to identify a suitable mitigation method. Although recognizing that the use of special test modes would enable more simplified testing and the use of formal test equipment, the test methodology proposed in this document allows the testing of any Wi-Fi mobile device in a mode that is as close as possible to its native operation. However, the methodology does require certain specific behavior of the device so that the test can be executed. DUT vendors are required to supply instructions for the lab to configure the devices as specified in this test plan.

All Radiated tests shall be made according to configurations specified in Device Testing Configurations with the device oriented as specified in *CTIA 01.71 [6]* Section 2 as applied to the Wi-Fi mode being tested.

Depending on the communication tester and device capabilities, it may be necessary to set or disable the regulatory domain (WLAN Country Code and/or Cellular MCC) setting on the WLAN tester and/or cellular base station simulator in order to test specific channel combinations. Care should be taken to present the specific regulatory domain information to the DUT in an isolated environment so that the regulatory domain information is not obtained from any external Wi-Fi access point and/or cellular network in the country where the test is being executed. The lab should seek guidance from the DUT vendor to ensure that all test channels supported by the DUT are tested.

2.2 Wi-Fi Mode

The DUT is expected to be able to associate with the WLAN tester and stay on the same RF channel for the duration of the test even when the WLAN tester signal appears to be below the sensitivity level of DUT.

Other than for 802.11ax client devices, the PING based method is the primary method for packet generation for UL Power measurement while the ACK based method is the fall-back option if the DUT does not support the PING method. The PING method is the only method to test the conducted (or radiated) power for the 802.11n mode of an 802.11 device.

For 802.11ax client devices, the HE trigger-based (HE TB) format is used for transmission in the uplink. Using HE TB helps with a more stable testing setup for 802.11ax. For 802.11ax Access Point, the PING method is used.

In the PING based method, the WLAN tester generates ICMP echo request packets with configurable transmit interval, payload size and payload type. The ICMP echo request packets are targeted at the DUT's IP stack. The DUT is expected to answer with a well-defined echo reply packet whose payload is identical to the payload of the corresponding request. For this method to be usable, the device must conform to *RFC 792 [12]* and *RFC 1122 [13]* Section 3.2.2.6.

In the ACK based method, the WLAN tester will be transmitting data frames addressed to the DUT, and the DUT is expected to be able to respond to all of these data frames with an ACK message.

Because 802.11n ACKs are sent in the basic service set (which is in the legacy mode), the 802.11n ACK is sent at 6 Mbps. However, the lowest data rate for 802.11n is 6.5 Mbps. Therefore, the PING method is the only method to test the conducted (or radiated) power for the 802.11n mode of an 802.11 device. In this method, IP traffic message will force the DUT to answer and generate defined uplink traffic using an 802.11n data rate.

The 802.11ax, HE TB is supported for OFDMA or MU-MIMO transmission in the uplink to enable simultaneous transmissions by multiple STAs. HE TB transmission is controlled entirely by the AP. A trigger frame, transmitted by the AP in advance, provides all required parameters for the participating STAs. Each participating STA transmits an HE TB PPDU simultaneously in the frame. For the purpose of 802.11ax client device testing in this test plan, an HE TB transmission is controlled entirely by the WLAN Tester. All the parameters required for the uplink transmission of the HE TB PPDUs are provided in a trigger frame to the DUT.

The following DUT settings are required to perform the test:

- Disable scan mode during testing; scanning for AP/client on other channels shall be disabled
- If applicable, disable Power Save Mode (Note that the WLAN tester will not support WMM APSD)
- If applicable, disable the Bluetooth radio during tests
- Except for the desensitization testing, the cellular transmitter in the DUT shall be inactive
- If Time Averaging is utilized in the device, the Time Averaging shall be disabled in accordance with *CTIA 01.01 [2]* Section 1.4

Radiated testing shall be performed on an unmodified device using all active antennas. Conducted tests shall be performed on each antenna port with the other antenna port(s) properly terminated. If necessary, an equivalent device may be modified to provide conducted access to each antenna port.

With the exception of 802.11b that is using 22 MHz channel bandwidth, all other Wi-Fi RATs, including 802.11n and 802.11ax, 20 MHz channels are used. 802.11n and 802.11ax should be configured for a longest guard interval option.

Section 3 Conducted Measurements

3.1 Wi-Fi Conducted RF Power Output and Receiver Sensitivity Tests

3.1.1 Test Purpose

The purpose of this test is to measure the output power level and receiver sensitivity of the Wi-Fi transceiver in the device in the conducted mode.

3.1.2 Test Setup

The basic test setup is shown in [Figure 3.1.2-1](#).

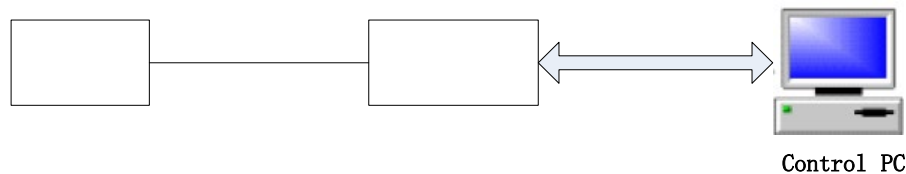

Figure 3.1.2-1 Block Diagram for Wi-Fi Conducted Measurement

[Figure 3.1.2-1](#) is intentionally generalized to maximize test equipment design flexibility. A WLAN tester may include receiver and access point capability sub modules as well as internally implemented attenuators to control transmit and receive power to and from DUT.

The DUT shall be provided to the Test Laboratory with the facility to connect directly to the RF test equipment. This may be via an existing antenna connector, or it may be a carefully modified unit to allow such a connection. In the latter case, it is the responsibility of the supplier of the DUT to ensure that the connection is present and suitable.

It is recommended that the conducted measurements be performed inside a shielded environment.

A reference measurement shall be made in order to account for the attenuation of the cable used for connecting the DUT and WLAN tester.

For more information about possible test setup configurations see the *CTIA 01.20* [3] Section 6 and for positioning guideline, see *CTIA 01.71* [6] Section 2.

3.1.3 Test Point Parameters

The measurements shall be performed on the lowest, middle and highest channels [9] supported by the device, in each of the 2.4 GHz, 5 GHz and 6 GHz bands as specified in [Table 3.1.3-1](#), all data rates specified in [Table 3.1.3-2](#) and [Table 3.1.3-3](#).

US U-NII-4 band includes two new additional 20 MHz channels 173 and 177. It also includes a part of Channel 169 that straddles between U-NII-4 and U-NII-3 that is added to U-NII-4. Only middle channel is required for US-NII-4 conducted measurements.

Applicable to all transmit and receive conducted tests of Section 3.1, for legacy RATs (i.e., 802.11a/b/g/n/ac) testing, coding shall be CC or BCC, for 802.11ax testing, coding shall be LDPC; use BCC if LDPC is not supported (e.g., in 2.4 GHz products or 20MHz-only products).

Table 3.1.3-1 Measurement Frequencies for Conducted Tests

Sub Band [14][15]	Frequency Range	Channel Range	Lowest, Middle, Highest Channel Numbers
ISM-band	2400-2483.5 MHz	1 to 13	1, 6, 11 or 13
US U-NII-1, ETSI Sub-band 1, Ofcom, ISED	5150-5250 MHz	36 to 48	36, 44, 48
US U-NII-2A, ETSI Sub-band 1, Ofcom, ISED	5250-5350 MHz	52 to 64	52, 60, 64
US U-NII-2C, ETSI Sub-band 2, Ofcom, ISED	5470-5725 MHz	100 to 140	100, 120, 140
US U-NII-3, Ofcom, ISED	5725-5850 MHz	149 to 165	149, 157, 165
US U-NII-4, ISED	5850-5895 MHz	169- to 177	173
US U-NII-5, ISED ETSI Ofcom	5945-6425 MHz	1 to 93	1, 49, 93
US U-NII-6, ISED	6425-6525 MHz	97 to 113	97, 105, 113
US U-NII-7, ISED	6525-6875 MHz	117 to 181	117, 149, 181
US U-NII-8, ISED	6875-7125 MHz	185 to 233	189, 213, 233

Table 3.1.3-2 TX Test Data Rates for Conducted Testing

Band	Mode	TX Data Rate (Mbps)
2.4 GHz	IEEE 802.11b	11
	IEEE 802.11g	6
	IEEE 802.11n	6.5
	IEEE 802.11ax	7.3
5 GHz	IEEE 802.11a	6
	IEEE 802.11n	6.5

Band	Mode	TX Data Rate (Mbps)
	IEEE 802.11ax	7.3
6 GHz	IEEE 802.11ax	7.3

Table 3.1.3-3 RX Test Data Rates for Conducted Testing

Band	Mode	RX Data Rate (Mbps)
2.4 GHz	IEEE 802.11b	11
	IEEE 802.11g	54
	IEEE 802.11n	65
	IEEE 802.11ax	73.1
5 GHz	IEEE 802.11a	54
	IEEE 802.11n	65
	IEEE 802.11ax	73.1
6 GHz	IEEE 802.11ax	73.1

3.1.4 Test Procedure for Output Power Level

This test procedure defines the basic method for measuring the transmit power of the DUT. A WLAN tester is used to establish the connection and generate traffic to and from the DUT. A calibrated WLAN tester or other applicable power measurement device (e.g., signal analyzer) is used to provide traceable power measurements.

With the PING based packet generation method, the WLAN tester will generate ICMP echo request packets with configurable transmit interval, payload size and payload type. The ICMP echo request packets are targeted at the DUT's IP stack. The DUT is expected to answer with a well-defined echo reply packet whose payload is identical to the payload of the corresponding request.

If the ACK based packet generation method is used, the power is measured across multiple ACK control frames from the DUT rather than full data packets. The ACK control frames are sent in response to unicast data packets generated by the WLAN tester. The measurement is taken across multiple packets and a mean value calculated. In the HE TB method for 802.11ax testing, the WLAN Tester is configured in 2.4, 5 or 6 GHz band depending on the test. The DUT is configured to join WLAN Tester BSS and associate to it.

For client devices, the tester is typically configured as an AP, although the tester may alternatively be configured as a non-AP STA (networking station) operating in ad-hoc mode to perform the measurement. The tester shall be configured to the channel (frequency) and data rate to be tested as specified in Section 3.1.3. Additional tester settings may also be needed to ensure that the DUT responds at the target data rate.

For access points and devices acting as mobile access points, the tester is configured as a client. In this case, the DUT shall typically be configured for the channel to be tested as specified in Section 3.1.3. The tester shall be configured for the data rate to be tested as specified in Table 3.1.3-2.

Additional tester settings may also be needed to ensure that the DUT responds at the target data rate.

The DUT shall be configured to transmit at maximum power. Note that in the case of 6 GHz band, Wi-Fi devices may operate in three modes 1) Low Power Indoor, 2) Very Low Power and 3) Standard Power. Maximum transmit power for different modes of operation may be different. The maximum transmit power is configured based on vendor declaration for device capability and mode of operation.

To generate the traffic for power measurement using the PING based method, the WLAN tester will generate ICMP echo request packets with configurable transmit interval and payload size and payload type as specified in [Table 3.1.4-1](#). The reported result is determined from the power measured over the entire payload part of the packet, ignoring the preamble and avoiding the leading and falling edge transitions in the burst. A minimum of 85% of the payload shall be covered by the measurement.

To generate the traffic for power measurement using the ACK based method, the tester is configured to send UDP packets as specified in [Table 3.1.4-1](#). [Table 3.1.4-1](#) specifies the size and payload of the packets to be transmitted and the target interval between packets. The transmitted power of the DUT is measured using the WLAN tester or other calibrated receiver capable of measuring the average power of the DATA portion of each ACK message. The reported result is determined from the power measured per ACK averaged over the number of ACKs specified in [Table 3.1.4-1](#).

To generate the traffic for 802.11ax measurement using the HE TB, the WLAN tester is configured to transmit Trigger frames to solicit TB PPDU from DUT using the following specified fields:

1. Trigger Common Info field:
 - a. UL BW = 0 (20 MHz)
 - b. GI And LTF Type = 2 (4x HE-LTF + 3.2 μs GI)
 - c. UL Target RSSI = MAX

2. User Info fields
 - a. RU Allocation = 242-tone RU
 - b. Coding = LDPC (use BCC if LDPC is not supported, e.g. in 2.4 GHz products or 20MHz-only products)
 - c. MCS = MCS0 or MCS7 according to the test case
 - d. NSS = 0 (1SS)

and parameters as specified in [Table 3.1.4-1](#). Create a table of channel, data rate, and average power for each measurement. See [Appendix A](#) for recommended data reporting formats.

Table 3.1.4-1 Parameter Settings for Output Power Level Test

Parameter	Value
Number of measurements to be averaged	PING Based: 10 ACK Based: 100 HE TB: 100
Interval between packets (ms) ¹	PING and ACK Based: 10 HE TB: 20
Tester payload size	PING Based: 1000 ² (bytes) ACK Based: 60 (bytes) HE Trigger Frame: N/A

Parameter	Value
Tester packet payload	PING Based: Pseudo random ACK Based: Pseudo random HE Trigger Frame: N/A
<p>Note 1: For PING and ACK based methods, the Interval between packets is defined as the interval between the end of a transmitted unicast packet and the beginning of the next transmitted unicast packet. For triggered method, the interval is between triggers. If the device is capable of responding reliably to packets faster than the specified interval, this time interval may be decreased. If the device is not capable of responding reliably to packets at the specified interval, this time interval may be increased as required. Indicate the used interval size in the test report.</p> <p>Note 2: If a device does not support the required packet size, use the maximum supported and indicate the used packet size in the test report.</p>	

3.1.5 Test Procedure for Receiver Sensitivity

This test procedure measures the Wi-Fi receiver sensitivity of the DUT using the WLAN tester to determine the packet error rate (PER) by counting the number of ACK control frames received from the DUT in response to repeated unicast data packets transmitted by the WLAN tester. No other traffic generation shall be enabled during this test. The PER is generally defined as the ratio of packets lost divided by the number of packets transmitted to the DUT. For the purposes of this test plan, the PER is defined at the WLAN tester as the ratio of (Packets Sent – ACKs Received) / Packets Sent, or (1 – ACKs Received / Packets Sent). Receiver Sensitivity measurements shall be performed using the calibrated WLAN tester to determine the DUT's receiver sensitivity by reporting the minimum forward-link power resulting in a PER of 10% or less with 95% confidence. The sensitivity is reported as the last passing power level measured within 1 dB of the target sensitivity level. The system shall be configured as specified in Section 3.1.4 with the exception of the changes specified in Table 3.1.5-1.

Table 3.1.5-1 Parameter Settings for Receiver Sensitivity Test

Parameter		Value
Interval between packets (ms) ¹		1
Packet size (bytes)	IEEE 802.11a/b/g/n/ax	1000 ²
Min number of packets		1000
<p>Note 1: If the device is not capable of responding reliably to packets at the 1 ms interval, this time interval may be increased as required; indicate the used interval size in the test report.</p> <p>Note 2: If a device does not support the required packet size, use the maximum supported and indicate the used packet size in the test report.</p>		

3.1.6 Results

Results shall be reported in dBm.

There are no Pass/Fail criteria. Refer to Appendix A for sample report templates.

Section 4 Radiated Measurements

4.1 Wi-Fi Total Radiated Measurements (TRP/TIS)

4.1.1 Test Purpose

The purpose of this test is to measure the Total Radiated Power and Total Isotropic Sensitivity of the Wi-Fi transceiver in the device.

4.1.2 Test Setup

Typical system schematics for both TRP and TIS measurements are shown in the following figures. The configurations shown are only representative examples of test systems configuration.

Figure 4.1.2-1 shows a configuration where both uplink and downlink communications are transmitted through the measurement antenna. This configuration does not illustrate independent amplification of both signal paths.

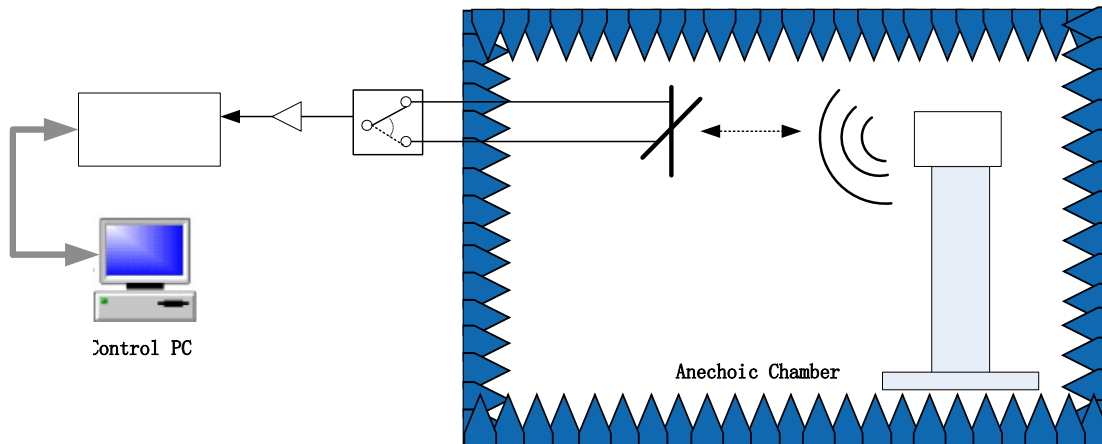

Figure 4.1.2-1 Simplified Block Diagram Showing a Common Configuration for TRP/TIS Measurement

Figure 4.1.2-2 shows a simplified block diagram showing a configuration for TRP measurement. The uplink communication is transmitted through the measurement antenna and the downlink is transmitted through the link antenna. This configuration supports amplification of both signal paths if necessary.

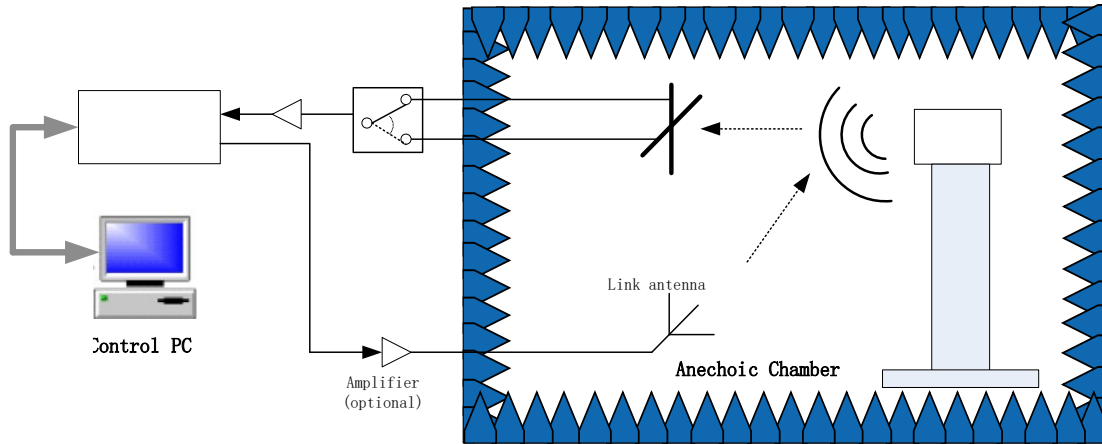

Figure 4.1.2-2 Simplified Block Diagram Showing a Configuration for TRP Measurement

Figure 4.1.2-3 shows a simplified block diagram showing a configuration for TIS measurement. The downlink communication is transmitted through the measurement antenna and the uplink is transmitted through the link antenna. This configuration supports amplification of both signal paths if necessary.

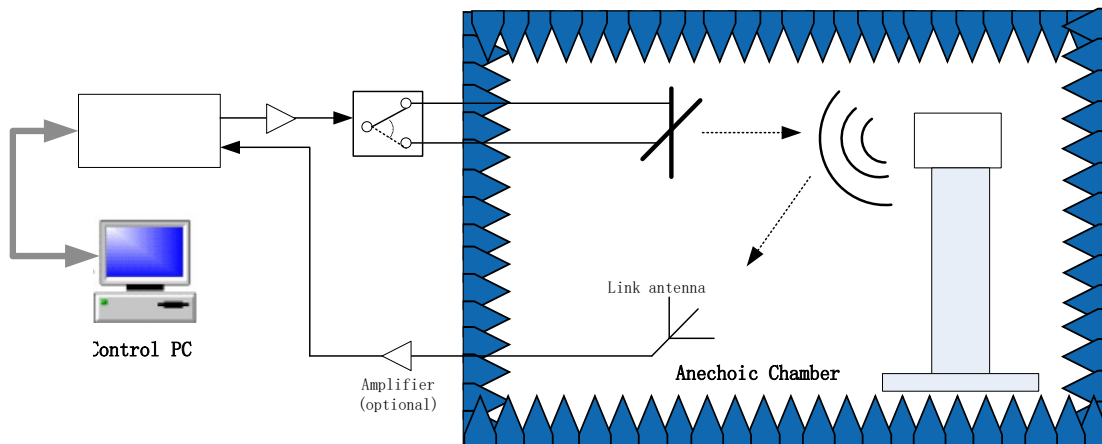

Figure 4.1.2-3 Simplified Block Diagram Showing a Configuration for TIS Measurement

For more information about possible test setup configurations and details, refer to *CTIA 01.20* [3] Section 6 for setup illustrations.

4.1.3 Test Point Parameters

For 2.4 GHz IEEE 802.11b/g/n/ax devices, the TRP/TIS measurement is made on Channel 6.

For 5 GHz IEEE 802.11a/n/ax devices and 6 GHz 11ax devices, the TRP/TIS measurement is made on the channels specified in [Table 4.1.3-1](#) for commonly supported sub-band by IEEE 802.11a, n and ax.

Table 4.1.3-1 TIS/TRP Measurement Channels for IEEE 802.11a, n and ax Supported Frequency Ranges

Frequency Range	Channel Range	TIS/TRP Channel Number
5150-5250 MHz	36 to 48	44
5250-5350 MHz	52 to 64	60
5470-5725 MHz	100 to 140	120
5725-5850 MHz	149 to 165	157
		165
5850-5895 MHz	169 to 177	173
5945-6425 MHz	1 to 93	49
6425-6525 MHz	97 to 113	105
6525-6875 MHz	117 to 181	149
6875-7125 MHz	185 to 233	213

Applicable to all transmit and receive tests of Section 4.1, for legacy RATs (i.e., 802.11a/b/g/n/ac) testing, coding shall be CC or BCC, for 802.11ax testing, coding shall be LDPC; use BCC if LDPC is not supported (e.g., in 2.4 GHz products or 20MHz-only products).

For each of the channels specified in Section 4, the transmit power output shall be measured at the data rates given in Table 4.1.3-2.

For devices which have more than one protocol in the same frequency band, such as 802.11b/g/n/ax or 802.11a/n/ax, an alternate test procedure to determine the offset in TRP between different protocols on equivalent channels can be used by referring to the Alternate Test Procedures specified in CTIA 01.20 [3] Section 3.2 Single Point Offset Test or Section 3.3 Multi-point Offset Test.

For each of the channels specified in [Table 4.1.3-2](#), the receive sensitivity shall be measured at the following data rates:

Table 4.1.3-2 Receiver Sensitivity Test Data Rates

Band	Protocol (Mode)	Test Data Rate (Mbps)
2.4 GHz	IEEE 802.11b	11
	IEEE 802.11g	54
	IEEE 802.11n	65
	IEEE 802.11ax	73.1
5 GHz	IEEE 802.11a	54
	IEEE 802.11n	65
	IEEE 802.11ax	73.1
6 GHz	IEEE 802.11ax	73.1

For devices which have more than one protocol in the same frequency band, such as 802.11b/g/n/ax in 2.4 GHz or 802.11a/n/ax in 5 GHz, an alternate test procedure to determine the offset in TIS between different protocols on equivalent channels can be used by referring to the Alternate Test Procedures specified in *CTIA 01.20* [3] Section 4.4 Single Point Offset Test or Section 4.5 Multi-point Offset Test.

4.1.4 Test Procedure for Total Radiated Power Measurement

This test procedure is primarily based on the TRP measurement procedure specified in the *CTIA Certification Test Plan for Wireless Device Over-the-Air Performance* [1]. For more details, please refer to *CTIA 01.20* [3] Section 3 for TRP test procedure.

In order to obtain accurate results of radiated performance of Wi-Fi, it is necessary to perform a range reference measurement to account for the various factors affecting the measurement of these quantities. These factors include components like range length, path loss, gain of the receive antenna, cable losses, and so forth. Please refer to *CTIA 01.73* [8] for more details.

A calibrated WLAN tester capable of maintaining the connection over the air is required. The WLAN tester or other applicable power measurement device (e.g. signal analyzer) is used to provide traceable power measurements. For TRP measurements, use the same parameter settings as specified in Section 3.1.4.

For client devices, the tester is typically configured as an AP, although ad-hoc mode may also be used to communicate with the DUT. The tester shall be configured to the channel (frequency) to be tested as specified in Section 4.1.3. The tester shall be configured for the data rate to be tested as specified in Section 4.1.6. Additional tester settings may also be needed to ensure that the DUT responds at the target data rate.

For access points and devices acting as mobile access points, the tester is configured as a client. In this case, the DUT shall typically be configured for the channel to be tested as specified in Section 4.1.3. The tester shall be configured for the data rate to be tested as specified in Section 4.1.6. Additional tester or DUT settings may also be needed to ensure that the DUT responds at the target data rate.

Capture measurement results. See [Appendix A](#) for recommended data reporting format.

Note: The test lab may choose to use Alternative Test Procedures as specified in *CTIA 01.20* [3] Section 5.4.

For devices supporting multiple Wi-Fi TX antennas, guidelines specified in the *CTIA 01.01* [2] Section 2.1.5.1 shall be used.

4.1.5 Test Procedure for Total Isotropic Sensitivity Measurement

The test procedure is primarily based on the TIS measurement procedure specified in the *CTIA Certification OTA Test Plan* [1]. The downlink power step size shall be no more than 1 dB when the RF power level is near the target sensitivity level. For more details, please refer to the procedure specified in *CTIA 01.20* [3] Section 4 for TIS measurement.

In order to obtain accurate results of radiated performance of Wi-Fi, it is necessary to perform a reference measurement to account for the various factors affecting the measurement of these quantities. These factors include components like range length, path loss, gain of the receive antenna, cable losses, and so forth. Please refer to *CTIA 01.73* [8] for more details.

A calibrated WLAN tester capable of maintaining the connection over the air is required. For TIS measurement, configure the WLAN tester as specified in Section 3.1.5 with the exception of parameters specified in Table 4.1.5-3.

Table 4.1.5-3 Parameter Settings for Receiver Sensitivity Test

Parameter	Value
Min number of packets	100

Note: The test lab may choose to use the Alternative Test Procedures as specified in *CTIA 01.20* [3] Section 4, with the exception of Section 4.7, Alternate TIS Test Procedure based on Receive Signal Strength (RSS). The minimum number of packets used during both 'Test Configuration A' and 'Test Configuration B' measurement shall be 1000 packets as outlined in Table 3.1.4-1 as opposed to the value in Table 4.1.5-3.

For devices supporting Antenna Switched RX Diversity for Wi-Fi, guidelines specified in the *CTIA 01.01* [2] 2.1.5.2 shall be used.

4.1.6 Results

Results shall be reported in dBm.

There are no Pass/Fail criteria. Refer to Appendix A for sample report templates.

4.2 Wi-Fi Desensitization Measurements with Cellular Transmitter ON

4.2.1 Test Purpose

The following measurements measure the desensitization of the Wi-Fi radio when the Cellular radio is operating.

4.2.2 Test Setup

Typical system diagrams for Wi-Fi desensitization measurements are shown in Figure 4.2.2-1 and Figure 4.2.2-2. The configurations shown are only representative examples of common systems and do not represent an exhaustive list of possible configurations.

Figure 4.2.2-1 is a simplified block diagram showing a common configuration for Wi-Fi desensitization measurements.

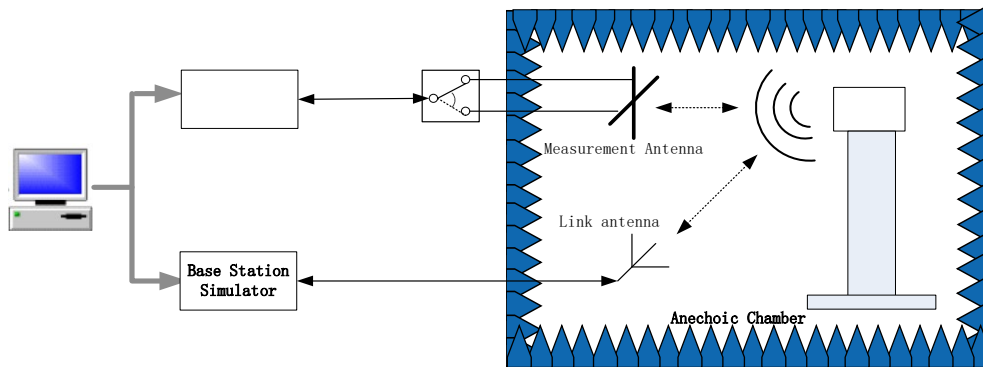

Figure 4.2.2-1 Simplified Block Diagram Showing a Common Configuration for Wi-Fi Desensitization Measurements

Figure 4.2.2-2 shows a simplified block diagram showing another common configuration for Wi-Fi desensitization measurements.

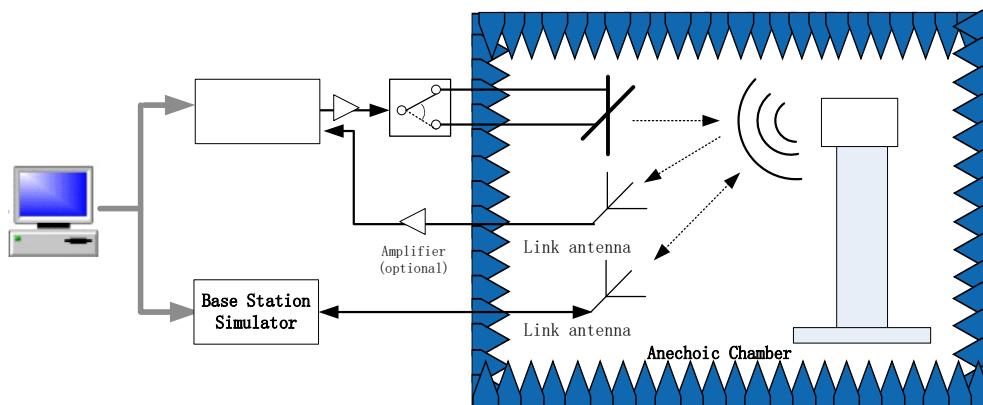

Figure 4.2.2-2 Simplified Block Diagram Showing Another Common Configuration for Wi-Fi Desensitization Measurements

For more information about possible test setup configurations see *CTIA 01.20* [3] Section 6 and for positioning guideline, see *CTIA 01.71* [6] Section 2.

4.2.3 Test Point Parameters

Desensitization measurements shall be made at the same data rates used for the TIS measurements of Section 4.1.3.

Applicable to all tests of Section 4.2, for legacy Wi-Fi RATs (i.e., 802.11a/b/g/n/ac) testing, coding shall be CC or BCC, for 802.11ax testing, coding shall be LDPC; use BCC if LDPC is not supported (e.g., in 2.4 GHz products or 20MHz-only products).

4.2.4 Test Procedures for Wi-Fi Radio Desensitization

The Wi-Fi desensitization tests consist of two groups of test scenarios related to the desensitization by closest cellular uplink frequency and desensitization by cellular uplink harmonics. Section 4.2.5 covers the test scenario and details for the closest cellular uplink frequency case while Section 4.2.6 covers the details related to the cellular uplink harmonics.

All cellular TX parameter settings shall be set according to CTIA 01.50 [4].

For the Wi-Fi desensitization tests, configure the test as specified in Section 4.1.5 for the TIS (cellular downlink is disabled on the communication tester and DUT cellular is disabled using airplane mode) testing with the exception of the setup corresponding to the desensitizing cellular signal that is specified here.

The Wi-Fi desensitization test consists of four basic steps as follows:

1. The DUT and chamber positioner(s) are moved to the location & polarization resulting in the pre-determined best-radiated free-space sensitivity (EIS) measured for the closest, in frequency, channel for which the TIS has been determined, as covered in Section 4.1.5.
2. For the Wi-Fi channels specified in Sections 4.2.5 or 4.2.6, perform a single EIS measurement using the number of packets specified in Table 4.2.4-1.

Table 4.2.4-1 Parameter Settings for Wi-Fi Radio Desensitization Test

Parameter	Value
Min number of packets	1000

3. Enable the cellular radio in the DUT and establish a cellular connection to turn on the cellular interferer and repeat measurement for all interfering channels specified in Sections 4.2.5 or 4.2.6.
4. Subtract the EIS measured in Step 2 from the EIS measured in Step 3 and report the results as the resulting desensitization. An example result table is given in Appendix A.

Depending on the details of the equipment used to conduct the tests there will be a limit to which desensitization can be measured. The search for the desensitization level shall be continued until a passing error rate is achieved or the test system limit is reached. If the DUT reaches this limit and the actual value cannot be measured, record the max EIS that the test system can produce and indicate that the limit was reached in the test report. The test equipment should be capable of measuring a desensitization level of 40 dB or more.

Appendix F lists the RATs considered in the construction of the interfering signal for these tests. If a Test Lab is presented with a device containing a RAT that is not listed, the test Lab shall contact support@wi-fi.org for clarification.

For devices supporting multiple cellular TX antennas, Wi-Fi radio desensitization shall be tested with the cellular TX antennas configured per the guidelines specified in CTIA 01.01 [2] Section 2.1.5.1.

Note: This could require multiple tests if the conditions of CTIA 01.01 [2] Section 2.1.5.2.1 apply.

4.2.5 Wi-Fi Radio Desensitization by Closest Cellular Uplink Frequency

A cellular radio transmitter in the converged device can overload the front-end of the Wi-Fi radio, or desensitize it by an out of band emission. This can happen at any cellular frequency but is usually most prevalent at cellular frequencies closest to the Wi-Fi bands.

For 2.4 GHz band, desensitization of the lowest Wi-Fi channel, Channel 1, shall be measured for all RATs supported by the device whose TX frequencies (the center of the highest channel or the center of the allocated resource blocks at the upper edge of the highest channel for LTE/NR FR1 SA as specified by the *CTIA 01.50 [4]*) fall between 1880 MHz and 2400 MHz. The measurement shall be made with the closest TX channel (and uplink RB allocation for LTE/NR FR1 SA) to Wi-Fi Channel 1.

For 2.4 GHz band, desensitization of the highest supported Wi-Fi channel (for example, Channel 11 or Channel 13) shall be measured for all RATs supported by the device whose TX frequencies (the center of the lowest channel or the center of the allocated resource blocks at the lower edge of the lowest channel for LTE/NR FR1 SA as specified by the *CTIA 01.50 [4]*) fall between 2483.5 MHz and 3003.5 MHz. The measurement shall be made with the closest TX channel (and uplink RB allocation for LTE/NR FR1 SA) to highest supported Wi-Fi channel.

For 5 GHz band, desensitization of the Wi-Fi channel 36, shall be measured for all RATs supported by the device whose TX frequencies (the center of the highest channel or the center of the allocated resource blocks at the upper edge of the highest channel for NR FR1 as specified by *CTIA 01.50 [4]*) fall between 4630 MHz and 5150 MHz. The measurement shall be made with the closest TX channel (and uplink RB allocation for LTE/NR FR1) to Wi-Fi Channel 36.

Choose the combinations with minimum frequency offset in [Table 4.2.5-1](#) depending on what Wi-Fi channels and cellular RATs the DUT supports.

If the device supports more than one band with the same RAT, then only the closest frequency (which is either the center of the channel or center of the resource blocks for LTE/NR FR1 as specified by the *CTIA 01.50 [4]*) to the 2400 MHz & 5500MHz Wi-Fi band shall be tested.

All modes 802.11 b, g, n, ax for 2.4 GHz, 802.11a, n, ax for 5 GHz and 802.11ax for 6 GHz (if supported by the Wi-Fi radio) shall be tested.

Table 4.2.5-1 Closest Channel Combinations

Wi-Fi Radio Desensitization by Closest Cellular Uplink Frequency												
Wi-Fi Channel Number	Test ID	Wi-Fi Channel Frequency (MHz)	Cellular RAT	Cellular Channel Bandwidth (MHz)	Cellular Channel Number	Center of Uplink RB Allocation (MHz)	Call Setup Reference	SCS (kHz)	Total RBs	UL RB #	UL RB Start	Frequency Gap (MHz)
1	WDC1.1	2412	GSM1900	0.18	810	1909.80	CTIA 01.50 [4]	N/A	N/A	N/A	N/A	502.20
	WDC1.2		WCDMA Band I	5	9888	1977.60	CTIA 01.50 [4]	N/A	N/A	N/A	N/A	434.40
	WDC1.3		WCDMA Band II	5	9538	1907.60	CTIA 01.50 [4]	N/A	N/A	N/A	N/A	504.40
	WDC1.4		LTE Band 1	10	18550	1983.42	CTIA 01.50 [4]	15	50	12	38	433.58
	WDC1.5		LTE Band 2	10	19150	1908.42	CTIA 01.50 [4]	15	50	12	38	503.58
	WDC1.6		LTE Band 25	5	26665	1914.03	CTIA 01.50 [4]	15	25	8	17	497.97
	WDC1.7		LTE Band 30	10	27710	2313.42	CTIA 01.50 [4]	15	50	12	38	98.58
	WDC1.8		LTE Band 39	20	38550	1917.38	CTIA 01.50 [4]	15	100	18	82	494.62
	WDC1.9		LTE Band 40	20	39550	2397.38	CTIA 01.50 [4]	15	100	18	82	14.62
	WDC1.10		NR FR1 n2	10	381000	1907.52	CTIA 01.50 [4]	15	52	12	34	504.48
	WDC1.11		NR FR1 n25	10	382000	1912.52	CTIA 01.50 [4]	15	52	12	34	499.48
11	WDC11.1	2462	LTE Band 7	20	20850	2502.62	CTIA 01.50 [4]	15	100	18	0	40.62
	WDC11.2		LTE Band 38	20	37850	2572.62	CTIA 01.50 [4]	15	100	18	0	110.62
	WDC11.3		LTE Band 41	20	39750	2498.62	CTIA 01.50 [4]	15	100	18	0	36.62
	WDC11.4		NR FR1 n41	20	501204	2499.9	CTIA 01.50 [4]	30	51	9	4	37.9

Wi-Fi Radio Desensitization by Closest Cellular Uplink Frequency												
Wi-Fi Channel Number	Test ID	Wi-Fi Channel Frequency (MHz)	Cellular RAT	Cellular Channel Bandwidth (MHz)	Cellular Channel Number	Center of Uplink RB Allocation (MHz)	Call Setup Reference	SCS (kHz)	Total RBs	UL RB #	UL RB Start	Frequency Gap (MHz)
13	WDC13.1	2472	LTE Band 7	20	20850	2502.62	CTIA 01.50 [4]	15	100	18	0	30.62
	WDC13.2		LTE Band 38	20	37850	2572.62	CTIA 01.50 [4]	15	100	18	0	100.62
	WDC13.3		LTE Band 41	20	39750	2498.62	CTIA 01.50 [4]	15	100	18	0	26.62
	WDC13.4		NR FR1 n41	20	501204	2499.9	CTIA 01.50 [4]	30	51	9	4	27.9

Example – Device 1

- 4 band GSM (1900, 1800, 900, 850),
- 5 band WCDMA (Bands I, II, IV, V, VIII),
- 5 band LTE (2, 4, 5, 13, 17)
- 3 band NR FR1 (n2, n5, n66)
- 802.11 a, b, g, n (Channels 1-11 supported @ 2400 MHz).

Bands and RATs within 520 MHz of Wi-Fi for this device are:

- WCDMA Band I (high channel - 9888, TX uplink = 1977.60 MHz) and
- WCDMA Band II (high channel – 9538, TX uplink = 1907.60 MHz)
- LTE Band 2 (high channel - 19150, 1908.42 MHz @ center of uplink RB allocation)
- GSM 1900 (high channel – 810, 1909.80 MHz)
- NR FR1 n2 (high channel – 381000, 1907.25 MHz @ center of uplink RB allocation)

Set Wi-Fi to lowest supported channel, Channel 1, 2412 MHz, for b/g/n modes.

Test the following

- Wi-Fi Channel 1 against GSM 1900 Channel 810, 1909.80 MHz
- Wi-Fi Channel 1 against WCDMA Band I Channel 9888, 1977.60 MHz
- Wi-Fi Channel 1 against LTE Band 2 Channel 19150, 1908.42 MHz, center of uplink RB allocation
- Wi-Fi Channel 1 against NR FR1 Band n2 Channel 381000, 1907.25 MHz, center of uplink RB allocation

WCDMA Band II is also within the range, but its uplink frequency (1907.6 MHz, Channel 9538) is lower in frequency than WCDMA Band I and the same RAT does not need to be tested again.

Example – Device 2

- Single band LTE TDD Band 41
- Single band NR FR1 Band n41
- 802.11 b, g, n (Channels 1-11)

Bands and RATs within 520 MHz of Wi-Fi for this device are:

- LTE TDD Band 41 (low channel, 39750, 2498.62 MHz @ center of uplink RB allocation).

NR FR1 n41 (low channel – 509202, 2546.01 MHz @ center of uplink RB allocation) Set Wi-Fi to highest supported channel, Channel 11, 2462 MHz, for b/g/n modes.

Test the following

- Wi-Fi Channel 11 against LTE TDD Band 41 Channel 39750, 2498.62 MHz @ center of uplink RB allocation
- Wi-Fi Channel 11 against NR FR1 Band n41 Channel 509202, 2546.01 MHz @ center of uplink RB allocation

4.2.6 Wi-Fi Radio Desensitization by Cellular Radio Uplink Harmonics

The cellular transmitter can produce unwanted harmonics that may interfere with certain Wi-Fi channels depending upon the combination of cellular technologies and Wi-Fi channels implemented in a converged device. [Appendix F](#) shows all known RATs and their interaction with Wi-Fi channels and many other details in a large spreadsheet. A subset of Wi-Fi channels has been selected that cover the interaction with as many RATs as possible to simplify the test selection and these are compiled into [Table 4.2.6-1](#).

The DUT desensitization shall be tested for all relevant interactions in [Table 4.2.6-1](#). The cellular radio configuration will be set according to the Call Setup Reference, in [Table 4.2.6-1](#), except for those parameters specifically defined within the table. Relevant interaction is defined by supported RAT implementation or as specified by the manufacturer.

All modes 802.11 b, g, n, ax for 2.4 GHz, 802.11a, n, ax for 5 GHz and 802.11ax for 6 GHz (if supported by the Wi-Fi radio) shall be tested. For 2.4 GHz band, only highest supported channel (for example, channel 11 or channel 13) shall be tested.

Table 4.2.6-1 Desensitization Cases

Cellular RAT & Wi-Fi Channel Pairs for Testing Harmonic Desensitization of Wi-Fi by Cellular Uplink TX														
Wi-Fi Channel	Test ID	Wi-Fi Channel Frequency (MHz)	Cellular RAT	Cellular Channel Bandwidth (MHz)	Cellular Channel Number	Center of Uplink RB Allocation (MHz)	Call Setup Reference	SCS (kHz)	Total RBs	UL RB #	UL RB Start	Harmonic Order	Harmonic Freq (MHz)	Frequency Gap (MHz)
11	WDH11.1	2462	GSM 850	0.2	128	824.2	CTIA 01.50 [4]	N/A	N/A	N/A	N/A	3	2472.6	10.6
	WDH11.2		WCDMA 850 3GPP Band V	5	4132	826.4	CTIA 01.50 [4]	N/A	N/A	N/A	N/A	3	2479.2	17.2
	WDH11.3		LTE Band 5 (not needed if LTE Band 26 is tested)	10	20450	825.58	CTIA 01.50 [4]	15	50	12	0	3	2476.74	14.74
	WDH11.4		LTE Band 26	5	26815	824.97	CTIA 01.50 [4]	15	25	8	0	3	2474.91	12.91
	WDH11.5		NR FR1 n5 (not needed if n26 is tested)	10	165800	826.48	CTIA 01.50 [4]	15	52	12	0	3	2476.2	14.2
	WDH11.6		NR FR1 n26	10	163800	819	CTIA 01.50 [4]	15	52	12	29	3	2461.86	0.14
13	WDH13.1	2472	GSM 850	0.2	128	824.2	CTIA 01.50 [4]	N/A	N/A	N/A	N/A	3	2472.6	0.6
	WDH13.2		WCDMA 850 3GPP Band V	5	4132	826.4	CTIA 01.50 [4]	N/A	N/A	N/A	N/A	3	2479.2	7.2
	WDH13.3		LTE Band 5 (not needed if LTE Band 26 is tested)	10	20450	825.58	CTIA 01.50 [4]	15	50	12	0	3	2476.74	4.74
	WDH13.4		LTE Band 26	5	26815	824.97	CTIA 01.50 [4]	15	25	8	0	3	2474.91	2.91

Cellular RAT & Wi-Fi Channel Pairs for Testing Harmonic Desensitization of Wi-Fi by Cellular Uplink TX														
Wi-Fi Channel	Test ID	Wi-Fi Channel Frequency (MHz)	Cellular RAT	Cellular Channel Bandwidth (MHz)	Cellular Channel Number	Center of Uplink RB Allocation (MHz)	Call Setup Reference	SCS (kHz)	Total RBs	UL RB #	UL RB Start	Harmonic Order	Harmonic Freq (MHz)	Frequency Gap (MHz)
	WDH13.5		NR FR1 n5 (not needed if n26 is tested)	10	165800	829	CTIA 01.50 [4]	15	52	12	0	3	2476.2	4.2
	WDH13.6		NR FR1 n26	10	165200	826	CTIA 01.50 [4]	15	52	12	9	3	2472.06	0.06
44	WDH44.1	5220	DCS 1800	0.2	661	1740.0	CTIA 01.50 [4]	N/A	N/A	N/A	N/A	3	5220	0
	WDH44.2		WCDMA 3GPP Band III	5	1075	1740.0	CTIA 01.50 [4]	N/A	N/A	N/A	N/A	3	5220	0
	WDH44.3		LTE Band 3	10	19534	1739.98	CTIA 01.50 [4]	15	50	12	0	3	5219.94	0.06
	WDH44.4		LTE Band 4 (not needed if LTE Band 66 is tested)	10	20284	1739.98	CTIA 01.50 [4]	15	50	12	0	3	5219.94	0.06
	WDH44.5		LTE Band 38	20	38150	2610	CTIA 01.50 [4]	15	100	18	41	2	5220	0
	WDH44.6		LTE Band 41	20	40864	2610.02	CTIA 01.50 [4]	15	100	18	0	2	5220.04	0.04
	WDH44.7		LTE Band 66	10	132306	1739.98	CTIA 01.50 [4]	15	50	12	0	3	5219.94	0.06
	WDH44.8		NR FR1 n41	10	520998	2610.03	CTIA 01.50 [4]	30	51	9	35	2	5220.06	0.06
	WDH44.9		NR FR1 n66	10	347400	1740.06	CTIA 01.50 [4]	15	52	12	37	3	5220.18	0.18
60	WDH60.1	5300	DCS 1800	0.2	794	1766.6	CTIA 01.50 [4]	N/A	N/A	N/A	N/A	3	5299.8	0.2
	WDH60.2		WCDMA 3GPP Band III	5	1208	1766.6	CTIA 01.50 [4]	N/A	N/A	N/A	N/A	3	5299.8	0.2

Cellular RAT & Wi-Fi Channel Pairs for Testing Harmonic Desensitization of Wi-Fi by Cellular Uplink TX														
Wi-Fi Channel	Test ID	Wi-Fi Channel Frequency (MHz)	Cellular RAT	Cellular Channel Bandwidth (MHz)	Cellular Channel Number	Center of Uplink RB Allocation (MHz)	Call Setup Reference	SCS (kHz)	Total RBs	UL RB #	UL RB Start	Harmonic Order	Harmonic Freq (MHz)	Frequency Gap (MHz)
	WDH60.3	5620	LTE Band 3	10	19800	1766.58	CTIA 01.50 [4]	15	50	12	0	3	5299.74	0.26
	WDH60.4		LTE Band 41	20	41264	2650.02	CTIA 01.50 [4]	15	100	18	0	2	5300.04	0.04
	WDH60.5		NR FR1 n41	10	529998	2649.99	CTIA 01.50 [4]	30	51	9	21	2	5299.98	0.02
	WDH60.6		NR FR1 n66	10	353400	1766.64	CTIA 01.50 [4]	15	52	12	18	3	5299.92	0.08
124	WDH124.1	5620	GSM 1900	0.2	628	1873.4	CTIA 01.50 [4]	N/A	N/A	N/A	N/A	3	5620.2	0.2
	WDH124.2		WCDMA 1900 3GPP Band II	5	9367	1873.4	CTIA 01.50 [4]	N/A	N/A	N/A	N/A	3	5620.2	0.2
	WDH124.3		LTE Band 2 (not needed if LTE Band 25 is tested)	10	18866	1873.18	CTIA 01.50 [4]	15	50	12	0	3	5619.54	0.46
	WDH124.4		LTE Band 25	5	26287	1873.17	CTIA 01.50 [4]	15	25	8	0	3	5619.51	0.49
	WDH124.5		NR FR1 n2 (not needed if NR FR1 n25 is tested)	10	375200	1873.3	CTIA 01.50 [4]	15	52	12	5	3	5619.9	0.1
	WDH124.6		NR FR1 n25	10	375200	1873.3	CTIA 01.50 [4]	15	52	12	5	3	5619.9	0.1
140	WDH140.1	5700	LTE Band 39	20	38524	1900.02	CTIA 01.50 [4]	15	100	18	0	3	5700.06	0.06
157	WDH157.1	5785	WCDMA 3GPP Band I	5	9642	1928.4	CTIA 01.50 [4]	N/A	N/A	N/A	N/A	3	5785.2	0.2

Cellular RAT & Wi-Fi Channel Pairs for Testing Harmonic Desensitization of Wi-Fi by Cellular Uplink TX														
Wi-Fi Channel	Test ID	Wi-Fi Channel Frequency (MHz)	Cellular RAT	Cellular Channel Bandwidth (MHz)	Cellular Channel Number	Center of Uplink RB Allocation (MHz)	Call Setup Reference	SCS (kHz)	Total RBs	UL RB #	UL RB Start	Harmonic Order	Harmonic Freq (MHz)	Frequency Gap (MHz)
	WDH157.2		LTE Band 1	10	18118	1928.38	CTIA 01.50 [4]	15	50	12	0	3	5785.14	0.14
173	WDH173.1	5865	WCDMA 3GPP Band I	5	9775	1955	CTIA 01.50 [4]	N/A	N/A	N/A	N/A	3	5865	0
	WDH173.2		LTE Band 1	10	18350	1951.58	CTIA 01.50 [4]	15	50	12	0	3	5854.74	10.26
141	WDH141.1	6655	NR FR1 n78	10	621668	3327.54	CTIA 01.50 [4]	30	51	9	28	2	6655.08	0.08
165	WDH165.1	6775	NR FR1 n78	10	625668	3387.54	CTIA 01.50 [4]	30	51	9	28	2	6775.08	0.08
189	WDH189.1	6895	NR FR1 n78	10	629668	3447.54	CTIA 01.50 [4]	30	51	9	28	2	6895.08	0.08
197	WDH197.1	6935	LTE Band 30	10	27710	2306.58	CTIA 01.50 [4]	15	50	12	0	3	6919.74	15.26
	WDH197.2		LTE Band 40	20	38750	2302.62	CTIA 01.50 [4]	15	100	18	0	3	6907.86	27.14
	WDH197.3		NR FR1 n30	10	462000	2311.62	CTIA 01.50 [4]	15	52	12	29	3	6934.86	0.14
	WDH197.4		NR FR1 n77 (R2)	10	630668	3467.58	CTIA 01.50 [4]	30	51	9	42	2	6935.16	0.16
	WDH197.5		NR FR1 n77 (R3)	10	630668	3467.58	CTIA 01.50 [4]	30	51	9	42	2	6935.16	0.16
209	WDH209.1	6995	LTE Band 40	20	38950	2322.62	CTIA 01.50 [4]	15	100	18	0	3	6967.86	27.14
213	WDH213.1	7015	NR FR1 SA Band n78	10	633666	3507.51	CTIA 01.50 [4]	30	51	9	28	2	7015.02	0.02
221	WDH221.1	7055	LTE Band 40	20	39150	2342.62	CTIA 01.50 [4]	15	100	18	0	3	7027.86	27.14

Cellular RAT & Wi-Fi Channel Pairs for Testing Harmonic Desensitization of Wi-Fi by Cellular Uplink TX

Wi-Fi Channel	Test ID	Wi-Fi Channel Frequency (MHz)	Cellular RAT	Cellular Channel Bandwidth (MHz)	Cellular Channel Number	Center of Uplink RB Allocation (MHz)	Call Setup Reference	SCS (kHz)	Total RBs	UL RB #	UL RB Start	Harmonic Order	Harmonic Freq (MHz)	Frequency Gap (MHz)
229	WDH229.1	7095	NR FR1 n78	10	636666	3547.47	CTIA 01.50 [4]	30	51	9	14	2	7094.94	0.06
	WDH229.2		NR FR1 n77 (R2)	10	636000	3547.56	CTIA 01.50 [4]	30	51	9	42	2	7095.12	0.12
	WDH229.3		NR FR1 n77 (R3)	10	636668	3547.5	CTIA 01.50 [4]	30	51	9	14	2	7095	0
233	WDH233.1	7115	LTE Band 48	10	55290	3557.52	CTIA 01.50 [4]	15	50	12	33	2	7115.04	0.04
	WDH233.2		NR FR1 n48	10	637334	3557.49	CTIA 01.50 [4]	30	51	9	14	2	7114.98	0.02

Example – Device 1

- 4 band GSM (1900, 1800, 900, 850),
- 5 band WCDMA (Bands I, II, V, VIII),
- 5 band LTE (2, 4, 5, 13, 17)
- 3 band NR FR1 (n2, n5, n78 Variant 1)
- 802.11 b, g, n (Channels 1-11 supported @ 2400 MHz).
- 802.11 a Channels 36 – 64
- 802.11 ax Channels 1-233

Test the following:

- Wi-Fi Channel 11 against GSM 850 Channel 128, 824.2 MHz
- Wi-Fi Channel 11 against WCDMA 850 3GPP Band V Channel 4357, 826.4 MHz
- Wi-Fi Channel 11 against LTE Band 5 Channel 20450, 825.6 MHz
- Wi-Fi Channel 11 against NR FR1 n5 Channel 165800, 829 MHz
- Wi-Fi Channel 44 against DCS 1800 GSM 1800 Channel 661, 1740.0 MHz
- Wi-Fi Channel 44 against WCDMA 3GPP Band III Channel 1300, 1740.0 MHz
- Wi-Fi Channel 44 against LTE Band 4 Channel 20250, 1740.0 MHz
- Wi-Fi Channel 60 against DCS 1800 GSM 1800 Channel 794, 1766.6 MHz
- Wi-Fi Channel 124 against NR FR1 n2 Channel 376000, 1880 MHz
- Wi-Fi Channel 141 against NR FR1 n78 Variant 1 Channel 622000, 3330 MHz
- Wi-Fi Channel 165 against NR FR1 n78 Variant 2 Channel 626000, 3390 MHz
- Wi-Fi Channel 189 against NR FR1 n78 Variant 1 Channel 623000, 3450 MHz
- Wi-Fi Channel 214 against NR FR1 n78 Variant 1 Channel 634000, 3510 MHz
- Wi-Fi Channel 229 against NR FR1 n78 Variant 2 Channel 636666, 3549.99 MHz

Example – Device 2

- Single band LTE TDD Band 41 device and 802.11 b, g, n (Channels 1-11)

No test is required.

4.2.7 Results

Results shall be reported in dB.

There are no Pass/Fail criteria. Refer to [Appendix A](#) for sample report templates.

4.3 Cellular Desensitization Measurements with Wi-Fi transmitter ON

4.3.1 Test Purpose

The purpose of this test is to conduct cellular desensitization test when the DUT's Wi-Fi transmitter is ON.

4.3.2 Test Setup

[Figure 4.3.2-1](#) shows an example test system configuration for the cellular desensitization measurement.

All desensitization tests of this section are performed in Free Space condition.

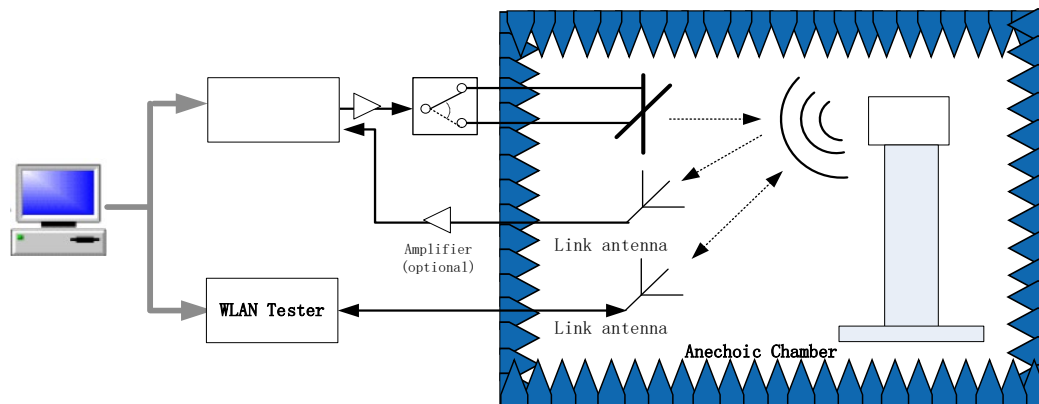

Figure 4.3.2-1 Example Test System Configuration for Cellular Desensitization Measurements

For more information about possible test setup configurations and details, refer to *CTIA 01.71* [6] Section 2 and *CTIA 01.20* [3] Section 6 for setup illustrations.

For Wi-Fi DUT transmitter stimulus, unicast UDP packets are transmitted by the WLAN tester using the MAC address of the Wi-Fi DUT. The RF port of the WLAN tester is connected to the link antenna inside the chamber.

For this test, ACK based packet generation shall be used to create the Wi-Fi interference signal. The ACK control frames are sent in response to unicast data packets generated by the WLAN tester according to the parameters specified in [Table 3.1.5-1](#). The DUT will respond with repeated ACKs which will be transmitted at maximum power.

Cellular desensitization tests shall only be performed with 802.11b, 2.4 GHz. (Note: 802.11g/n/ax devices at 2.4 GHz must support 802.11b at 2.4 GHz) and 802.11a, 5 GHz (Note: 802.11n/ac/ax devices at 5 GHz must support 802.11a at 5 GHz) and 802.11ax at 6 GHz. Data rates of [Table 3.1.3-2](#) shall be used for the Wi-Fi interference signal.

All desensitization tests of this section are performed according to the configurations specified in [Appendix B](#).

For devices supporting multiple Wi-Fi TX antennas, cellular radio desensitization shall be tested with the Wi-Fi TX antennas configured per the guidelines specified in *CTIA 01.01* [2].

Note: This could require multiple tests if the conditions of *CTIA 01.01* [2] Section 2.1.5.2.1 apply.

4.3.3 Test Point Parameters

For the purpose of Testing in Section 4.3, devices that operate in the 2.4 GHz band shall be set to operate on Channel 6 ($f_c = 2437$ MHz). Devices that operate in the 5 GHz band shall be set to operate only on the middle channel of the lowest supported sub-band in the 5 GHz range. The Middle Channel numbers corresponding to each sub-band are listed in Table 4.3.3-1. Devices that operate in the 6 GHz band shall be set to operate only on the middle channel of the lowest supported sub-band in the 6 GHz range. The Middle Channel numbers corresponding to each sub-band in 6 GHz range are listed in Table 4.3.3-2.

Table 4.3.3-1 Middle Channels for Wi-Fi Frequency Ranges in 5 GHz for TIS Cellular Desensitization

Frequency Range	Middle Channel Number	Middle Channel Center Frequency f_c
5150-5250 MHz	44	5220 MHz
5250-5350 MHz	60	5300 MHz
5470-5725 MHz	120	5600 MHz
5725-5850 MHz	157	5785 MHz
5850-5895 MHz	173	5885 MHz

Table 4.3.3-2 Middle Channels for Wi-Fi Frequency Ranges in 6 GHz for TIS Cellular Desensitization

Frequency Range	Middle Channel Number	Middle Channel Center Frequency f_c
5945-6425 MHz	49	6195 MHz
6425-6525 MHz	105	6475 MHz
6525-6875 MHz	149	6695 MHz
6875-7125 MHz	213	7015 MHz

Applicable to all tests of Section 4.3, for legacy Wi-Fi RATs (i.e., 802.11a/b/g/n/ac) testing, coding shall be CC or BCC, for 802.11ax testing, coding shall be LDPC; use BCC if LDPC is not supported (e.g., in 2.4 GHz products or 20MHz-only products).

4.3.4 Test Procedure for RATs with Free-Space TIS Limits

For GSM and UMTS RATs listed in CTIA 01.50 [4] Sections 2.1.2 and 3.1.2, perform the following steps. If Section 2.1 and Section 2.2 of CTIA 01.01 [2] allows for reduced legacy RAT testing for TIS and/or intermediate channel testing in free-space, here the same test reduction is allowed for that legacy RAT.

Initial Conditions

1. Turn on the Wi-Fi radio and let the Wi-Fi DUT associate with the WLAN tester using appropriate settings of the DUT and WLAN tester.
2. Start Wi-Fi DUT Transmitter Stimulus as specified in Section 4.3.2.

Test Procedures

1. With Wi-Fi Radio on, perform the Relative Sensitivity on Intermediate Channels test as described in Section 4.2 of CTIA 01.20 [3] at all intermediate channels according to the appropriate Receive Performance Test Procedure section of CTIA 01.50 [4].
2. Compare the resulting digital error rate or throughput rate as specified in the CTIA 01.50 [4] and determine which channels are desensitized beyond requirements specified in CTIA 01.01 [2].
3. Repeat Step 3 and Step 4 for all RATs and corresponding supporting bands.
4. Report only the intermediate channels that exceed the limit as specified in CTIA 01.01 [2].

4.3.5 Test Procedure for RATs without Free-Space TIS Limits

For RATs without reference free-space TIS limits, the test for Relative Sensitivity on Intermediate Channels cannot be performed because M1 margin values cannot be determined. In that case, the procedure listed here shall be followed until such time as limits are established. This includes all LTE/NR FR1 RATs in Section 4.1.2, 4.1.2.1 and Section 5.1.1.2 of CTIA 01.50 [4], and any bands listed in the Section 2.1.3, Section 3.1.3 and Section 4.1.3 of CTIA 01.50 [4].

If Section 2.1 and Section 3 of CTIA 01.01 [2] allows for reduced legacy RAT testing for TIS and/or intermediate channel testing in free-space, here the same test reduction is allowed for that legacy RAT.

Test Procedures

1. Determine the TIS of the DUT at the first test channel with the Wi-Fi radio transmitter switched OFF, using the data captured previously per the procedures in the CTIA 01.50 [4].
2. Use the CTIA 01.50 [4] procedures to determine the position and polarization that results in the maximum EIS value associated to Step 1.
3. Use the corresponding position and polarization of Step 2 and measure the $EIS_{(peak)}$ of the DUT at the first test channel with the Wi-Fi radio transmitter switched OFF.
4. Capture the measured EIS result as Value A.
5. Turn on the Wi-Fi radio and let the Wi-Fi DUT associate with the WLAN tester using appropriate settings of the DUT and WLAN tester.
6. Start Wi-Fi DUT Transmitter Stimulus as specified in Section 4.3.2.
7. Without re-positioning and keeping the same corresponding position and polarization of Step 2, measure the $EIS_{(peak)}$ of the DUT at the first test channel with the Wi-Fi radio transmitter switched ON. Capture the result as Value B.
8. Repeat Step 1 to Step 7 for all the applicable test channels (reference or intermediate).
9. Repeat Step 1 to Step 8 for all RATs and corresponding supporting bands.

4.3.6 VOID

4.3.7 Error Rate Measure

According to CTIA 01.50 [4], each cellular protocol (such as GSM and UMTS) specifies a different digital error rate as the DUT cellular receiver performance metric, while LTE/NR FR1 FDD and/or TDD specify the measurement of the DUT cellular receiver's throughput rate as the applicable performance metric. The error rates or throughput values shall be applied to all bands as specified in CTIA 01.50 [4].

4.3.8 Results

There are no Pass/Fail criteria.

When performing the test according to Section 4.3.4, results shall be reported by giving the channel(s) exceeding the limit. When performing the test according to Section 4.3.5, results shall be reported in dBm for the EIS values.

Refer to [Appendix A](#) for sample report templates.

Appendix A Test Reports

The following content shall be included in the test report. The tables are provided as examples for information.

Table A-1 Sample Summation

Manufacturer	
Model	
Wi-Fi Alliance CID ¹	
CTIA Request #	
Serial Number (e.g., MEID, IMEI).	
Regulatory Approval ID (e.g., FCCID)	
Hardware Version	
Software Version	

A.1 Wi-Fi Conducted Tests

Table A.1-1 Conducted RF Power Output and Receiver Sensitivity Results

Mode	Frequency Range	Channel	Data Rate (Mbps)	Tx Test ID	Output Power (dBm)	Rx Test ID	Receiver Sensitivity (dBm)
802.11b 2.4 GHz	N/A	Low	11	COP1		CRS1	
		6	11	COP2		CRS2	
		High	11	COP3		CRS3	
802.11g 2.4 GHz	N/A	Low	6	COP4		N/A	
			54	N/A	N/A	CRS4	
		6	6	COP5		N/A	
			54	N/A	N/A	CRS5	
		High	6	COP6		N/A	
			54	N/A	N/A	CRS6	

¹ Vendor supplies the Wi-Fi Alliance CID (Certification Identifier) during the CWG application process.

Mode		Frequency Range	Channel	Data Rate (Mbps)	Tx Test ID	Output Power (dBm)	Rx Test ID	Receiver Sensitivity (dBm)	
802.11n 2.4 GHz	N/A	Low		6.5	COP7		N/A		
				65	N/A	N/A	CRS7		
		6		6.5	COP8		N/A		
				65	N/A	N/A	CRS8		
		High		6.5	COP9		N/A		
				65	N/A	N/A	CRS9		
802.11ax 2.4 GHz	LDPC/BCC	N/A	Low	7.3	COP10		N/A		
				73.1	N/A	N/A	CRS10		
			6		7.3	COP11		N/A	
					73.1	N/A	N/A	CRS11	
			High		7.3	COP12		N/A	
					73.1	N/A	N/A	CRS12	
802.11a 5 GHz	5150-5250 MHz	36		6	COP13		N/A		
				54	N/A	N/A	CRS13		
		44		6	COP14		N/A		
				54	N/A	N/A	CRS14		
		48		6	COP15		N/A		
				54	N/A	N/A	CRS15		
802.11a 5 GHz	5250-5350 MHz	52		6	COP16		N/A		
				54	N/A	N/A	CRS16		
		60		6	COP17		N/A		
				54	N/A	N/A	CRS17		
		64		6	COP18		N/A		
				54	N/A	N/A	CRS18		
802.11a 5 GHz	5470-5725 MHz	100		6	COP19		N/A		
				54	N/A	N/A	CRS19		

Mode	Frequency Range	Channel	Data Rate (Mbps)	Tx Test ID	Output Power (dBm)	Rx Test ID	Receiver Sensitivity (dBm)
		120	6	COP20		N/A	
			54	N/A	N/A	CRS20	
		140	6	COP21		N/A	
			54	N/A	N/A	CRS21	

Mode	Frequency Range	Channel	Data Rate (Mbps)	Tx Test ID	Output Power (dBm)	Rx Test ID	Receiver Sensitivity (dBm)
802.11a 5 GHz	5725-5850 MHz	149	6	COP22		N/A	
			54	N/A	N/A	CRS22	
		157	6	COP23		N/A	
			54	N/A	N/A	CRS23	
		165	6	COP24		N/A	
			54	N/A	N/A	CRS24	
802.11a 5 GHz	5850-5895 MHz	173	6	COP25		N/A	
			54	N/A	N/A	CRS25	
802.11n 5 GHz	5150-5250 MHz	36	6.5	COP26		N/A	
			65	N/A	N/A	CRS26	
		44	6.5	COP27		N/A	
			65	N/A	N/A	CRS27	
		48	6.5	COP28		N/A	
			65	N/A	N/A	CRS28	
802.11n 5 GHz	5250-5350 MHz	52	6.5	COP29		N/A	
			65	N/A	N/A	CRS29	
		60	6.5	COP30		N/A	
			65	N/A	N/A	CRS30	
		64	6.5	COP31		N/A	

Mode	Frequency Range	Channel	Data Rate (Mbps)	Tx Test ID	Output Power (dBm)	Rx Test ID	Receiver Sensitivity (dBm)
			65	N/A	N/A	CRS31	
802.11n 5 GHz	5470-5725 MHz	100	6.5	COP32		N/A	
			65	N/A	N/A	CRS32	
		120	6.5	COP33		N/A	
			65	N/A	N/A	CRS33	
		140	6.5	COP34		N/A	
			65	N/A	N/A	CRS34	

Mode	Frequency Range	Channel	Data Rate (Mbps)	Tx Test ID	Output Power (dBm)	Rx Test ID	Receiver Sensitivity (dBm)
802.11n 5 GHz	5725-5850 MHz	149	6.5	COP35		N/A	
			65	N/A	N/A	CRS35	
		157	6.5	COP36		N/A	
			65	N/A	N/A	CRS36	
		165	6.5	COP37		N/A	
			65	N/A	N/A	CRS37	
802.11n 5 GHz	5850-5895 MHz	173	6.5	COP38		N/A	
			65	N/A	N/A	CRS38	
802.11ax 5 GHz	LDPC/BCC	36	7.3	COP39		N/A	
			73.1	N/A	N/A	CRS39	
		44	7.3	COP40		N/A	
			73.1	N/A	N/A	CRS40	
		48	7.3	COP41		N/A	
			73.1	N/A	N/A	CRS41	

Mode		Frequency Range	Channel	Data Rate (Mbps)	Tx Test ID	Output Power (dBm)	Rx Test ID	Receiver Sensitivity (dBm)
802.11ax 5 GHz	LDPC/BCC	5250-5350 MHz	52	7.3	COP42		N/A	
				73.1	N/A	N/A	CRS42	
			60	7.3	COP43		N/A	
				73.1	N/A	N/A	CRS43	
			64	7.3	COP44		N/A	
				73.1	N/A	N/A	CRS44	
802.11ax 5 GHz	LDPC/BCC	5470-5725 MHz	100	7.3	COP45		N/A	
				73.1	N/A	N/A	CRS45	
			120	7.3	CO46		N/A	
				73.1	N/A	N/A	CRS46	
			140	7.3	COP47		N/A	
				73.1	N/A	N/A	CRS47	
802.11ax 5 GHz	LDPC/BCC	5725-5850 MHz	149	7.3	COP48		N/A	
				73.1	N/A	N/A	CRS48	
			157	7.3	COP49		N/A	
				73.1	N/A	N/A	CRS49	
			165	7.3	COP50		N/A	
				73.1	N/A	N/A	CRS50	
802.11ax 5 GHz	LDPC/BCC	5850-5895 MHz	173	7.3	COP51		N/A	
				73.1	N/A	N/A	CRS51	
802.11ax 6 GHz	LDPC/BCC	5945-6425 MHz	1	7.3	COP52		N/A	
				73.1	N/A	N/A	CRS52	

Mode		Frequency Range	Channel	Data Rate (Mbps)	Tx Test ID	Output Power (dBm)	Rx Test ID	Receiver Sensitivity (dBm)
			49	7.3	COP53		N/A	
				73.1	N/A	N/A	CRS53	
			93	7.3	COP54		N/A	
				73.1	N/A	N/A	CRS54	
802.11ax 6 GHz	LDPC/BCC	6425-6525 MHz	97	7.3	COP55		N/A	
				73.1	N/A	N/A	CRS55	
			105	7.3	COP56		N/A	
				73.1	N/A	N/A	CRS56	
			113	7.3	COP57		N/A	
				73.1	N/A	N/A	CRS57	
802.11ax 6 GHz	LDPC/BCC	6525-6875 MHz	117	7.3	COP58		N/A	
				73.1	N/A	N/A	CRS58	
			149	7.3	COP59		N/A	
				73.1	N/A	N/A	CRS59	
			181	7.3	COP60		N/A	
				73.1	N/A	N/A	CRS60	
802.11ax 6 GHz	LDPC/BCC	6875-7125 MHz	189	7.3	COP61		N/A	
				73.1	N/A	N/A	CRS61	
			213	7.3	COP62		N/A	
				73.1	N/A	N/A	CRS62	
			233	7.3	COP63		N/A	
				73.1	N/A	N/A	CRS63	

A.2 Total Radiated Power (TRP) and Total Isotropic Sensitivity (TIS) for 2.4 GHz 802.11b, 802.11g, 802.11n and 802.11ax

Table A.2-1 TRP for 2.4 GHz 802.11b/g/n/ax

Test ID	Mode		Channel	Data Rate (Mbps)	TRP Results (dBm)
TRP1	IEEE 802.11b		6	11	
TRP2	IEEE 802.11g		6	6	
TRP3	IEEE 802.11n		6	6.5	
TRP4	IEEE 802.11ax	LDPC/BCC	6	7.3	

Table A.2-2 TIS for 2.4 GHz 802.11b/g/n/ax

Test ID	Mode		Channel	Data Rate (Mbps)	TIS Results (dBm)
TIS1	IEEE 802.11b		6	11	
TIS2	IEEE 802.11g		6	54	
TIS3	IEEE 802.11n		6	65	
TIS4	IEEE 802.11ax	LDPC/BCC	6	73.1	

A.3 Total Radiated Power (TRP) and Total Isotropic Sensitivity (TIS) for 5 GHz 802.11a, 802.11n and 802.11ax

Table A.3-1 provides the list of sub-band options and corresponding channel frequency and data rates scenarios for TRP and TIS.

Table A.3-1 TRP for 5 GHz 802.11a/n/ax

Test ID	Frequency Range	Channel Number	Mode		Data Rate (Mbps)	TRP Results (dBm)
TRP5	5150-5250 MHz	44	802.11a		6	
TRP6			802.11n		6.5	
TRP7			802.11ax	LDPC/BCC	7.3	
TRP8	5250-5350 MHz	60	802.11a		6	
TRP9			802.11n		6.5	
TRP10			802.11ax	LDPC/BCC	7.3	
TRP11	5470-5725 MHz	120	802.11a		6	
TRP12			802.11n		6.5	
TRP13			802.11ax	LDPC/BCC	7.3	
TRP14	5725-5850 MHz	157	802.11a		6	
TRP15			802.11n		6.5	
TRP16			802.11ax	LDPC/BCC	7.3	
TRP17		165	802.11a		6	
TRP18			802.11n		6.5	
TRP19			802.11ax	LDPC/BCC	7.3	
TRP20	5850-5895 MHz	173	802.11a		6	
TRP21			802.11n		6.5	
TRP22			802.11ax	LDPC/BCC	7.3	

Table A.3-2 TIS for 5 GHz 802.11a/n/ax

Test ID	Sub Band [14][15]	Frequency Range	Channel Number	Mode	Data Rate (Mbps)	TIS Results (dBm)
---------	-------------------	-----------------	----------------	------	------------------	-------------------

TIS5		5150-5250 MHz	44	802.11a		54	
TIS6				802.11n		65	
TIS7				802.11ax	LDPC/BCC	73.1	
TIS8		5250-5350 MHz	60	802.11a		54	
TIS9				802.11n		65	
TIS10				802.11ax	LDPC/BCC	73.1	
TIS11		5470-5725 MHz	120	802.11a		54	
TIS12				802.11n		65	
TIS13				802.11ax	LDPC/BCC	73.1	
TIS14		5725-5850 MHz	157	802.11a		54	
TIS15				802.11n		65	
TIS16				802.11ax	LDPC/BCC	73.1	
TIS17			165	802.11a		54	
TIS18				802.11n		65	
TIS19				802.11ax	LDPC/BCC	73.1	
TIS20		5850-5895 MHz	173	802.11a		54	
TIS21				802.11n		65	
TIS22				802.11ax	LDPC/BCC	73.1	

A.4 Total Radiated Power (TRP) and Total Isotropic Sensitivity (TIS) for 6 GHz 802.11ax

Table A.4-1 provides the list of sub-band options and corresponding channel frequency and data rates scenarios for TRP and TIS.

Table A.4-1 TRP for 6 GHz 802.11ax

Test ID	Frequency Range	Channel Number	Mode		Data Rate (Mbps)	TRP Results (dBm)
TRP23	5945-6425 MHz	49	802.11ax	LDPC/BCC	7.3	
TRP24	6425-6525 MHz	105	802.11ax	LDPC/BCC	7.3	
TRP25	6525-6875 MHz	149	802.11ax	LDPC/BCC	7.3	
TRP26	6875-7125 MHz	213	802.11ax	LDPC/BCC	7.3	

Table A.4-2 TIS for 6 GHz 802.11ax

Test ID	Frequency Range	Channel Number	Mode		Data Rate (Mbps)	TIS Results (dBm)
TIS23	5945-6425 MHz	49	802.11ax	LDPC/BCC	73.1	
TIS24	6425-6525 MHz	105	802.11ax	LDPC/BCC	73.1	
TIS25	6525-6875 MHz	149	802.11ax	LDPC/BCC	73.1	
TIS26	6875-7125 MHz	213	802.11ax	LDPC/BCC	73.1	

A.5 Wi-Fi Desensitization Measurements (with Cellular Transmitter On)

Table A.5-1 Wi-Fi Radio Desensitization by Closest Cellular Uplink Frequency

802.11		Closest Cellular Uplink Frequency		802.11	Reference Polarization	Reference Position		Desensitization (dB)	Max Provided EIS in Case of Complete Failure (dBm)
Mode	Channel	Mode	Channel	Data Rate (Mbps)		Theta	Phi		
802.11b									
802.11g									
802.11n 2.4 GHz									

802.11		Closest Cellular Uplink Frequency		802.11	Reference Polarization	Reference Position		Desensitization (dB)	Max Provided EIS in Case of Complete Failure (dBm)
Mode	Channel	Mode	Channel	Data Rate (Mbps)		Theta	Phi		
802.11ax									

Note: In case of complete failure, include the maximum EIS that the test system can provide in the last column; leave unused otherwise.

Table A.5-2 Wi-Fi Radio Desensitization by Cellular Radio Uplink Harmonics 802.11b/g/n/a/ax

802.11		Cellular Uplink Frequency		802.11	Reference Polarization	Reference Position		Desensitization (dB)	Max Provided EIS in Case of Complete Failure (dBm)
Mode	Channel	Mode	Channel	Data Rate (Mbps)		Theta	Phi		
802.11b 2.4 GHz									
802.11g 2.4 GHz									
802.11n 2.4 GHz									
802.11ax 2.4 GHz									
802.11a 5 GHz									
802.11n 5 GHz									
802.11ax 5 GHz									
802.11ax 6 GHz									

Note: In case of complete failure, include the maximum EIS that the test system can provide in the last column; leave blank otherwise.

A.6 Cellular Desensitization Measurements (with Wi-Fi Transmitter On)

Reporting Format for Intermediate Channel Sensitivity Tests according to Section 4.3.4.

Table A.6-1 Cellular Desensitization Test Results for 802.11b Operation (Wi-Fi 2.4 GHz Band) with Cellular Free-Space Limits

Cellular Technology/Band	Wi-Fi Channel	Reference Polarization	Reference Position Theta (°)	Reference Position Phi (°)	Intermediate Channels Exceeding Limit
	802.11b Ch. 6 (2437 MHz)				

Table A.6-2 Cellular Desensitization Test Results for 802.11a Operation with Cellular Free-Space Limits

Cellular Technology/Band	Wi-Fi Channel	Reference Polarization	Reference Position Theta (°)	Reference Position Phi (°)	Intermediate Channels Exceeding Limit
	802.11a middle channel of the lowest supported sub-band				

Reporting Format for EIS Tests according to Section 4.3.5.

Table A.6-3 Cellular Desensitization Test Results for 802.11b Operation (Wi-Fi 2.4 GHz Band) without Cellular Free-Space Limits

Cellular Technology Channel	Wi-Fi Channel	Reference Polarization	Reference Position Theta (°)	Reference Position Phi (°)	EIS Value A [with Wi-Fi Off] (dBm)	EIS Value B [with Wi-Fi On] (dBm)
(Low)	802.11b Ch. 6 (2437 MHz)					
(Mid)	802.11b Ch. 6 (2437 MHz)					
(High)	802.11b Ch. 6 (2437 MHz)					

Table A.6-4 Cellular Desensitization Test Results for 802.11a Operation without Cellular Free-Space Limits

Cellular Technology Channel	Wi-Fi Channel	Reference Polarization	Reference Position Theta (°)	Reference Position Phi (°)	EIS Value A [with Wi-Fi Off] (dBm)	EIS Value B [with Wi-Fi On] (dBm)
(Low)	802.11a middle channel of the lowest supported sub-band					
(Mid)	802.11a middle channel of the lowest supported sub-band					
(High)	802.11a middle channel of the lowest supported sub-band					

A.7 Machine Readable Report

The columns of CWG MRR are defined as follows:

Column A; “ATL ID”: Enter the ATL ID of the OTA lab which performed this test. This field is included to improve traceability of which OTA lab performed testing especially when OTA testing is outsourced to multiple OTA labs for a single device model.

Column B; “Wi-Fi Technology”: This field indicates the available choices with the airlink technologies currently defined in Section 1.6 using the same syntax.

Column C; “Test Metric/Test ID”: This field indicates the metrics currently defined in Sections 3.1.4 (Reporting Table A.1-1), 3.1.5 (Reporting Table A.1-1), 4.1.4 (Reporting Table A.2-1/Table A.3-1/Table A.4-1), 4.1.5 (Reporting Table A.2-2/Table A.3-2/Table A.4-2), 4.2.5 (Table 4.2.5-1), 4.2.6 (Table 4.2.6-1), and 4.3.4 using the same syntax. For each value, the test points associated with the corresponding Reporting Tables are listed in a drop-down menu to choose from.

Each Test Metric covered by a number of Test Cases (specified in the test plan) of which Test IDs are included in drop down menu to choose from. The list of Test IDs are listed in Columns S through AA for information. For each Test Case, depending on the Test Metric, a number of parameters are needed to be set according to the table below.

Data	Wi-Fi Mode (Technology)	Wi-Fi Encoding	Wi-Fi Sub-band (Frequency Range)	Wi-Fi Channel	Wi-Fi Data Rate	Cellular RAT (Band)	Cellular Channel Bandwidth	Cellular RAT Channel
Wi-Fi Conducted TX	X	X	X	X	X			
Wi-Fi Conducted RX	X	X	X	X	X			
Wi-Fi TRP	X	X	X	X	X			
Wi-Fi TIS	X	X	X	X	X			
Wi-Fi desense - Closest Cellular Uplink			X	X		X	X	X
Wi-Fi desense - Cellular Uplink Harmonics			X	X		X		X
Cellular desense due to Wi-Fi - with FS limits	X	X	X	X	X	X		
Cellular desense due to Wi-Fi - without FS limits	X	X	X	X	X	X		X
Cellular desense due to Wi-Fi - LTE	X	X	X	X	X	X		X

Column D; “Wi-Fi Radio Band”: This field indicates the bands currently defined in Section 3.1.3 using the same syntax. All possible sub-bands for Wi-Fi are listed. The values here are used for Wi-Fi Conducted/TRP/TIS tests as well as for Wi-Fi Desense and Cellular Desense tests.

Column E; “Wi-Fi Coding”: This field indicates the option for Wi-Fi coding based on Section 3.1.3.

Column F; “Device Type”: This field indicates the device type under test.

Column G; “Wi-Fi Device Class”: This field indicates the device class as related to regulatory mode that device is operating on with a maximum transmit power level. The value N/A is applicable to 2.4 GHz and 5 GHz band. All other values are applicable to the 6 GHz band.

Column H; “Number of Wi-Fi Receive Antenna(s)”: This field can be used on a limited basis to indicate Wi-Fi single receiver or multiple receivers. 1 is for single receiver. 2 is for two active receivers. 3 is for three active receivers. 4 is for four active receivers. 5, 6, 7, 8 is for 5, 6, 7, 8

active receivers, respectively. Note 4: The Machine Readable Report format only includes the baseline receive antenna switch state when switching is used with the DUT's receive antennas.

Column I; “Label of Wi-Fi Transmit Antenna Under Test”: This enumerated column will be used to associate TRP with a specific antenna when transmit diversity is supported for a particular test case. When transmit diversity is not supported for a particular test case, then “N/A” shall be entered. Each antenna shall be labelled with a letter, starting with the letter “A”.

Column J; “Cellular Power Class”: This field is used to indicate the cellular Power Classes of the device currently defined in *CTIA 01.01* [2] using the same syntax. Also, ensure that the power classes unique to NB-IoT are included. PC1-PC6 is for LTE technology, I-V is for UMTS technology, 1-5 is for GSM/GPRS technology, E1-E3 is for EGPRS technology, and 1-4 is for NR technology.

Column K; “Number of Cellular Receive Antenna(s)”: This field is used on a limited basis to indicate cellular single receiver or multiple receivers. 1 is for single receiver. 2 is for two active receivers. 3 is for three active receivers. 4 is for four active receivers. 5, 6, 7, 8 is for 5, 6, 7, 8 active receivers, respectively. The Machine Readable Report format only includes the baseline receive antenna switch state when switching is used with the DUT's receive antennas.

Column L; “Label of Cellular Transmit Antenna Under Test”: This field is used to associate TRP with a specific antenna when transmit diversity is supported for a particular test case. When transmit diversity is not supported for a particular test case, then “N/A” shall be entered. Section 1.5 of the *CTIA 01.01* [2] antenna labels as ‘Each antenna shall be labelled with a letter, starting with the letter “A”’. This same antenna label shall be used in the column when transmit diversity is supported for a particular test case. Note that these antenna labels are also used in Table RA.1-2 of the *CTIA 01.03* [18].

Column M; “Radiated Test Configuration”: This field is used to associate a test configuration (e.g. Free Space, HL, HR, etc.) per record.

Columns N; “Parametric Test Result 1”: The field in each row of this column is used to report the first measurement value according to the test metric specified in corresponding row in Column C using the same syntax.

Columns O; “Parametric Test Result 2”: The field in each row of this column is used to report the second measurement value (if applicable) according to the test metric specified in corresponding row in Column C using the same syntax. The value is N/A for those test metrics that do not require a second measurement value.

Column P; “Binary Test Result”: This binary column will be used to associate a pass/fail/info status with the test in that record.

Column Q; “Comments”: This will be the only free-form text field in the file.

Appendix B Handheld Device Testing Configurations

All handheld devices shall be tested in their primary mechanical mode, as defined by the manufacturer and noted in the test report. All hand phantom guidelines with each type of wireless device shall be followed as written in the *CTIA Certification Test Plan for Wireless Device Over-the-Air Performance* [1]. The appropriate hand phantom shall be selected according to *CTIA 01.72* [7]. For Wi-Fi testing at 6 GHz band (5925-7125MHz), the sub 6 GHz phantom specified in *CTIA 01.72* [7] is used with parameters selected at 6 GHz.

For a given device class, the test shall be performed as indicated in [Table B.1-1](#). Please note that some cases require testing with multiple configurations.

Table B.1-1 Device Testing Applicability Matrix

Device Capabilities		TIS/TRP	Wi-Fi Desensitization	Cellular Desensitization
Wi-Fi	with Simultaneous WWAN Operation	Free Space	Free Space	Free Space
	without Simultaneous WWAN Operation	Free Space	Test not Required	Test not Required
Wi-Fi Browser ²	with Simultaneous WWAN Operation	HR = Hand Right Phantom and HL = Hand Left Phantom	Free Space	Free Space
	without Simultaneous WWAN Operation	HR = Hand Right Phantom and HL = Hand Left Phantom	Test not Required	Test not Required

² As specified in Appendix O.4 of CTIA Certification OTA Test Plan [1]

Appendix C Test Channels that Require Testing, but are not Defined in the CTIA Certification OTA Test Plan

Editor Notes: Full configuration for band n78 to be included here.

Appendix D Notebook and Tablet Requirements

The purpose of this addendum is to define the requirements for Notebooks and Tablets with embedded WWAN and Wi-Fi radio modules.

Notebooks, Tablets, Convertible PCs and Hybrid PCs shall be tested in their primary mechanical mode based on the guidelines of *CTIA 01.01* [2] and noted in the test report.

To reduce the testing of the cellular de-sense measurements with Wi-Fi Transmitter ON, data only devices shall be tested according to *CTIA 01.01* [2] Section 2.1.3.

D.1 Parent/Child Relationships

During product development, the Manufacturer is expected to determine what represents the most popular configuration of components and to use that configuration for the receiver performance assessment. Once the most popular version of a Parent has been identified, all Child Devices will be assessed against only that specific version of the Parent. This will hold true even if that particular version of the Parent does not remain the most popular over time.

D.2 Parent/Child Antenna Subsystem Considerations

The antenna subsystem in a Child Device must be similar in design and performance to that of its Parent (e.g. the antenna itself may be provided by a manufacturer which differs from that used in the Parent or the transmission line type/length may differ, but the antenna subsystem must be based on the same design specification).

D.3 Test Configurations and Setup Procedures

For testing configuration and setup procedures refer to *CTIA 01.71* [6] Section 2.5.1. The setup configuration in Section L.4 will be used with the exception of the Transmitting Wi-Fi radio which will be “ON”.

Table D.3-1 Test Applicability Matrix

Device Capabilities	Wi-Fi TRP/TIS	Wi-Fi Desensitization	Cellular Desensitization
Case 1: Simultaneous WWAN and Wi-Fi operation	Free Space	Free Space	Free Space
Case 2: WWAN and Wi-Fi not operating simultaneously	Free Space	Test not Required	Test not Required

Case 1: Notebooks and Tablets that are capable of simultaneous WWAN and Wi-Fi operation

Case 2: Notebooks and Tablets that are not capable of simultaneous WWAN/Wi-Fi operation

Appendix E Wi-Fi-LTE Emulator Test Equipment Notes when Testing DUTs that Support LTE Band 40 or 41 (Informative)

This is an informative appendix. The information in this appendix is to inform test labs that care should be used with test equipment when performing tests with DUTs that support LTE Band 40 or 41. With an incorrect test setup, results may be incorrect because of test equipment desensitization. Proper RF isolation is required between the cellular and Wi-Fi emulators. The test diagrams shown in this appendix are examples and variations of the test setup may differ or may not be required for each test lab.

Proper Wi-Fi and LTE emulator test equipment setup is required for Wi-Fi or cellular desensitization measurements for DUTs that support LTE Bands 40 or 41. LTE Bands 40 and 41 are next to the 2.4 GHz Wi-Fi band with little or no guard bands (see [Figure E-1](#) and [Figure E-2](#).) There is the possibility that the Wi-Fi or LTE emulator would be unable to attach to the DUT when performing these measurements due to test equipment immunity issues. The test lab shall insure they are measuring the over the air DUT Wi-Fi or cellular desensitization and not Wi-Fi or LTE emulator test equipment immunity.

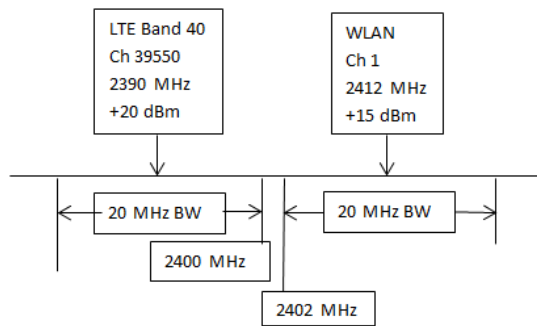

Figure E-1 LTE Band 40 and Wi-Fi 2.4 GHz Frequency Diagram

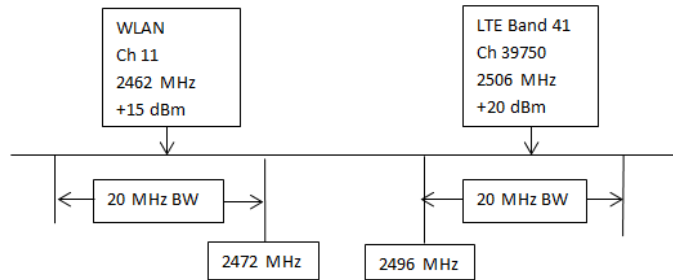

Figure E-2 LTE Band 41 and Wi-Fi 2.4 GHz Frequency Diagram

The test lab can verify Wi-Fi emulator test equipment immunity with the example test equipment diagram in [Figure E-3](#). RF cavity tuned notch and/or bandpass filters are used to ensure the DUT is not desensitized by the LTE device and for the LTE device to stay attached to the LTE emulator due to interference from the Wi-Fi. Attenuators can be used to simulate expected RF levels present at the Wi-Fi emulator while performing Wi-Fi DUT over the air desensitization measurements. Perform sensitivity measurements with the DUT only (without LTE Band 40) and note results. Then attach LTE Band 40 DUT to the LTE emulator (at maximum output power). With the LTE Band 40 DUT attached, re-measure the Wi-Fi DUT. If the Wi-Fi sensitivity measurements are the same and Wi-Fi/LTE DUTs remain

attached, the Wi-Fi emulator is immune to the adjacent channel interference. LTE base station emulator test equipment immunity can be verified by exchanging the positions of the emulators, RF filters and DUTs in the diagram.

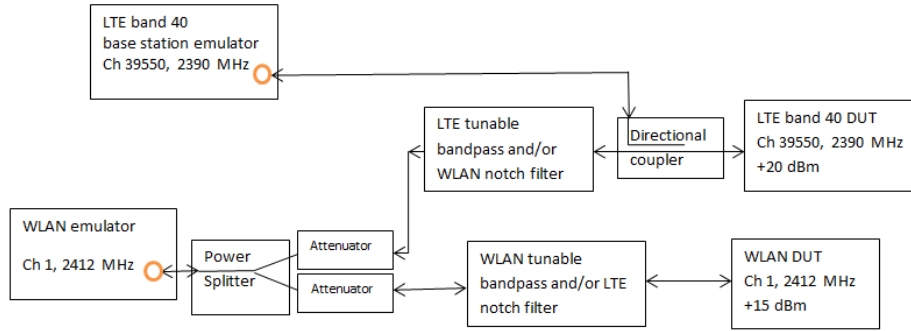

Figure E-3 Wi-Fi Emulator Test Equipment Verification Test Setup (to Test the LTE Base Station)

If the Wi-Fi or LTE emulator does show immunity problems, diagram [Figure E-4](#) shows an example on how to eliminate these problems (use RF filters as needed). If the lab is using an RF compression amplifier for the LTE input emulator, the RF filter must be installed after the output of the amplifier. If the device can stay attached to the LTE emulator, no RF filter is required. If the lab is using an RF preamplifier for the Wi-Fi emulator input, the RF filter should be connected to the input of the preamplifier. Care should be used when tuning the RF filters. If a Wi-Fi bandpass RF filter is used, be sure to add its loss into the system path loss and remove the filters when performing Wi-Fi TRP or TIS measurements.

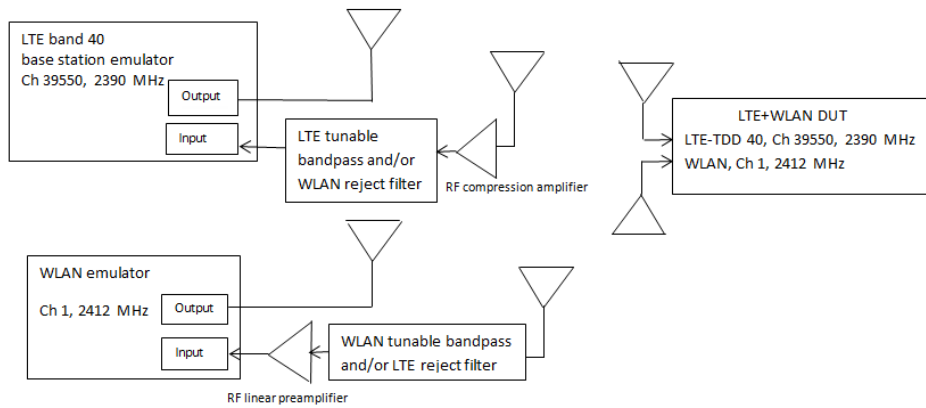

Figure E-4 Example Test System Diagram (Only for Wi-Fi Desensitization or LTE Cellular Desensitization Tests, if the DUT Supports LTE Band 40)

Appendix F Table of Wi-Fi Radio Channels Interfered by Cellular Radio Harmonics

The cellular radio configuration will be set according to the Call Setup Reference, in the table below, except for those parameters specifically defined within the table.

RAT	GSM 850		E-GSM 900		DCS 1800		GSM 1900			
Region	North America, South America, Asia		South America, EU, Asia, Australia. Africa		South America, EU, Asia, Australia. Africa		North America, South America			
Suggested alternate name										
Call setup defined in reference document	CTIA 01.50 [1], Section 2.1.1		CTIA 01.50 [1], Section 2.1.3		CTIA 01.50 [1], Section 2.1.3		CTIA 01.50 [1], Section 2.1.1			
Special setup										
Band Edges										
Uplink Freq	824.2	848.8	880.2	914.8	1710.2	1784.8	1850.2	1909.8		
Downlink Freq	869.2	893.8	925.2	959.8	1805.2	1879.8	1930.2	1989.8		
Desensitization of Wi-Fi Rx by Cellular Tx Uplink										
	Chan	Freq	Chan	Freq	Chan	Freq	Chan	Freq	Chan	Freq
802.11b/g/n/ax	1	2412								
	2	2417								
	3	2422		Bold box borders indicate Wi-Fi Rx vulnerability due to Cellular uplink Tx						
	4	2427								
	5	2432								
	6	2437								
	7	2442								
	8	2447								
	9	2452								
	10	2457								
	11	2462	128	824.2						
	12	2467								
	13	2472	128	824.2						



802.11a/n/ac/ax U-NII-1 ETSI 5GHz Sub- band 1	36	5180								
	40	5200								
	44	5220				661	1740			
	48	5240								
802.11a/n/ac/ax U-NII-2A ETSI 5GHz Sub- band 1	52	5260								
	56	5280								
	60	5300				794	1766.6			
	64	5320								
802.11a/n/ac/ax U-NII-2C ETSI 5GHz Sub-band 2	100	5500								
	112	5560								
	116	5580								
	120	5600								
	124	5620						628	1873.4	
	128	5640								
	132	5660								
	136	5680								
	140	5700								
802.11a/n/ac/ax U-NII-3 Ofcom	149	5745								
	153	5765								
	157	5785								
	161	5805								
	165	5825								
802.11a/n/ac /ax U-NII-4	169	5845								
	173	5865								
	177	5885								

802.11ax U-NI-5 ETSI 6GHz	1	5955								
	5	5975								
	9	5995								
	13	6015								
	17	6035								
	21	6055								
	25	6075								
	29	6095								
	33	6115								
	37	6135								
	41	6155								
	45	6175								
	49	6195								
	53	6215								
	57	6235								
	61	6255								
	65	6275								
	69	6295								
	73	6315								
	77	6335								
81	6355									
85	6375									
89	6395									
93	6415									
802.11ax U-NI-6 ETSI 6GHz	97	6435								
	101	6455								
	105	6475								
	109	6495								
	113	6515								

802.11ax U-NII-7	117	6535								
	121	6555								
	125	6575								
	129	6595								
	133	6615								
	137	6635								
	141	6655								
	145	6675								
	149	6695								
	153	6715								
	157	6735								
	161	6755								
	165	6775								
	169	6795								
	173	6815								
	177	6835								
181	6855									
802.11ax U-NII-8	185	6875								
	189	6895								
	193	6915								
	197	6935								
	203	6955								
	207	6975								
	211	6995								
	214	7015								
	217	7035								
	221	7055								
	225	7075								
	229	7095								
	233	7115								

RAT	WCDMA 3GPP Band I		WCDMA 1900 3GPP Band II		WCDMA 3GPP Band III		WCDMA 850 3GPP Band V		WCDMA 3GPP Band VIII		
Region	EU, Asia, Middle East, Africa, Australia		North America, South America, Asia		EU, Asia		North America, South America, Asia, Australia		EU, Asia, South America, Middle East, Australia, Africa		
Suggested alternate name											
Call setup defined in reference document	CTIA 01.50 [4], Section 3.1		CTIA 01.50 [4], Section 3.1		CTIA 01.50 [4], Section 3.1		CTIA 01.50 [4], Section 3.1		CTIA 01.50 [4], Section 3.1		
Special setup											
Band Edges											
Uplink Freq	1920	1980	1850	1910	1710	1785	824	849	880	915	
Downlink Freq	2110	2170	1930	1990	1805	1880	869	894	925	960	
802.11b/g/n/ax											
Chan	Freq	Chan	Freq	Chan	Freq	Chan	Freq	Chan	Freq	Chan	Freq
1	2412										
2	2417										
3	2422			Bold box borders indicate Wi-Fi Rx vulnerability due to Cellular uplink Tx							
4	2427										
5	2432										
6	2437										
7	2442										
8	2447										
9	2452										
10	2457										
11	2462							4357	826.4		
12	2467										
13	2472							4357	826.4		



802.11a/n/ac/ax U-NII-1	36	5180											
	40	5200											
	44	5220				1300	1740						
	48	5240											
802.11a/n/ac/ax U-NII-2A	52	5260											
	56	5280											
	60	5300				1433	1766.6						
	64	5320											
802.11a/n/ac/ax U-NII-2C ETSI 5GHz Sub-band 2	100	5500											
	112	5560											
	116	5580											
	120	5600											
	124	5620			9767	1873.4							
	128	5640											
	132	5660											
	136	5680											
	140	5700											
802.11a/n/ac/ax U-NII-3 Ofcom	149	5745											
	153	5765											
	157	5785	10592	1928.4									
	161	5805											
	165	5825											
802.11a/n/ac/ax U-NII-4	169	5845											
	173	5865	9775	1955									
	177	5885											

802.11ax U-NII-5 ETSI 6GHz	1	5955											
	5	5975											
	9	5995											
	13	6015											
	17	6035											
	21	6055											
	25	6075											
	29	6095											
	33	6115											
	37	6135											
	41	6155											
	45	6175											
	49	6195											
	53	6215											
	57	6235											
	61	6255											
	65	6275											
	69	6295											
73	6315												
77	6335												
81	6355												
85	6375												
89	6395												
93	6415												
802.11ax U-NII-6 ETSI 6GHz	97	6435											
	101	6455											
	105	6475											
	109	6495											
	113	6515											

802.11ax U-NII-7	117	6535											
	121	6555											
	125	6575											
	129	6595											
	133	6615											
	137	6635											
	141	6655											
	145	6675											
	149	6695											
	153	6715											
	157	6735											
	161	6755											
	165	6775											
	169	6795											
	173	6815											
	177	6835											
181	6855												
802.11ax U-NII-8	185	6875											
	189	6895											
	193	6915											
	197	6935											
	201	6955											
	205	6975											
	209	6995											
	213	7015											
	217	7035											
	221	7055											
	225	7075											
	229	7095											
	233	7115											

802.11a/n/ac/ax U-NII-1 ETSI 5GHz Sub-band 1	36	5180																	
	40	5200																	
	44	5220				19534	1743.4	20284	1743.4										
	48	5240																	
802.11a/n/ac/ax U-NII-2A ETSI 5GHz Sub-band 1	52	5260																	
	56	5280																	
	60	5300				19800	1770												
	64	5320																	
802.11a/n/ac/ax U-NII-2C ETSI 5GHz Sub-band 2	100	5500																	
	112	5560																	
	116	5580																	
	120	5600																	
	124	5620			1876.6	1876.6													
	128	5640																	
	132	5660																	
	140	5700																	
802.11a/n/ac/ax U-NII-3 Ofcom	149	5745																	
	153	5765																	
	157	5785	18118	1931.8															
	161	5805																	
	165	5825																	
802.11a/n/ac/ax U-NII-4	169	5845																	
	173	5865	18350	1955															
	177	5885																	

802.11ax U-NII-5 ETSI 6GHz	1	5955																	
	5	5975																	
	9	5995																	
	13	6015																	
	17	6035																	
	21	6055																	
	25	6075																	
	29	6095																	
	33	6115																	
	37	6135																	
	41	6155																	
	45	6175																	
	49	6195																	
	53	6215																	
	57	6235																	
	61	6255																	
	65	6275																	
	69	6295																	
73	6315																		
77	6335																		
81	6355																		
85	6375																		
89	6395																		
93	6415																		
802.11ax U-NII-6 ETSI 6GHz	97	6435																	
	101	6455																	
	105	6475																	
	109	6495																	
	113	6515																	

802.11ax U-NII-7	117	6535																		
	121	6555																		
	125	6575																		
	129	6595																		
	133	6615																		
	137	6635																		
	141	6655																		
	145	6675																		
	149	6695																		
	153	6715																		
	157	6735																		
	161	6755																		
	165	6775																		
	169	6795																		
	173	6815																		
177	6835																			
181	6855																			
802.11ax U-NII-8	185	6875																		
	189	6895																		
	193	6915																		
	197	6935																		
	201	6955																		
	205	6975																		
	209	6995																		
	213	7015																		
	217	7035																		
	221	7055																		
	225	7075																		
	229	7095																		
	233	7115																		

RAT	LTE Band 14		LTE Band 20		LTE Band 25		LTE Band 26		LTE Band 30		LTE Band 66		LTE Band 70		LTE Band 71		
Region	North America		EU, Middle East, Africa		North America		North America		North America		North America		North America		North America		
Suggested alternate name			E-UTRA Band 20														
Call setup defined in reference document	CTIA 01.50 [4], Section 4.1		CTIA 01.50 [4], Section 4.1		CTIA 01.50 [4], Section 4.1		CTIA 01.50 [4], Section 4.1		CTIA 01.50 [4], Section 4.1		CTIA 01.50 [4], Section 4.1		CTIA 01.50 [4], Section 4.1		CTIA 01.50 [4], Section 4.1		
Special setup	10 MHz Tx BW, 12 RBs RBstart=0		10 MHz Tx BW, 12 RBs RBstart=0		5 MHz Tx BW, 8 RBs, RBstart=0		5 MHz Tx BW, 8 RBs, RBstart=0		10 MHz Tx BW, 12 RBs RBstart=0		10 MHz Tx BW, 12 RBs RBstart=0		15 MHz Tx BW, 16 RBs RBstart=0		10 MHz Tx BW, 12 RBs RBstart=0		
Band Edges																	
Uplink Freq		788	798	832	862	1850	1915	814	849	2305	2315	1710	1780	1695	1710	663	698
Downlink Freq		758	768	791	821	1930	1995	859	994	2350	2360	2110	2100	1995	2020	617	652
Channel List																	
		Chan	Freq	Chan	Freq	Chan	Freq	Chan	Freq	Chan	Freq	Chan	Freq	Chan	Freq	Chan	Freq
802.11b/g/n/ax	1	2412															
	2	2417															
	3	2422															
	4	2427															
	5	2432															
	6	2437															
	7	2442															
	8	2447															
	9	2452															
	10	2457															
	11	2462							26815	826.5							
	12	2467															
	13	2472							26815	826.5							



802.11a/n/ac/ax U-NII-1 ETSI 5GHz Sub-band 1	36	5180																
	40	5200																
	44	5220										132306	1743.4					
	48	5240																
802.11a/n/ac/ax U-NII-2A ETSI 5GHz Sub-band 1	52	5260																
	56	5280																
	60	5300																
	64	5320																
802.11a/n/ac/ax U-NII-2C ETSI 5GHz Sub-band 2	100	5500																
	112	5560																
	116	5580																
	120	5600																
	124	5620					26287	1874.7										
	128	5640																
	132	5660																
	136	5680																
140	5700																	
802.11a/n/ac/ax U-NII-3 Ofcom	149	5745																
	153	5765																
	157	5785																
	161	5805																
	165	5825																

802.11a/n/ac /ax U-NII-4	169	5845																	
	173	5865																	
	177	5885																	
802.11ax U-NII-5 ETSI 6GHz	1	5955																	
	5	5975																	
	9	5995																	
	13	6015																	
	17	6035																	
	21	6055																	
	25	6075																	
	29	6095																	
	33	6115																	
	37	6135																	
	41	6155																	
	45	6175																	
	49	6195																	
	53	6215																	
	57	6235																	
	61	6255																	
	65	6275																	
	69	6295																	
73	6315																		
77	6335																		
81	6355																		
85	6375																		
89	6395																		
93	6415																		
802.11ax U-NII-6 ETSI 6GHz	97	6435																	
	101	6455																	
	105	6475																	
	109	6495																	
	113	6515																	

802.11ax U-NII-7	117	6535																	
	121	6555																	
	125	6575																	
	129	6595																	
	133	6615																	
	137	6635																	
	141	6655																	
	145	6675																	
	149	6695																	
	153	6715																	
	157	6735																	
	161	6755																	
	165	6775																	
	169	6795																	
	173	6815																	
	177	6835																	
181	6855																		
802.11ax U-NII-8	185	6875																	
	189	6895																	
	193	6915																	
	197	6935								27710	2310								
	201	6955																	
	205	6975																	
	209	6995																	
	213	7015																	
	217	7035																	
	221	7055																	
	225	7075																	
	229	7095																	
	233	7115																	

RAT	LTE Band 38		LTE Band 39		LTE Band 40		LTE Band 41		LTE Band 48			
Region	EU, Asia, Middle East		Asia		Asia, Australia, Middle East, Africa		North America, Asia		North America			
Suggested alternate name												
Call setup defined in reference document	CTIA 01.50 [4], Section 4.1		CTIA 01.50 [4], Section 4.1		CTIA 01.50 [4], Section 4.1		CTIA 01.50 [4], Section 4.1		CTIA 01.50 [4], Section 4.1			
Special setup	20 MHz Tx BW, 18 RBs, RBstart=0		20 MHz Tx BW, 18 RBs, RBstart=0		20 MHz Tx BW, 18 RBs, RBstart=0		20 MHz Tx BW, 18 RBs, RBstart=0		10 MHz Tx BW, 18 RBs, RBstart=0			
Band Edges												
Uplink Freq		2570	2620	1880	1920	2300	2400	2496	2690	3550	3700	
Downlink Freq		2570	2620	1880	1920	2300	2400	2496	2690	3550	3700	
Desensitization of Wi-Fi Rx by Cellular Tx Uplink												
Chan		Freq	Chan	Freq	Chan	Freq	Chan	Freq	Chan	Freq	Chan	Freq
802.11b/g/n/ax	1	2412										
	2	2417										
	3	2422			Bold box borders indicate Wi-Fi Rx vulnerability due to Cellular uplink Tx							
	4	2427										
	5	2432										
	6	2437										
	7	2442										
	8	2447										
	9	2452										
	10	2457										
	11	2462										
	12	2467										
	13	2472										



802.11a/n/ac/ax U-NII-1 ETSI 5GHz Sub-band 1	36	5180										
	40	5200										
	44	5220	38150	2610					40864	2617.4		
	48	5240										
802.11a/n/ac/ax U-NII-2A ETSI 5GHz Sub-band 1	52	5260										
	56	5280										
	60	5300							41264	2657.4		
	64	5320										
802.11a/n/ac/ax U-NII-2C ETSI 5GHz Sub-band 2	100	5500										
	112	5560										
	116	5580										
	120	5600										
	124	5620										
	128	5640										
	132	5660										
	136	5680										
	140	5700			38524	1907.4						
802.11a/n/ac/ax U-NII-3 Ofcom	149	5745										
	153	5765										
	157	5785										
	161	5805										
	165	5825										
802.11a/n/ac /ax U-NII-4	169	5845										
	173	5865										
	177	5885										

802.11ax U-NII-5 ETSI 6GHz	1	5955											
	5	5975											
	9	5995											
	13	6015											
	17	6035											
	21	6055											
	25	6075											
	29	6095											
	33	6115											
	37	6135											
	41	6155											
	45	6175											
	49	6195											
	53	6215											
	57	6235											
	61	6255											
	65	6275											
	69	6295											
	73	6315											
	77	6335											
81	6355												
85	6375												
89	6395												
93	6415												
802.11ax U-NII-6 ETSI 6GHz	97	6435											
	101	6455											
	105	6475											
	109	6495											
	113	6515											

802.11ax U-NII-7	117	6535										
	121	6555										
	125	6575										
	129	6595										
	133	6615										
	137	6635										
	141	6655										
	145	6675										
	149	6695										
	153	6715										
	157	6735										
	161	6755										
	165	6775										
	169	6795										
	173	6815										
177	6835											
181	6855											
802.11ax U-NII-8	185	6875										
	189	6895										
	193	6915										
	197	6935					38750	2310				
	201	6955										
	205	6975										
	209	6995					38950	2330				
	213	7015										
	217	7035										
	221	7055					39150	2350				
	225	7075										
	229	7095										
	233	7115									55290	3555

802.11a/n/ac/ax U-NII-1 ETSI 5GHz Sub-band 1	36	5180																
	40	5200																
	44	5220										347400	1737					
	48	5240																
802.11a/n/ac/ax U-NII-2A ETSI 5GHz Sub-band 1	52	5260																
	56	5280																
	60	5300										353400	1767					
	64	5320																
802.11a/n/ac/ax U-NII-2C ETSI 5GHz Sub-band 2	100	5500																
	112	5560																
	116	5580																
	120	5600																
	124	5620	375200	1876			376500	1879.66										
	128	5640																
	132	5660																
	136	5680																
802.11a/n/ac/ax U-NII-3 Ofcom	149	5745																
	153	5765																
	157	5785																
	161	5805																
	165	5825																
802.11a/n/ac /ax U-NII-4	169	5845																
	173	5865																
	177	5885																

802.11ax U-NII-5 ETSI 6GHz	1	5955																
	5	5975																
	9	5995																
	13	6015																
	17	6035																
	21	6055																
	25	6075																
	29	6095																
	33	6115																
	37	6135																
	41	6155																
	45	6175																
	49	6195																
	53	6215																
	57	6235																
	61	6255																
	65	6275																
	69	6295																
	73	6315																
	77	6335																
81	6355																	
85	6375																	
89	6395																	
93	6415																	
802.11ax U-NII-6 ETSI 6GHz	97	6435																
	101	6455																
	105	6475																
	109	6495																
	113	6515																

802.11ax U-NII-7	117	6535																
	121	6555																
	125	6575																
	129	6595																
	133	6615																
	137	6635																
	141	6655																
	145	6675																
	149	6695																
	153	6715																
	157	6735																
	161	6755																
	165	6775																
	169	6795																
	173	6815																
177	6835																	
181	6855																	
802.11ax U-NII-8	185	6875																
	189	6895																
	193	6915																
	197	6935								462000	2310							
	201	6955																
	205	6975																
	209	6995																
	213	7015																
	217	7035																
	221	7055																
	225	7075																
	229	7095																
	233	7115																

802.11a/n/ac/ax U-NII-1 ETSI 5GHz Sub-band 1	36	5180																
	40	5200																
	44	5220	520998	2604.99														
	48	5240																
802.11a/n/ac/ax U-NII-2A ETSI 5GHz Sub-band 1	52	5260																
	56	5280																
	60	5300	529998	2649.99														
	64	5320																
802.11a/n/ac/ax U-NII-2C ETSI 5GHz Sub-band 2	100	5500																
	112	5560																
	116	5580																
	120	5600																
	124	5620																
	128	5640																
	132	5660																
	136	5680																
	140	5700																
802.11a/n/ac/ax U-NII-3 Ofcom	149	5745																
	153	5765																
	157	5785																
	161	5805																
	165	5825																
802.11a/n/ac/ax U-NII-4	169	5845																
	173	5865																
	177	5885																

802.11ax U-NII-5 ETSI 6GHz	1	5955																		
	5	5975																		
	9	5995																		
	13	6015																		
	17	6035																		
	21	6055																		
	25	6075																		
	29	6095																		
	33	6115																		
	37	6135																		
	41	6155																		
	45	6175																		
	49	6195																		
	53	6215																		
	57	6235																		
	61	6255																		
	65	6275																		
	69	6295																		
	73	6315																		
	77	6335																		
81	6355																			
85	6375																			
89	6395																			
93	6415																			
802.11ax U-NII-6 ETSI 6GHz	97	6435																		
	101	6455																		
	105	6475																		
	109	6495																		
	113	6515																		

802.11ax U-NII-7	117	6535																		
	121	6555																		
	125	6575																		
	129	6595																		
	133	6615																		
	137	6635																		
	141	6655															621668	3325.02		
	145	6675																		
	149	6695																		
	153	6715																		
	157	6735																		
	161	6755																		
	165	6775															625668	3385.02		
	169	6795																		
	173	6815																		
177	6835																			
181	6855																			
802.11ax U-NII-8	185	6875																		
	189	6895																	629668	3445.02
	193	6915																		
	197	6935								630668	3460.02	630668	3460.02							
	201	6955																		
	205	6975																		
	209	6995																		
	213	7015																	633666	3504.99
	217	7035																		
	221	7055																		
	225	7075																		
	229	7095							636000	3540	636668	3550.02							636666	3549.99
	233	7115				637334	3560.01													



Appendix G Special Test Requirements (Informative)

The purpose of this appendix is to define special test requirements. This appendix is written in a normative context, but all or portions of the text may be considered normative or informative based on the certification body that incorporates the test plan.

There are currently no special test requirements.

Appendix H Revision History

Date	Version	Description
August 2006	1.0	Document Approved
August 2007	1.1	<p>Updated Purpose and References sections</p> <p>Clarified text and added footnote in Radiated RF Tests nomenclature section</p> <p>Clarified text in Minimum Measurement Distance section</p> <p>Clarified testing conditions for cellular inactive state</p> <p>Corrected step reference in step 14 of Receive Sensitivity Measurement. Removed repeated text.</p> <p>Removed reference to CTIA website for traffic generator software download</p> <p>Corrected step 1 and clarified language in step 9 regarding antenna connection in WLAN Access Point Testing Methodology section</p> <p>Removed requirement for OFMD transmit mask test on Mobile Stations and Access Points</p> <p>Updated WLAN Test Set Estimated Signal Level tables</p> <p>Added Sample Summation test report table</p> <p>Corrected title on Test 5.2.2. and 6.2.2 test report table</p> <p>Added text to clarify that Wi-Fi desensitization testing is done in free-space only</p> <p>Clarified that cellular desensitization testing is done in free-space only, and to perform reference measurements if not previously done</p> <p>Removed references to specific test equipment from document</p>
June 2008	1.2	<p>5 GHz TRP, TIS, & Reference Measurement frequency changes – Sections 5.1.1.2, 5.1.2.2, 5.2.1.2, 5.2.2.2, Table 5.2.5, 6.1.1.2, 6.1.2.2, 6.2.1.2, 6.2.2.2, Table B2, Table B3, Table B4, Table B5, Table B6, Table B7, New Appendix D</p> <p>Other sections changed: Table B1 - CID Added, section 1.4 - CTIA Reference updated, Table A1 Channel change UTRA FDD Band I - IV, 4120/824.0 changed to 4132/826.4, Table B3 Reference changed from (2) to (1), Table 5.1.1 and table 6.1.1 - removed "Check TX Mask" from comments column</p>
June 2009	1.3	<p>Added footnote to Section 2.1, 2nd sentence.</p> <p>Added text to Section 4.1, 2nd sentence.</p> <p>Added CTIA Request # to Appendix B table.</p> <p>Added Appendix E Device Capabilities Testing Matrix</p>
February 2015	2.0	<p>Added 802.11n</p> <p>Added LTE and TD-SCDMA protocols</p> <p>Updated cellular and Wi-Fi desensitization sections</p> <p>Updated Appendix B Device Capabilities Test Matrix, removed right hand and added right and left hand phantoms</p> <p>Added Appendix C – Radio Access Technologies that require testing, but are not covered in the CTIA Certification OTA Test Plan [1].</p> <p>Added Appendix D - Notebook and Tablet PC Requirements</p> <p>Added Appendix E - WLAN-LTE emulator test equipment notes when testing DUTs that support LTE band 40 or 41 (Informative)</p>

Date	Version	Description
		<p>Added Appendix F - Table of Wi-Fi Radio channels interfered by cellular radio harmonics</p> <p>Revised Wi-Fi test procedure Sections 3.1, 4.1, 4.2 & 4.3</p> <p>Updated the Acknowledgements list</p> <p>Updated Section 4.1.3 Measurement Frequencies for Radiated tests</p> <p>Updated Table 2 parameters</p> <p>Split Table 3 to Table 3 and Table 4 for TX and RX and also changed RX parameters</p> <p>Updated Section 2.1</p> <p>Replaced WLAN with Wi-Fi thought out the document as appropriate</p> <p>Revised Section 2.2 to specify PING as the primary mode for packet generation</p> <p>Revised Tables 17 and 18 to replace DER with Pass/Fail info on Intermediate Channels</p> <p>Updated title and introduction text of Appendix A</p> <p>Updated Table 12 consistent with the test case requirements of Section 4.6 and 4.17</p> <p>Updated Appendix F to include Wi-Fi desensitization matrix</p> <p>Reference Polarization columns added to all Appendix A tables that include Reference Position information</p>
July 2015	2.0.1	<p>Modified document reference in 5th paragraph of Section 2.2.</p> <p>Updated RAT Channel Number and RAT Uplink Frequency columns in Table 4-5</p> <p>Updated channel for UNII Low, Middle and Upper Bands in Table A-5 and Table A-6.</p> <p>Deleted first sentence of Appendix A.3.</p> <p>Added text to section 1.6.2.</p> <p>Removed stray text in Table A-2.</p> <p>Fixed cross-references</p>
October 2015	2.0.2	<p>"Draft 1" removed from the footnote</p> <p>Publication and footnote dates updated based on CTIA format</p> <p>Tables A-7 and A-8 modified to include a field for Lab comments on maximum EIS</p> <p>Modified Section 2.2 to provide explicit guidelines for PING method for 802.11n</p> <p>Applied other purely editorial changes to the titles in Appendices sections and tables</p> <p>Removed "(WI-FI U-NII MIDDLE BAND)" from the titles and references to Channel 60 in Tables A-10 and A-12</p> <p>Requirement for usage of Hand Phantoms is clarified in Appendix B</p>

Date	Version	Description
September 2016	2.0.3	<p>Modified Appendix B text regarding usage of Hand Phantoms.</p> <p>Added reference table for Wi-Fi radio desensitization by closest cellular uplink frequency in Section 4.2.4. Examples corrected.</p> <p>Updated CTIA logo and Wi-Fi Alliance logo.</p> <p>Applied purely editorial correction throughout document.</p> <p>Applied changes to Section 2.1 regarding adaptive power control and regulatory domain (country code) setting.</p> <p>Applied further modifications to Section 4.2.4.</p> <p>Updated Table numbering in Section 4.</p> <p>Table B-1 modified to cover testing applicability for devices with and without WWAN simultaneous operation capability.</p> <p>Applied purely editorial changes to Sections 4.2.4 and 4.2.5.</p> <p>Clarification made in Section 3.1.5 regarding traffic generation.</p> <p>Table B-1 was reformatted without change in the content.</p> <p>Corrected Item 44.6 LTE Band 38 Channel Number and some references in Table 4-6.</p> <p>Editorial changes applied throughout document.</p> <p>References in Section 4.1 was updated/corrected.</p> <p>Applied further corrections to Table 4-6.</p> <p>Updated Appendix F.</p> <p>Updated Acknowledgement table.</p>
January 2019	2.1	<p>Applied changes throughout document to cover 802.11ac</p> <p>Applied changes throughout document to make CTIA Certification OTA Test Plan as the basis</p> <p>Updated reference to latest release of IEEE 802.11 (IEEE Std. 802.11-2016)</p> <p>Updated Section 4.1.4 & 4.3.2 as related to support for multiple Wi-Fi TX antennas</p> <p>Updated Section 4.1.5 as related to support for Antenna Switched RX Diversity for Wi-Fi</p> <p>Updated Section 4.2.3 as related to support for multiple cellular TX antennas</p> <p>Coverage for TD-SCDMA was added to Section 4.2.3, 4.3.4</p> <p>Corrected Table 4.2-3 for CDMA 1800 BC 15</p> <p>Reference to OTA Test Plan Appendix O.3, O.4 and O.5 added to Section 4.3.3, 4.3.4 and Appendix D to enable support for reduced legacy RAT testing for TIS and/or intermediate channel testing in free-space</p> <p>Section 4.3.4 title and content updated to properly cover Test Procedure for RATs without Free-Space Limits</p> <p>A new sub-band column added to Table A- 1; rows updated to make the report template complete</p> <p>Appendix guidelines related to Notebooks, Tablets, Convertible PCs and Hybrid PCs testing in their primary mechanical mode was added to Appendix D</p>



Date	Version	Description
September 2020	2.2	<p>Changed EUT to DUT throughout the document.</p> <p>Updated Wi-Fi Sub Band titles and related regulatory domains throughout document.</p> <p>Reformatted Wi-Fi Sub-band tables throughout document.</p> <p>In Section 1.4, Added references for FCC and ETSI for 5 GHz sub-bands.</p> <p>In Section 1.6.2: updated measurement uncertainty requirements for 2.4 and 5 GHz bands.</p> <p>In Section 1.6.3: updated minimum measurement distance requirements for 2.4 and 5 GHz bands.</p> <p>In Section 3.1, added Table 3.1-1 Measurement Frequencies For Conducted Tests.</p> <p>Clarified/corrected Section 4.1.5 Note on Note on Alternative TIS Test Procedures as specified in Section 6.15.4.</p> <p>Clarified/corrected Section 4.1.6 text as related to the Alternate Test Procedures specified in CTIA Certification OTA Test Plan Section 5.11.1 Single Point Offset Test or 5.11.2 Multi-point Offset Test.</p> <p>Clarified/corrected Section 4.1.7 text as related to the Alternate Test Procedures specified in CTIA Certification OTA Test Plan Section 6.15.1 Single Point Offset Test or 6.15.2 Multi-point Offset Test.</p> <p>In Section 4.2, removed all references to Wi-Fi Channel 14.</p> <p>Table 4.2-3 Desensitization Cases: Updated test case 44.5; added LTE band 66 as test case 44.8.</p> <p>Appendix B: updated hand phantom selection guidelines.</p> <p>Updated Appendix F Table of Wi-Fi Radio channels interfered by Cellular Radio Harmonics contents and Wi-Fi Sub-band labels and removed references to Wi-Fi Channel 14.</p>
April 2021	2.2.1	<p>Updated CTIA Certification URL</p> <p>Added Wi-Fi Alliance application option to "Use Instructions"</p>
February 2023	4.0.0	<p>Added Single Carrier 5G NR FR1 (SISO) to scope, throughout relevant sections in particular Sections 4.2 and 4.3</p> <p>Added 802.11ax (SISO) to scope, throughout relevant sections in particular Sections 3.1, 3.2, 4.2 and 4.3.</p> <p>Added coverage for 6 GHz and 5.9 GHz Wi-Fi bands to test cases in various Sections 3.1, 3.2, 4.2 and 4.3</p> <p>Updated Appendix F and Section 4.2.6 Wi-Fi Radio Desensitization by Cellular Radio Uplink Harmonics to include new test cases added to v4.0.</p> <p>Removed WCDMA Band IV and TD-SCDMA from scope and throughout the document.</p> <p>Updated references to the CTIA Test Plan for Wireless Device Over-the-Air Performance Suite v4.0 and IEEE 802.11-2020 and 802.11ax and cross references throughout the document.</p> <p>Removed Appendix C Radio Access Technologies that Require Testing, but are not Normative in the CTIA Certification OTA Test Plan.</p>

Date	Version	Description
April 2024	6.0.0	<p>Definition of “Module” in Section 1.8 was revised according to align with that of CTIA OTA Test Plan and PTCRB.</p> <p>In Table 3.1-1, the Wi-Fi frequency range mapped to major regulatory bodies here and removing all other references to sub-bands. This way, if in the future, we would like to add a regulatory body, will only add it to this table.</p> <p>Added 2.4 GHz Channel 13 to Table 3.1-1 and applied modifications to the test plan so that only highest supported channel (for example, channel 11 or channel 13) is tested.</p> <p>Modified Section 3.1.3 and Table 3.1-1 to remove high and low channels and only require middle channel for US-NII-4 conducted measurements.</p> <p>Modified Tables 3.1-1 and 4.1-1 to Included straddle Channel 185 as assigned to U-NII-8 band.</p> <p>Modified Section 3.1.3 and Table 3.1-2 to remove low data rates from Rx Test Data Rates for Conducted Testing.</p> <p>In Wi-Fi TRP/TIS Test Section 4.1 clarified that the downlink power step size shall be no more than 1 dB when the RF power level is near the target sensitivity level.</p> <p>In Wi-Fi Radio Desensitization by Closest Cellular Uplink Frequency Section 4.2.5 updated cellular uplink channels and parameters.</p> <p>Updated cellular channels and parameters in Table 4.2-3 Desensitization Cases.</p> <p>Updated Section 4.3.5 to include test cases of Section 4.3.6 and removed Section 4.3.6.</p> <p>Updated Section 4.3.5 to include all applicable test channels (reference or intermediate).</p> <p>Updated Appendix A to fix errors and include missing test cases and Test IDs.</p> <p>Added Appendix A.7 Machine Readable Report field descriptions.</p>
November 2024	7.0.0	<p>Updated Table 4.2.5-1 Closest Channel Combinations</p> <ul style="list-style-type: none"> Updated RAT Uplink Frequencies to Center Frequencies. Added Columns SCS (kHz), Total RBs, UL RB # and UL RB start Corrected frequency gap for WCD1.4. <p>Updated Table 4.2.6-1 Desensitization Cases</p> <ul style="list-style-type: none"> Test Case NR FR1 n70 removed as it was a 4th order harmonic. Added missing n26/n30/n48 test cases. Added NR FR1 n77(R2) and n77(R3). Updated NR FR1 Frequencies and Channel Numbers. Test cases reordered to be in increasing order of Wi-Fi Channels. Center frequency of some LTE bands corrected. Corrected UL center frequencies of some of LTE test cases based on UL channel numbers. Updated RAT Uplink Frequencies to Center of UL RB allocation. Replaced Special Setup Column with 7 columns: SCS, Total RBs, UL RB #, UL RB start, Harmonic Order, Harmonic Freq (MHz), Frequency Gap. Added “Cellular Channel Bandwidth” column <p>Updated references to Main OTA in Test Procedures in Sections 4.3.4 and 4.3.5</p> <p>Updated Appendix F consistent with updated in Tables 4.2.5-1 and 4.2.6-1</p>