



Wireless Device Grading Scales Criteria and Definitions

Version 3.0

September 2023

© 2018 - 2023 CTIA Certification. All Rights Reserved.

Any reproduction, modification, alteration, creation of a derivative work, or transmission of all or any part of this publication, in any form, by any means, whether electronic or mechanical, including photocopying, recording, or via any information storage and retrieval system, without the prior written permission of CTIA Certification, is unauthorized and strictly prohibited by federal copyright law. This publication is solely for use within the CTIA Certification Program. Any other use of this publication is strictly prohibited unless authorized by CTIA Certification or its assigns in writing.

CTIA Certification LLC
1400 16th Street, NW
Suite 600
Washington, DC 20036

1.202.785.0081

programs@ctiacertification.org



Acknowledgements

This document was created by the wireless industry with input from the following companies and their representatives:

Company, Representative	Company, Representative
Apple , Randy Teele	Ingram Micro , Ron Wacker, Steven Wartell
Apkudo , Don Riley	Injured Gadgets , Shay Kripalani
Allstate , AJ Forsythe, Guennaël Delorme	Luna Systems , Israel Quintal
Assurant , Shelley Binkley, Bill Pickering	Mobile Defenders , Steve Barnes, Jordan Notenbaum
Asurion , Justin Nelson, Cale Turner	Mobile reCell , Michael Cook
Asfalis Warranty , Roger High, Antoinette Norton	Motorola Mobility LLC , Darwin Garcia
AT&T , Kimberley Allison, Keith Burkman, Brandon Graham	Nexus Cellular , Bajwa Irfan
B-Stock Solutions , Sean Cleland	PCS Wireless , Anthony Yadron, Alexandra Amrami
Batteries Plus Bulbs , Danyelle Kukuk, Sukaina Yacoob	Phoenix Innovations , Amit Mahajan
Blackbelt Defence , Sai Kumar	Phobio , Jacob McMillan
Blanco , Andrew Kroeger	PrologMobile , Jon Newman
Cellpoint Corporation , Ehsan Gharatappeh,	QuickShip Brands , Jordan Insley
Clover Wireless , Tony Vitek	Recipero , Jack McArtney
Comcast , Cornelius VanGinhoven	Reconext , Brian Mantel
CPR , Ben Davies	Samsung , Paul Walker
ecoATM , Larry Worden	Securaze , Andrew Kroeger
Encore Repair , Sean Flaherty, Josh Geller	ServiceCentral Technologies , Chris Bleess
FedEx Supply Chain , Tevon Taylor	Shine Electronics , John Im
Future Dial , Dennis Pettit, Chris Elias	Sprint , Brian Mantel
Global Resale , Mike Watson	Staymobile , Rob Lennox
HOBi International , Timothy Wagner	T-Mobile , Patricia Arnold, Kevin Sweeney
Hyla Mobile , Steve Pappas	United Smart Tech , Amir Noorani, Asif Noorani
iFixYouri , Chris Johncke	U.S. Cellular , Jeong Lee, Edna Roberts, Tom Orlando
	Werx Parts , Robert Garza

Table of Contents

Section 1	Introduction	7
1.1	Purpose	7
1.2	Scope.....	7
1.3	Definitions	7
1.4	References	8
Section 2	Grading Scales	9
2.1	Schema.....	9
2.2	Cosmetic Grade Definitions.....	9
2.3	Surface Area Definitions	11
2.4	Defect Definitions Surface	22
2.5	Viewing and Inspection.....	24
2.6	Defect Levels for Scratch and Dots	25
2.7	Cosmetic Surface Area Classification	28
2.8	Functional Classifications	30
2.9	Lock Status	31
2.10	RF Grading Scale	32
2.11	Kit Configuration	32
Section 3	Grading Scales Matrix: Cosmetic Grading Scales Cross Reference with Functional Classification.....	33
3.1	Cosmetic Grading Scales Cross Reference with Functional Classification	33
Section 4	Simplified Cosmetic Grading Classification for Wearables	34
Appendix A	Revision History	35

List of Figures

Figure 2.2-1 Camera Lens Zoom View	10
Figure 2.2-2 Top to Bottom Side View of Display Assembly	11
Figure 2.3-1 “AA” Surface Camera Example for Smartphones	12
Figure 2.3-2 “AA” Surface Camera Example for Tablets	12
Figure 2.3-3 “AA” Surface Example for Wearables	13
Figure 2.3-4 “AA” Surface Example for Foldable Devices	13
Figure 2.3-5 “A” Surface Example for Smartphones and Tablets	14
Figure 2.3-6 “A” Surface Example for Wearables	14
Figure 2.3-7 “A” Surface Example for Foldable Devices	15
Figure 2.3-8 “B” Surface Example for Smartphones	16
Figure 2.3-9 “B” Surface Example for Tablets	16
Figure 2.3-10 Side View of Tablets	17
Figure 2.3-11 Right and Left View of Tablet	18
Figure 2.3-12 “B” Surface Example for Wearables	19
Figure 2.3-13 Audio Mesh Grill and Microphone Holes on Smartphone	19
Figure 2.3-14 “B” Surface Example for Foldable Devices	20
Figure 2.3-15 Flip View and Side View of Foldable Devices	20
Figure 2.3-16 USB Connector	21
Figure 2.3-17 Lightning Connector & USB-C Connector	21
Figure 2.3-18 Headset Connector	21
Figure 2.3-19 SIM Tray Inside Surface	21
Figure 2.3-20 Battery Contacts for Customer Removable Battery	22
Figure 2.3-21 “C” Surface Example for Wearables	22
Figure 2.6-1 Viewing and Inspection	26
Figure 2.6-2 Lighting	26
Figure 2.6-3 Measurement Tool	27

List of Tables

Table 1.3-1 Definitions	7
Table 2.1-1 Grading Scales Categories	9
Table 2.6-1 Defect Levels	25
Table 2.6-2 Dot Creation and Inspection	25
Table 2.7-1 Cosmetic Grading Scales: Defect by Surface Area Table	28
Table 2.8-1 General Descriptions of Common Failures	30
Table 2.8-2 Functional Classifications	30
Table 2.8-3 Battery Health Thresholds	31
Table 2.9-1 Customer Lock Status	31
Table 2.9-2 Enterprise and Operator Lock Status	31
Table 2.10-1 RF Test Grading Scale	32
Table 2.11-1 Kit Configuration	32
Table 3.1-1 Example Grading Scale Matrix	33
Table 3.1-1 Example Wearable Simplified Cosmetic Grading	34

Section 1 Introduction

1.1 Purpose

This document defines the wireless industry common lexicon and process for grading wireless devices. The intention of this document is not to identify specific requirements for operationalizing grading scale tiers. Any business can modify the grading scale tiers and defect sizes or types per surface area to meet their business needs, including establishing bulk lots for resale. Any deviations from these grading scale criteria and definitions shall be disclosed to the customer to prevent confusion with the standards defined herein.

1.2 Scope

The scope of this document is limited to devices as defined in [Table 1.3-1](#).

1.3 Definitions

Table 1.3-1 Definitions

Term	Definition
Customer Lock	Customer initiated lock like FMIP (Find My iPhone) for iOS, Find My Device for Android or a simple screen lock.
Device	Smartphone, feature phone, tablet, wearables, fitness trackers
Enterprise Lock	Device is locked by security services commonly needed for security management of mobile devices as defined in NIST Guidelines for Managing the Security of Mobile Devices in the Enterprise .
Fully Functional	Device assured functional to all original applicable OEM specifications.
LDI	Liquid Damage Indicator
OEM	Original Equipment Manufacturer
Operator Lock	Device is locked by the network operator (example; AT&T, T-Mobile, or Verizon) to only work on one network/carrier or only accept SIM cards from one network/carrier.
PCBA	Printed Circuit Board Assembly
RF	Radio Frequency
SIM	Subscriber Identify Module
USB	Universal Serial Bus

1.4 References

[1] NIST: Guidelines for Managing the Security of Mobile Devices in the Enterprise, Revision 1, June 2013

[2] European Commission, Annexes to the Commission Regulation, laying down ecodesign requirements for mobile phones, cordless phones and tablets pursuant to Directive 2009/125/EC of the European Parliament and of the Council, August 2022

Section 2 Grading Scales

2.1 Schema

An industry Grading Scales schema is defined in order to allow any seller in any secondary market of devices to universally identify cosmetic condition, functional classification, data status, lock status and kit configuration condition. [Table 2.1-1](#) shows the Grading Scales options that define the schema.

Table 2.1-1 Grading Scales Categories

Description	Table Reference	Grading Scales Options
Cosmetic Grades	Table 2.7-1	A, B, C, D, E or N
Functional Classification	Table 2.8-2	0, 1, 2, 3, 4, 5, 6, 7, 8 or 9
Customer Lock Status (As Applicable)	Table 2.9-1	1, 2, 3, 4, 5
Enterprise and Operator Lock Status (As Applicable)	Table 2.9-2	1, 2, 3, 4, 5
RF Test Grading Scale (As Applicable)	Table 2.10-1	1, 2, 3, 4 or 5
Kit Configuration	Table 2.11-1	1, 2, 3, 4, 5 or 6

2.2 Cosmetic Grade Definitions

Grade A: Like new condition

- Minimal scratches and blemishes
- External LDI not triggered

See [Table 2.1-1](#) for details on quantity and types of cosmetic defects allowed per surface area and in total.

Grade B: Light wear and tear

- Will allow more scratches and blemishes than Grade A but no lens cracks on any surface
- External LDI not triggered

See [Table 2.7-1](#) for details on quantity and types of cosmetic defects allowed per surface area and in total.

Grade C: More aggressive wear and tear

- Will allow some cracks on certain surface areas such as camera lens, rear lens but not on display cover lens

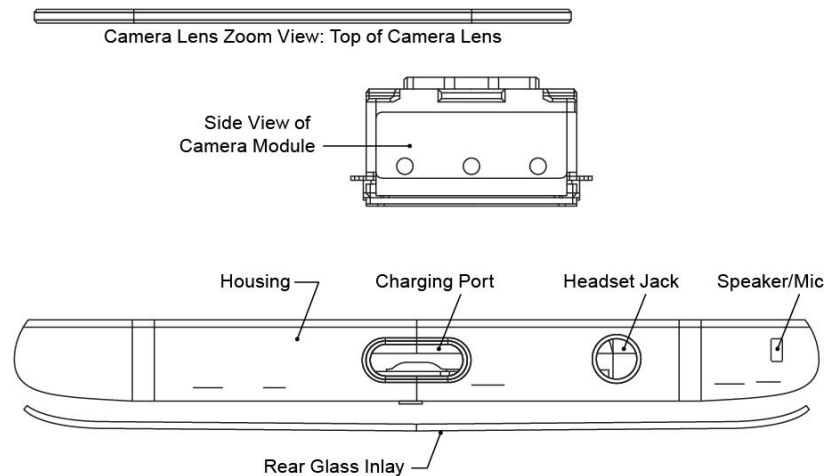

Figure 2.2-1 Camera Lens Zoom View

- Externally viewable LDI not triggered

See Table 2.7-1 for details on quantity and types of cosmetic defects allowed per surface area and in total.

Grade D: Heavy cosmetic damage with cover lens cracks.

- Will have excessive damage on multiple surface areas and cracks on the cover lens but not on internal display structure
- Missing small parts such as side keys, finger print sensor, speakers, flexes, front camera, daughter boards, camera/flash lens and internal mechanical parts (Display, PCBA, Main/Rear Camera, Housing and Battery not consider small)
- Externally viewable LDI triggered but no corrosion

See [Table 2.7-1](#) for details on quantity and types of cosmetic defects allowed per surface area and in total.

Top to Bottom Side View of Display Assembly

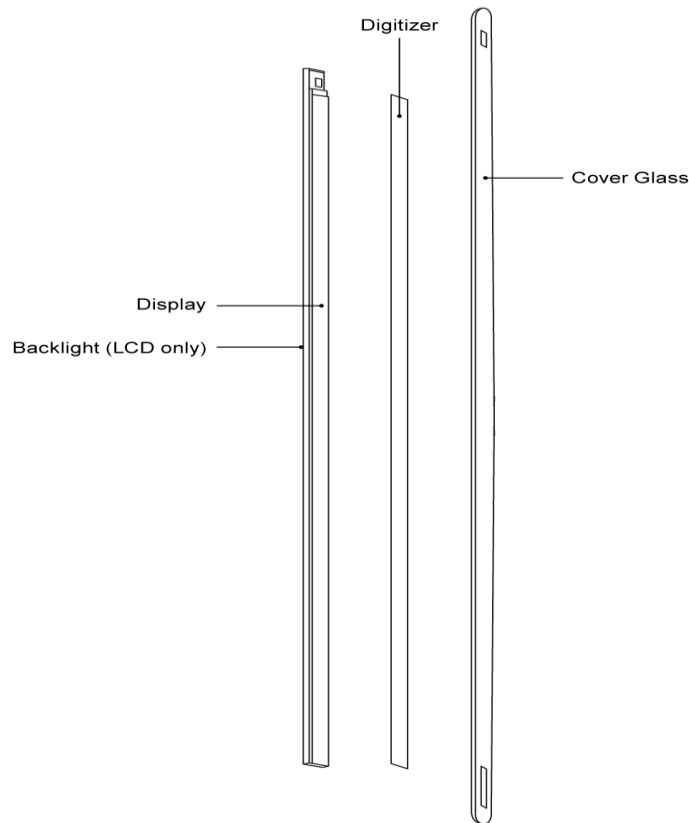

Figure 2.2-2 Top to Bottom Side View of Display Assembly

Grade E: Heavy cosmetic damage with display internal structure damage.

- Will have excessive damage on multiple surface areas including internal display structure
- Externally viewable LDI triggered with or without corrosion

See [Table 2.7-1](#) for details on quantity and types of cosmetic defects allowed per surface area and in total.

Grade N: Not Graded.

- Device was not inspected for cosmetic defects
- Device has unknown cosmetic defects

2.3 Surface Area Definitions

During the visual inspection of a device evaluated for disposition, it is important to have an understanding of the industry defined surface areas and external, internal and connecting components of a device. These external surface areas are defined in this section:

“AA” Surface - Main (any) display and all camera lenses

- Main lens over the display *All displays if multiple displays
- Display viewing area *All displays if multiple displays
- Camera lens *All cameras if multiple cameras

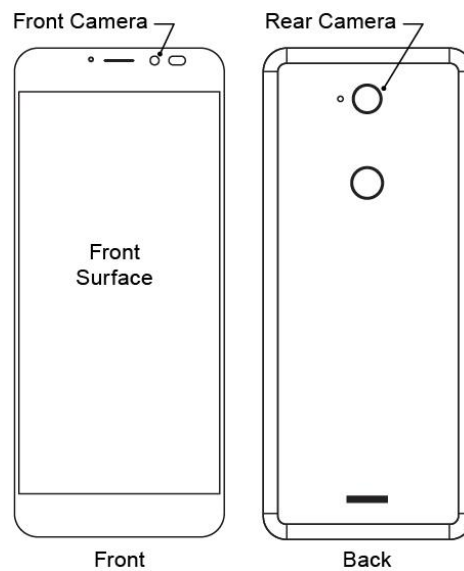

Figure 2.3-1 “AA” Surface Camera Example for Smartphones

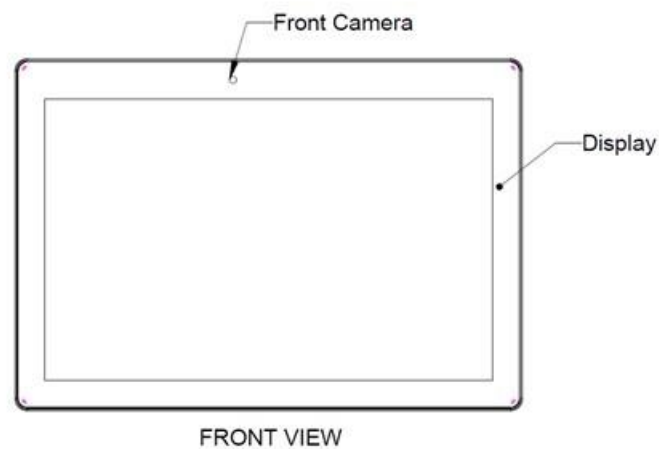

Figure 2.3-2 “AA” Surface Camera Example for Tablets

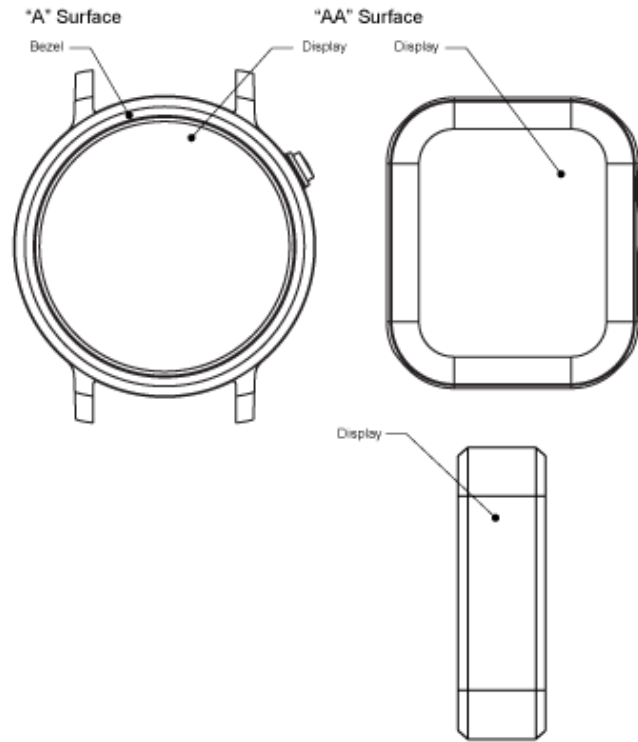

Figure 2.3-3 "AA" Surface Example for Wearables

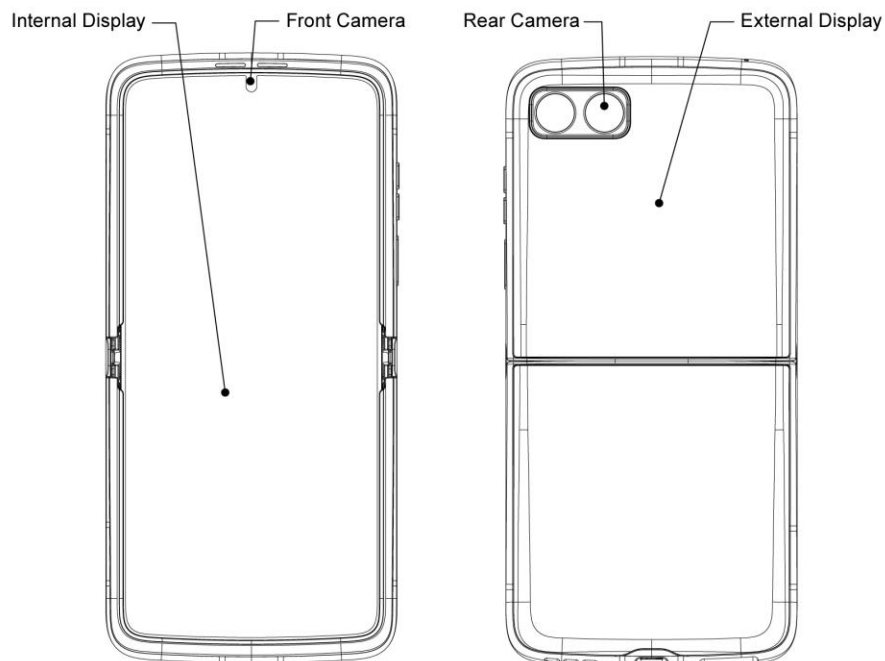

Figure 2.3-4 "AA" Surface Example for Foldable Devices

Note: Internal displays with replaceable screen protectors applied by the manufacture can be reclassified as "B" surface if the dents and scratches do not propagate to the internal displays.

“A” Surface - Front housing/glass area, not including display or camera

- Front housing – only the surface areas visible when looking directly at device if not part of the back housing
- Any surface area front view that isn't a “AA” surface
- Finger print sensor

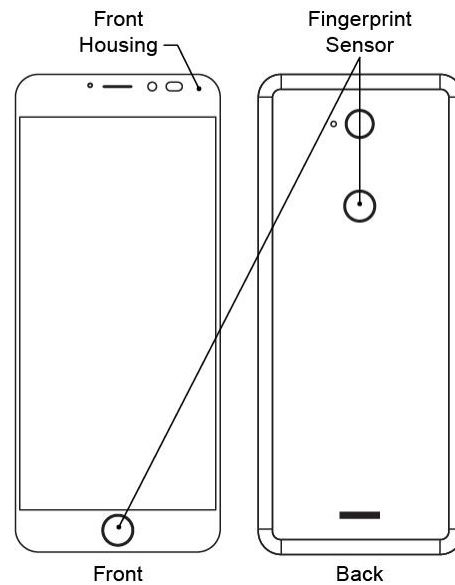

Figure 2.3-5 “A” Surface Example for Smartphones and Tablets

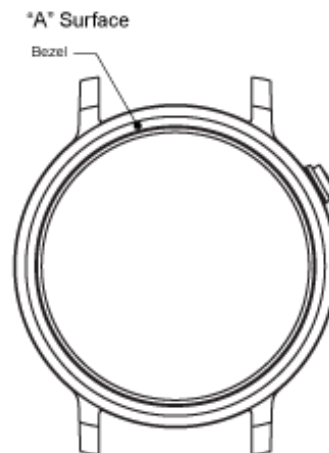

Figure 2.3-6 “A” Surface Example for Wearables



Figure 2.3-7 : "A" Surface Example for Foldable Devices

"B" Surface - Sides and back of housing

- Housing – sides/edges/corners/back
- SIM tray cosmetic area
- Logos
- Battery cover/door
- Side keys/buttons
- USB port area
- Headset port area
- Audio mesh grill and microphone holes
- Screws (directly visible on any external surface area)
- Other cosmetic surfaces (bezels, antennas, stylus, etc.)

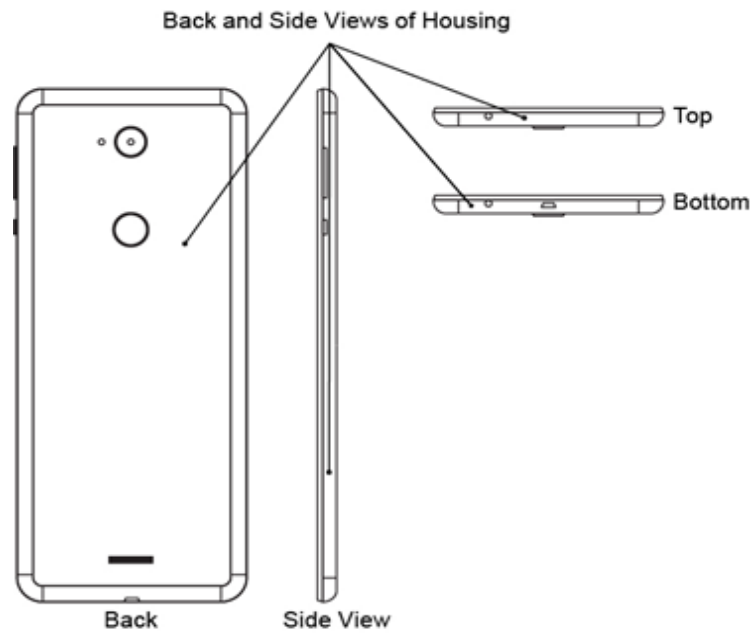

Figure 2.3-8 "B" Surface Example for Smartphones

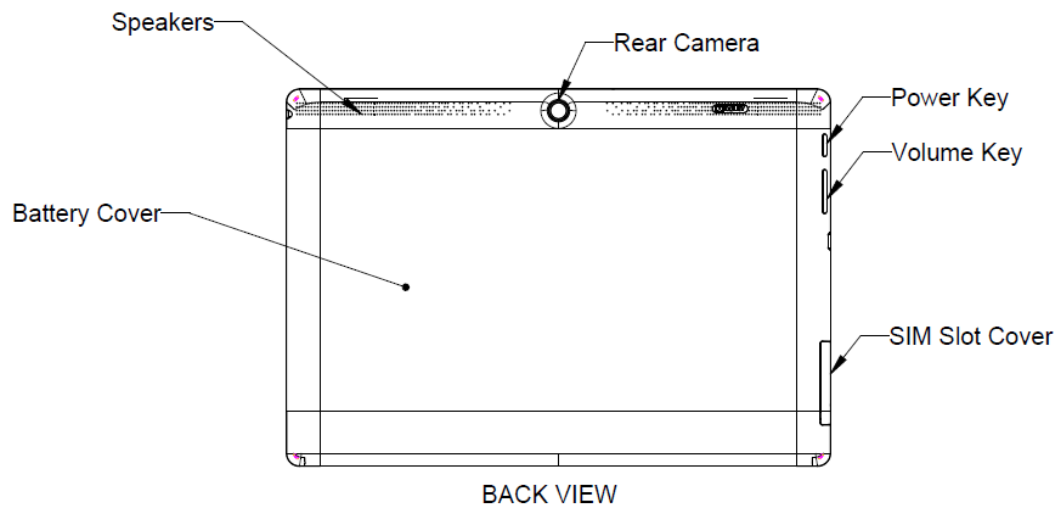

Figure 2.3-9 "B" Surface Example for Tablets

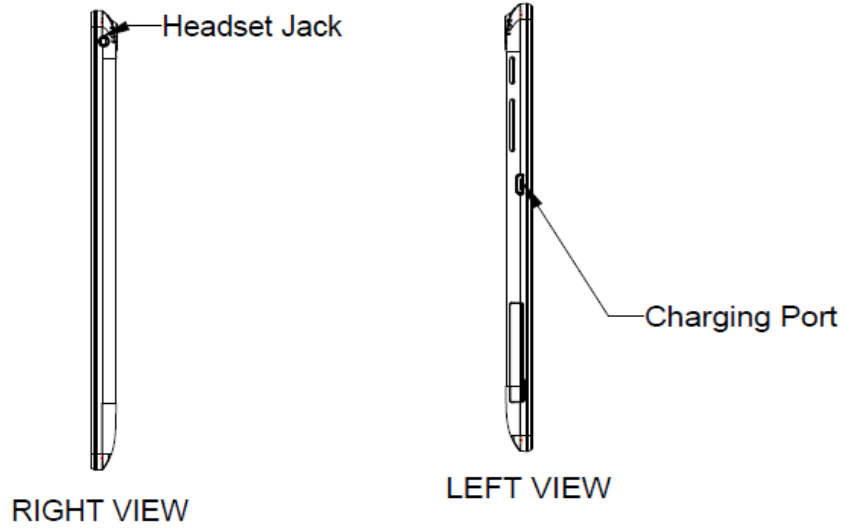
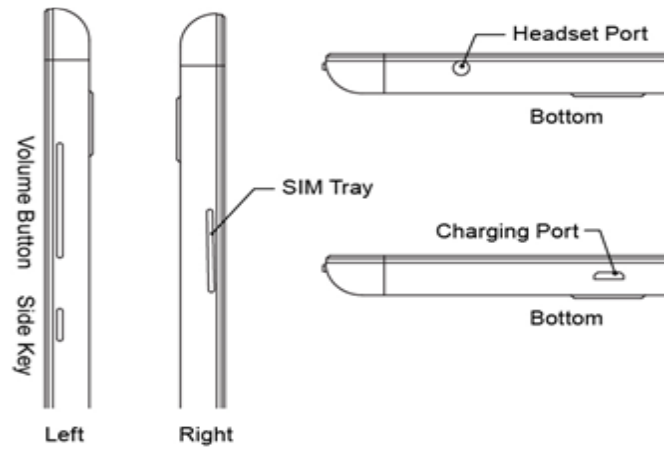

Figure 2.3-10 Side View of Tablets

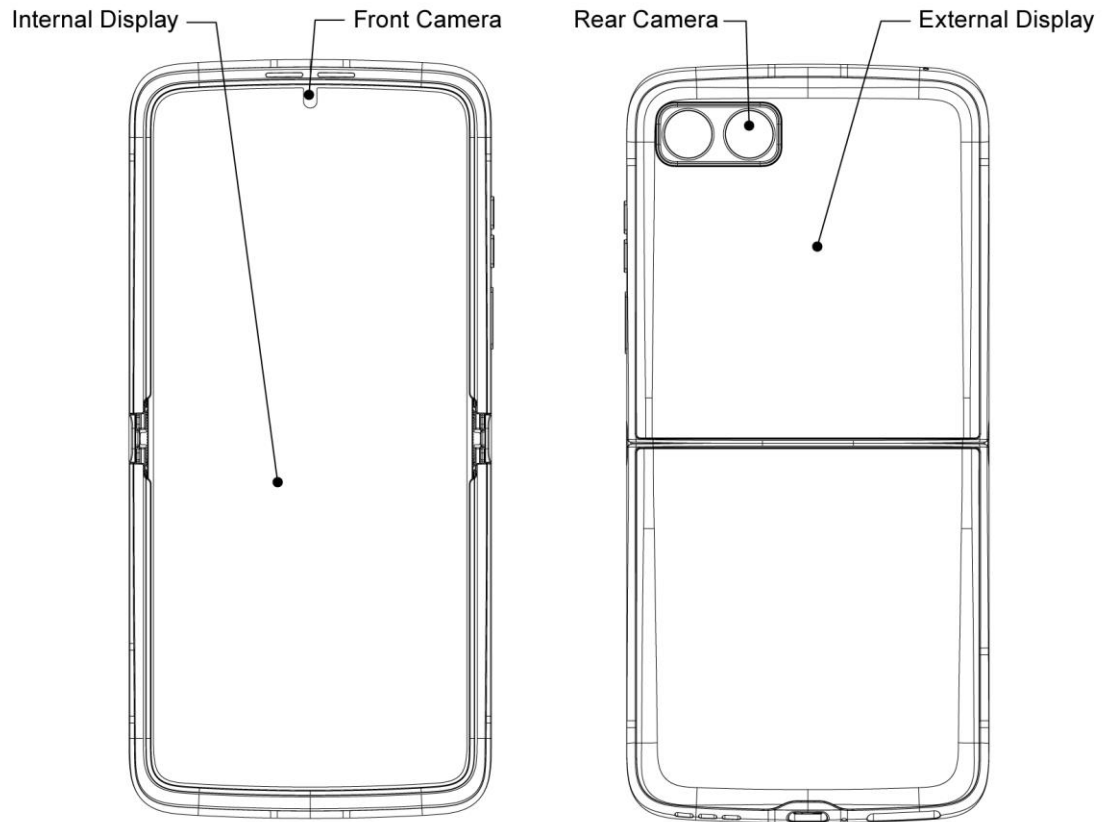

Figure 2.3-11 Right and Left View of Tablet

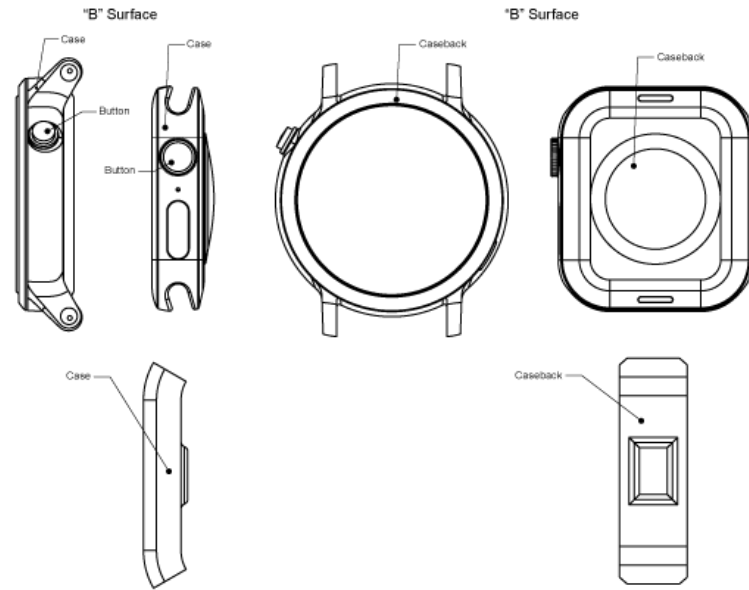

Figure 2.3-12 "B" Surface Example for Wearables

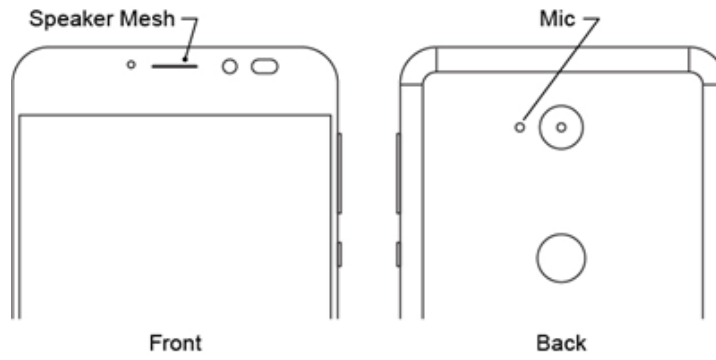

Figure 2.3-13 Audio Mesh Grill and Microphone Holes on Smartphone



Figure 2.3-14 "B" Surface Example for Foldable Devices

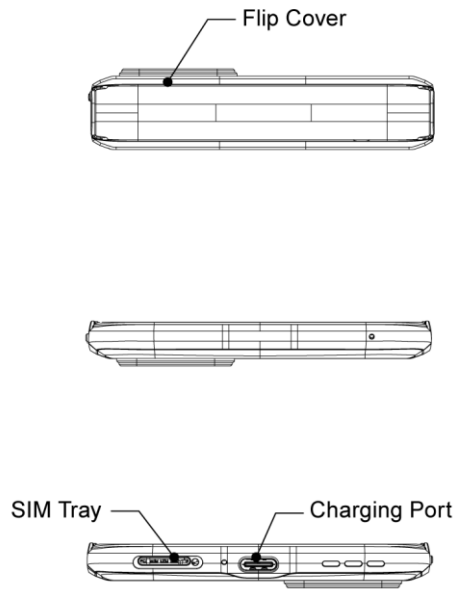

Figure 2.3-15 Flip View and Side View of Foldable Devices

“C” Surface - Contacts/connections/under covers

- Internal labels and logos (under a customer removable cover/door)
- Surfaces covered by the customer removable battery cover
- Screws covered by the customer removable battery cover
- External battery (user replaceable)

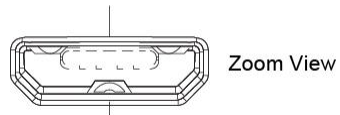

Figure 2.3-16 USB Connector



Figure 2.3-17 Lightning Connector & USB-C Connector

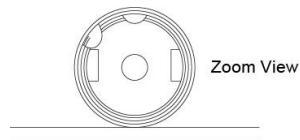

Figure 2.3-18 Headset Connector

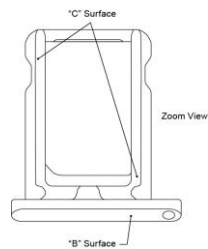

Figure 2.3-19 SIM Tray Inside Surface

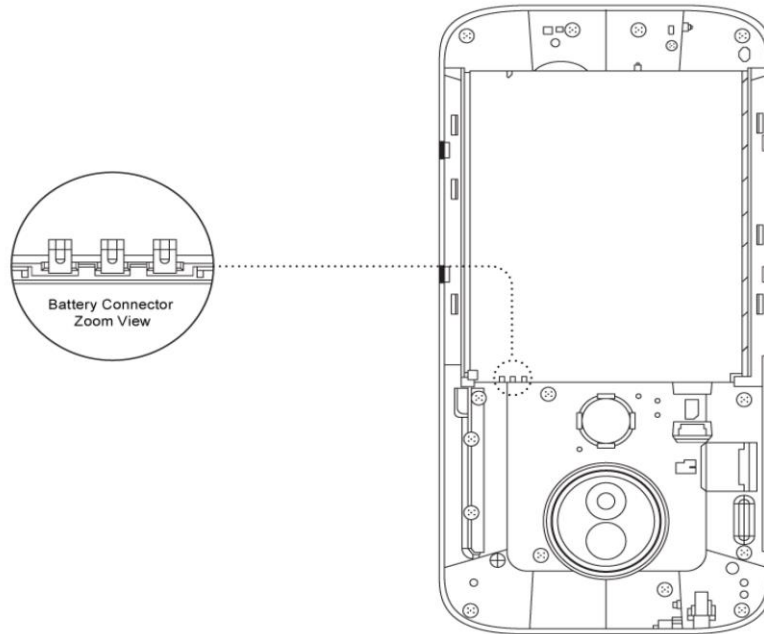

Figure 2.3-20 Battery Contacts for Customer Removable Battery

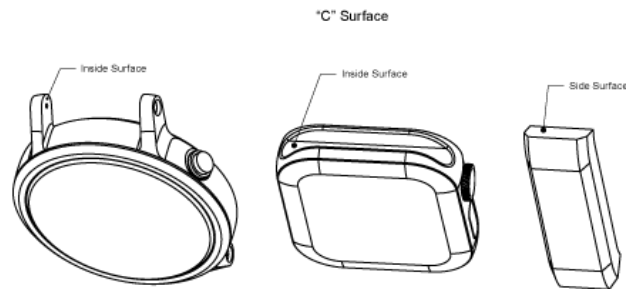

Figure 2.3-21 "C" Surface Example for Wearables

2.4 Defect Definitions Surface

"AA" Surface: Main display(s) and all camera(s) lenses

- Scratch and Dots: Elongated and/or round marks on the surface of the device
- Crack: A physical fracture in the surface of the material; glass that has broken or is starting to break
- Fingerprints under glass/lens: Skin oils or impressions from handling the lens and display during the repair/refurbishment process
- Foreign Material: Dust or other matter inside main, camera or flash lens

- Pressure Spot: Permanent damage in screen that display as Shadows on the screen, bruises or discoloration spots
- Lint: Hair and fibers found behind main, camera or flash lens
- Smudge: Permanent stain or blotch on the main, camera or flash lens
- Alignment: Display to lens viewing area is aligned and centered
- Air Bubble: Air entrapment within and between the display and lens
- Lifted lens: Lens to housing dimension out of spec. (de-lamination or separation gaps)
- Air Entrapment in Foldable Devices: Bubbles between the internal display and housing
- Stretch marks in the internal display for foldable devices
- Internal display delamination or bleeding

Note: Any imperfection with the screen protector (*installed by the manufacturer*) or waves in the folding area is not considered a defect.

“A” Surface: Front of device

- Scratch and Dots: Elongated and/or round marks on the surface of the device
- Crack: A physical fracture in the surface of the material; glass that has broken or is starting to break
- Lifted lens: Lens to housing dimension out of spec. (de-lamination or separation gaps)
- Discoloration: Any change from original color and inconsistent gloss
- Dent: Indentation or nick that can be felt to the touch
- Shiny Blemish: A smoothness in the texture of the plastic, usually wide and cannot be felt
- Stains: Foreign colorant, corrosion, rust or oxidation
- Warp: Deformation of plastic housing by bowing across flat plane
- Gaps: Gaps between surfaces within specs

“B” Surface: Back and side of housing

- Includes all defects as defined above from “A” Surface Area
- Burr: Rough edges and sharp corners
- Dusted Mesh: Dust or other matter inside mesh or microphone port
- Screw Defect: Missing, wrong type, stripped head and loose
- Defects on the replaceable screen protectors (applied by the manufacturer)
- Missing replaceable screen protectors
- Hinge can’t fully close or open for foldable devices
- Loose hinge or overextended hinge for foldable devices
- Contamination in the hinge of foldable devices that prevents a smooth opening or closing
- Excessively noisy hinge for foldable devices

“C” Surface: Connectors and undercovers

- Contaminated Connector: Foreign material inside the connector
- Damage Connector: Missing, bent, corrosion and excessive wear and tear
- Battery Damage (customer removable): Warped, burned, punctured, swelled, wrinkle and missing labels
- SIM Tray Damage: Bent and loose (cannot hold SIM or SD card)
- Glue: Residue left after removing or peeling off labels
- Damage Labels: Peeling, missing. Must be fully legible

2.5 Viewing and Inspection

1. Visual inspection is performed at arm’s length with slight bend in elbow (18 inches from face to device) with normal 20/20 vision (or corrected to 20/20 vision).
2. The unit should be viewed straight on and without having to rotate the unit to determine a defect.
3. Inspection is performed in lighting typically found in a factory environment. The type and degree of lighting is technically described as a cool, white, fluorescent light source. A minimum of 500 lumens is recommended.
4. Each surface of part shall be scanned once without dwelling on any single surface (4 seconds for each surface area and 6 seconds for “AA”). Magnification is allowed only for verification of defect size. Use of tools/gauges is encouraged to aid in acceptance decisions.
5. “AA” surface should be tilted back 45 degrees to help identify all cracks/scratches in the surface.





2.6 Defect Levels for Scratch and Dots

Table 2.6-1 Defect Levels

	Length in Millimeters	Width in Millimeters	Length in Inches	Width in Inches
LEVEL 1	≤ 0.5mm	≤ 0.05mm	≤ 0.02 inch	≤ 0.002 inch
LEVEL 2	≤ 1.5mm	≤ 0.5mm	≤ 0.06 inch	≤ 0.02 inch
LEVEL 3	≤ 2.0mm	≤ 0.5mm	≤ 0.08 inch	≤ 0.02 inch

Note: Any defect greater than the measurements defined as a Level 3 Defect is classified to a Grade D or below.

Table 2.6-2 Dot Creation and Inspection

Dot Criteria		Dot Inspection
Max Dot Size	1 Dot ≤ 0.5mm each	Imperfections of various shapes  Inspection Dot   Pass: Imperfection is smaller than the inspection dot  Fail: Imperfection is larger than the inspection dot Note: Dots are not to scale
Cumulative Dots Rule	2 Dots ≤ 0.4mm each	
Max Cumulative Dots	1 Dot + 1 Dot ≤ 0.8mm	
Marginal/Questionable	Use Magnification	

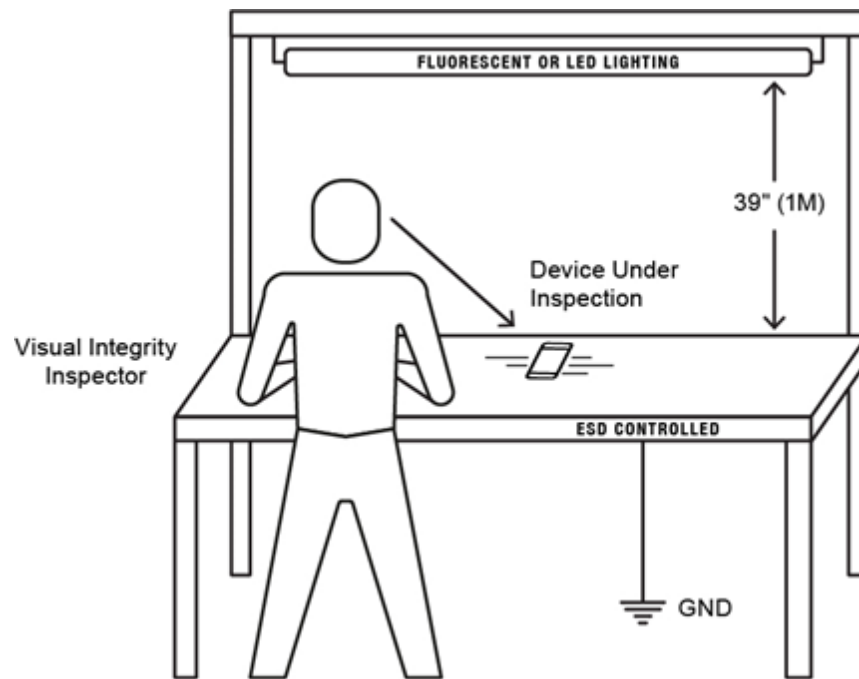

Figure 2.6-1 Viewing and Inspection

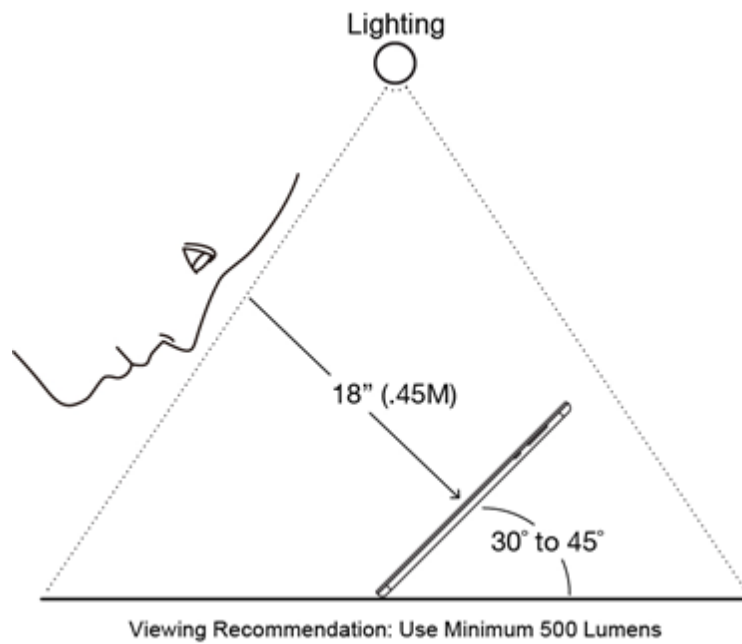
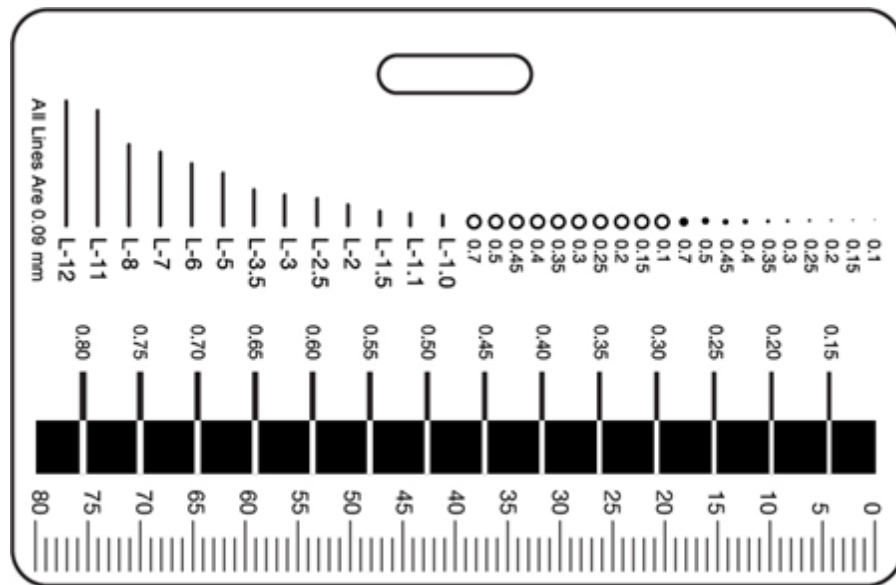

Figure 2.6-2 Lighting



Note: Not to Scale. Representative of a Standard Overlay Measurement Tool.

Figure 2.6-3 Measurement Tool

Figure 2.6-3 is an example of a generic standard measurement tool to be used in evaluating damage marks on devices.

2.7 Cosmetic Surface Area Classification

Table 2.7-1 Cosmetic Grading Scales: Defect by Surface Area Table

Grade	Allowable Cosmetic Defect Levels as Defined in Section 2.6	General Surface Area Descriptions:			
		Surface Area "AA" Main Display & All Camera Lenses	Surface Area "A" Front of Device	Surface Area "B" Back & Side Housing	Survey Area "C" Connectors & Undercovers
Grade A	Level 1 Defect Allow #	0	3	4	N/A
	Level 2 Defect Allow #	0	2	3	N/A
	Level 3 Defect Allow #	0	0	1	N/A
	Automatic Defect Failures* that Downgrade Device to Next Grade	All	All	All	All
Grade B	Level 1 Defect Allow #	5	10	20	N/A
	Level 2 Defect Allow #	2	5	10	N/A
	Level 3 Defect Allow #	2	3	5	N/A
	Automatic Defect Failures* that Downgrade Device to Next Grade	Cover Lens Cracks Camera Lens Cracks Display Damage Display Alignment Pressure Spots Air Bubbles Lifted Lens or Foreign Material Under Lens	Discoloration Gaps Cover Lens Cracks Lifted Lens	Rear Lens Cracks, Cracked Back Surface, Battery Damage, Burr, Discoloration, Warp or Dent, Gaps, Screw Defect, Hinge can't fully close or open, Loose hinge. Excessively noisy hinge	Damage Connector SIM Tray Damage Missing Parts
Grade C	Level 1 Defect Allow #	Unlimited	Unlimited	Unlimited	N/A
	Level 2 Defect Allow #	20	Unlimited	Unlimited	N/A
	Level 3 Defect Allow #	10	20	Unlimited	N/A
	Automatic Defect Failures* that Downgrade Device to Next Grade	Cover Lens Cracks Display Damage Display Alignment Pressure Spots Air Bubbles Lifted Lens or Foreign Material Under Lens	Discoloration Cover Lens Cracks Lifted Lens	Battery Damage Warp	Damage Connector Missing Parts
Grade D	Level 1 Defect Allow #	Unlimited	Unlimited	Unlimited	N/A
	Level 2 Defect Allow #	Unlimited	Unlimited	Unlimited	N/A
	Level 3 Defect Allow #	Unlimited	Unlimited	Unlimited	N/A
	Automatic Defect Failures* that Downgrade Device to Next Grade	Display Damage	Warp	Battery Damage Warp	Damage Connector
Grade E	Level 1 Defect Allow #	Unlimited	Unlimited	Unlimited	N/A
	Level 2 Defect Allow #	Unlimited	Unlimited	Unlimited	N/A
	Level 3 Defect Allow #	Unlimited	Unlimited	Unlimited	N/A
	Defects Included	All	All	All	All

(*) Automatic Defect Failures are any damage measuring greater than Level 3 as defined by DEFECT LEVELS in Table 2-2 and/or the automatic defect failure descriptions identified in this table. Table 2.7 1 Wearable Surface View and Classification

Table 2.7-2 Wearable Surface View and Classification

Grade	Allowable Cosmetic Defect Levels as Defined in Section 2.6	General Surface Area Descriptions:				
		Surface Area "AA" Display	Surface Area "A" Bezel	Surface Area "B" Case, Button, Back	Surface Area "B" Caseback	Survey Area "C" Inner Pin Area
Grade A	Level 1 Defect Allow #	2	3	4	6	10
	Level 2 Defect Allow #	1	2	3	5	8
	Level 3 Defect Allow #	0	0	1	2	3
	Automatic Defect Failures	All	All	All	All	All
Grade B	Level 1 Defect Allow #	5	10	12	20	Unlimited
	Level 2 Defect Allow #	2	5	8	12	Unlimited
	Level 3 Defect Allow #	1	3	4	6	Unlimited
	Automatic Defect Failures	Cover Lens Cracks Display Damage Display Alignment Pressure Spots Air Bubbles Lifted Lens or Foreign Material Under Lens	Burr Dent Discoloration Gaps	Burr Dent Discoloration Gaps Battery Damage	Burr Dent Discoloration Gaps	Damage Pin Hole
Grade C	Level 1 Defect Allow #	Unlimited	Unlimited	Unlimited	Unlimited	Unlimited
	Level 2 Defect Allow #	20	Unlimited	Unlimited	Unlimited	Unlimited
	Level 3 Defect Allow #	10	4	Unlimited	Unlimited	Unlimited
	Automatic Defect Failures	Cover Lens Cracks Display Damage Display Alignment Pressure Spots Air Bubbles Lifted Lens or Foreign Material Under Lens	Burr Dent	Burr Dent Battery Damage	Burr Dent	Damage Pin Hole
Grade D	Level 1 Defect Allow #	All	All	All	All	N/A
	Level 2 Defect Allow #	All	All	All	All	N/A
	Level 3 Defect Allow #	All	All	All	All	N/A
	Automatic Defect Failures	Display Damage	Damage/Missing	Battery Damage	All	Damage Pin Hole
Grade E	Level 1 Defect Allow #	Unlimited	Unlimited	Unlimited	Unlimited	N/A
	Level 2 Defect Allow #	Unlimited	Unlimited	Unlimited	Unlimited	N/A
	Level 3 Defect Allow #	Unlimited	Unlimited	Unlimited	Unlimited	N/A
	Defects Included	All	All	All	All	All

2.8 Functional Classifications

Examples of minor and major common failures as referenced in

Table 2.8-2 above.

Table 2.8-1 General Descriptions of Common Failures

Degree of Failure	Display Failure	Other Failure
Minor	<ul style="list-style-type: none"> Missing pixels but no more than three Burn-in image on bar or menu areas Touch failure for product in which the touch panel is part of the cover lens All external display defects except cracks 	<ul style="list-style-type: none"> Side keys Front camera and flash Proximity and light sensor Speakers or microphones Headset jack Vibrator Finger print sensor if not linked to the main board Battery health Flip sensor
Major	<ul style="list-style-type: none"> Missing pixels, more than three Burn-in image in center area Missing or discolor lines Touch failure for product in which the touch panel is part of the display Dark, white and discoloration spots Backlight brightness 	<ul style="list-style-type: none"> Rear camera Dead battery Finger print sensor if linked to the main board Cannot defect SIM or SD card Does not charge Cannot connect to PC Wi-Fi, Bluetooth, GPS

Table 2.8-2 defines Functional Classification for grading scales criteria as referenced in Table 2.1-1.

Table 2.8-2 Functional Classifications

Type	Power On	Display Failure ¹	Other Failure
0= Fully Functional	Yes	No	No
1	Yes	No	No
2	Yes	Minor	No
3	Yes	Minor	Minor
4	Yes	Minor	Major
5	Yes	Major	Minor
6	Yes	Major	Major
7	Yes	Inoperable	Unverified
8	No	Unverified	Unverified

Type	Power On	Display Failure ¹	Other Failure
9	Not Tested or Functionality Unverified		
Note: For type 0-6, the display was verified to power up.			

Table 2.8-3 Battery Health Thresholds

Type	Battery Health
1	≥ 80%
2	70% - 79%
3	< 70%

Recommended battery health threshold should be equal to or greater than 70% for fully functional classification. For Europe, the recommended battery health threshold should be 80% for fully functional classification [2].

2.9 Lock Status

Table 2.9-1 Customer Lock Status

Type	Cleared Customer Content/Data Wipe	Customer Locked Table 1.3-1
1	Yes	No
2	Yes	Yes
3	No	No
4	No	Yes
5	Unverified	Unverified

[Table 2.9-1](#) further defines Customer Lock Status for grading scales criteria as referenced in [Table 2.1-1](#).

Table 2.9-2 Enterprise and Operator Lock Status

Type	Enterprise Locked	Operator Locked
1	No	No
2	No	Yes
3	Yes	No

4	Yes	Yes
5	Unverified	Unverified

Table 2.9-2 further defines Enterprise and Operator Lock Status for grading scales criteria as referenced in Table 2.1-1.

2.10 RF Grading Scale

Table 2.10-1 RF Test Grading Scale

Type	Test Details
1	No RF test was conducted
2	Passed RF test conducted by making a live call
3	Failed RF test conducted by making a live call
4	Passed RF test conducted using an RF shielded box
5	Failed RF test conducted using an RF shielded box

Table 2.10-1 further defines RF Test Grading Scale for grading scales criteria as referenced in Table 2.1-1.

2.11 Kit Configuration

Table 2.11-1 Kit Configuration

Type	Kit Configuration Details
1	Kitted with OEM charger (block and cord)
2	Fully kitted with OEM charger (block and cord) and headset
3	Kitted with aftermarket charger
4	Fully kitted with aftermarket charger and headset
5	Bulk device, not kitted with any accessories
6	Transceiver only (No battery or back cover if designed to be customer removable parts)

Table 2.11-1 further defines Kit Configuration for grading scales criteria as referenced in Table 2.1-1.

Section 3 Grading Scales Matrix: Cosmetic Grading Scales Cross Reference with Functional Classification

3.1 Cosmetic Grading Scales Cross Reference with Functional Classification

Table 3.1-1 below is a general example of how to create a cosmetic and functional classification matrix. Any combination or cross reference can be utilized to fit multiple business requirements as needed.

Table 3.1-1 Example Grading Scale Matrix

Primary Grade	Cosmetic	Functional	Battery Health	Customer Lock Status	Enterprise and Operator Lock Status	RF Test ¹	Field Usage
A+	A	0 or 1	1 or 2	1	1	2 or 4	0-15 days
A	A	0 or 1	1 or 2	1	1	2 or 4	Any
B+	B	0 or 1	1, 2 or 3	1	1	2 or 4	Any
B	B	0, 1, 2 or 3	1, 2 or 3	1, 2 or 3	1, 2 or 3	1, 2 or 4	Any
C+	C	0 or 1	1, 2 or 3	1	1	2 or 4	Any
C	C	0, 1, 2 or 3	1, 2 or 3	1, 2 or 3	1, 2 or 3	1, 2 or 4	Any
D+	D	0, 1, 2 or 3	1, 2 or 3	1	1	Any	Any
D	D	0, 1, 2, 3 or 4	3	1, 2, 3 or 4	1, 2, 3 or 4	Any	Any
E+	E	0, 1, 2, 3, 4, 5 or 9	3	1, 2, 3 or 4	1, 2, 3 or 4	Any	Any
E	E	Any	3	Any	Any	Any	Any

Note 1: RF not applicable for Wi-Fi only devices.

Any deviations from the grading scale criteria and definitions shall be disclosed to the customer to prevent confusion with the standards defined herein.

Section 4 Simplified Cosmetic Grading Classification for Wearables

Table 3.1-1 below is an *example* of how to create a simplified version of cosmetic grading only for wearables. Any combination or cross reference can be utilized to fit multiple business requirements as needed.

Table 3.1-1 Example Wearable Simplified Cosmetic Grading

Surface => Grade	Display	Bezel	Case	Caseback	Band
A	≤ 2 L1 defects ≤ 1 L2 defects	≤ 3 L1 defects ≤ 2 L2 defects	≤ 4 L1 defects ≤ 3 L2 defects ≤ 1 L3 defects	≤ 6 L1 defects ≤ 5 L2 defects ≤ 2 L3 defects	Like new inbox condition
B	≤ 5 L1 defects ≤ 2 L2 defects ≤ 1 L3 defects	≤ 10 L1 defects ≤ 5 L2 defects ≤ 3 L3 defects	≤ 12 L1 defects ≤ 8 L2 defects ≤ 4 L3 defects	≤ 20 L1 defects ≤ 12 L2 defects ≤ 6 L3 defects	Refurbish or recondition
C	Unlimited L1 defects ≤ 20 L2 defects ≤ 10 L3 defects	Unlimited L1 & L2 defects ≤ 4 L3 defects Dent, Discoloration, Gaps	Unlimited L1, L2 & L3 defects Dent, Discoloration, Gaps	Unlimited L1, L2 & L3 defects Dent, Discoloration, Gaps	N/A

Appendix A Revision History

Date	Version	Description
December 2018	1.0	Initial release of document
December 2019	1.1	<ul style="list-style-type: none"> • Revised Figure 2-2: Top to Bottom Side View • Added introduction to Section 2.3: Surface Area Definitions • Added Pressure Spot definition to Section 2.4: Defect Definitions Surface • Revised Figure 2-12: Battery Contacts for Customer Removable Battery • Added note to Table 2-2: Defect Levels • Revised Table 2-4: Cosmetic Grading Scales: Defect By Surface Area Table
September 2021	2.0	<ul style="list-style-type: none"> • Updated Table 1.3 1 Definitions to include “operator lock” and “enterprise lock” • Updated figure titles in Section 2 • Added illustrations of defined tablet surface areas to Section 2 • Streamlined Table 2.8 1 Functional Classifications definitions • Split lock status tables into Table 2.9 1 and Table 2.9 2 • Added “Enterprise Lock” column in Table 2.9 2 • Streamlined functional classifications in Table 3.1 1 Example Grading Scale Matrix and added in Enterprise Lock detail • Added footnotes to Table 3.1 1
September 2023	3.0	<ul style="list-style-type: none"> • Expanded the definition of “devices” in scope to include wearables and fitness trackers. • Added figure of “AA” Surface Example for Wearables • Added figure of “A” Surface Example for Wearables • Added figure of “B” Surface Example for Wearables • Added figure of “C” Surface Example for Wearables • Added table 2.7 2 Wearable Surface View and Classification • Added Section 4 Simplified Cosmetic Grading Classification for Wearables • Added recommended battery health threshold for Europe based on regulation released by the European Commission